

This decal can be used with the Airfix or Matchbox kits of the Buccaneer S2.

RAF Buccaneers have always worn a standard Dark Green and Dark Sea Grey camouflage on the upper surfaces. In the early days the undersurfaces were in Light Aircraft Grey, but by the mid-seventies this had been changed to the now familiar wrap-around scheme. The presentation of the tail codes has also changed from single letters to two letters and the last three of the serial and it should be noted that the position of the fin flash has depended on the style of these codes. The aircraft on this decal have been chosen to represent these various changes. XW529 still retained the original camouflage with light aircraft grey undersurfaces in 1988 and is used by B.Ae for test purposes at Brough. 12 Squadron is well known for its Foxes Head badge and in the early 80s each aircraft carried a variation on this theme and four of these variations are included as well as the now standard Head on XT273. And on two of these aircraft the details even varied from one side and the other (XV361, XN983). XX900 was repainted in a desert camouflage when it took part in a Red Flag exercise in 1977 but note that the rear fuselage and air brake were left in green and grey. 208 Squadron have made little change to their badge over the years, but whereas it was previously on a white disc it was later placed straight onto the intake and codes were changed from two letters to a single letter. 216 Squadron enjoyed a fairly short life and was disbanded after only a few months in 1979. XW988 was painted in the garish dark green, yellow and white scheme for Test purposes by the Royal Aircraft Establishment at Farnborough.

PAINTING. A better finish will result and the decals will have a "Painted on" look if they are applied to a gloss paint surface, with a final matt, satin or gloss varnish coat to provide the correct final effect. The Micro/Superscale Decal system may be used with these decals.

XTRACOLOR Authentic Paints have a "Decal ready" gloss finish and all the colours needed for these Buccaneers are available. X1 Dark Green. X2 Dark Earth. X29 Light Stone. X4 Dark Sea Grey. X15 Light Aircraft Grey. X19 Rescue Yellow. X141 White. X502 Natural Steel. X503 Oily Steel. X504 Exhaust. X505 Tyre Black.

Research by Ashley Annis with additional material from Richard Barker, Roger Smith, Don Myhill and Fl. Lt. Paul Levick 12 Sqn. Produced by H. G. Hannant Ltd., Trafalgar House, 29-31 Trafalgar Street., Lowestoft, Suffolk NR32 2AT, England. Tel: 01502 517444



BUCCANEER S2

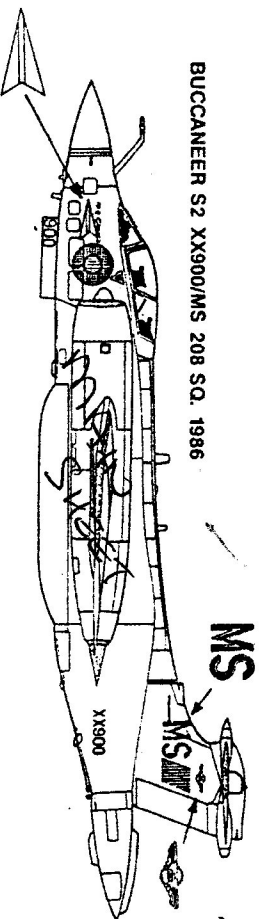

BUCCANEER S2 XX900/MS 208 SQ. 1986

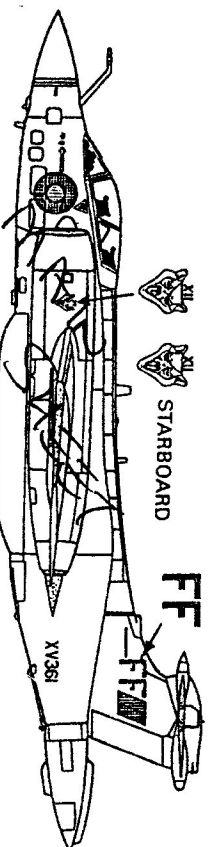

BUCCANEER S2 XV361/FF 12 SQ. 1985

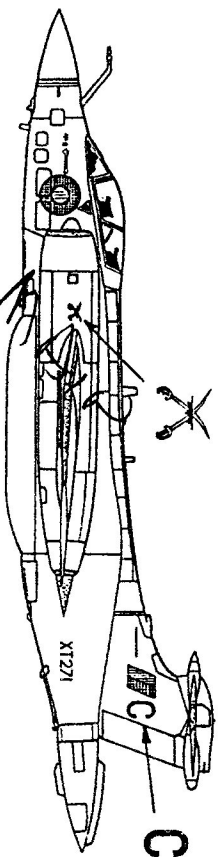

BUCCANEER S2 XT271/C 237 OCU 1982

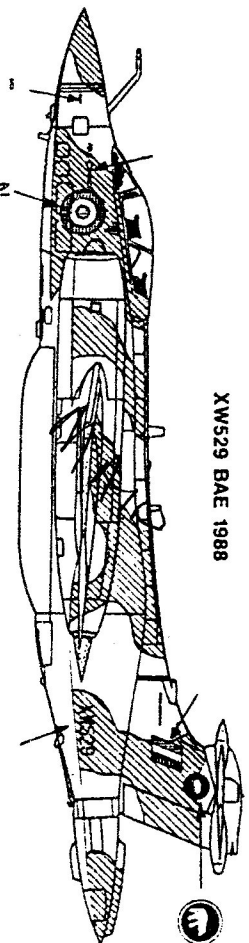

XW529 BAE 1988

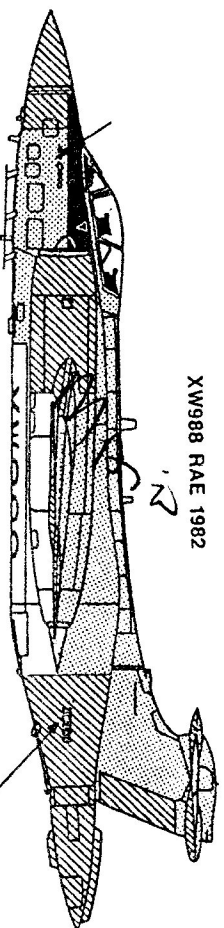

XW988 RAE 1982

BUCCANEER S2

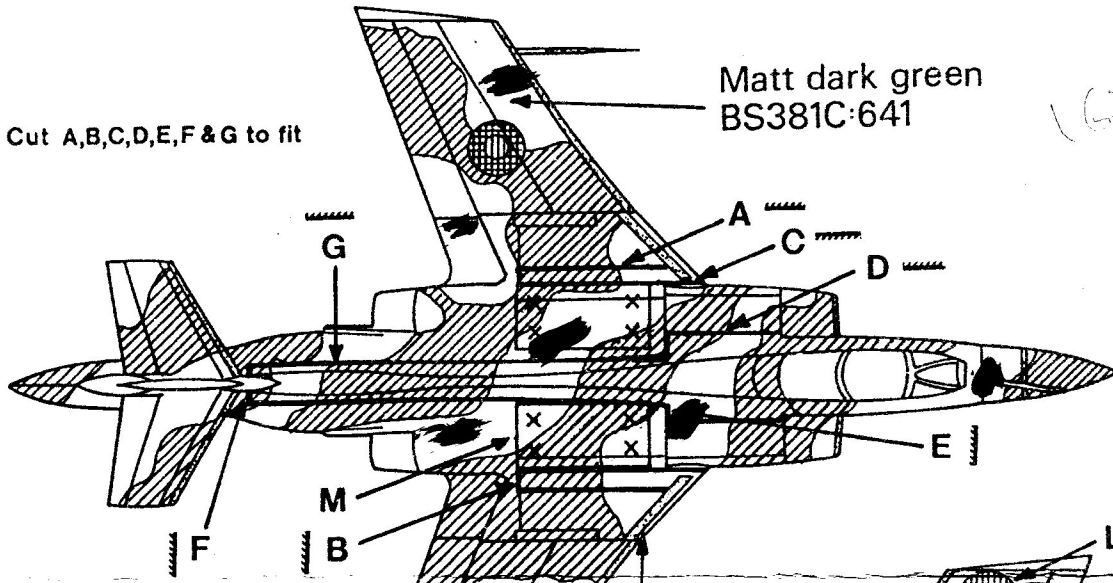
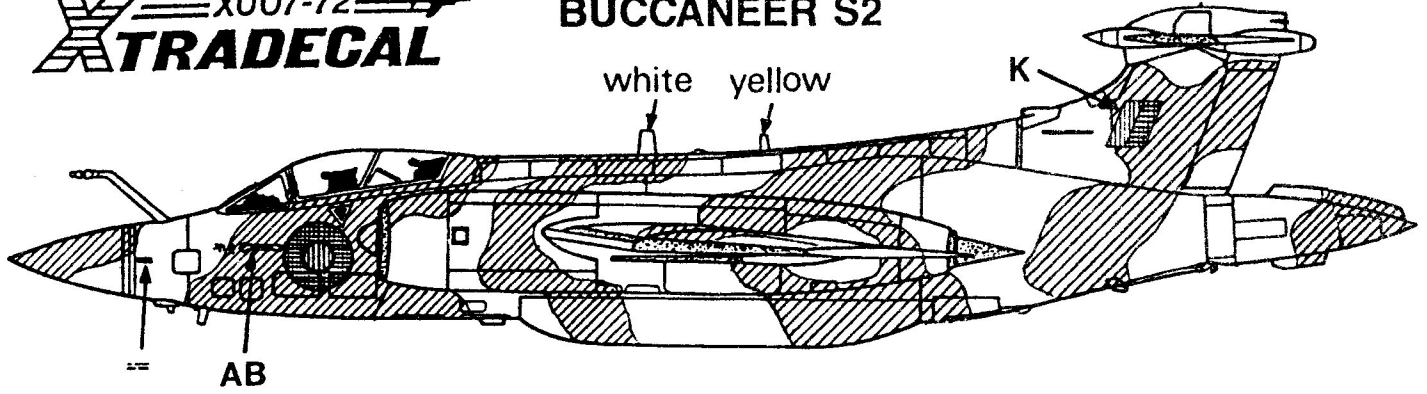

'H' & 'M' can vary
 check references

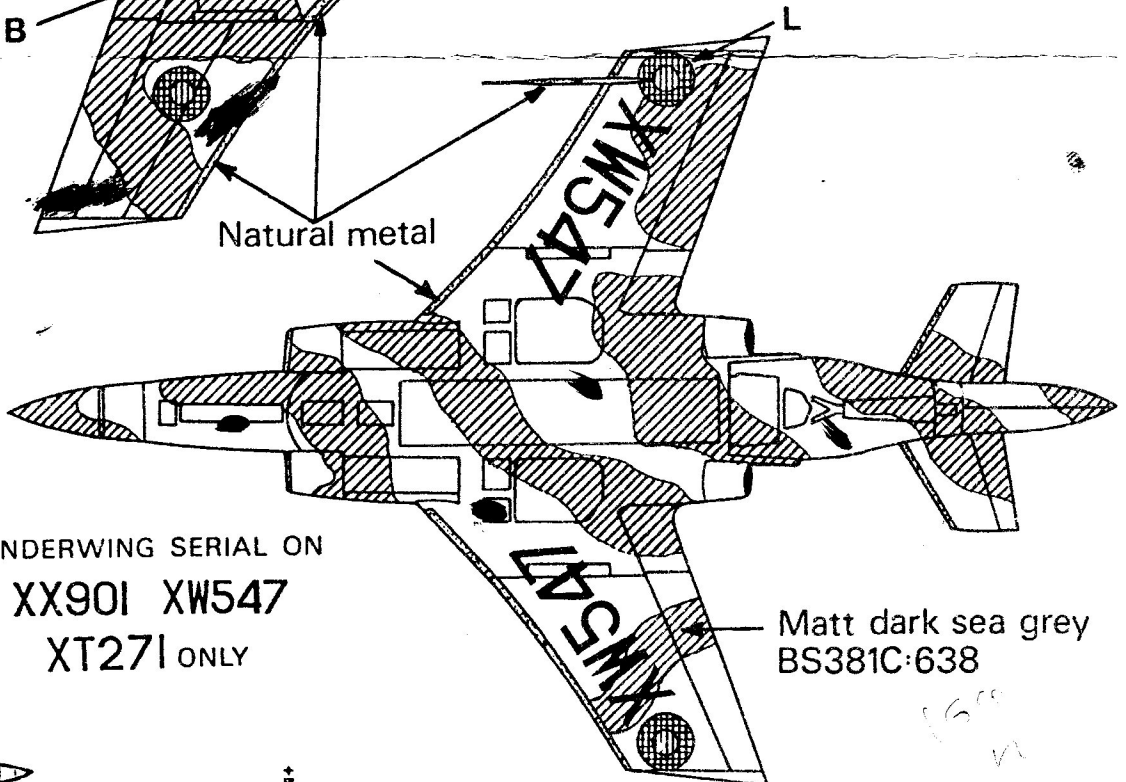

UNDERWING SERIAL ON
 XX901 XW547
 XT271 ONLY

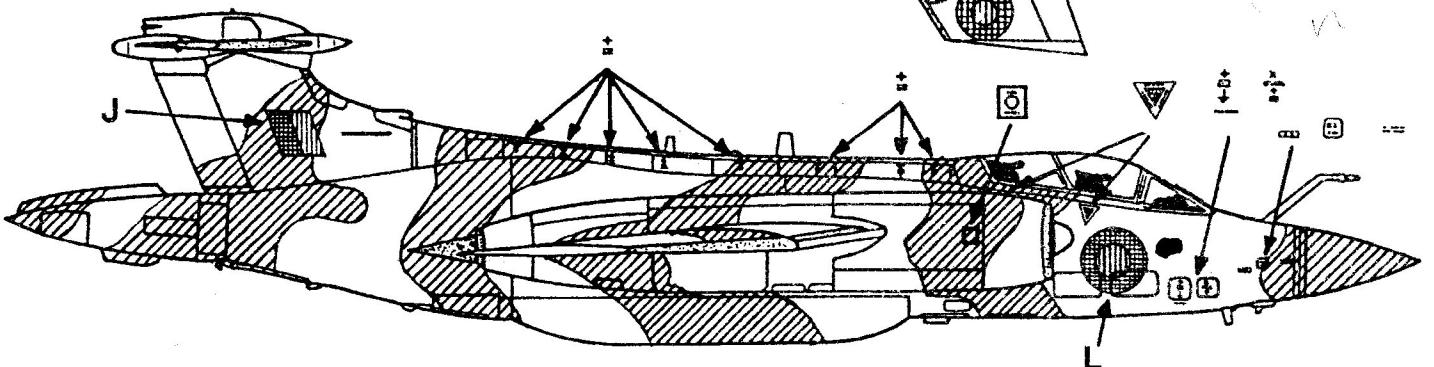

BUCCANEER S2

BUCCANEER S2 XX900/MS 208 SQ. 1986

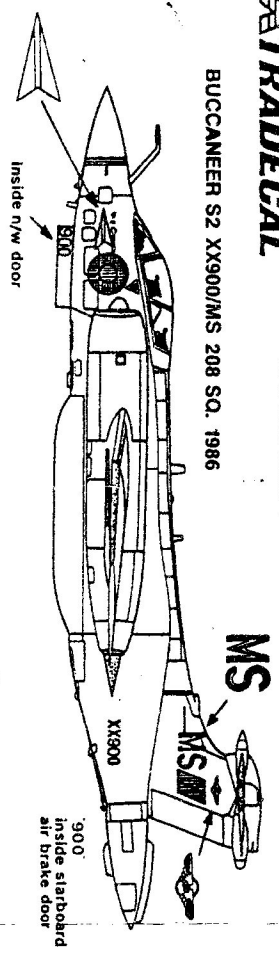

BUCCANEER S2 XV355/AC 237 OCU 1984

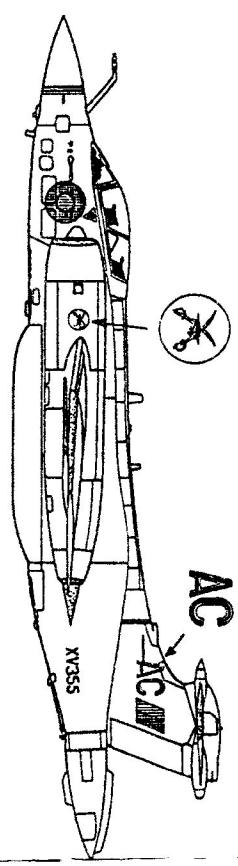

BUCCANEER S2 XV355/I 237 OCU 1988

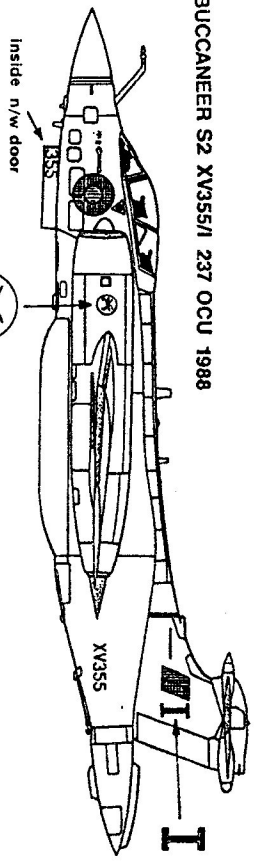

BUCCANEER S2 XT721/C 237 OCU 1982

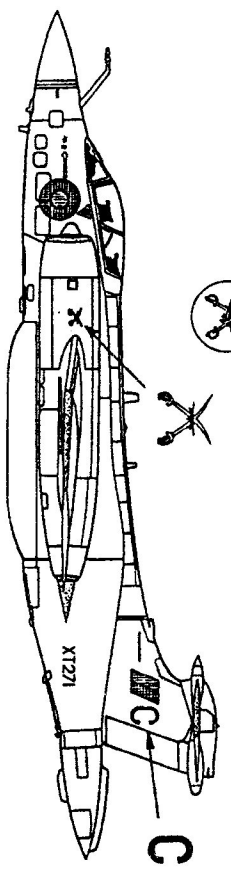

BUCCANEER S2 XW547 216 SQ. 1979

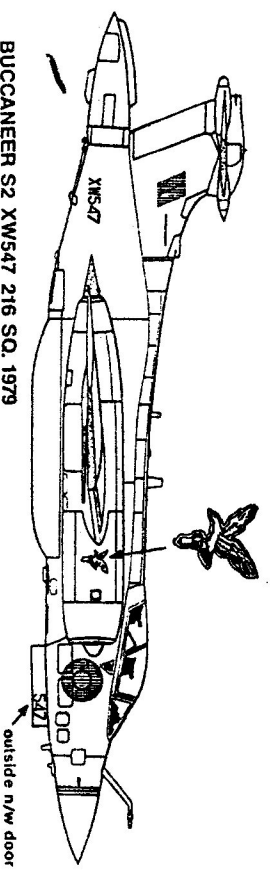

BUCCANEER S2 XV361/FF 12 SQ. 1985

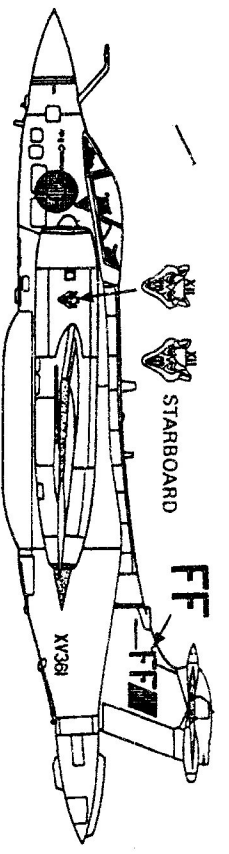

BUCCANEER S2 XX885/OF 12 SQ. 1984

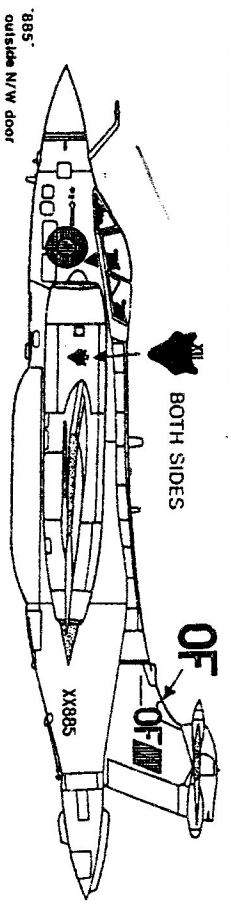

BUCCANEER S2 XN983/PF 12 SQ. 1985

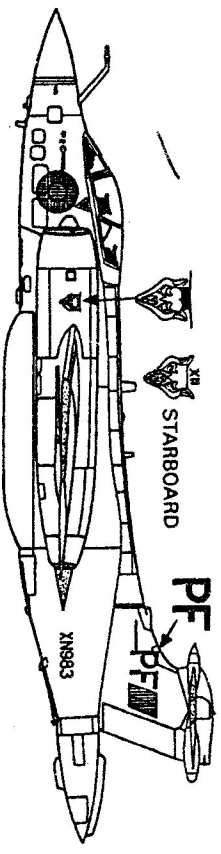

BUCCANEER S2 XV165 12 SQ. 1988

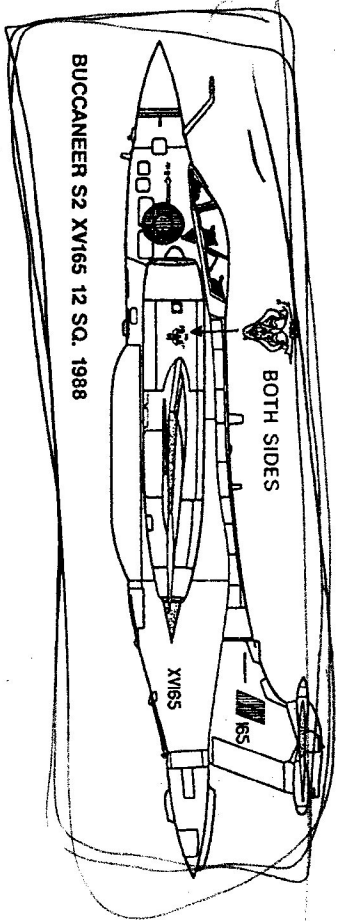

BUCCANEER S2 XT723 12 SON 1988

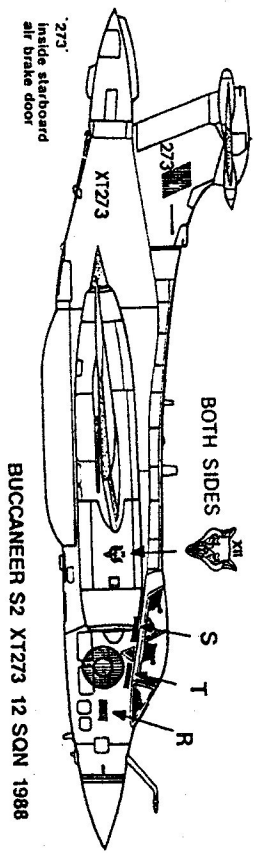

X007-72
TRADICAL

BUCCANEER S2
 XW529 BAE 1988

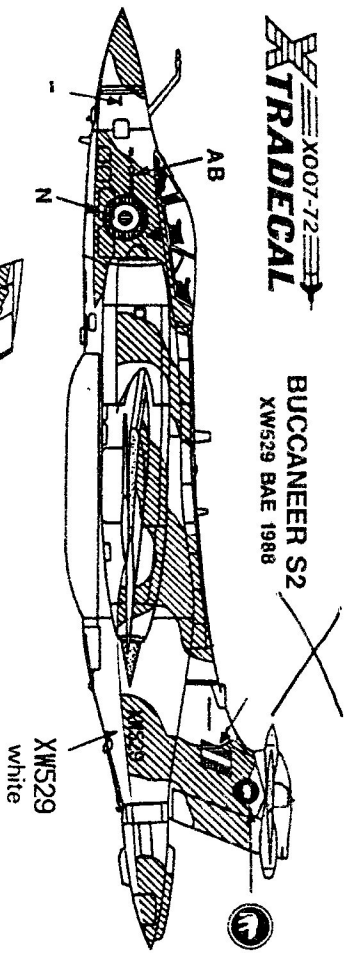

Gloss dark sea grey
 BS381C:638

Natural metal

Cut A,B,C,D,E,F,G to III

H&M can vary
 check references
 Gloss dark green
 BS381C:641

Undersides
 Gloss light aircraft grey
 BS381C:627

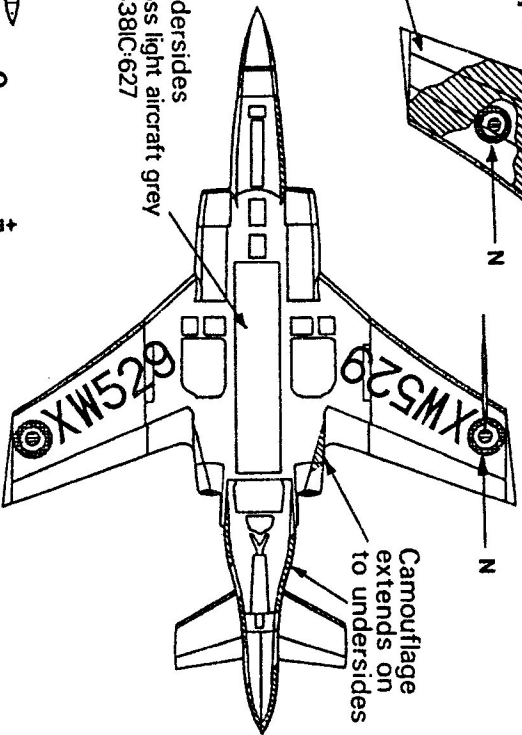

Camouflage
 extends on
 to undersides

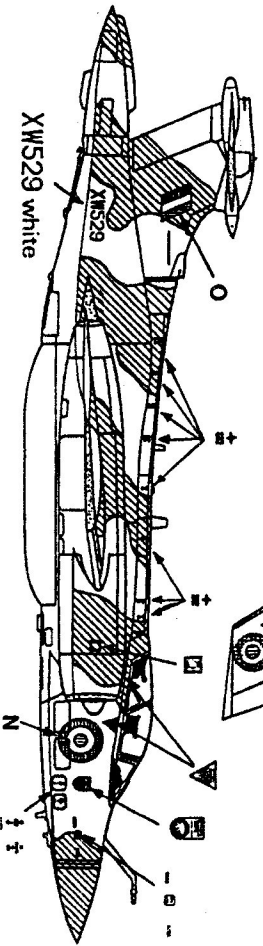

BUCCANEER S2
 XW988 RAE 1982

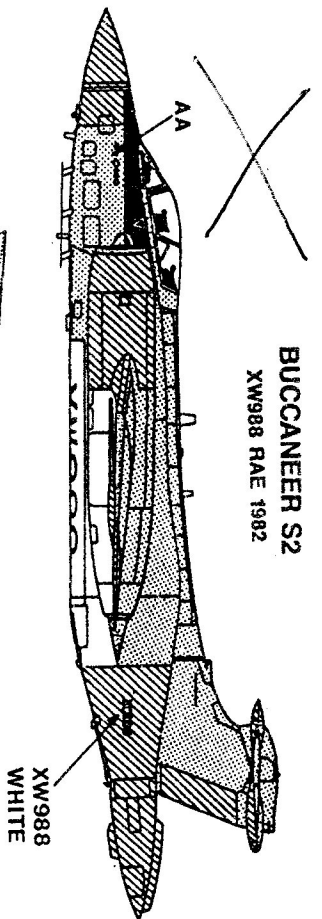

Natural metal

Matt black

Gloss yellow

BUCCANEER S2 XX901 208 SQ. 1977
 RED FLAG 77-9

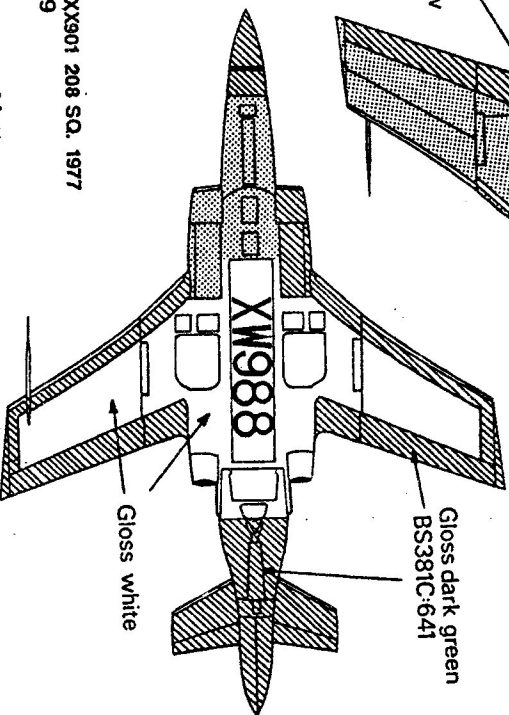

Gloss dark green
 BS381C:641

Gloss white

Matt
 Light stone
 BS381C:361

Matt
 Dark earth
 BS381C:450

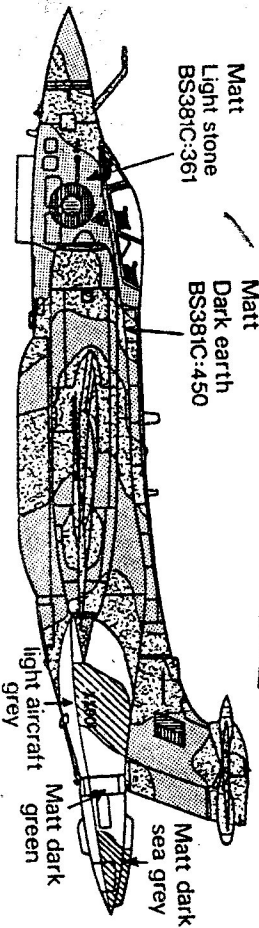

X007-72
TRADECAL

BUCCANEER S2

AA
RESCUE

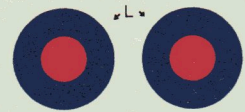
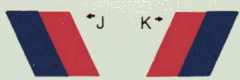
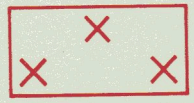
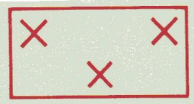
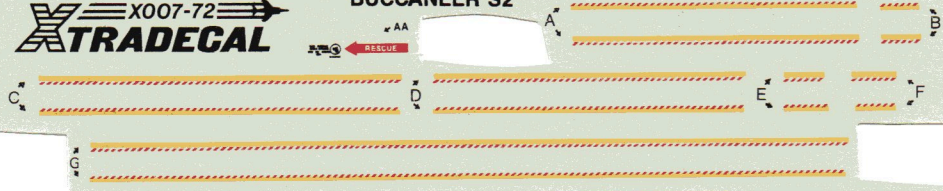

XW547 XW547

XW547

900 XX900 XX900

XV355  

XW547

MS MS

XV355
355  

273 XT273 XT273

II AC AC  

CC

FF FF

XT271 XT271

XV361  

XT271 XT271

PF PF OF OF



XN983   XX885
XX885



983 XW988
XN983

XW529

XX901

XW529



XX901
XX901

XX901