



P-51D interior late ser.20-35 S.A.



33 103

1/32 scale detail set for Tamiya kit • sada detailů pro model Tamiya 1/32

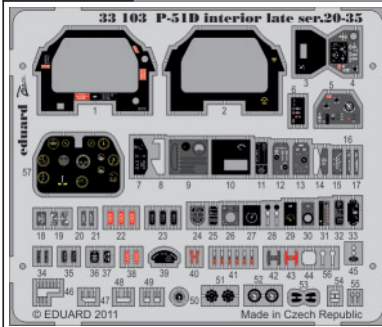

- SYMMETRICKÁ ASSEMBLY / SYMETRICKÁ MONTÁŽ
- REMOVE / ODSTRANIT
- BEND / OHNOUT
- REPLACE / NAHRADIT
- GRIND / OBRUSIT
- OPTION / VOLBA

ORIGINAL KIT PARTS / PŮVODNÍ DÍLY STAVEBNICE

PHOTO-ETCHED PARTS / LEPTANÉ DÍLY

PARTS TO BE REMOVED / DÍLY K ODSTRANĚNÍ

FILL / TMELIT

The main assembly diagrams are organized into several panels:

- Top Left:** Shows the installation of the main instrument panel (D31) into the fuselage (part 1). It includes photo-etched parts 2, 34, 40, 42, 43, 44, 45, 49, and 57. A red area on D31 indicates parts to be removed. A legend shows a red square with a diagonal line equals a hatched square. Part 41 is shown in two pieces.
- Top Right:** Shows the installation of a small component (D15) with a blue ring (50).
- Middle Right:** Shows the battery (D43) being installed with photo-etched parts 22 and 23.
- Middle Left:** Shows the installation of a control panel (D48) with parts 3, 4, 5, 41 (3 pcs), and 48.
- Center:** Shows the installation of a base component (D23) with parts 19, 52, and 52.
- Middle Right (Lower):** Shows the installation of a control panel (D5) with parts 33, 53, 54, and 55.
- Bottom Left:** Shows the installation of a control panel (D17) with parts 9, 10, 14, 16, 17, 20, and 21.
- Bottom Center:** Shows the installation of a control panel (D1) with parts 12, 13, and 49.
- Bottom Right (Upper):** Shows the installation of a control panel (D6, D13) with part 39.
- Bottom Right (Lower):** Shows the installation of a control panel (D11) with parts 31, 35, and 38.

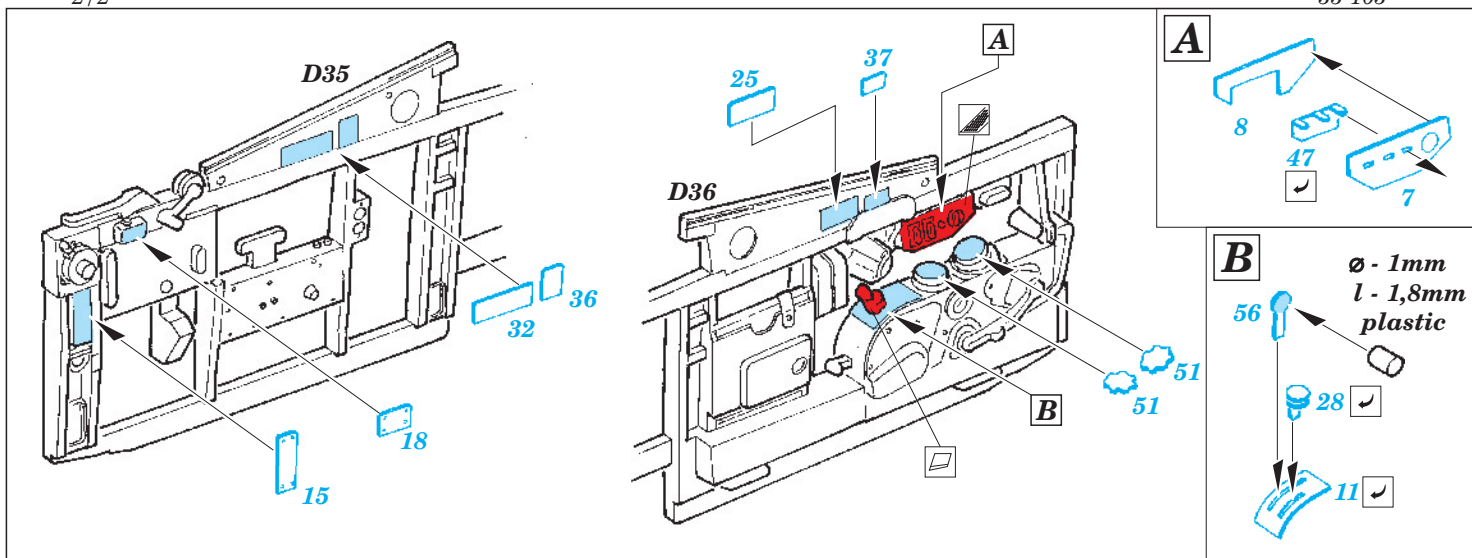

*For further detail sets look for **eduard** 32 731 P-51 seatbelts
(not included in this set)*

*For further detail sets look for **eduard** 32 302 P-51D exterior
(not included in this set)*

*For further detail sets look for **eduard** 32 307 P-51D engine
(not included in this set)*

*For further detail sets look for **eduard** 32 721 P-51D gun bay late
(not included in this set)*

PARTS WITH GLUE • DÍLY OPATŘENÉ LEPIDLEM

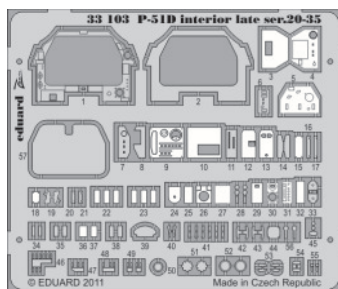

3. Do not touch the adhesive areas of the etched components.
3. Nesahejte na části dílů, na kterých je naneseno lepidlo.

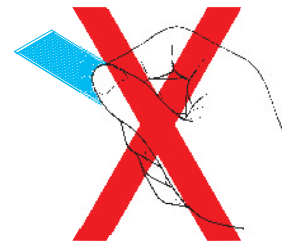

1. Separate the etched components from their frames on the protective paper. Removal from the paper is done only after separation of the parts from the frames.
1. Samolepicí díly oddělujte od rámečku na podkladovém papíře. Po oddělení je sejměte z krycího papíru.

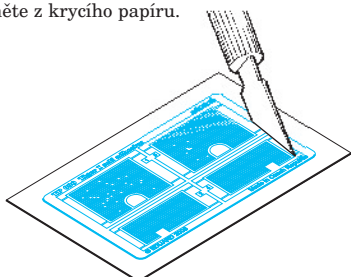

2. Do not inadvertently place etched components on an unwanted surface. Attempts to remove will result in damage to your part.
2. Nepokládejte samolepicí díly na volné plochy. Pokud je omylem přilepíte, při pokusu o odlepení dojde k poškození dílu.

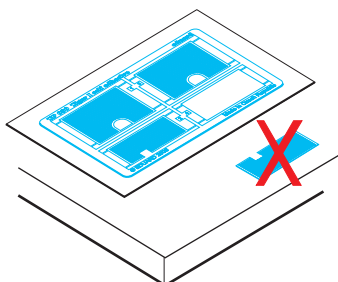

4. Hold the parts by the edges, or at areas free of adhesive.
4. Samolepicí díly berte za hrany nebo za části, na kterých není nanesené lepidlo.

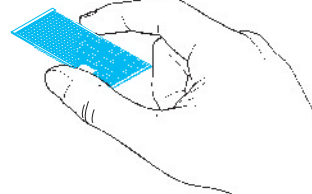

5. Lightly place the component in the desired location and position. Adjust as required. The component will be permanently affixed when pressed onto its intended location, its location can be adjusted.
5. Díl lehce položte do pozice, ve které má být nalepen. Upravte přesnou pozici a přimáčkněte. Díl dokonale přilne až po přimáčknutí, před přimáčknutím lze dílem opatrně manipulovat.

