

RONIN DECALS

LIMITED EDITION DECALS

Copyright 2023©

<https://roningraphicsaustralia.com>

www.facebook.com/Ronin-Graphics-Australia



RAAF "City of Hobart" MIRAGE IIIO & ARDU MIRAGE IIIO/D HISTORY



The RAAF Roundel, Squadron markings and badges have been reproduced under license and with the permission and approval of the Royal Australian Air Force.

1/48

RDS-083

Choice of 18 different schemes

NEW ARTWORK + EXTRA NEW SCHEMES

COMPLETE WITH ALL DATA AND ENOUGH TO BUILD 3 AIRCRAFT

Fully Screen Printed

Designed and Printed by Ronin Graphics Australia



Produced by
Ronin Graphics Australia

*This Booklet and decal set is copyright to Ronin Graphics Australia
No part of this booklet or decal set may be reproduced by any process
with out written permission from Ronin Graphics Australia*



*The RAAF Roundel, Squadron markings and badges have
been reproduced under license and with the permission
and approval of the Royal Australian Air Force.*

INSTRUCTIONS: Applying the decals.

1. Water solution for decal. Add a drop of dishwashing soap to a tray of warm water
2. We recommended that you cut as close to the item as possible to achieve the best results from each decal.
3. When soaking in water, you will need to soak them until the decal has come loose from the paper or until you can gently move it around on the paper with your finger. Alternatively you can leave it in the water until it starts to lift.
4. Wet area on the model first before applying decal as this will help you position the decal in the correct place.
5. Then slide the item off the paper and straight on to the model, using your fingers.
6. Once on the model and in the right position, lightly press down on it with a dry tissue to soak up the excess water.
7. Once the decal has set and is dry you may then use some decal setting solution to help the decal adhere to the paint on the model.

Warning: Be very gentle with the decal film when applying to the model. As the decal film is very thin and may tear if mistreated.

Colour Reference Chart/Guide

 A BS-538c Post Office Red	Model Master	MM:1705	 B Matt Black K3/179 FS-37038	Model Master	MM:1583	 C Flat Black	Model Master	MM:1749
	Humbrol	H:19		Humbrol	H:33		Humbrol	H:85
	Gunze	H:3		Gunze	H:12		Gunze	H:137
	Xtra Colour	X:031		Xtra Colour	X:92		Xtra Colour	X:505
 D BS-105c Oxford Blue	Model Master	MM:1719	MATT / HIGH GLOSS  E BS-298c Olive Drab	Model Master	MM:1711	 F Dark Ghost Grey FS-36320	Model Master	MM:1741
	Humbrol	H:104		Humbrol	H:66		Humbrol	H:128
	Gunze			Gunze	H:78		Gunze	H:307
	Xtra Colour	X:023		Xtra Colour	X:111		Xtra Colour	
 H BS-224c Deep Bronze Green	Model Master	MM:34079	MATT / HIGH GLOSS  I BS-640c Extra Dark Sea Grey	Model Master	MM:2059	 J Burnt Metal	Model Master	MM:1424
	Humbrol	H:3 95% H:21 5%		Humbrol	H:123		Humbrol	
	Gunze			Gunze	H:333		Gunze	
	Xtra Colour			Xtra Colour	X:005		Xtra Colour	
 K BS-356 Golden Yellow	Model Master	MM:1707	 L Fluro Orange	Model Master	MM:1708 50% MM:2041 50%	Ultra Gloss/ Gloss  M BS-557 Orange	Model Master	MM:1127
	Humbrol	H154		Humbrol	H:69 50% H:209 50%		Humbrol	H:18
	Gunze	H329		Gunze	H:4 50% H:98 50%		Gunze	H:58
	Xtra Colour	X:109		Xtra Colour			Xtra Colour	
 N Silver (Undercarriage legs)	Model Master	MM:1418	 O BS-627 Light Grey	Model Master	MM:1728 60% MM:1745 40%	 P Gloss White	Model Master	MM:1745
	Humbrol	H11		Humbrol	H:166		Humbrol	H:22
	Gunze	H8		Gunze	H:332		Gunze	H:1
	Xtra Colour	X:142		Xtra Colour	X:15		Xtra Colour	X:2
UNDERSIDE  Q Light Gull Grey FS-36440	Model Master	MM:1708	 R Steel	Model Master	MM:1420	TACAN Antenna  U BS-353 Deep Cream	Model Master	MM:2709
	Humbrol	H:129		Humbrol	H:27003		Humbrol	H:41
	Gunze	H:11		Gunze			Gunze	
	Xtra Colour	X:137		Xtra Colour			Xtra Colour	
FIN CAP SILVER  T Light Grey FS-16492	Model Master	MM:2038		Model Master			Model Master	
	Humbrol			Humbrol			Humbrol	
	Gunze			Gunze			Gunze	
	Xtra Colour			Xtra Colour			Xtra Colour	



Scheme 1.

A3-2 1968 Lizard Scheme

A3-2. Avalon, Vic, March 1968, wearing the new Lizard scheme.
A3-2 served most of its life with ARDU. This was just one of many paint schemes that this aircraft would adorn in its service life with the RAAF.

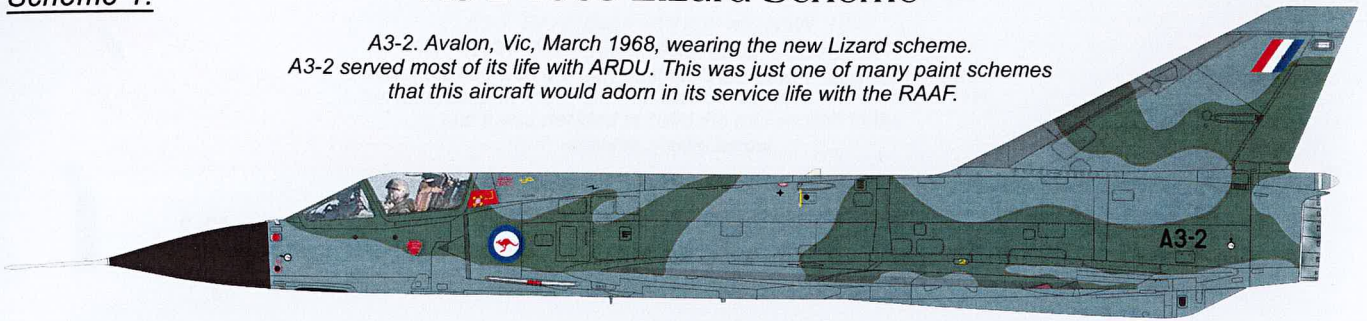

Marking Note:

This aircraft scheme didn't carry any rescue arrows.
The rescue break glass panels are in red with large ejection seat triangles.
The static connection symbol is in red instead of usual yellow.
All leading edges are coated with a high gloss clear.
See data placement sheet.

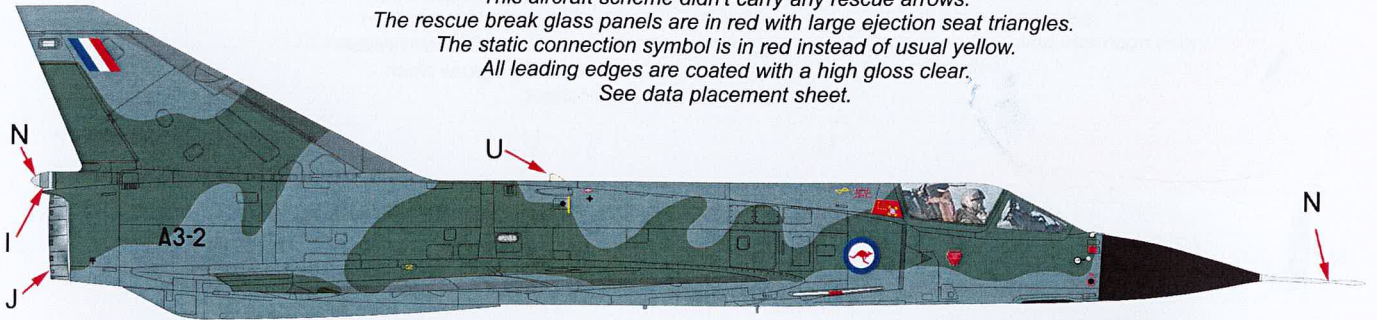

A	B	E	I	J	N
BS-538c Post Office Red	Matt Black K3/179 FS-37038	MATT / HIGH GLOSS BS-298c Olive Drab	MATT / HIGH GLOSS BS-640c Extra Dark Sea Grey	Burnt Metal	Silver
TACAN Antenna					
	U				
BS-353 Deep Cream					

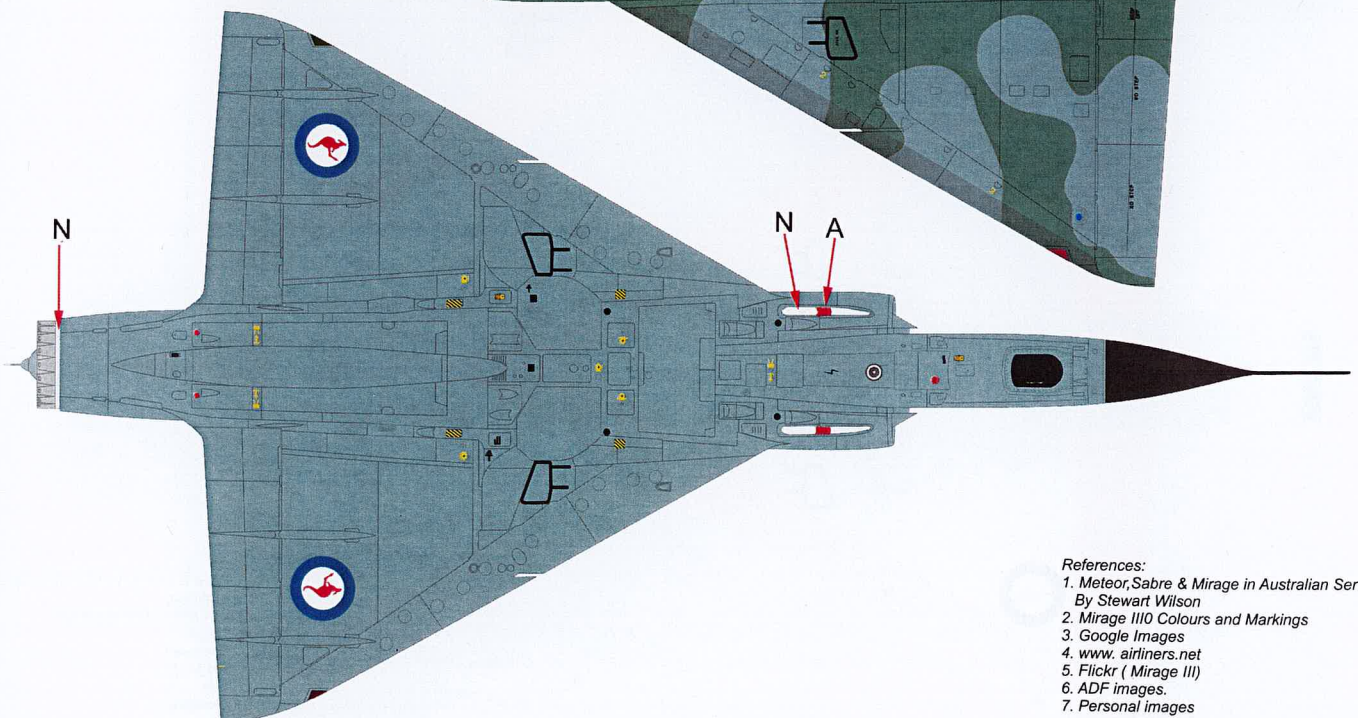
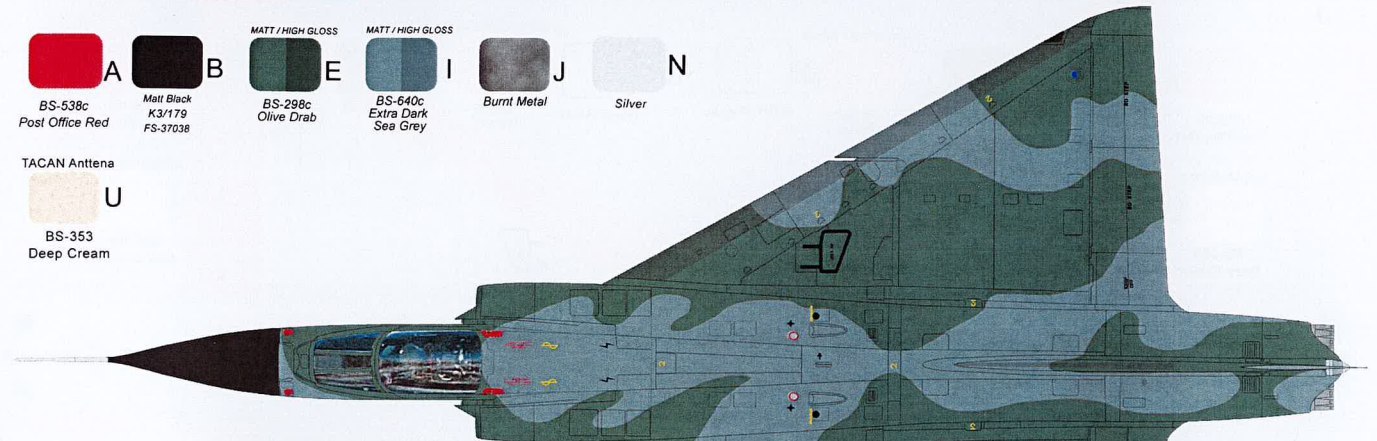

- References:
1. Meteor, Sabre & Mirage in Australian Service By Stewart Wilson
 2. Mirage III Colours and Markings
 3. Google Images
 4. www. airliners.net
 5. Flickr (Mirage III)
 6. ADF images.
 7. Personal images



Scheme 2.

A3-2 1983 "Fanta Can" Scheme



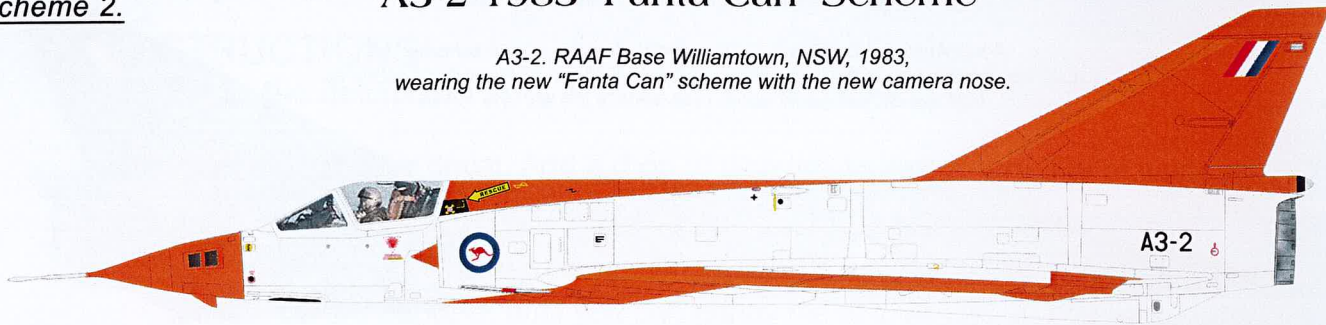



A3-2. RAAF Base Williamtown, NSW, 1983,
wearing the new "Fanta Can" scheme with the new camera nose.

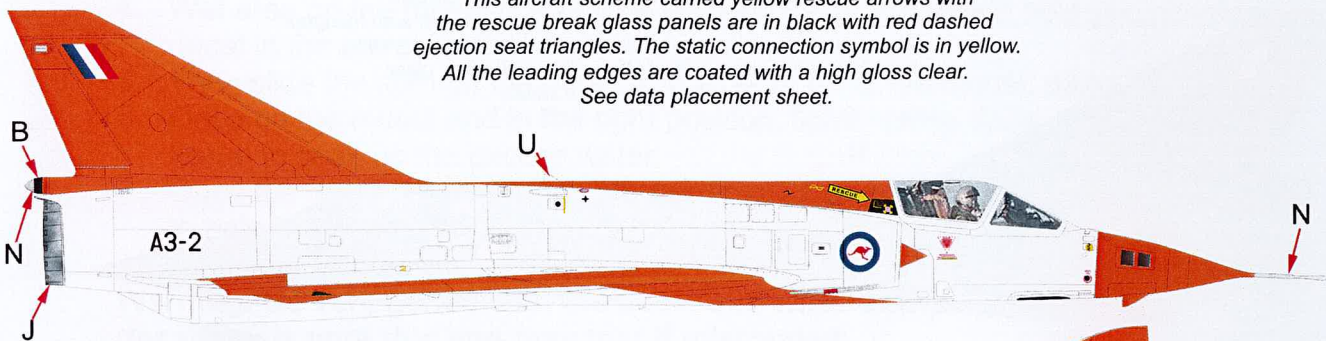

Marking Note:

This aircraft scheme carried yellow rescue arrows with the rescue break glass panels are in black with red dashed ejection seat triangles. The static connection symbol is in yellow. All the leading edges are coated with a high gloss clear. See data placement sheet.



 A	 B	 J	 M	 N	 P
BS-538c Post Office Red	Matt Black K3/179 FS-37038	Burnt Metal	BS-557 Orange	Silver	Gloss White
TACAN Antenna					
 U					
BS-353 Deep Cream					

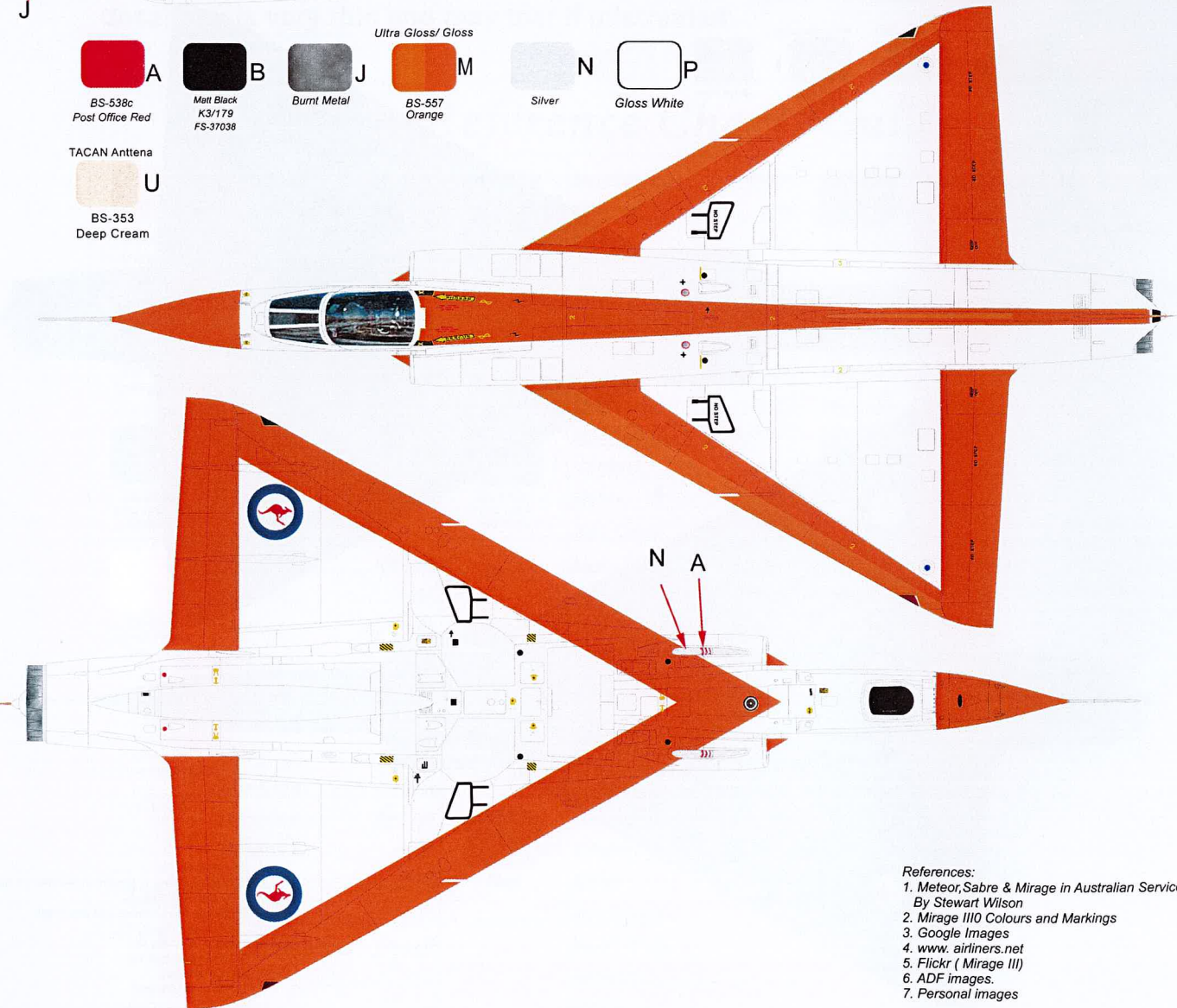

- References:
1. Meteor, Sabre & Mirage in Australian Service
By Stewart Wilson
 2. Mirage III Colours and Markings
 3. Google Images
 4. www.airliners.net
 5. Flickr (Mirage III)
 6. ADF images.
 7. Personal images



Scheme 3.

A3-2 1985 "Fanta Can" II Scheme

A3-2. RAAF Base Williamtown, NSW, 1983, wearing the new "Fanta Can" scheme with the new camera nose. The first "Fanta Can" scheme was very successful in its high visibility, but unfortunately the white mid section started show wear and tear and it was decided to paint the mid section to the scheme shown below.

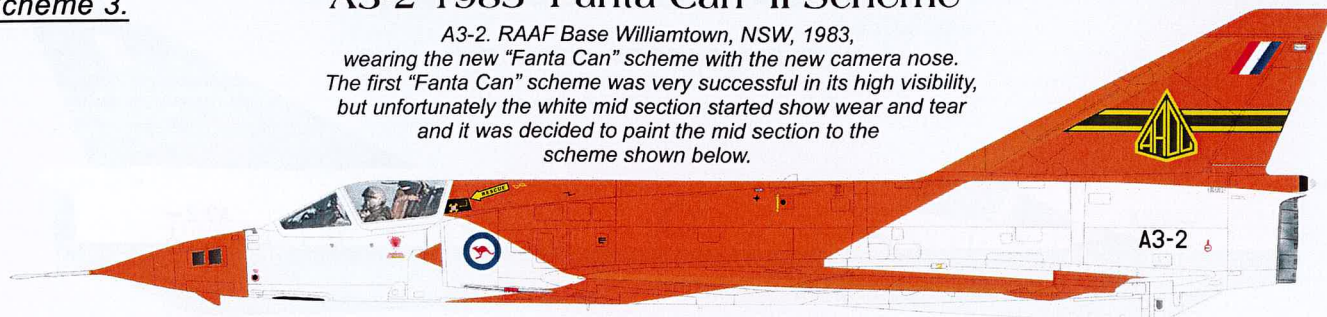

Marking Note:

On this version of the "Fanta Can" scheme the ARDU tail flash was added. This version didn't carry the static connection symbol on the nose or on front undercarriage door. All the leading edges are coated with a high gloss clear. See data placement sheet.

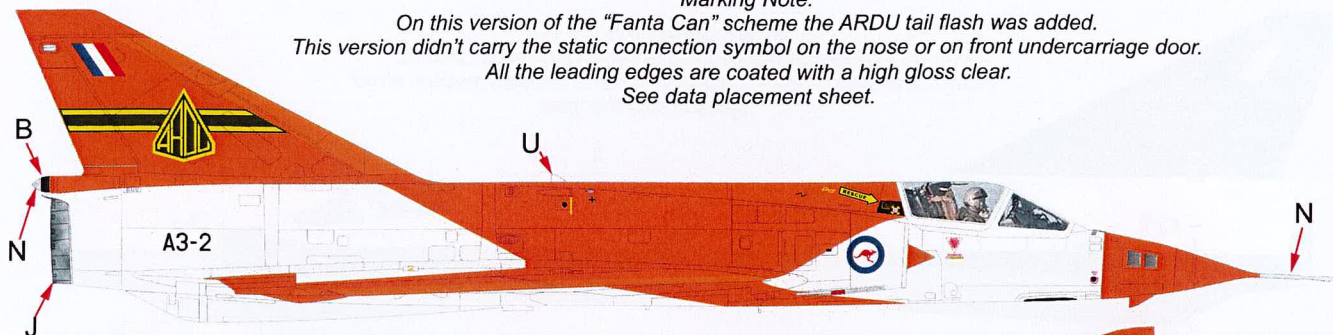

A	B	J	M	N	P
BS-538c Post Office Red	Matt Black K3/179 FS-37038	Burnt Metal	Ultra Gloss/ Gloss BS-557 Orange	Silver	Gloss White
TACAN Antenna					
	U				
BS-353 Deep Cream					

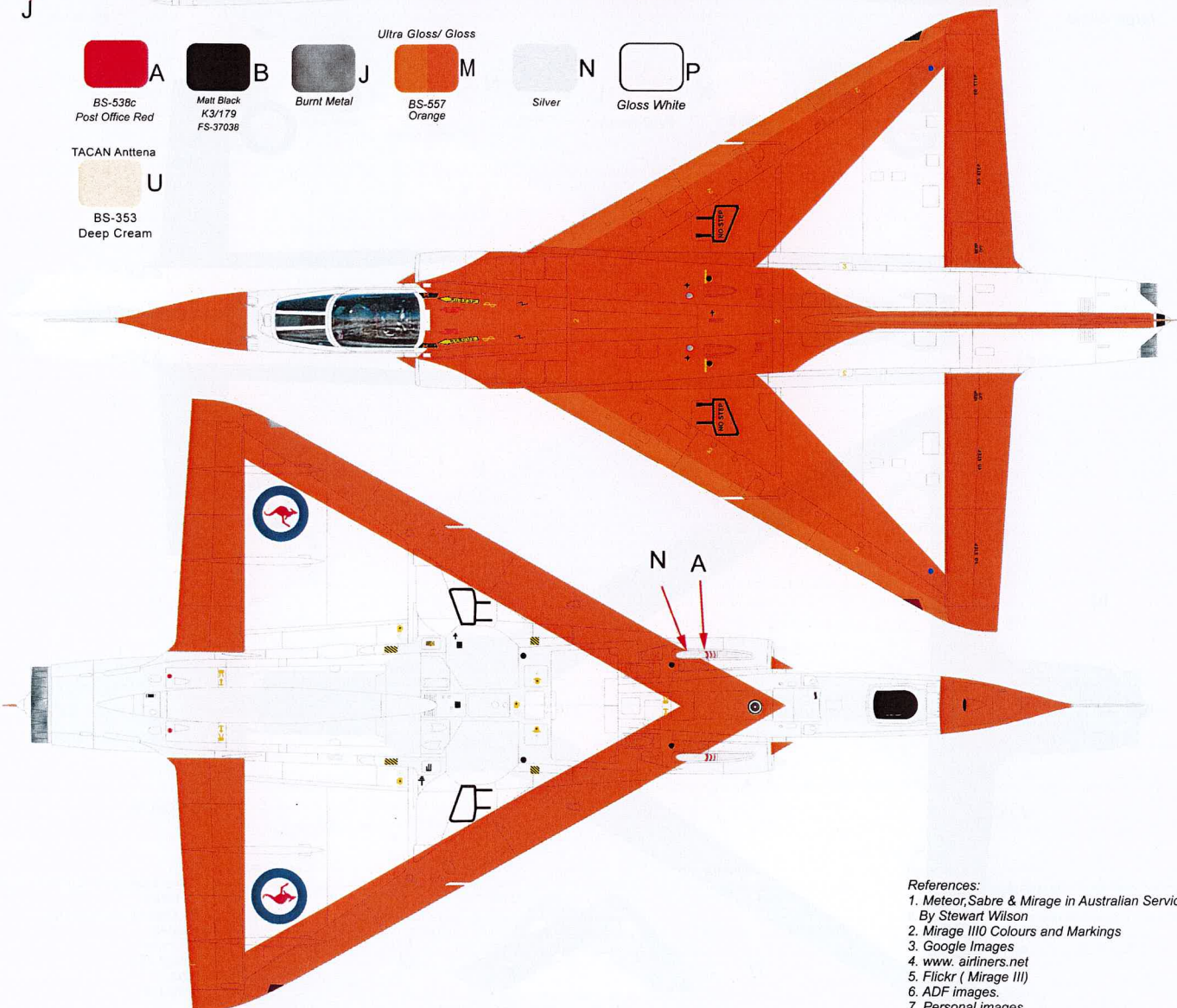

- References:
1. Meteor, Sabre & Mirage in Australian Service By Stewart Wilson
 2. Mirage III Colours and Markings
 3. Google Images
 4. www. airliners.net
 5. Flickr (Mirage III)
 6. ADF images.
 7. Personal images



Scheme 4.

A3-2 1980 "Aussie" Scheme I

A3-2. RAAF Base Edinburgh, S.A. 1980,
wearing the new "Aussie" scheme with the new Camera nose.
This scheme would later change slightly.

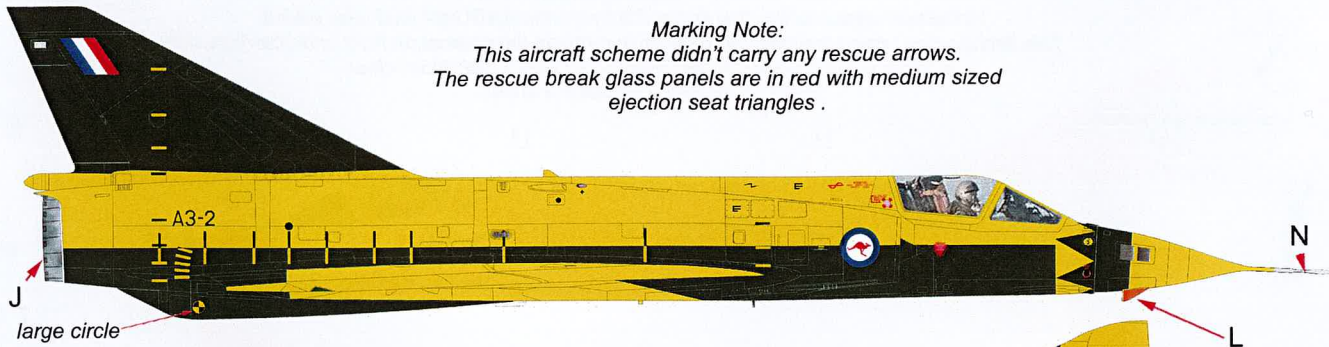
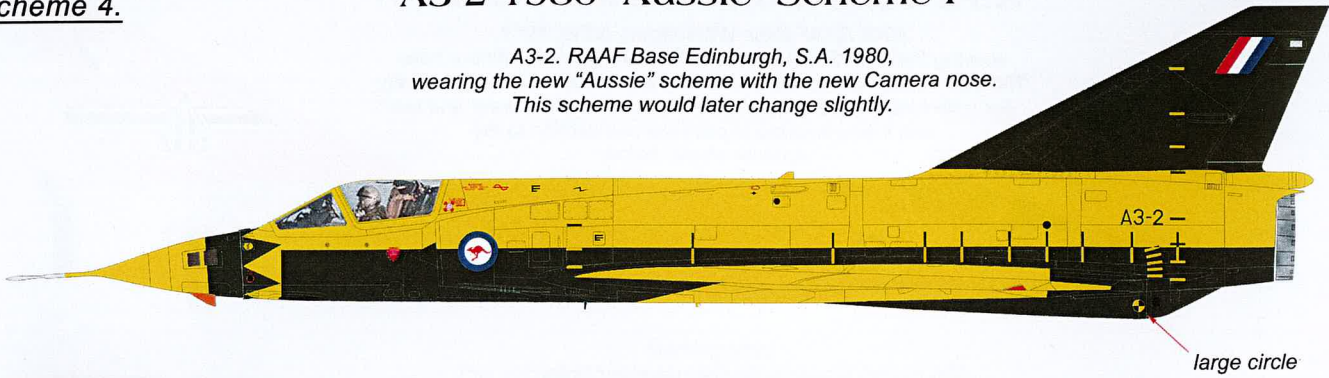

Marking Note:
This aircraft scheme didn't carry any rescue arrows.
The rescue break glass panels are in red with medium sized
ejection seat triangles .

 H	 J	 K	 L	 N
BS-224c Deep Bronze Green	Burnt Metal	BS-356 Golden Yellow	Fluro Orange	Silver

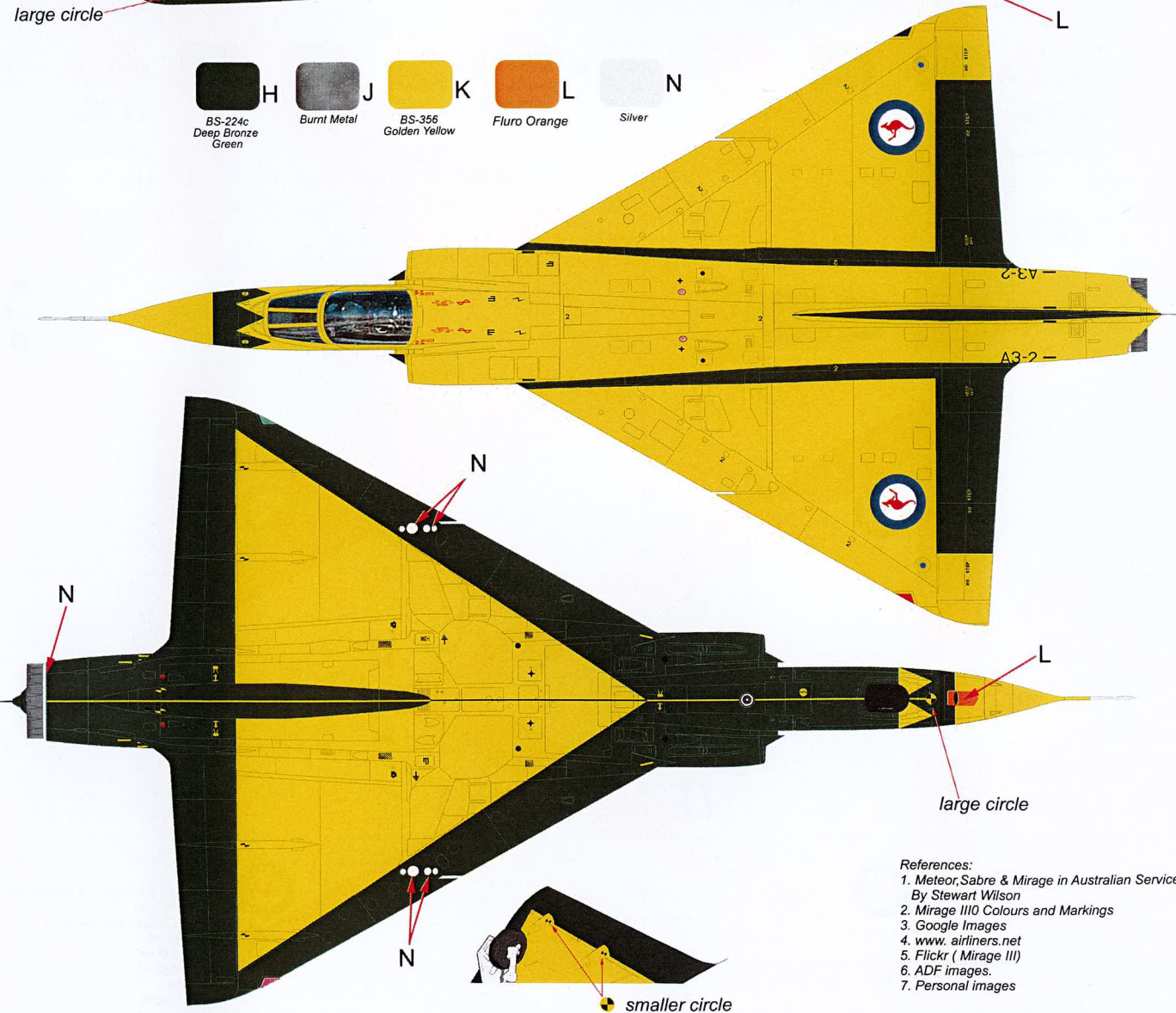

- References:
1. Meteor, Sabre & Mirage in Australian Service
By Stewart Wilson
 2. Mirage III O Colours and Markings
 3. Google Images
 4. www. airliners.net
 5. Flickr (Mirage III)
 6. ADF images.
 7. Personal images



Scheme 5.

A3-2 1981 "Aussie" Scheme II

A3-2. RAAF Base Edinburgh, S.A. 1981,
wearing a slightly different "Aussie" scheme,
this time without camera nose.

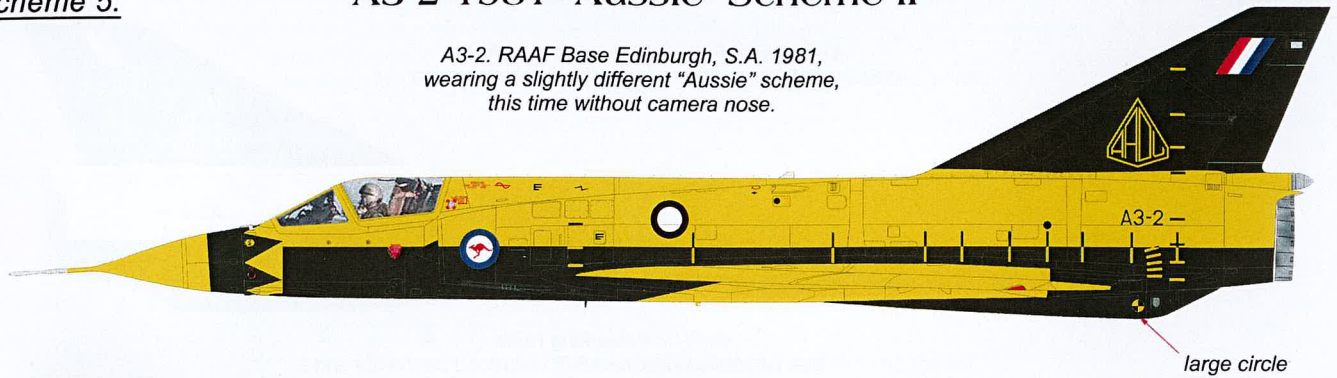

large circle

Marking Note:
This version carries the ARDU diamond on the tail and a
large black and white roundel on the mid fuselage section.

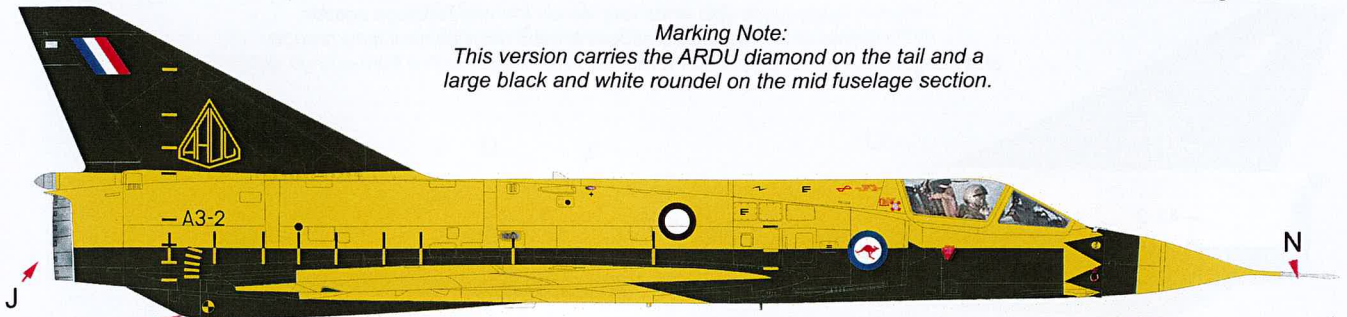

large circle

			
H	J	K	N
BS-224c Deep Bronze Green	Burnt Metal	BS-356 Golden Yellow	Silver

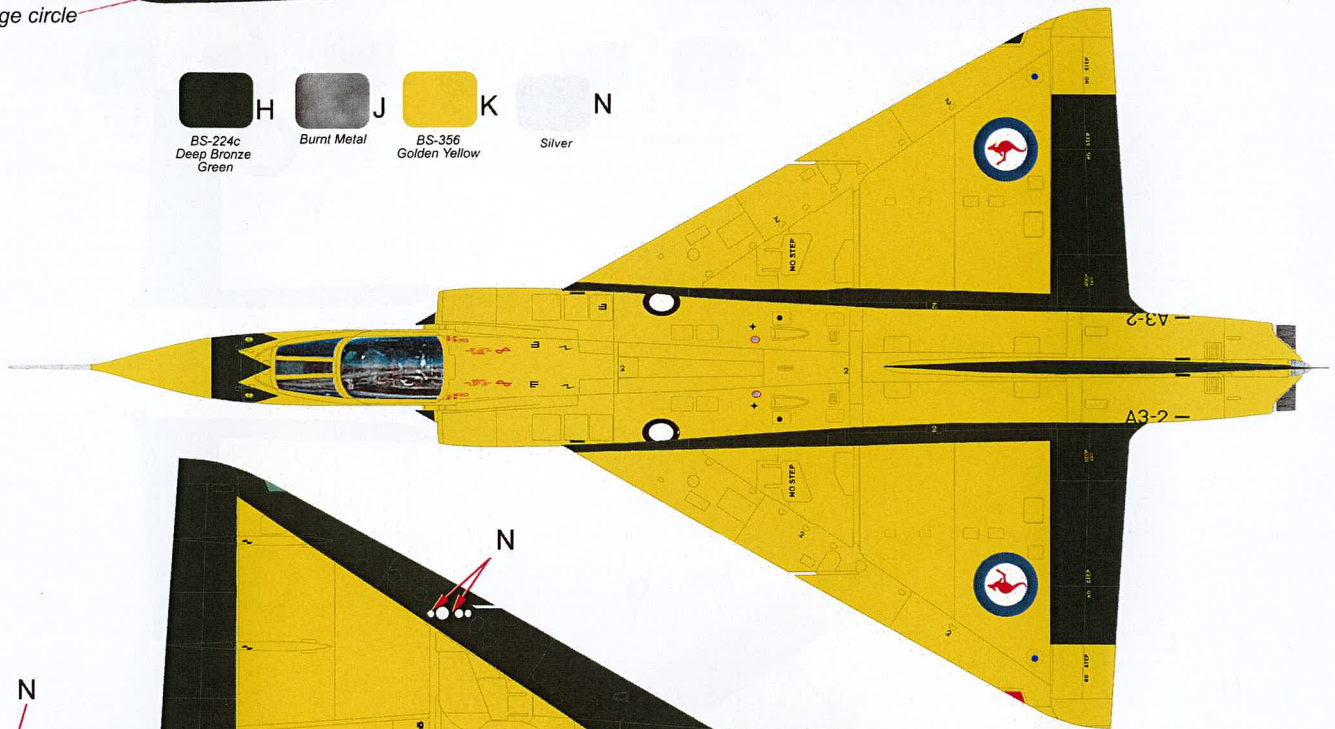

large circle

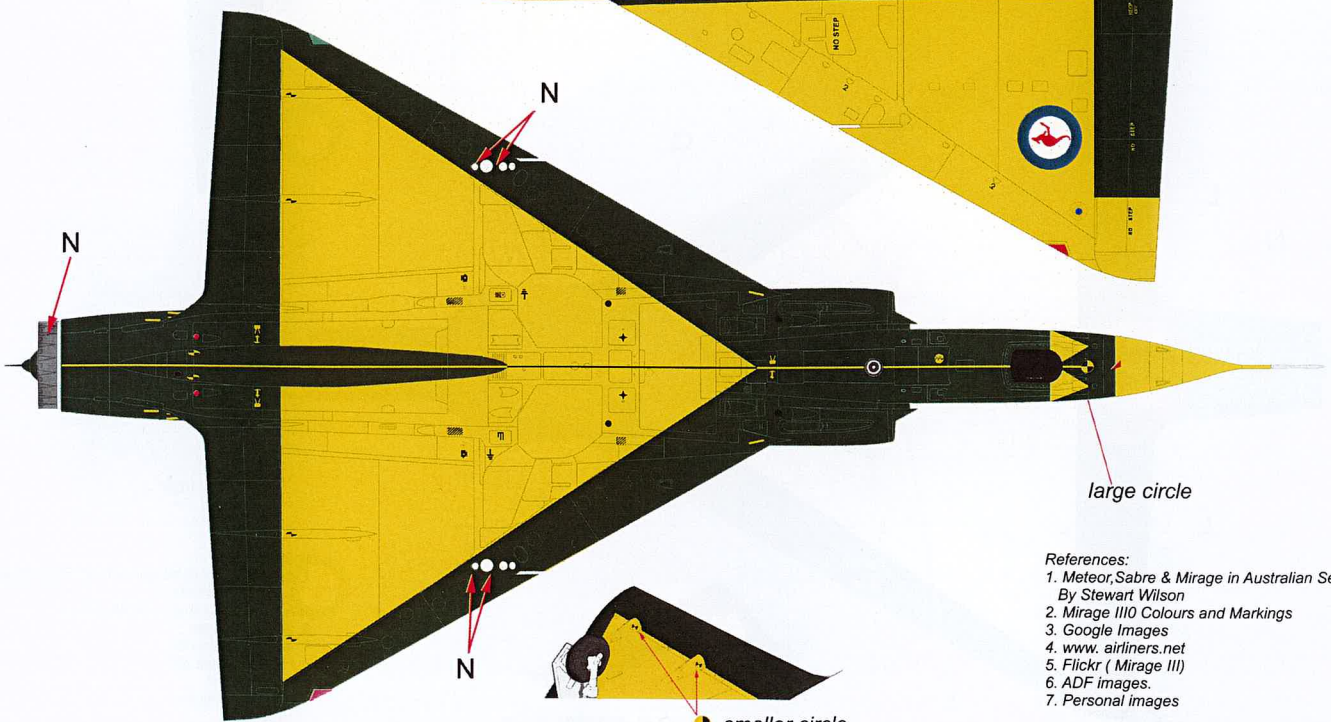

smaller circle

- References:
1. Meteor, Sabre & Mirage in Australian Service
By Stewart Wilson
 2. Mirage III Colours and Markings
 3. Google Images
 4. www.airliners.net
 5. Flickr (Mirage III)
 6. ADF images.
 7. Personal images



Scheme 6.





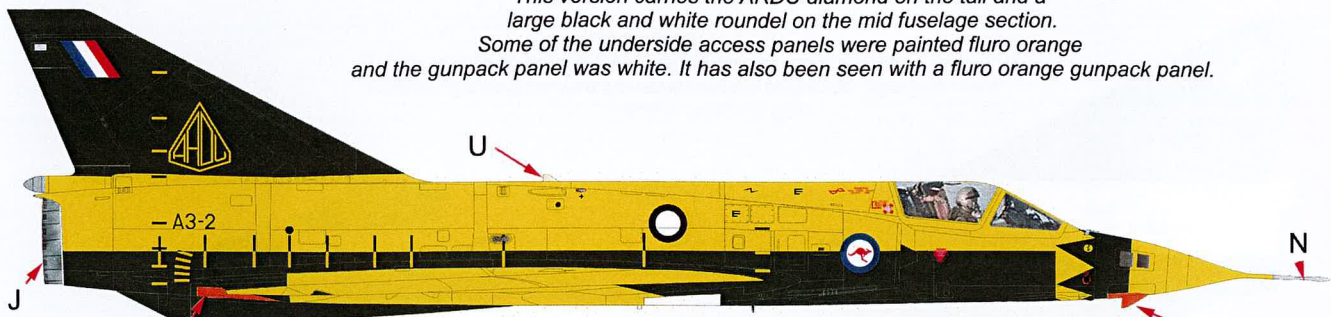

A3-2 1982 "Aussie" Scheme III

A3-2. RAAF Base Edinburgh, S.A. 1982,
wearing the "Aussie" scheme with what became the
standard camera nose.



Marking Note:
This version carries the ARDU diamond on the tail and a
large black and white roundel on the mid fuselage section.
Some of the underside access panels were painted fluro orange
and the gunpack panel was white. It has also been seen with a fluro orange gunpack panel.



	H		J		K		L		N
BS-224c Deep Bronze Green		Burnt Metal		BS-356 Golden Yellow		Fluro Orange		Silver	
UNDERSIDE		TACAN Antenna							
	Q		U						
Light Gull Grey FS-36440		BS-353 Deep Cream							

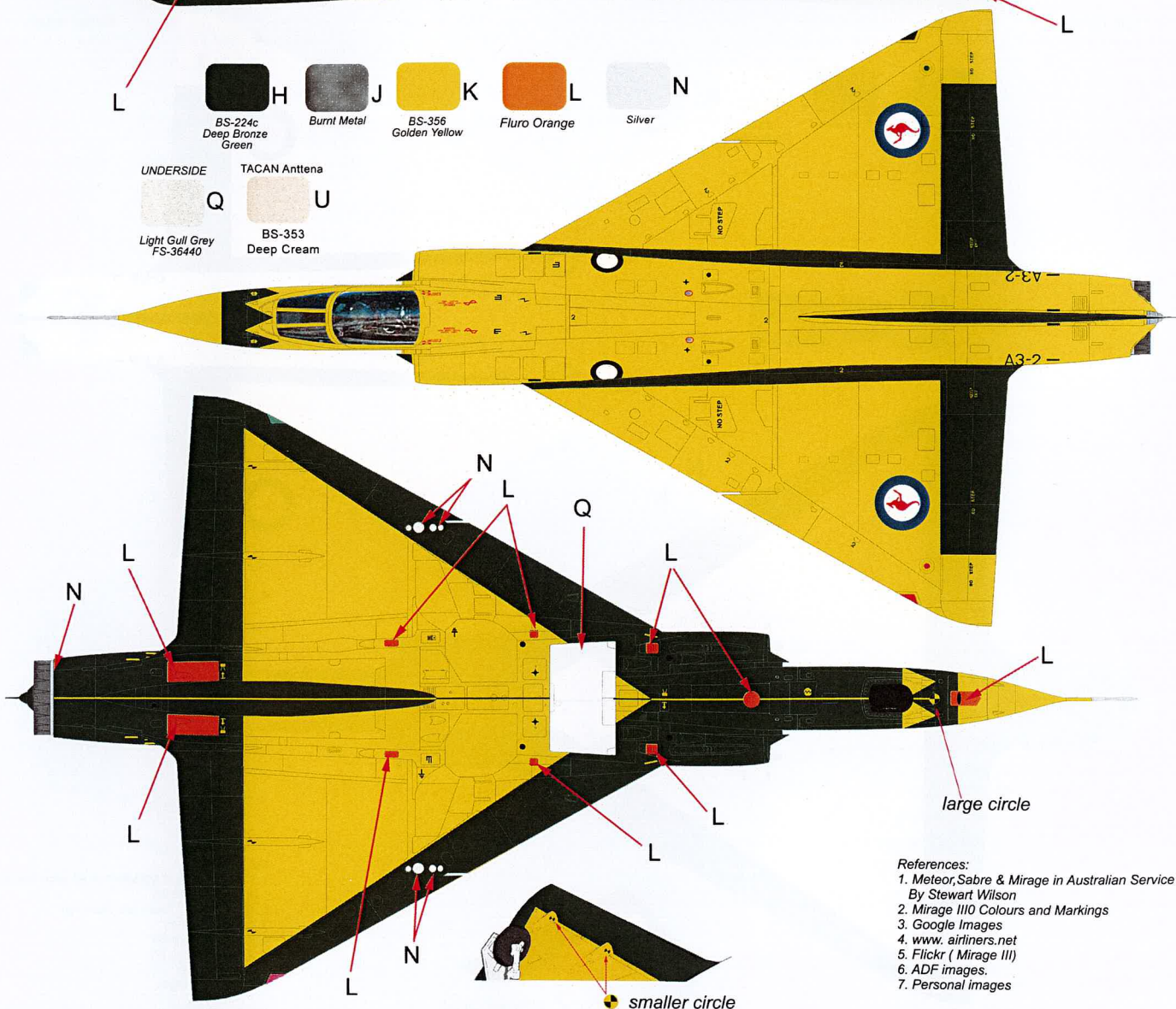

- References:
1. Meteor, Sabre & Mirage in Australian Service
By Stewart Wilson
 2. Mirage III/0 Colours and Markings
 3. Google Images
 4. www.airliners.net
 5. Flickr (Mirage III)
 6. ADF images.
 7. Personal images



Aircraft Research & Development Unit ARDU Mirage III O/D



Scheme 7.

A3-12 1988 "Lizard" Scheme II

A3-12. RAAF Base Richmond in 1988,
wearing what was to become the standard paint scheme for the Mirage IIIs.

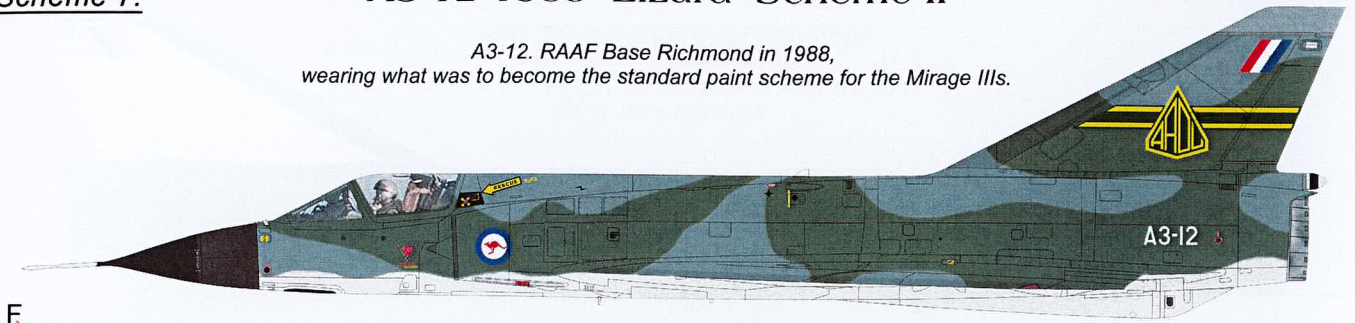

Marking Note:

This version carries a larger ARDU diamond and band on the tail.
This Lizard Scheme pattern is different to what followed.
All the leading edges are coated with a high gloss clear.
See data placement sheet.

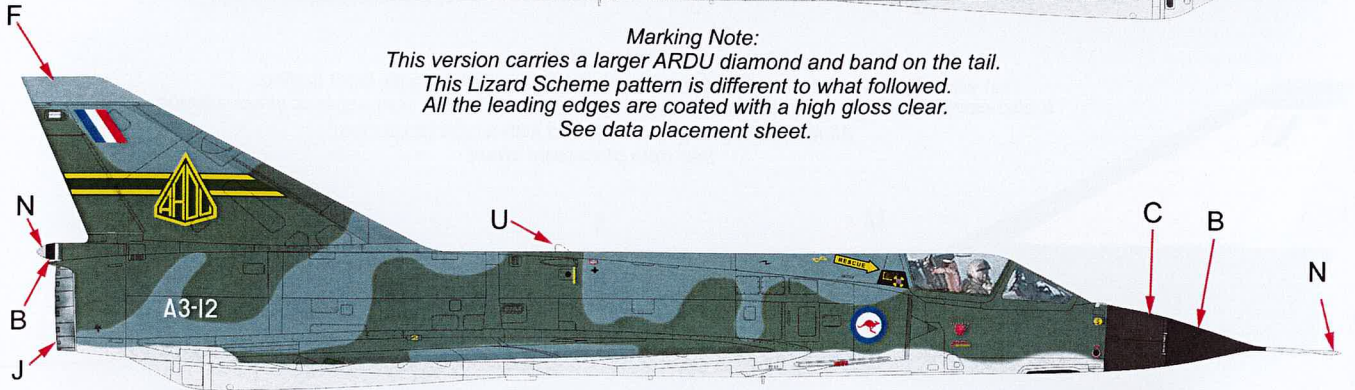

						
A	B	C	E	F	I	J
BS-538c Post Office Red	Matt Black K3/179 FS-37038	Flat Black	MATT / HIGH GLOSS BS-298c Olive Drab	Dark Ghost Grey FS-36320	MATT / HIGH GLOSS BS-640c Extra Dark Sea Grey	Burnt Metal
UNDERSIDE		TACAN Antenna				
						
Q	U	N				
Light Gull Grey FS-36440	BS-353 Deep Cream	Silver				

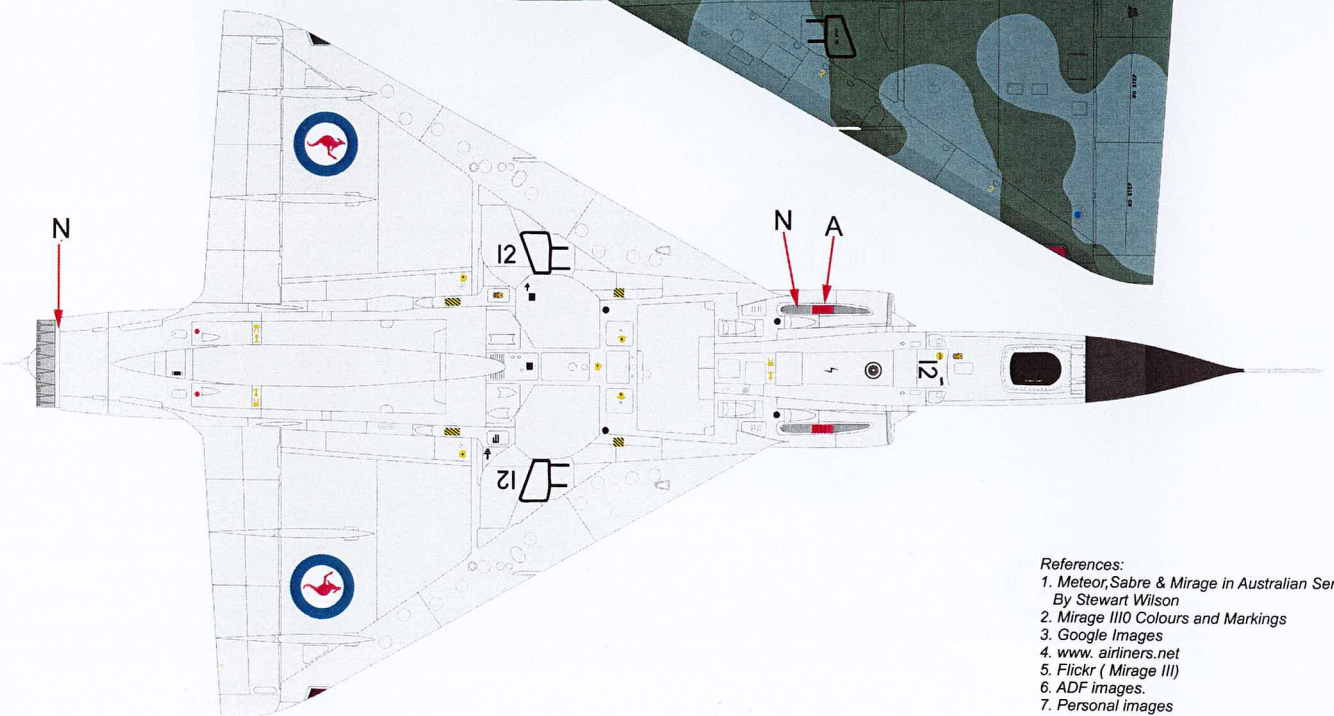
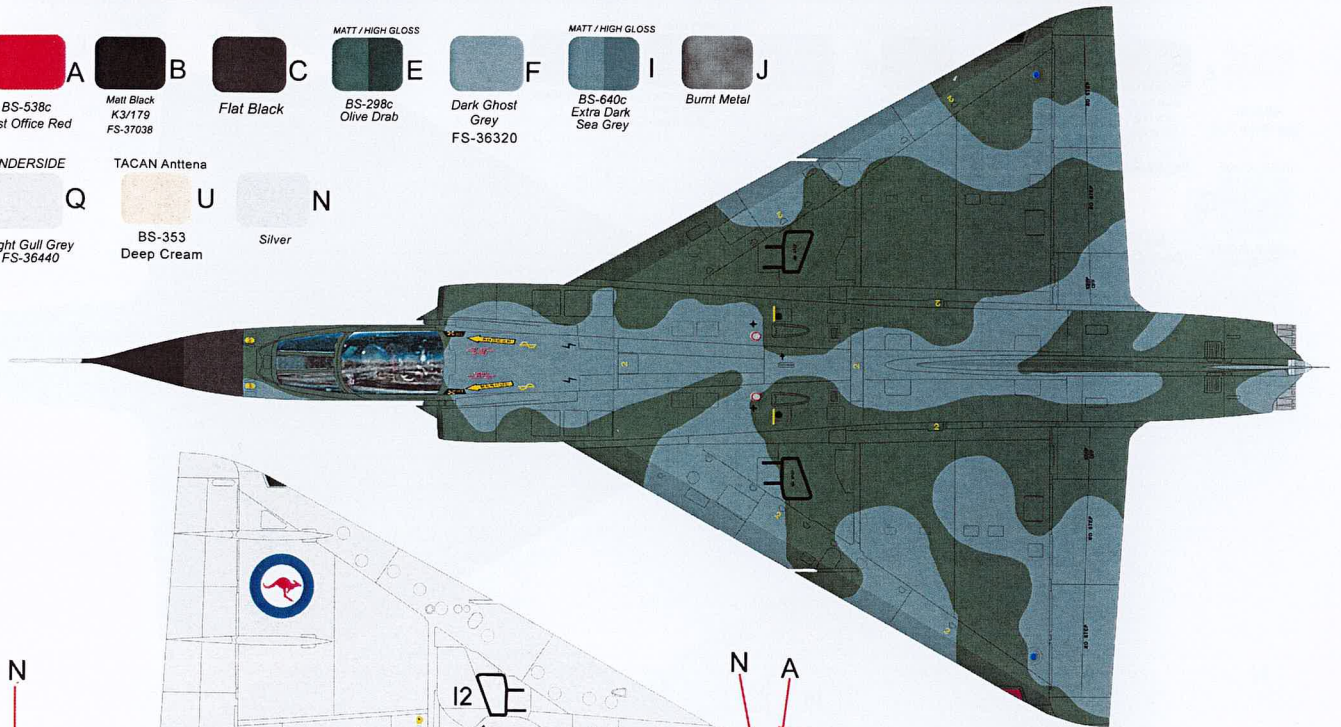

- References:
1. Meteor, Sabre & Mirage in Australian Service
By Stewart Wilson
 2. Mirage III/0 Colours and Markings
 3. Google Images
 4. www.airliners.net
 5. Flickr (Mirage III)
 6. ADF images.
 7. Personal images



Scheme 8.

A3-16 1974 "Lizard" Scheme

A3-16. RAAF Base Edinburgh, S.A. 1974.
No ARDU diamond on the tail.

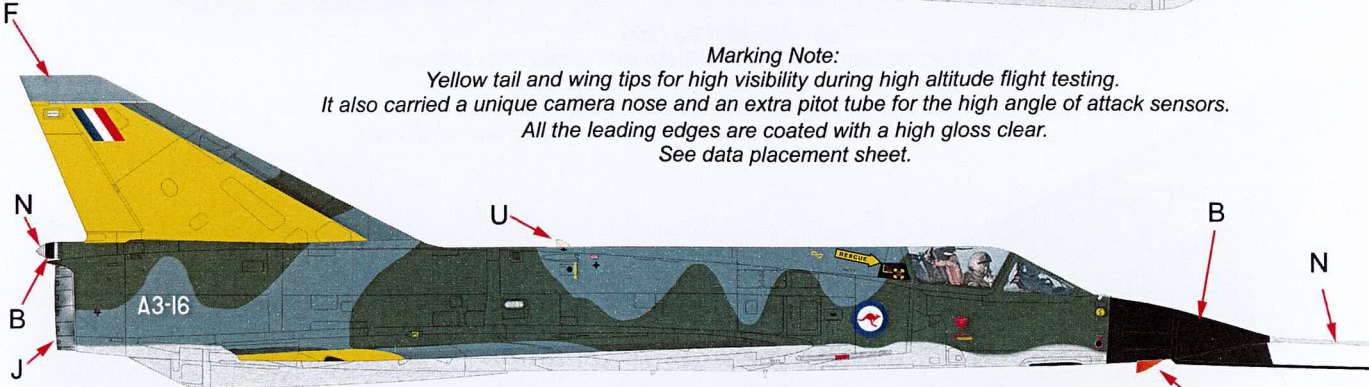
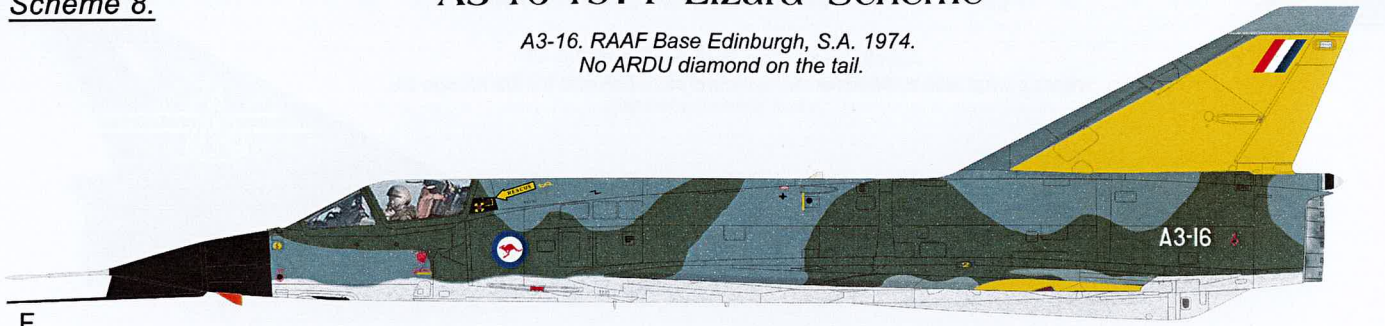

Marking Note:
Yellow tail and wing tips for high visibility during high altitude flight testing.
It also carried a unique camera nose and an extra pitot tube for the high angle of attack sensors.
All the leading edges are coated with a high gloss clear.
See data placement sheet.

BS-538c Post Office Red	Matt Black K3/179 FS-37038	Fluro Orange	MATT / HIGH GLOSS BS-298c Olive Drab	Dark Ghost Grey FS-36320	MATT / HIGH GLOSS BS-640c Extra Dark Sea Grey	Burnt Metal
UNDERSIDE		TACAN Antenna				
			Silver	BS-356 Golden Yellow		
Light Gull Grey FS-36440	BS-353 Deep Cream					

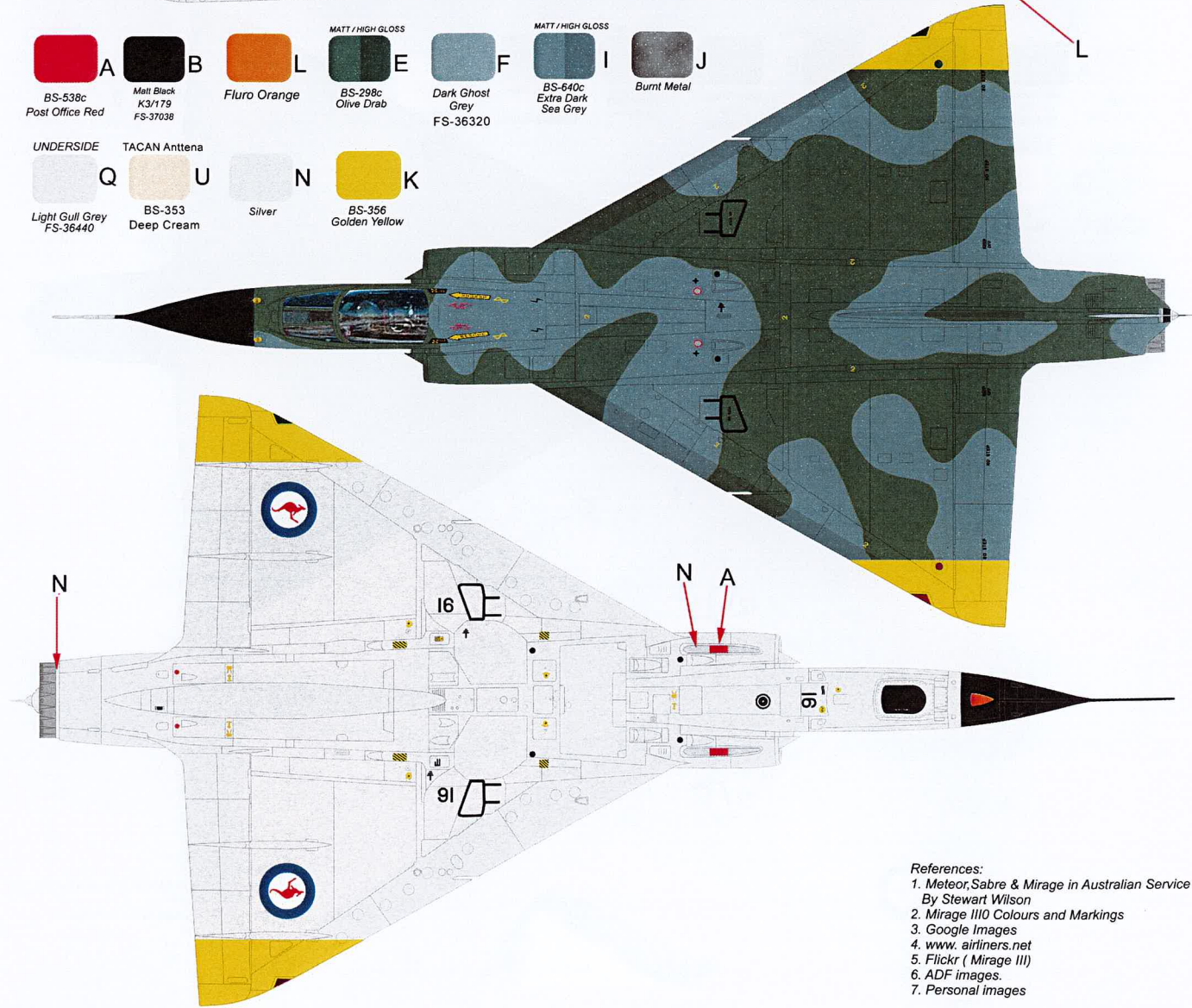

References:

- Meteor, Sabre & Mirage in Australian Service
By Stewart Wilson
- Mirage III Colours and Markings
- Google Images
- www.airliners.net
- Flickr (Mirage III)
- ADF images.
- Personal images



Aircraft Research & Development Unit ARDU Mirage III O/D



Scheme 9.

A3-16 2000 "Lizard" Scheme

A3-16. RAAF Base Edinburgh, S.A. 2000, wearing the yellow tail and wing tips with the ARDU diamond in black. This aircraft is now a static display aircraft at RAAF Base Edinburgh.

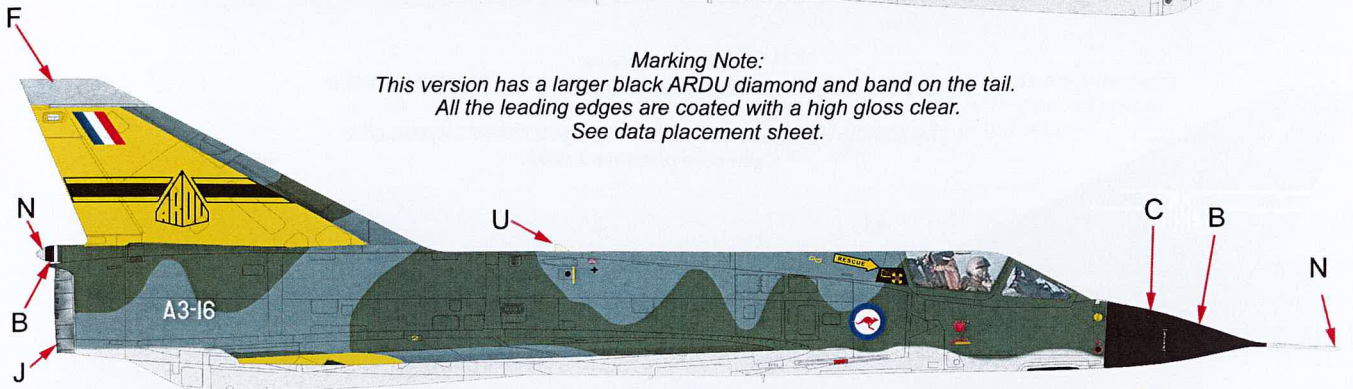
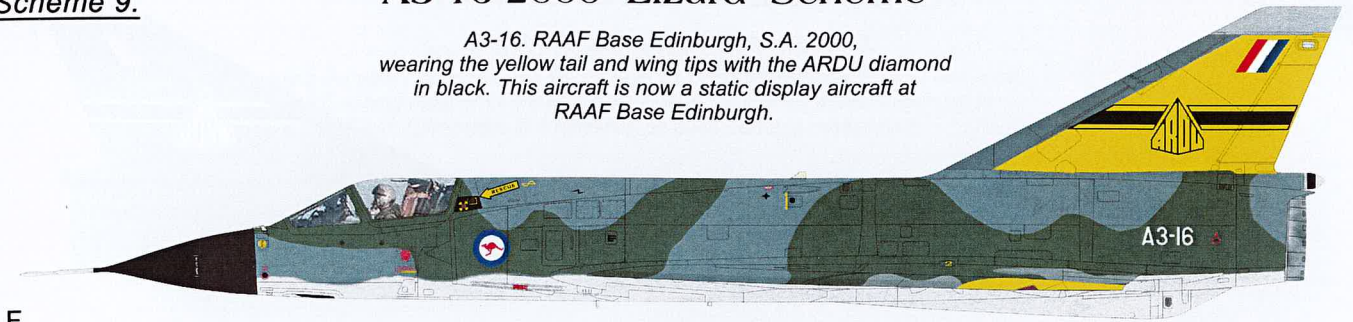

Marking Note:
This version has a larger black ARDU diamond and band on the tail.
All the leading edges are coated with a high gloss clear.
See data placement sheet.

						
A BS-538c Post Office Red	B Matt Black K3/179 FS-37038	C Flat Black	E BS-298c Olive Drab	F Dark Ghost Grey FS-36320	I BS-640c Extra Dark Sea Grey	J Burnt Metal
UNDERSIDE	TACAN Antenna					
						
Q Light Gull Grey FS-36440	U BS-353 Deep Cream	N Silver	K BS-356 Golden Yellow			

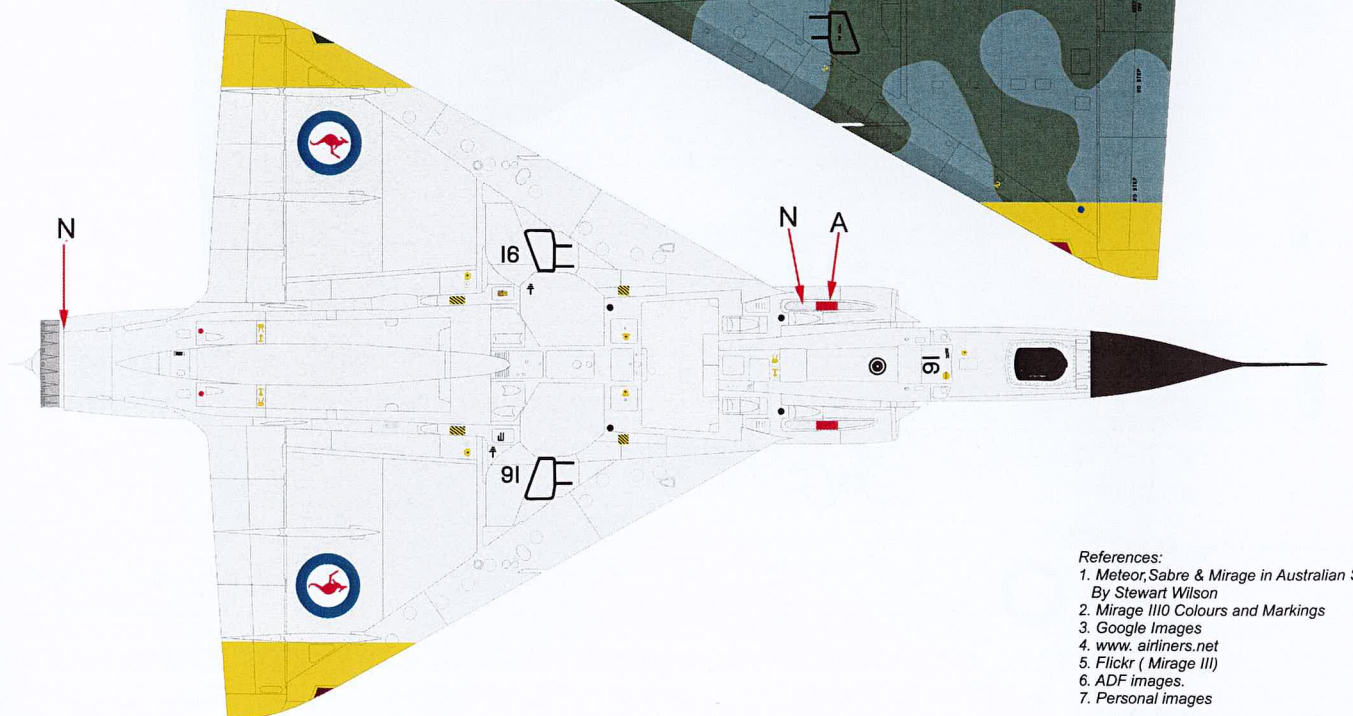
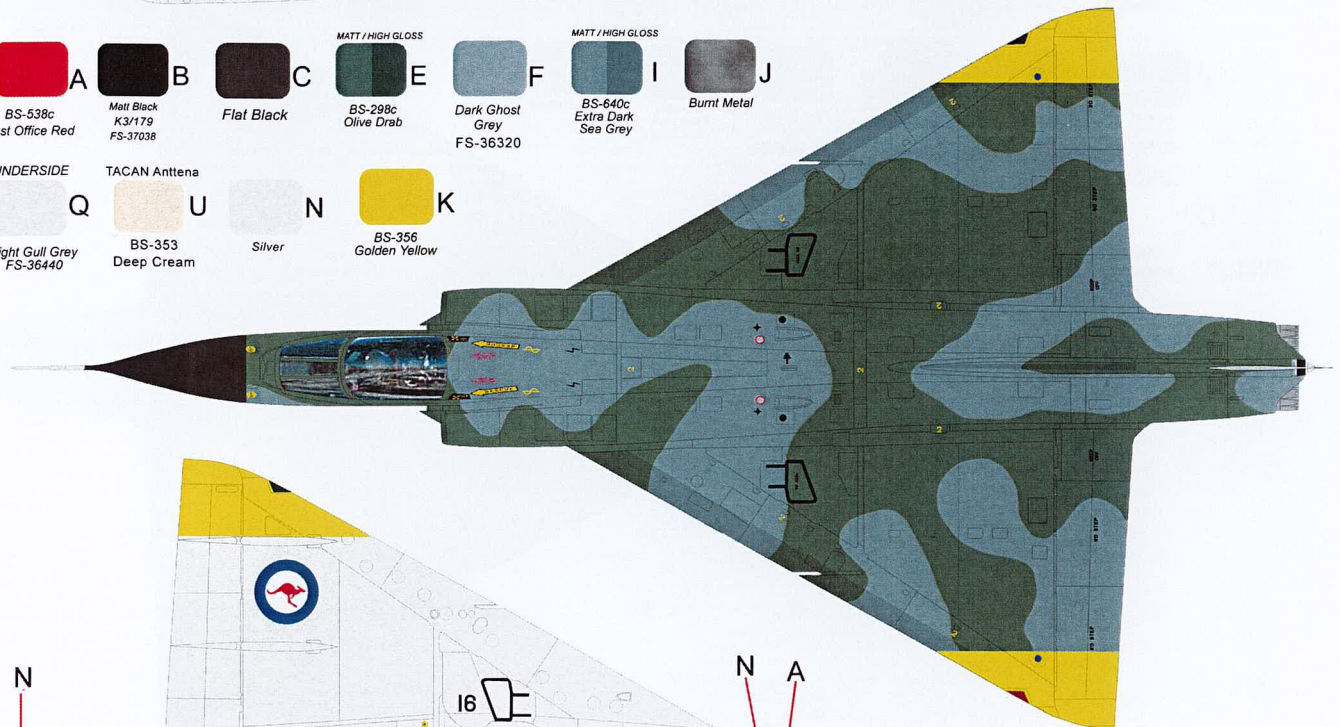

- References:
1. Meteor, Sabre & Mirage in Australian Service By Stewart Wilson
 2. Mirage III Colours and Markings
 3. Google Images
 4. www.airliners.net
 5. Flickr (Mirage III)
 6. ADF images.
 7. Personal images



Scheme 10.

A3-53 1989 "Lizard" Scheme

A3-53. RAAF Base Edinburgh, S.A. 1989,
ARDU diamond and band with bold letters.

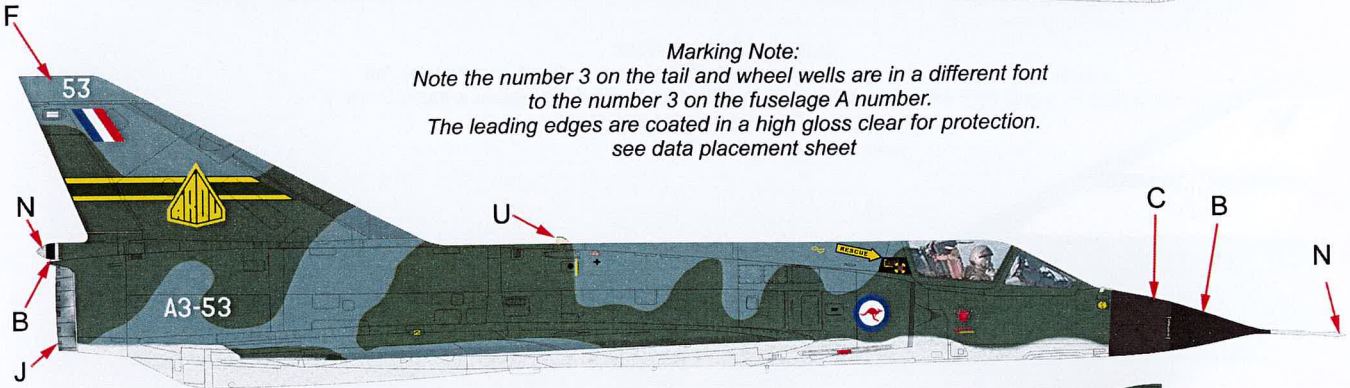
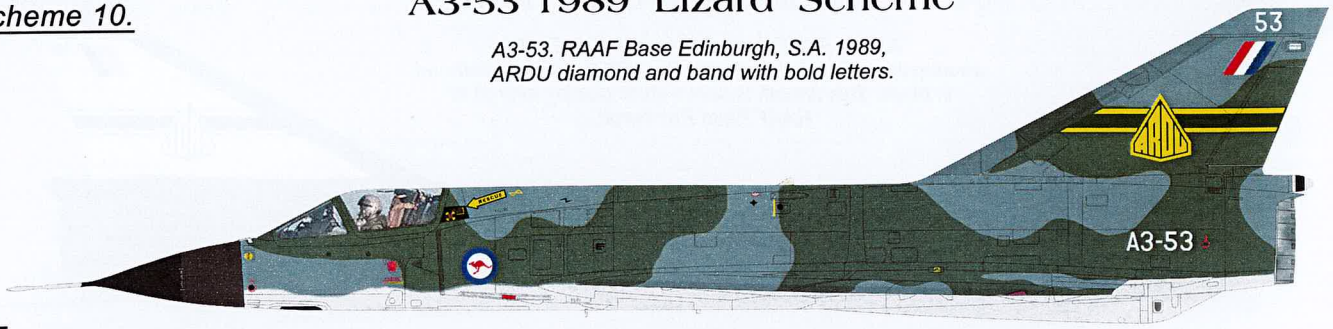

Marking Note:
Note the number 3 on the tail and wheel wells are in a different font
to the number 3 on the fuselage A number.
The leading edges are coated in a high gloss clear for protection.
see data placement sheet

 A BS-538c Post Office Red	 B Matt Black K3/179 FS-37036	 C Flat Black	 E MATT / HIGH GLOSS BS-298c Olive Drab	 F Dark Ghost Grey FS-36320	 I MATT / HIGH GLOSS BS-640c Extra Dark Sea Grey	 J Burnt Metal
UNDERSIDE		TACAN Antenna				
 Q Light Gull Grey FS-36440	 U BS-353 Deep Cream	 N Silver				

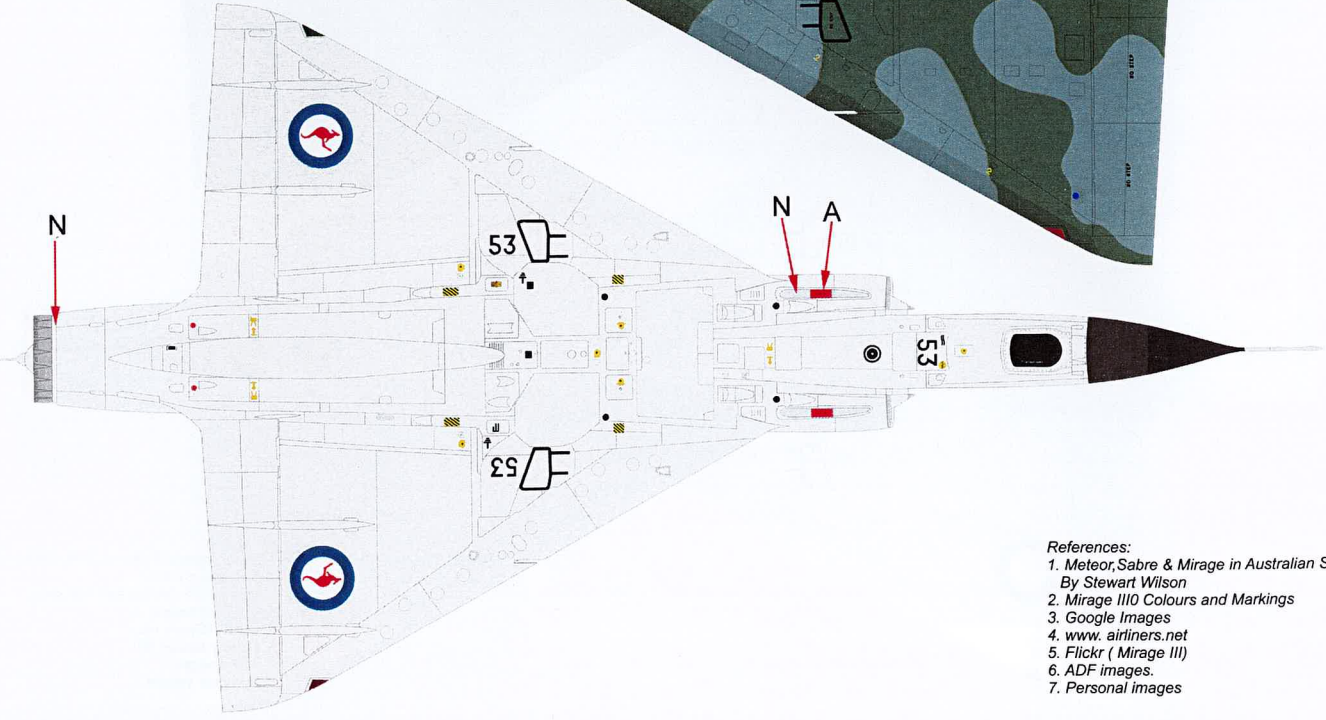
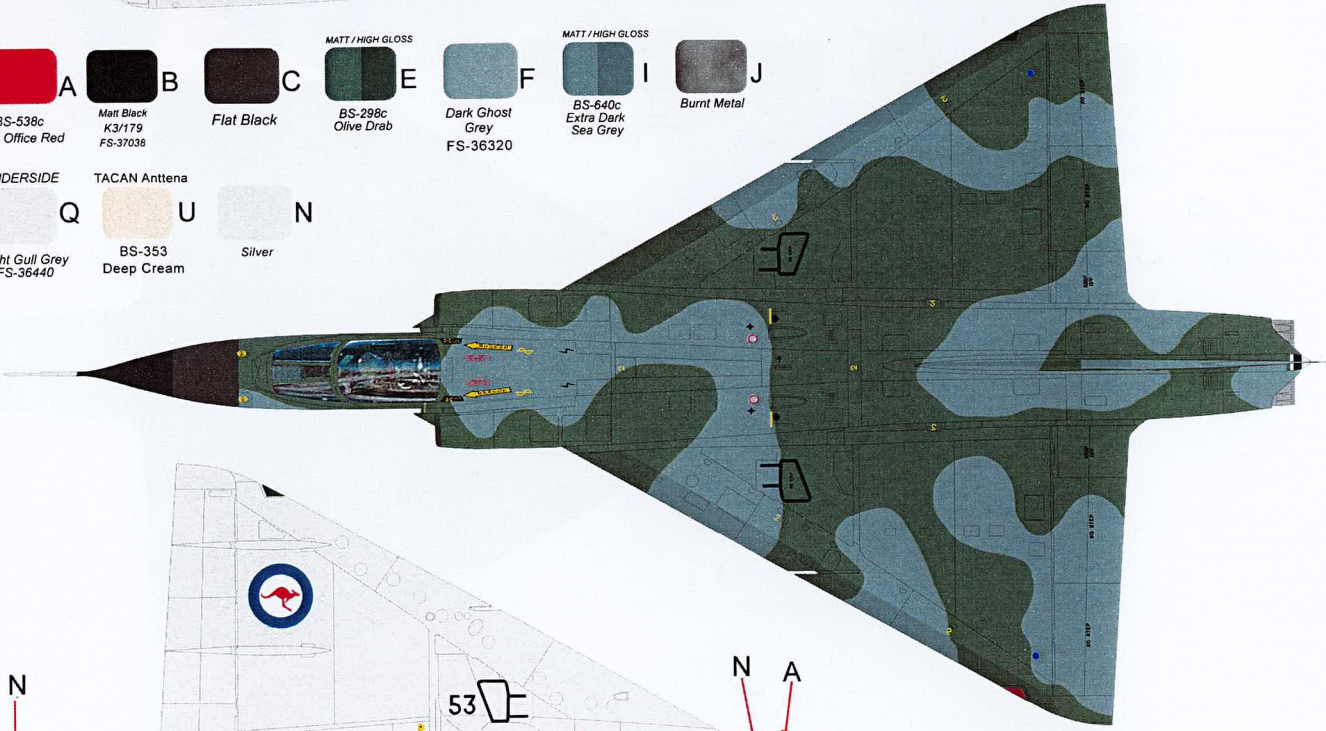

References:
1. Meteor, Sabre & Mirage in Australian Service
By Stewart Wilson
2. Mirage III/0 Colours and Markings
3. Google Images
4. www. airliners.net
5. Flickr (Mirage III)
6. ADF images.
7. Personal Images



Aircraft Research & Development Unit ARDU Mirage III O/D



Scheme 11.

A3-76 1969 Lizard Scheme

A3-76. RAAF Base Williamtown, NSW 1969.
Wearing the new Lizard scheme with a high viz dayglow orange strip and test nose.
A3-76 served most of its life with ARDU, until 1984 when it was written off at RAAF Edinburgh, S.A following an undercarriage malfunction.

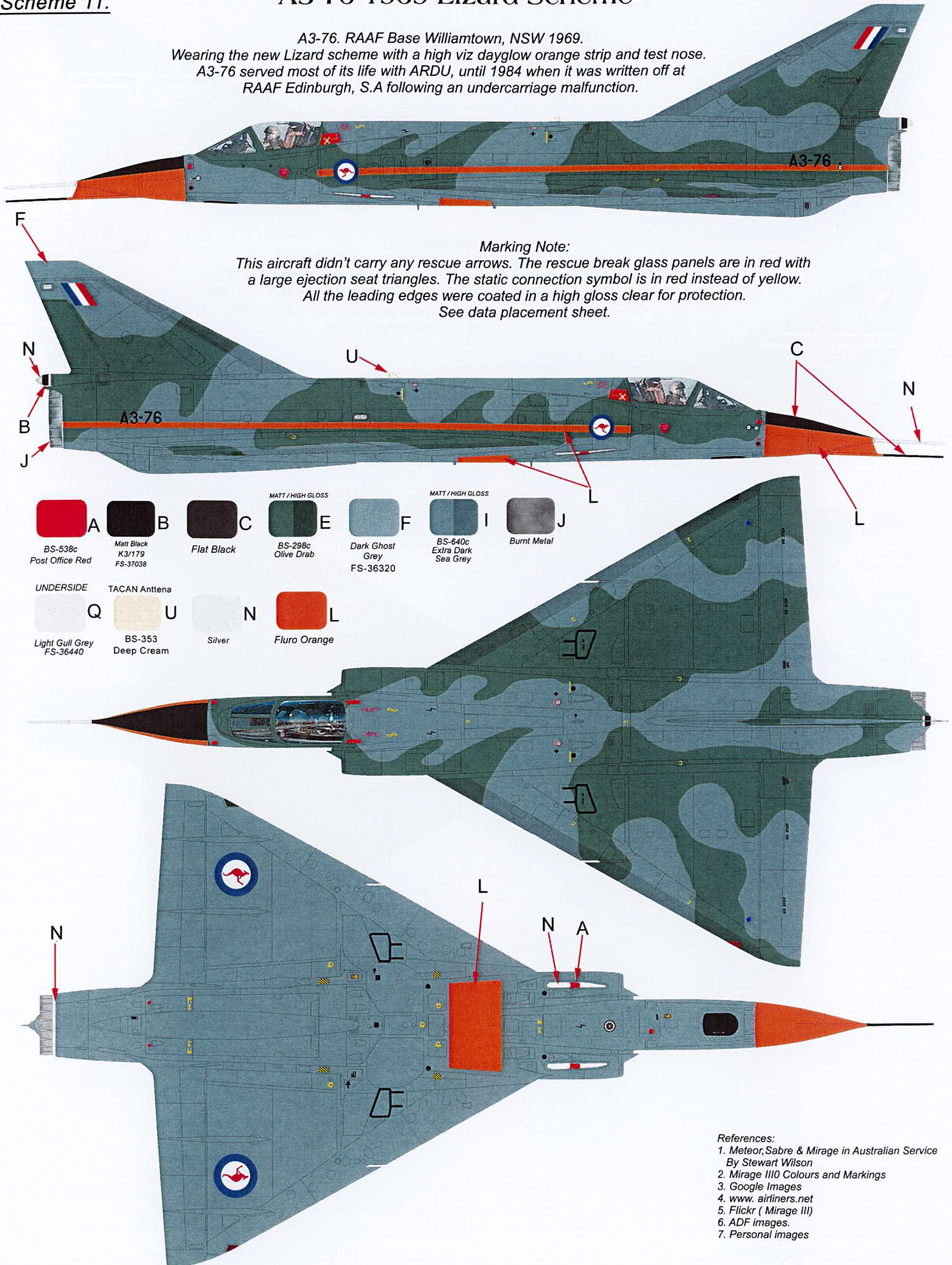

- References:
1. Meteor, Sabre & Mirage in Australian Service By Stewart Wilson
 2. Mirage III/0 Colours and Markings
 3. Google Images
 4. www. airliners.net
 5. Flickr (Mirage III)
 6. ADF images.
 7. Personal images



Scheme 12.

A3-76 1984 "Lizard" Scheme

A3-76 RAAF Base Edinburgh, S.A. 1984,
wearing the standard ARDU diamond and band tail
with a yellow and black camera nose.

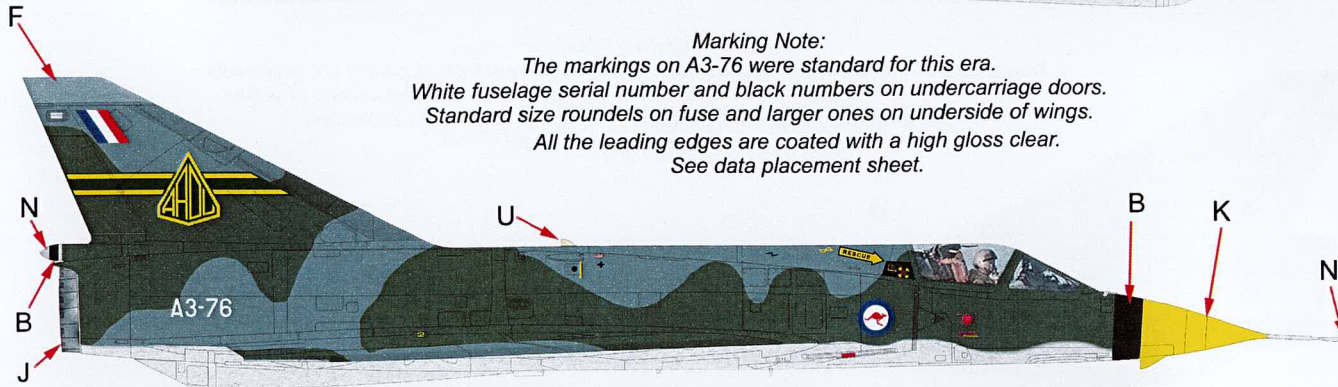
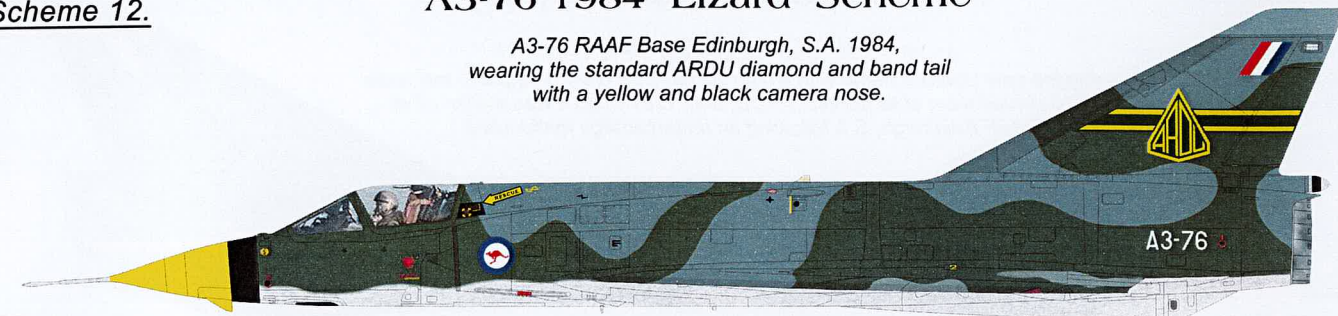

Marking Note:
The markings on A3-76 were standard for this era.
White fuselage serial number and black numbers on undercarriage doors.
Standard size roundels on fuse and larger ones on underside of wings.
All the leading edges are coated with a high gloss clear.
See data placement sheet.

 A	 B	 C	MATT / HIGH GLOSS	 E	 F	MATT / HIGH GLOSS	 J
BS-538c Post Office Red	Matt Black K3/179 FS-37038	Flat Black		BS-298c Olive Drab	Dark Ghost Grey FS-36320		BS-640c Extra Dark Sea Grey
UNDERSIDE	TACAN Antenna						
 Q	 U	 N		 K			
Light Gull Grey FS-36440	BS-353 Deep Cream	Silver		BS-356 Golden Yellow			

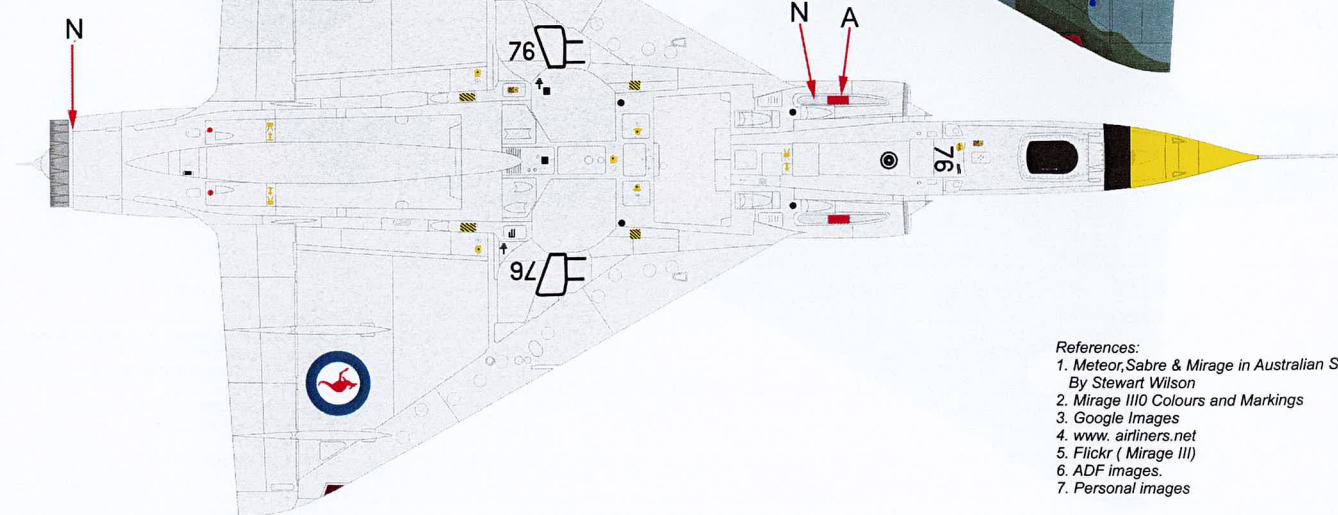
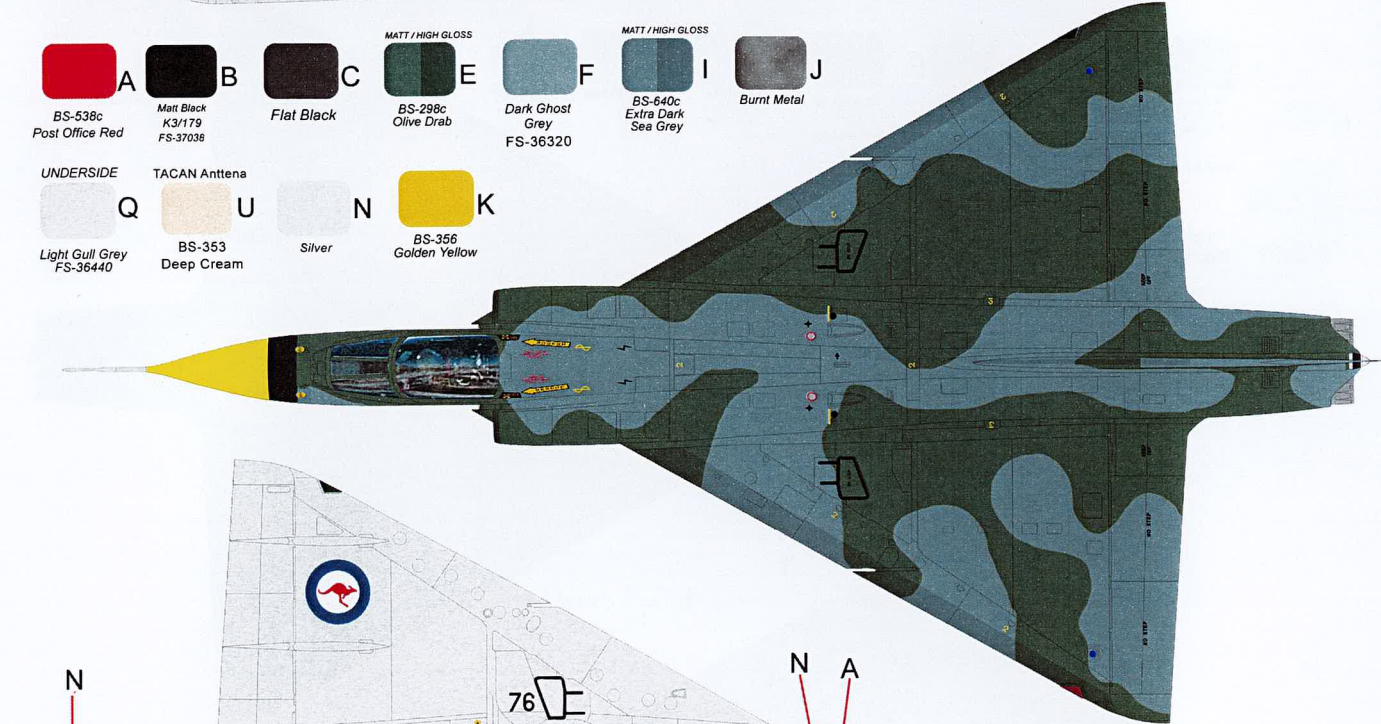

- References:
1. Meteor, Sabre & Mirage in Australian Service
By Stewart Wilson
 2. Mirage III Colours and Markings
 3. Google Images
 4. www.airliners.net
 5. Flickr (Mirage III)
 6. ADF images.
 7. Personal images



Aircraft Research & Development Unit ARDU Mirage III O/D



Scheme 13.

A3-101 1988 Lizard Scheme

A3-101. RAAF Base Williamtown, NSW, 1988.
A3-101 first served 2 OCU then spent the rest of its life with ARDU until 1989 before being sold to Pakistan in 1990.

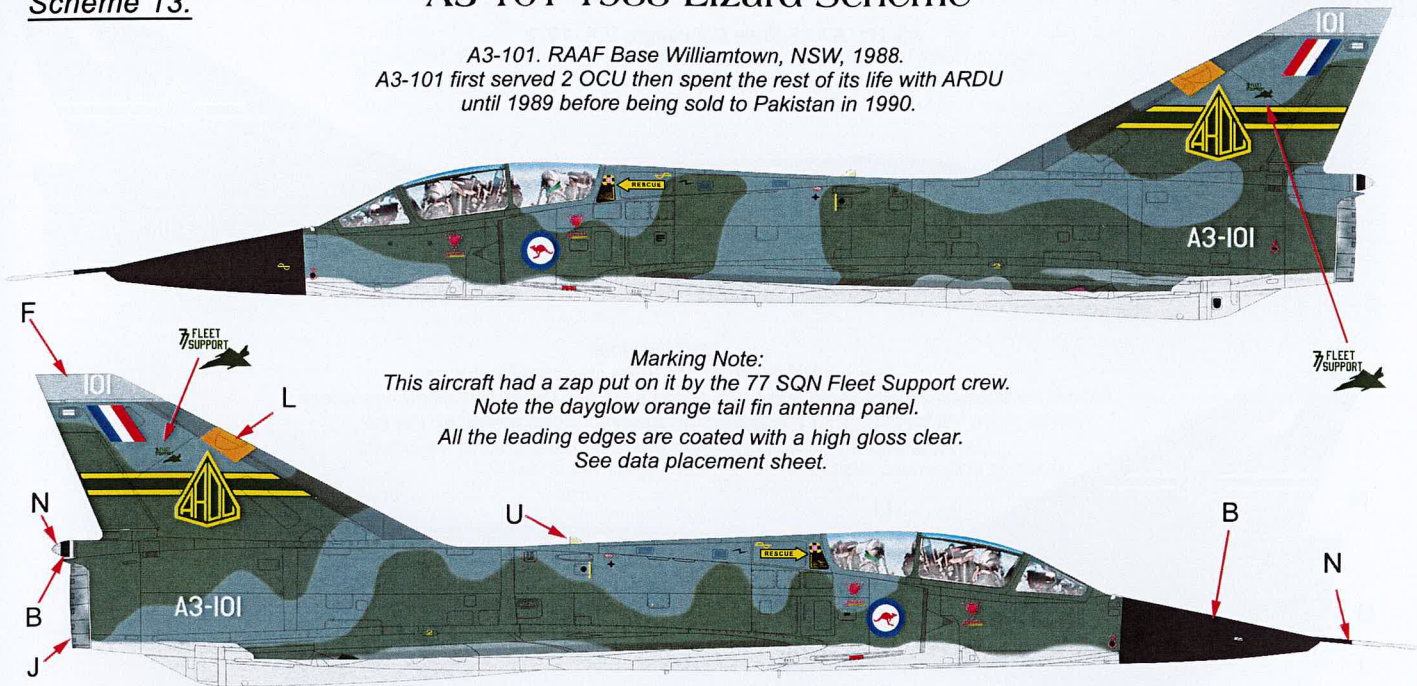

Marking Note:
This aircraft had a zap put on it by the 77 SQN Fleet Support crew.
Note the dayglow orange tail fin antenna panel.
All the leading edges are coated with a high gloss clear.
See data placement sheet.

A BS-538c Post Office Red	B Matt Black K3/179 FS-37038	C Flat Black	E BS-298c Olive Drab	F Dark Ghost Grey FS-36320	I BS-640c Extra Dark Sea Grey	J Burnt Metal
UNDERSIDE		TACAN Antenna				
Q Light Gull Grey FS-36440	U BS-353 Deep Cream	N Silver	L Fluro Orange			

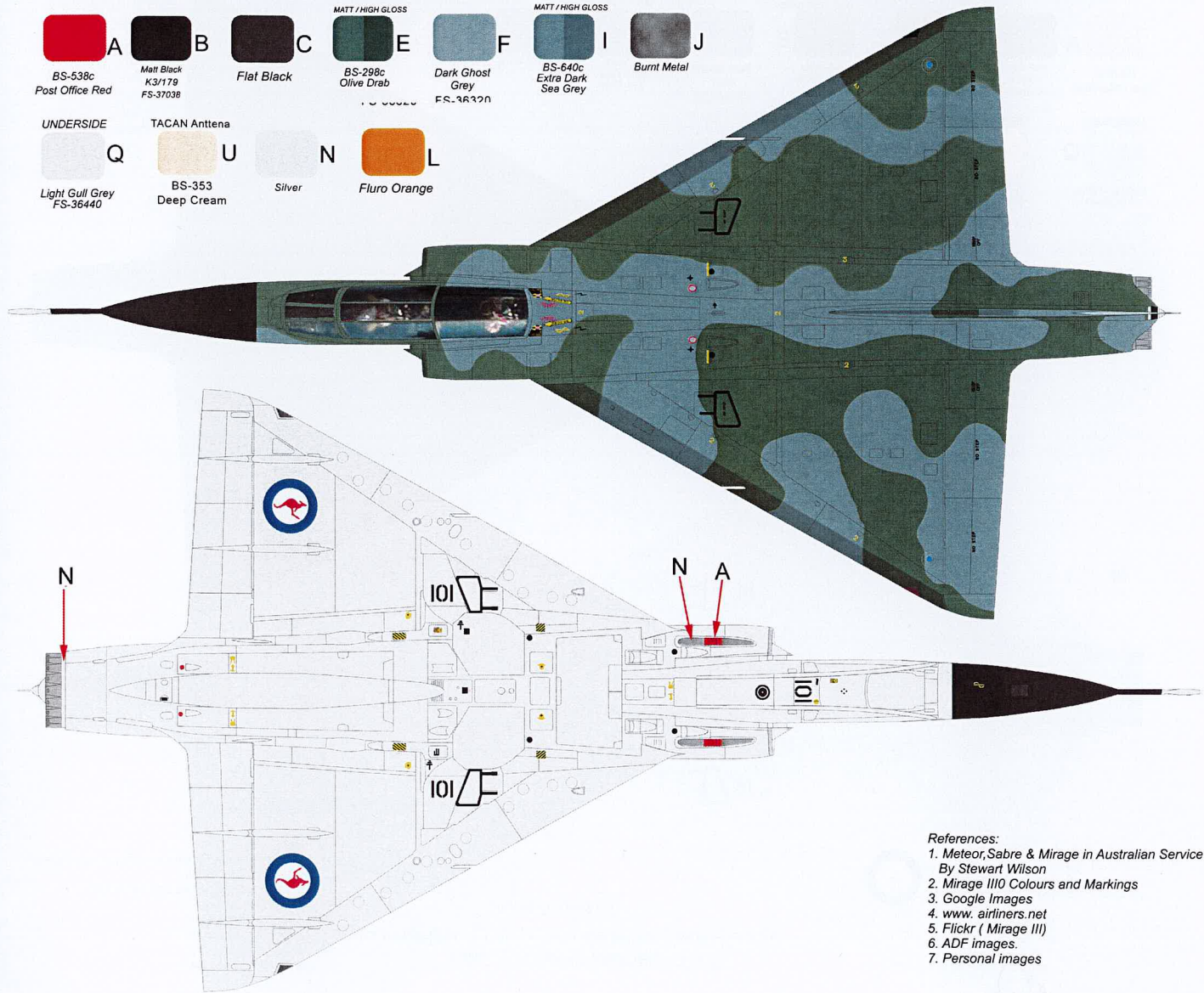

- References:
1. Meteor, Sabre & Mirage in Australian Service
By Stewart Wilson
 2. Mirage III/O Colours and Markings
 3. Google Images
 4. www. airliners.net
 5. Flickr (Mirage III)
 6. ADF images.
 7. Personal images



Scheme 14.

A3-111 1978 "Lizard" Scheme

A3-111. RAAF Base Edinburgh, S.A. 1978.

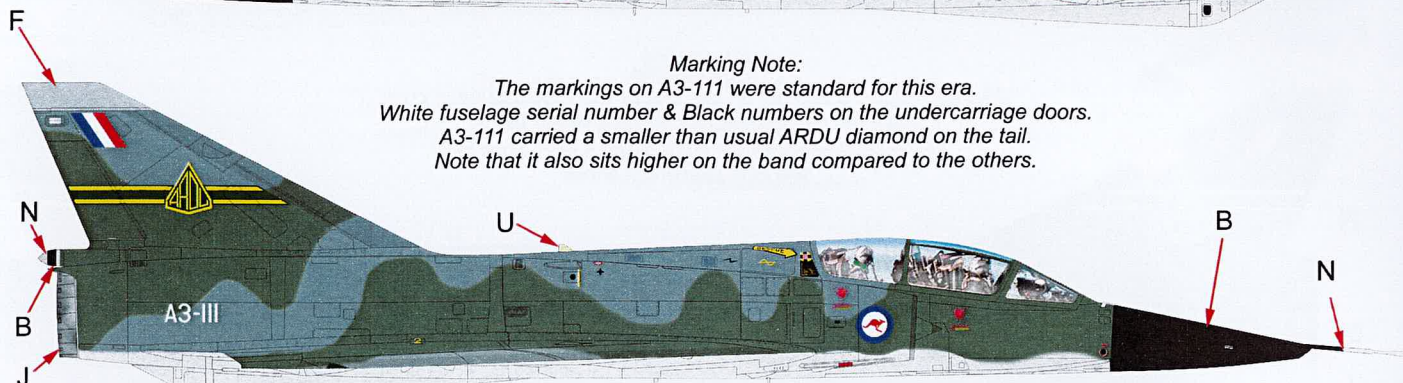
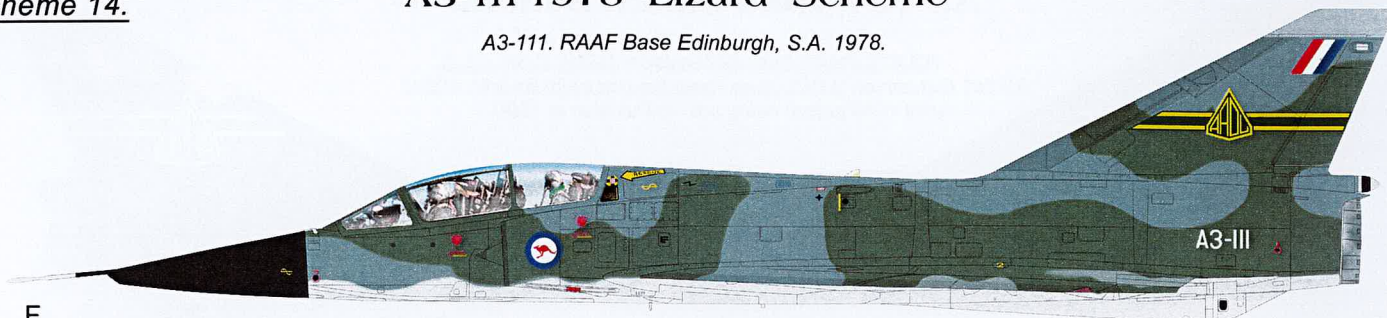

Marking Note:
The markings on A3-111 were standard for this era.
White fuselage serial number & Black numbers on the undercarriage doors.
A3-111 carried a smaller than usual ARDU diamond on the tail.
Note that it also sits higher on the band compared to the others.

A BS-538c Post Office Red	B Matt Black K3/179 FS-37038	C Flat Black	E MATT / HIGH GLOSS BS-298c Olive Drab	F MATT / HIGH GLOSS Dark Ghost Grey FS-36320	I MATT / HIGH GLOSS BS-640c Extra Dark Sea Grey	J Burnt Metal
UNDERSIDE		TACAN Antenna				
Q Light Gull Grey FS-36440	U BS-353 Deep Cream	N Silver				

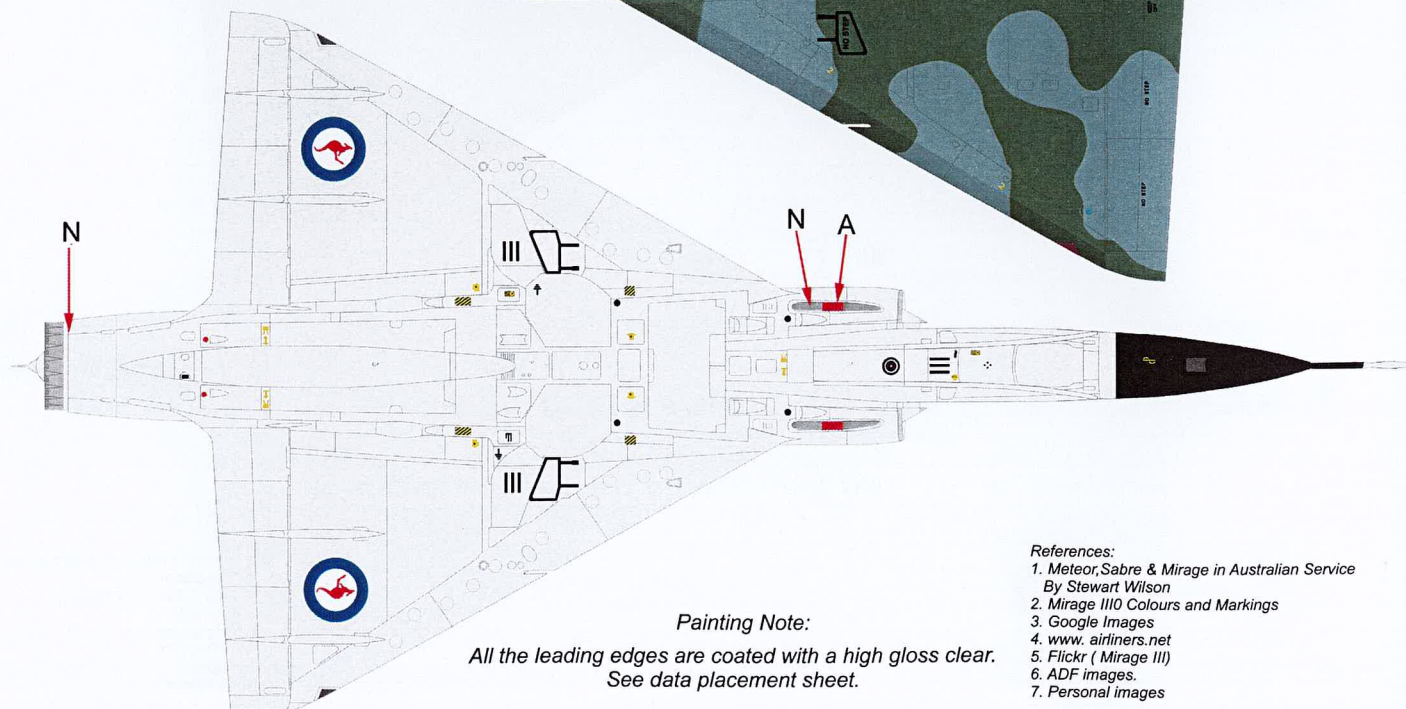
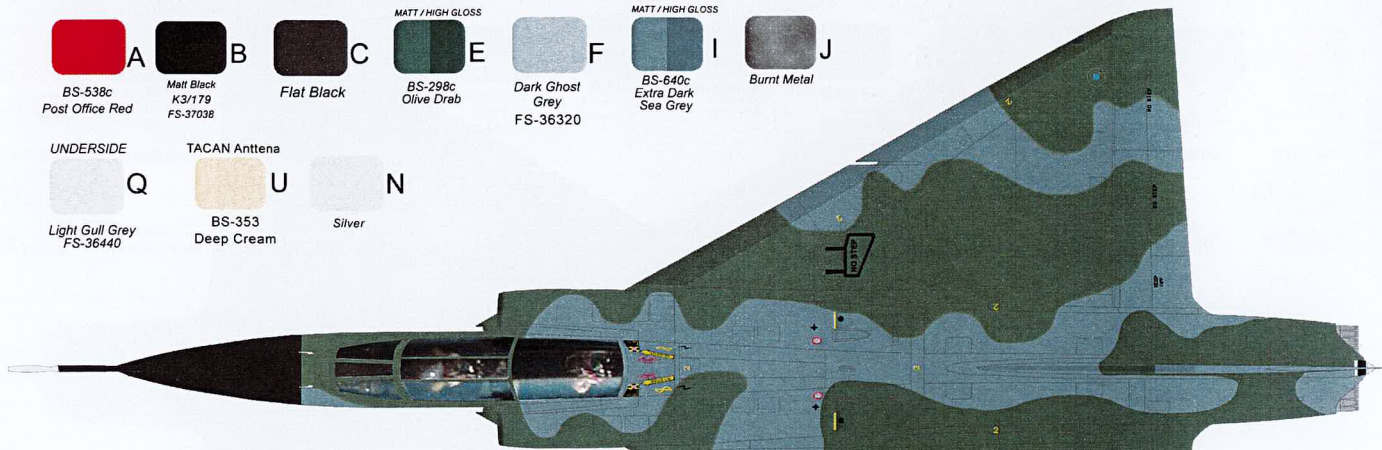

Painting Note:
All the leading edges are coated with a high gloss clear.
See data placement sheet.

- References:**
1. Meteor, Sabre & Mirage in Australian Service By Stewart Wilson
 2. Mirage III/O Colours and Markings
 3. Google Images
 4. www.airliners.net
 5. Flickr (Mirage III)
 6. ADF images.
 7. Personal images



Aircraft Research & Development Unit ARDU Mirage III O/D



Scheme 15.

A3-112 1988 Lizard Scheme

A3-112. RAAF Base Edinburgh, S.A 1975, wearing the standard lizard scheme.
A3-112 first served with 2 OCU then spent the rest of its life with ARDU
until 1989 before being sold to Pakistan in 1990.

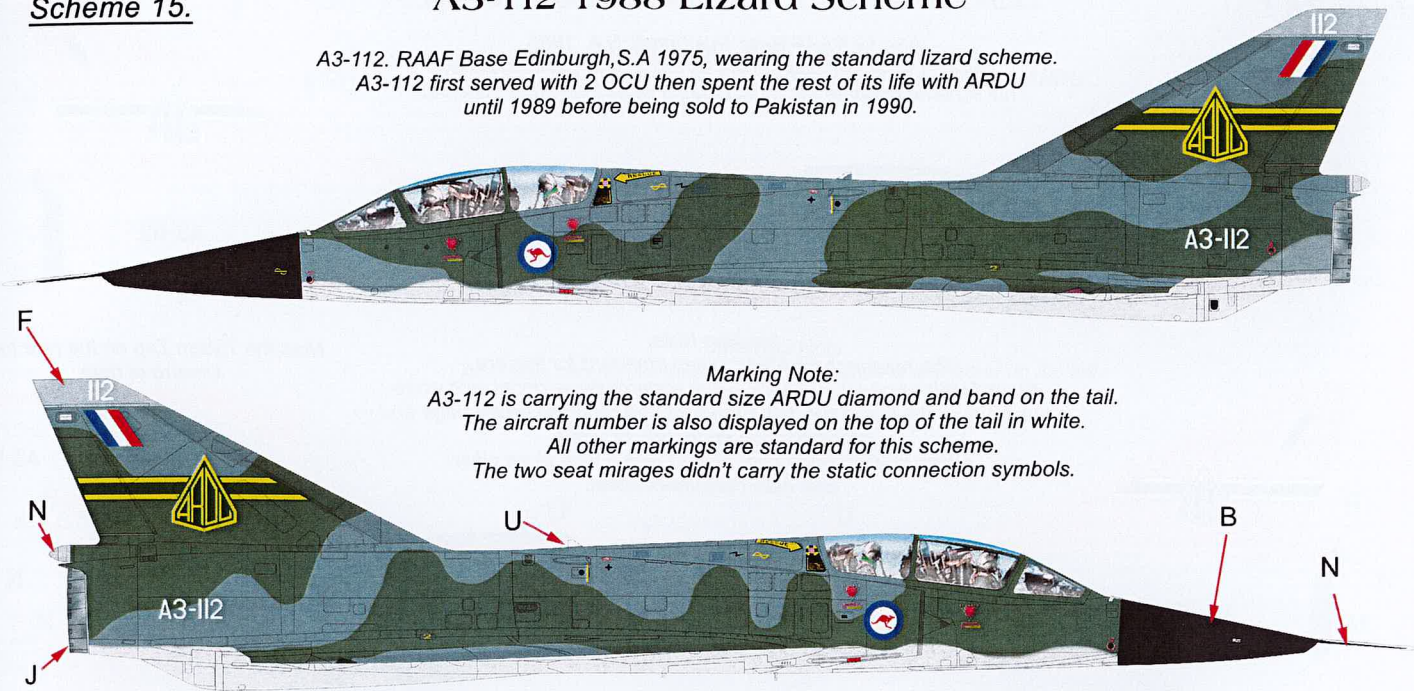

Marking Note:
A3-112 is carrying the standard size ARDU diamond and band on the tail.
The aircraft number is also displayed on the top of the tail in white.
All other markings are standard for this scheme.
The two seat mirages didn't carry the static connection symbols.

						
A BS-538c Post Office Red	B Matt Black K3/179 FS-37038	C Flat Black	E BS-298c Olive Drab	F Dark Ghost Grey FS-36320	I BS-640c Extra Dark Sea Grey	J Burnt Metal
UNDERSIDE		TACAN Antenna				
						
Q Light Gull Grey FS-36440	U BS-353 Deep Cream	N Silver				

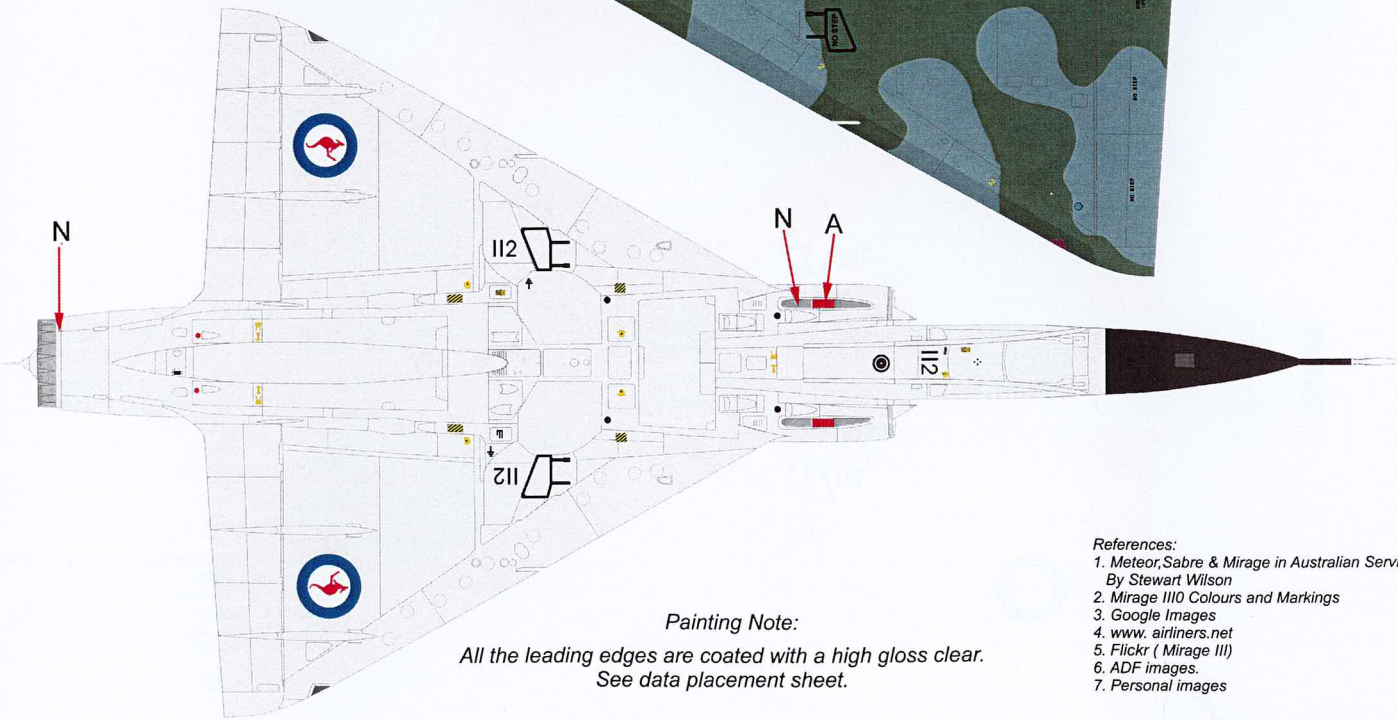
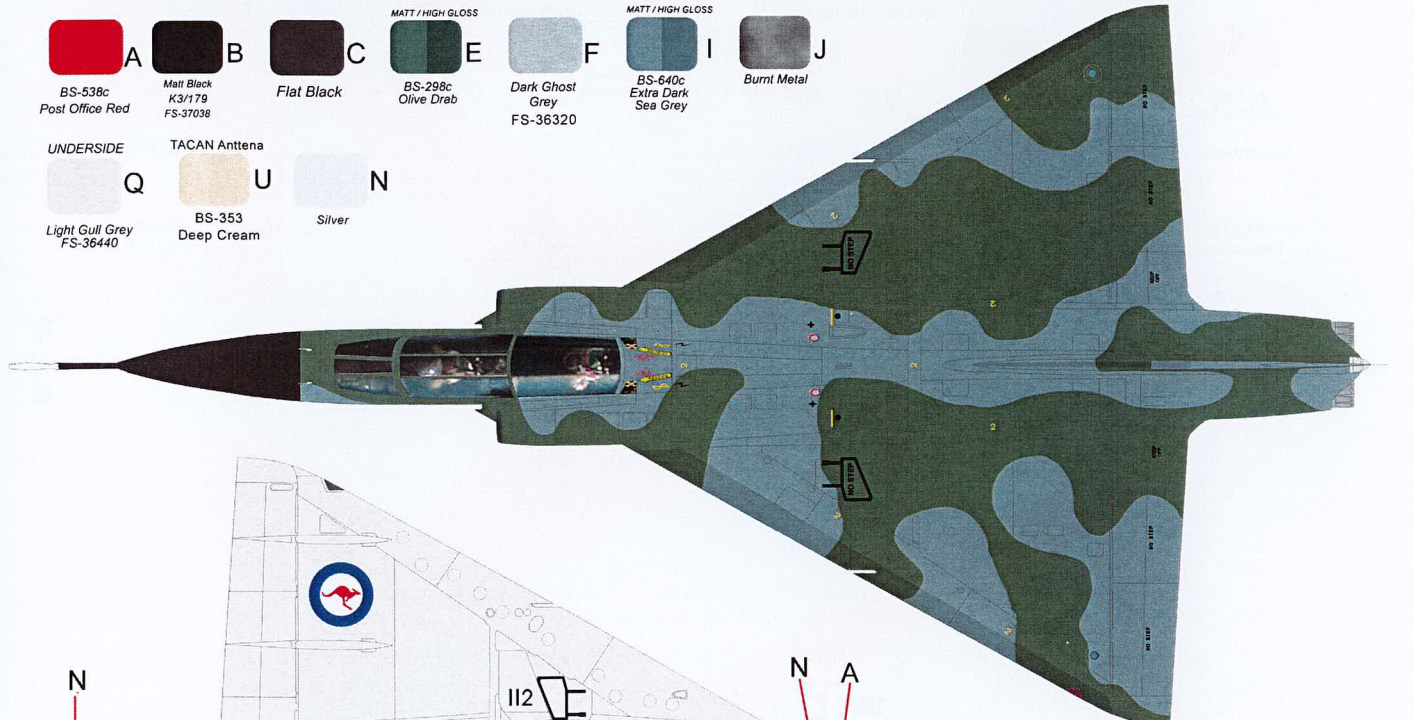

Painting Note:
All the leading edges are coated with a high gloss clear.
See data placement sheet.

- References:
1. Meteor, Sabre & Mirage in Australian Service By Stewart Wilson
 2. Mirage III Colours and Markings
 3. Google Images
 4. www. airliners.net
 5. Flickr (Mirage III)
 6. ADF images.
 7. Personal images



Scheme 16.

A3-112 1985 "Fanta Can" Scheme

A3-112 RAAF Base Edinburgh, S.A. 1985,
wearing what became known as the "Fanta Can" Scheme.
This scheme became the most popular of all the ARDU schemes.

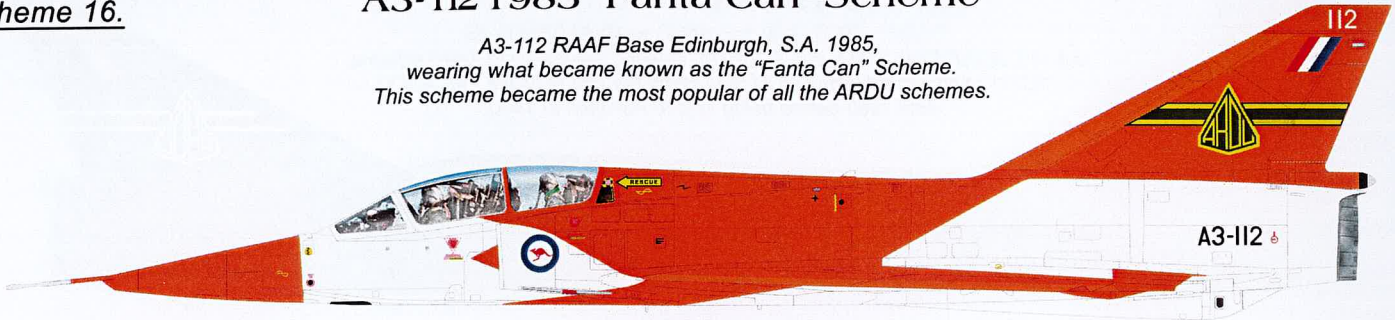

Marking Note:

The markings on A3-112 were standard for this era.
Black fuselage serial numbers, black undercarriage doors with white
numbers on the top of the tail. Standard size roundels on fuselage and
larger ones on underside of wings.
All the leading edges are coated with a high gloss clear.
See data placement sheet.

Note the 75Sqn Zap on the rear fuse.
Unsure of date.

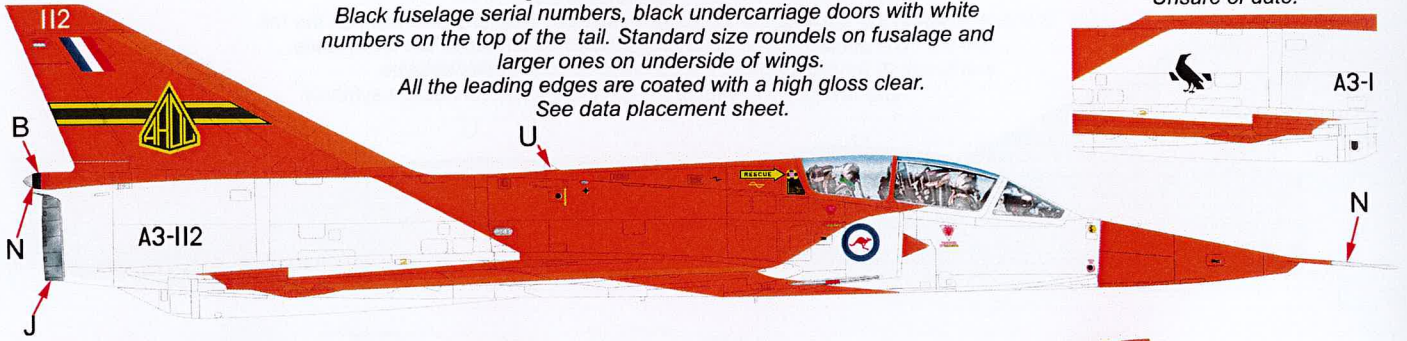
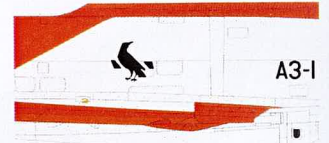

A	B	J	M	N	P
BS-538c Post Office Red	Matt Black K3/1179 FS-37038	Burnt Metal	Ultra Gloss/ Gloss BS-557 Orange	Silver	Gloss White
TACAN Antenna					
	U				
BS-353 Deep Cream					

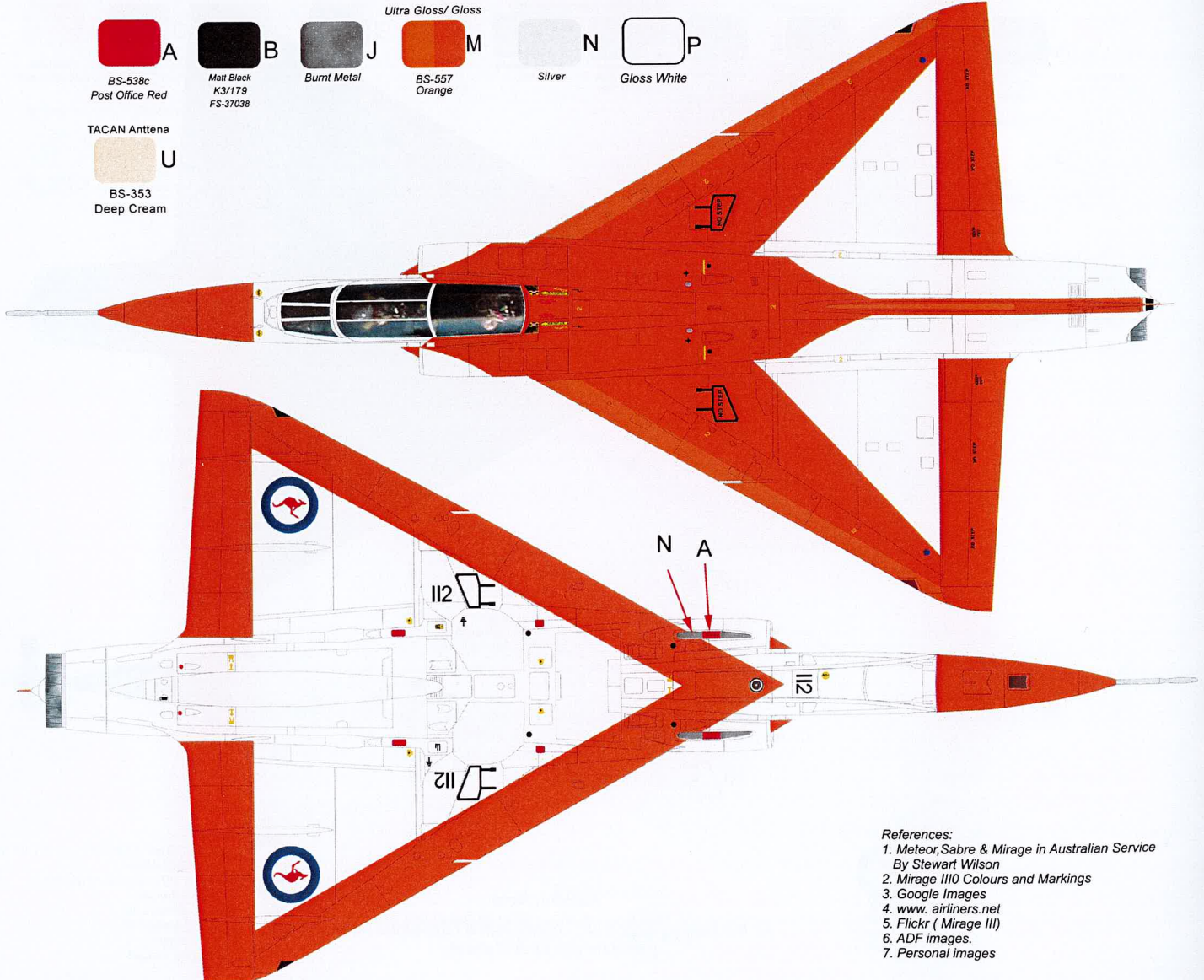

- References:
1. Meteor, Sabre & Mirage in Australian Service
By Stewart Wilson
 2. Mirage III Colours and Markings
 3. Google Images
 4. www. airliners.net
 5. Flickr (Mirage III)
 6. ADF images.
 7. Personal images



Scheme 17.

A3-115 1999 "Fanta Can" Scheme

A3-115. RAAF Base Edinburgh, S.A 1999, wearing the "Fanta Can" scheme.
A3-115 first served with 2 OCU until retirement in 1986 after which it went to ARDU
and became one of the gate guard.



Marking Note:
A3-115 is carrying the large font ARDU diamond and band on the tail.
All other markings are standard for this scheme.
All the leading edges are coated with a high gloss clear.
See data placement sheet.

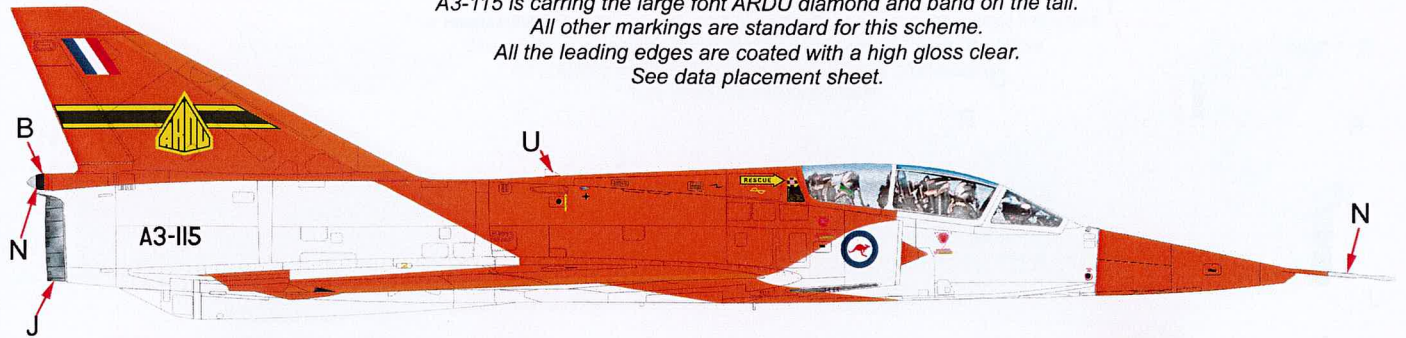

 A	 B	 J	 M	 N	 P
BS-538c Post Office Red	Matt Black K3/179 FS-37038	Burnt Metal	Ultra Gloss/ Gloss BS-557 Orange	Silver	Gloss White
TACAN Antenna					
 U					
BS-353 Deep Cream					

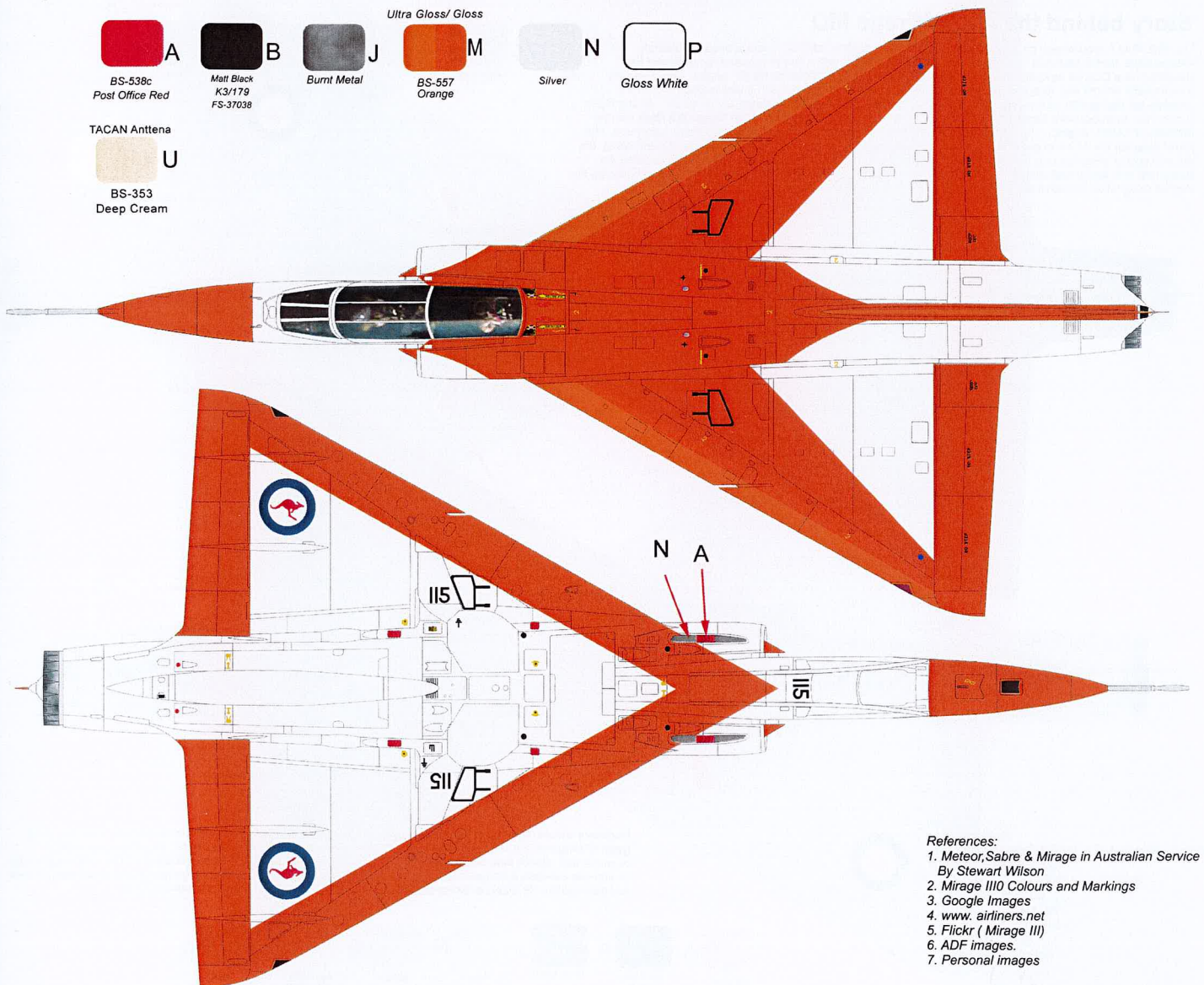

- References:
1. Meteor, Sabre & Mirage in Australian Service
By Stewart Wilson
 2. Mirage III/0 Colours and Markings
 3. Google Images
 4. www.airliners.net
 5. Flickr (Mirage III)
 6. ADF images.
 7. Personal images



Avon Mirage III O

Scheme 18.

“City of Hobart”

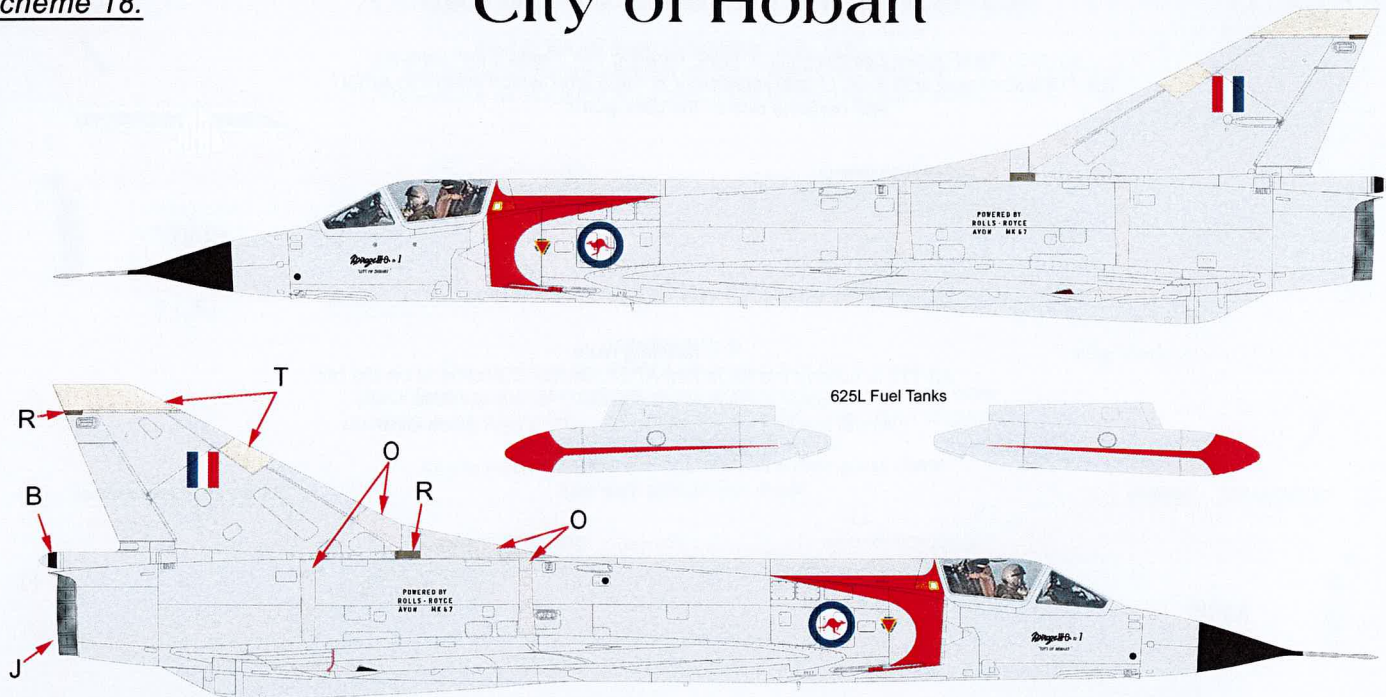

Story behind the Avon Mirage III O

The 1960 RAAF requirement for a supersonic interceptor to replace the CAC Sabre prompted Generale Aeronautique Marcel Dassault (GAMD) to modify their Mirage IIIA with a longer fuselage for additional fuel, installation of a Doppler navigation radar and fitting a Rolls Royce RB146 Avon Mk 67 engine. This company demonstrator aircraft was designated the Mirage III O and named "City of Hobart". It was marked with RAAF roundels but this aircraft was never part of the RAAF and therefore was not allocated an "A" serial. 45 test flights showed the Avon powered Mirage to be superior at high altitude to a similarly modified Mirage IIIA fitted with the SNEMCA ATAR9C engine. The lighter and cheaper ATAR9C appealed to more potential Mirage customers. The RAAF selected the ATAR to power its Mirages, thereby sharing development costs with France and not taking the risk and cost of being the only operator of a uniquely powered fighter. The ATAR powered Mirage became the Mirage IIIE and with modifications required for RAAF service was designated the Mirage IIIO, thereby continuing the original designation allocated to the Avon Mirage.

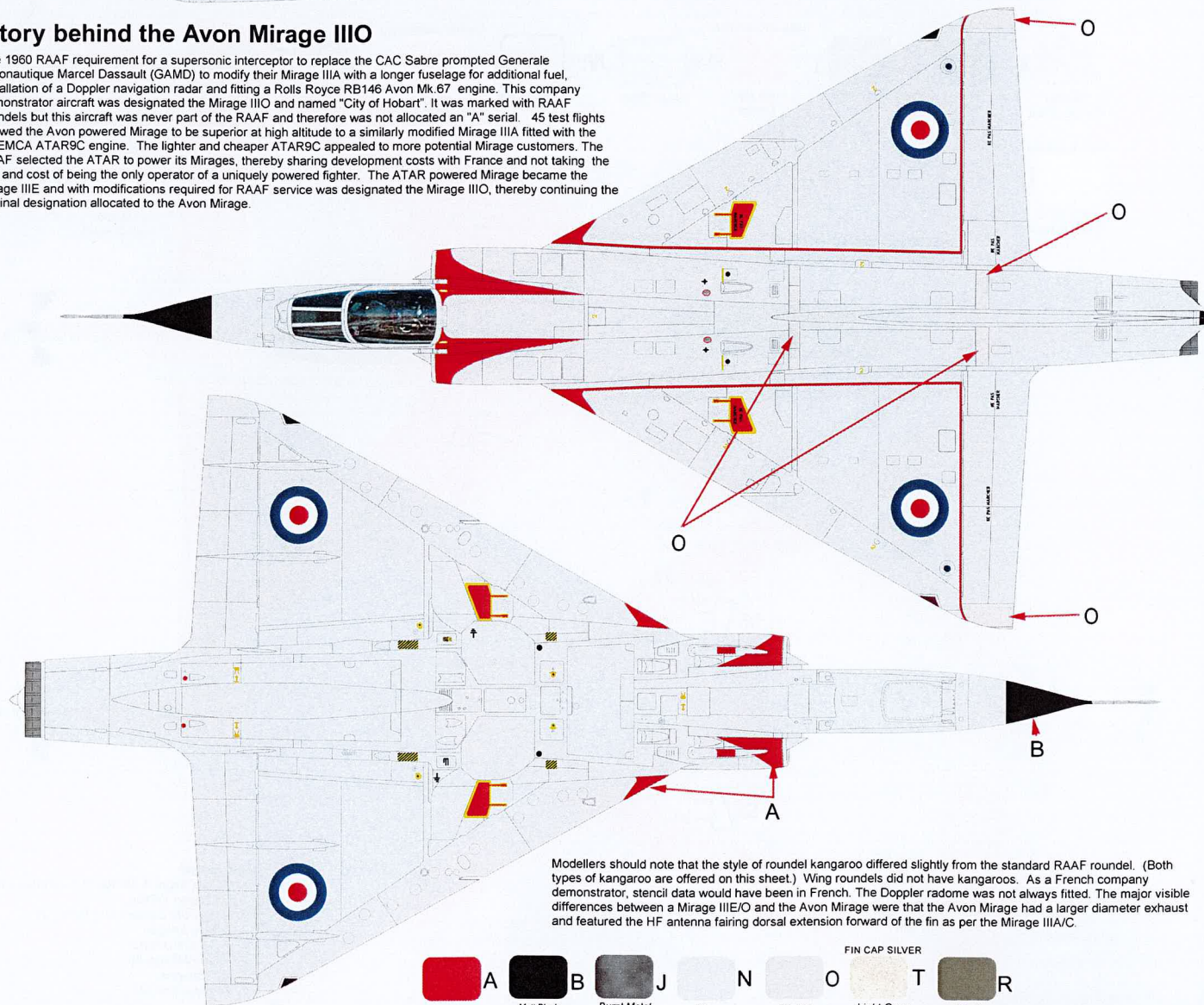

Modellers should note that the style of roundel kangaroo differed slightly from the standard RAAF roundel. (Both types of kangaroo are offered on this sheet.) Wing roundels did not have kangaroos. As a French company demonstrator, stencil data would have been in French. The Doppler radome was not always fitted. The major visible differences between a Mirage IIIE/O and the Avon Mirage were that the Avon Mirage had a larger diameter exhaust and featured the HF antenna fairing dorsal extension forward of the fin as per the Mirage IIIA/C.

A	B	J	N	O	T	R
BS-538c Post Office Red	Matt Black F3/179 FS-37038	Burnt Metal	Silver	BS-627 Light Grey	Light Grey FS-16492	FIN CAP SILVER Steel

PRINTED AND DESIGNED BY:
ROYNTH GRAPHICS AUSTRALIA
AUSTRALIAN MADE AND OWNED

RDS-083 RAAF "City of Hobart" / ARDU Mirage III O/D History



Scheme 19.

A3-2 1970 Lizard + Scheme

A3-2. Avalon, Vic, 1970, wearing the Image alignment Crosses in the Lizard scheme.
A3-2 served most of its life with ARDU. This was just one of many paint schemes that this aircraft would adorn in its service life with the RAAF.

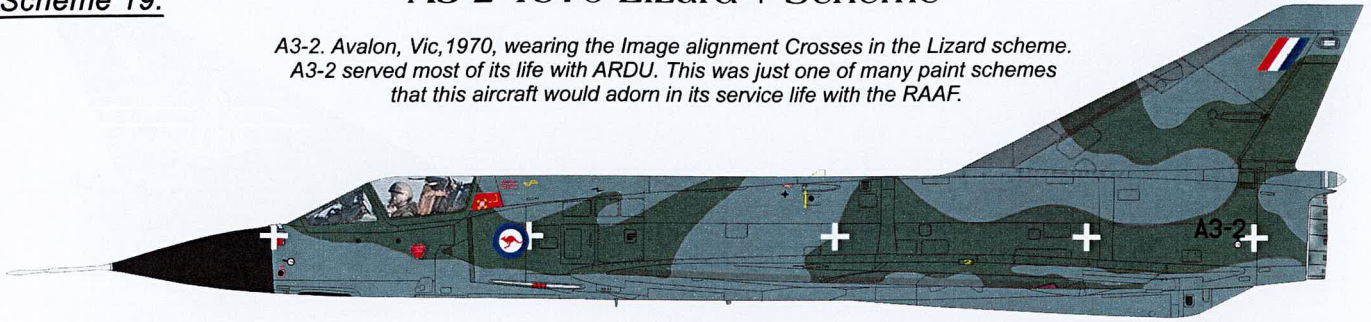

Marking Note:

This aircraft scheme didn't carry any rescue arrows.
The rescue break glass panels are in red with large ejection seat triangles.
The static connection symbol is in red instead of usual yellow.
All leading edges are coated with a high gloss clear.
See data placement sheet.

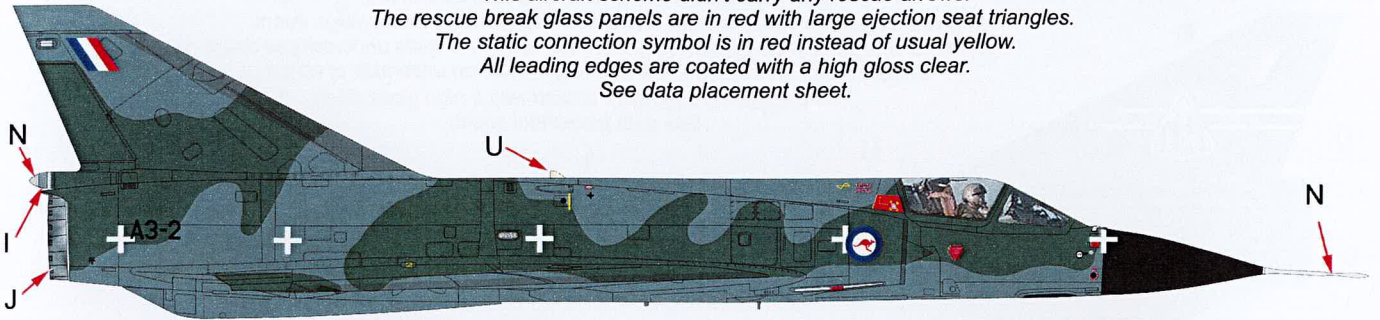

A	B	E	I	J	N
BS-538c Post Office Red	Matt Black K3/179 FS-37038	BS-298c Olive Drab	BS-640c Extra Dark Sea Grey	Burnt Metal	Silver

TACAN Antenna

	U
BS-353 Deep Cream	

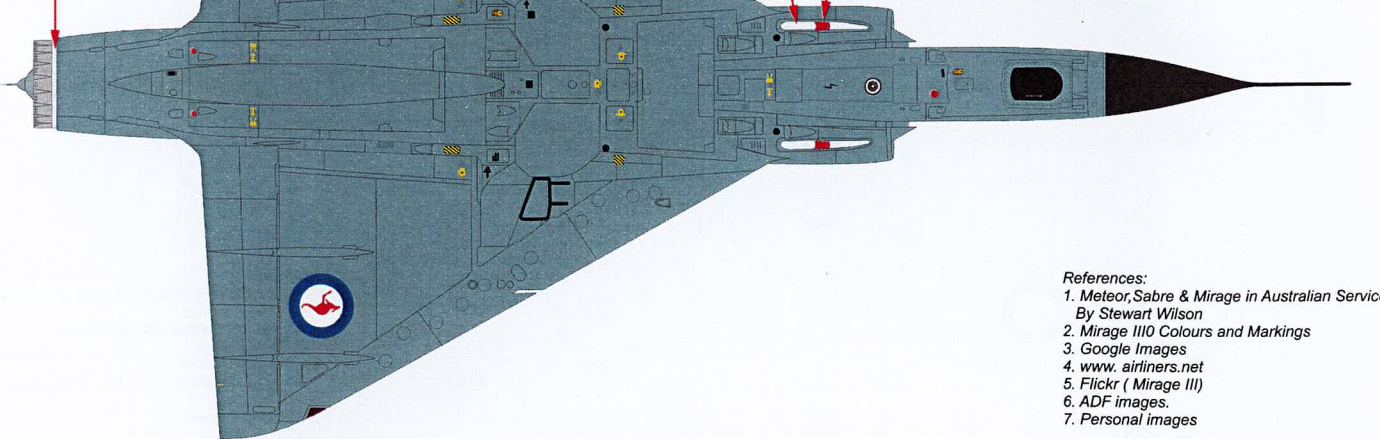
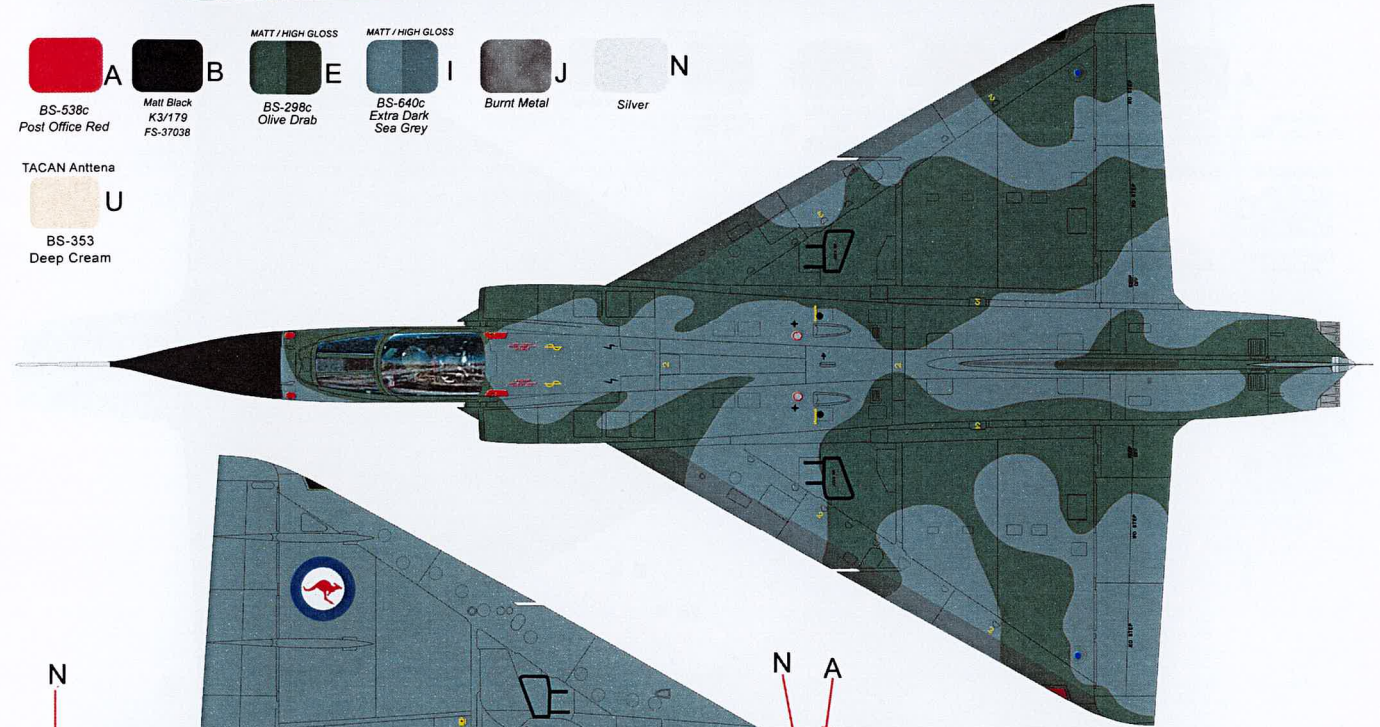

- References:
1. Meteor, Sabre & Mirage in Australian Service By Stewart Wilson
 2. Mirage III/O Colours and Markings
 3. Google Images
 4. www.airliners.net
 5. Flickr (Mirage III)
 6. ADF images.
 7. Personal images



Scheme 20.

A3-76 "Lizard" Scheme 2

A3-76 RAAF Base Edinburgh, S.A.
wearing the standard ARDU diamond and band tail
with a yellow and black camera nose with no shroud.

Note:
The 10 Sqn Zap on the nose

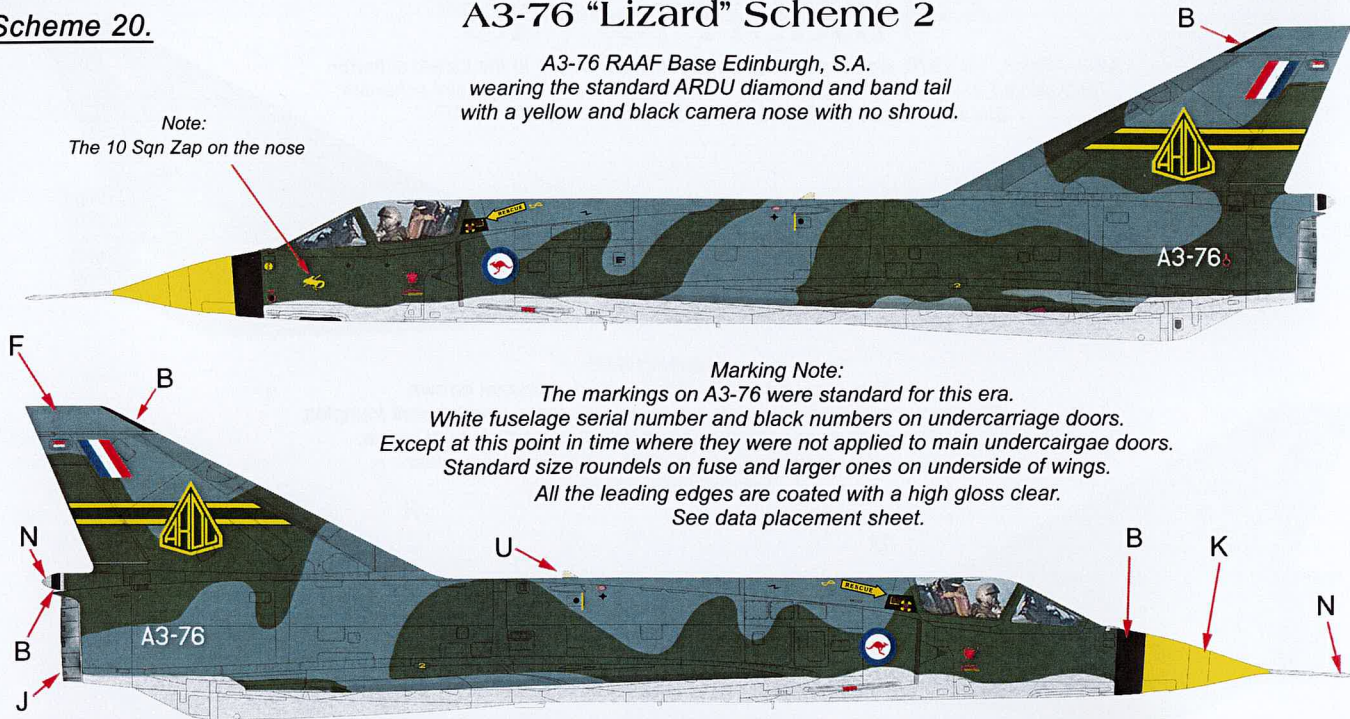

Marking Note:
The markings on A3-76 were standard for this era.
White fuselage serial number and black numbers on undercarriage doors.
Except at this point in time where they were not applied to main undercarriage doors.
Standard size roundels on fuse and larger ones on underside of wings.
All the leading edges are coated with a high gloss clear.
See data placement sheet.

 A BS-538c Post Office Red	 B Matt Black K3/179 FS-37038	 C Flat Black	 E BS-298c Olive Drab	 F Dark Ghost Grey FS-36320	 I BS-640c Extra Dark Sea Grey	 J Burnt Metal
UNDERSIDE						
 Q Light Gull Grey FS-36440	 U BS-353 Deep Cream	 N Silver	 K BS-356 Golden Yellow			

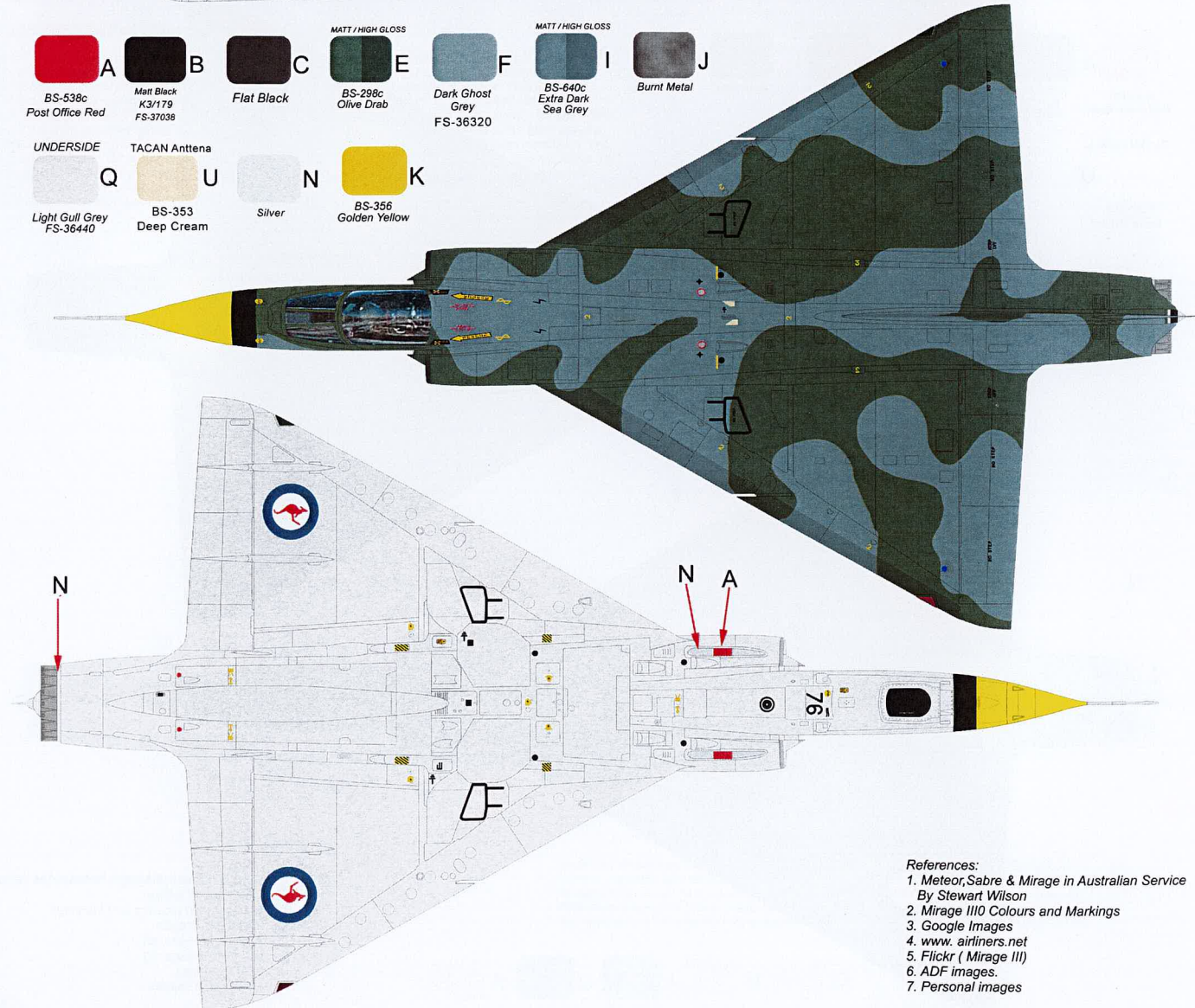

References:
1. Meteor, Sabre & Mirage in Australian Service
By Stewart Wilson
2. Mirage III Colours and Markings
3. Google Images
4. www. airliners.net
5. Flickr (Mirage III)
6. ADF Images.
7. Personal images



Mirage III/O

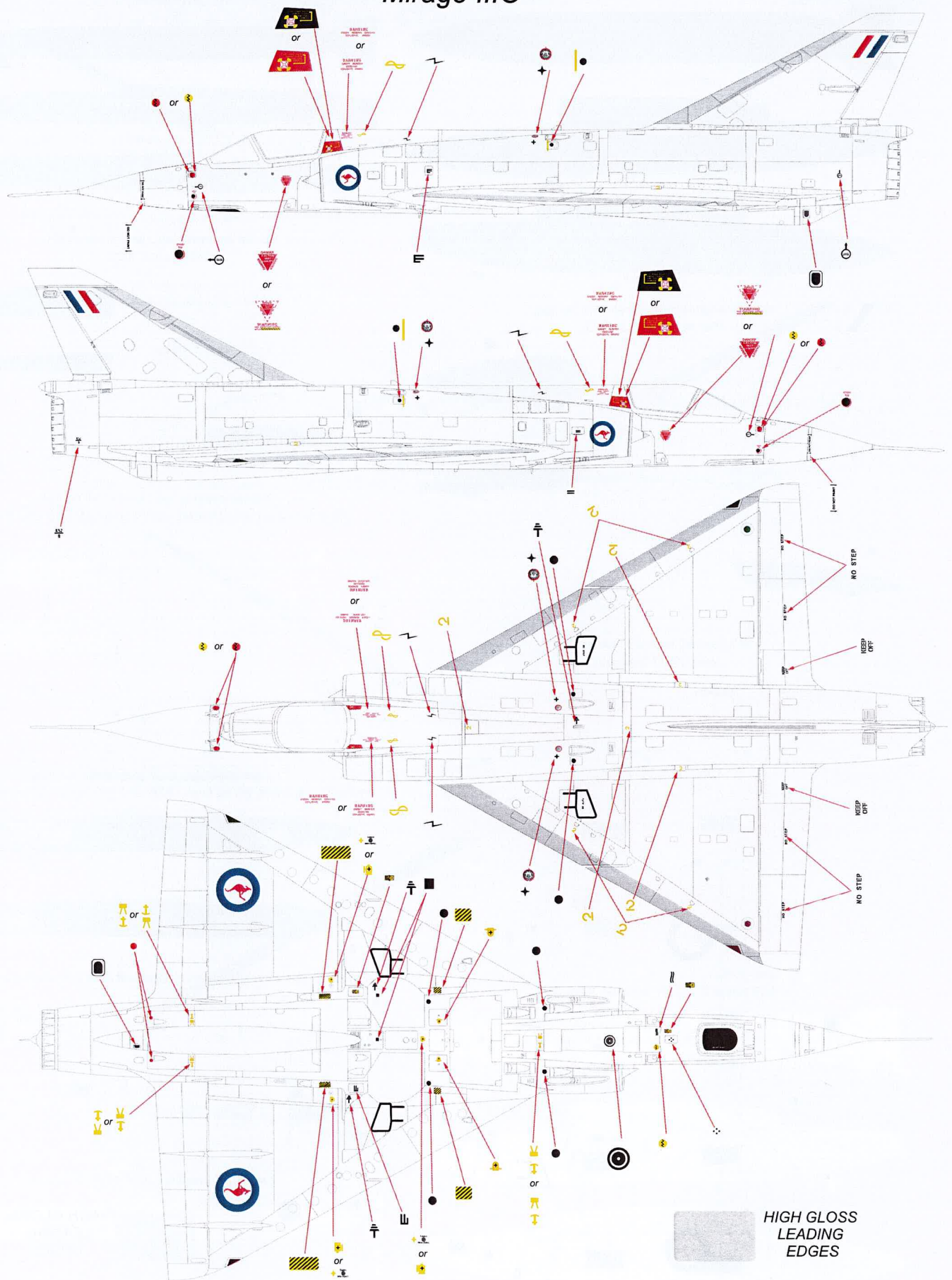

Mirage IIID

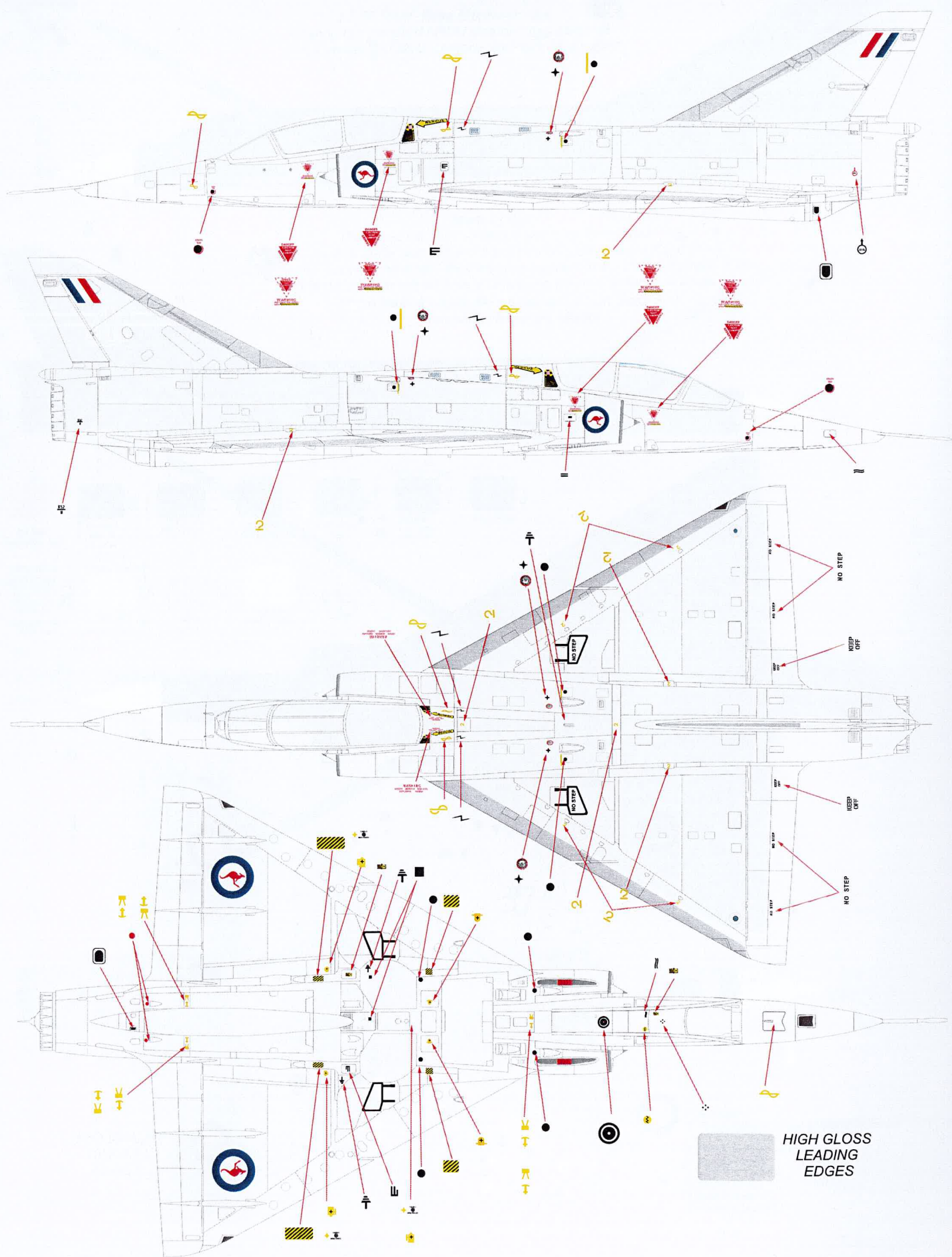

RAAF Mirage III/O/D Fuel Tanks and Camera Pods

Paint schemes



500L Speed Tank
Israeli Type

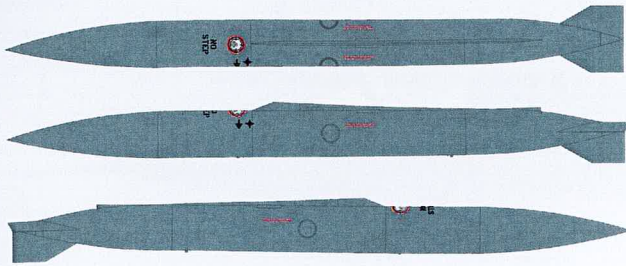

Use on the first Lizard scheme aircraft

1700L Long Range Tank

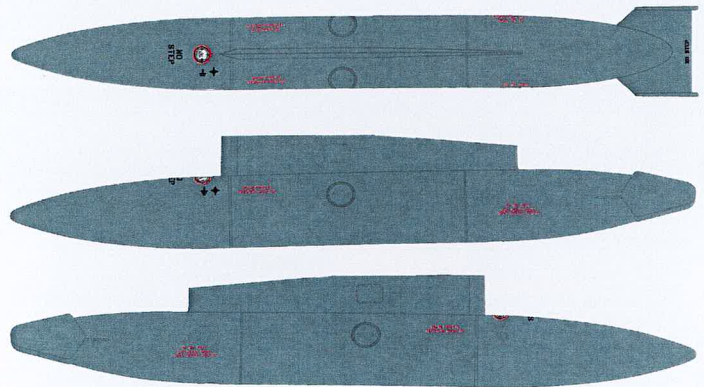

Use on the 3 tone Lizard scheme aircraft
500L Speed Tank

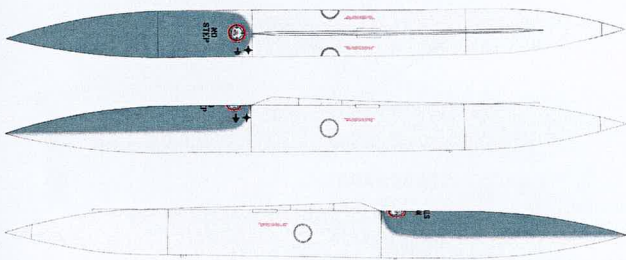

Use on the 3 tone Lizard scheme aircraft
1700L Long Range Tank

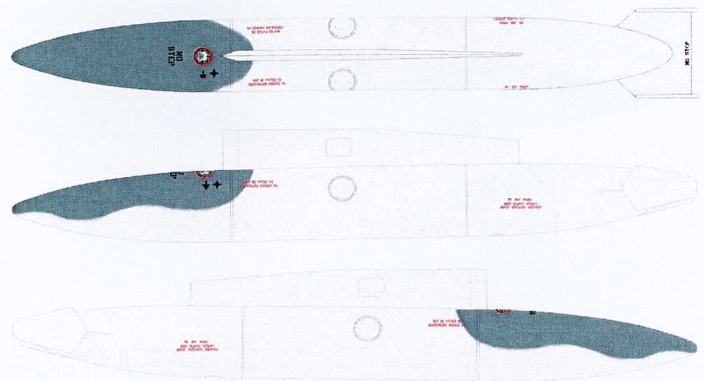

used on the "Fanta Can" scheme aircraft
Original "Fanta Can" Scheme Mirage carried just white speed tanks.

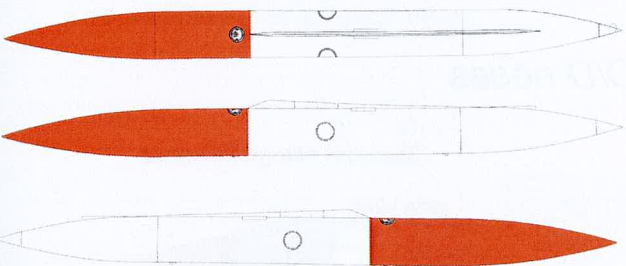

"Fanta Can" Scheme Camera Pod.
Converted 1700L Tank

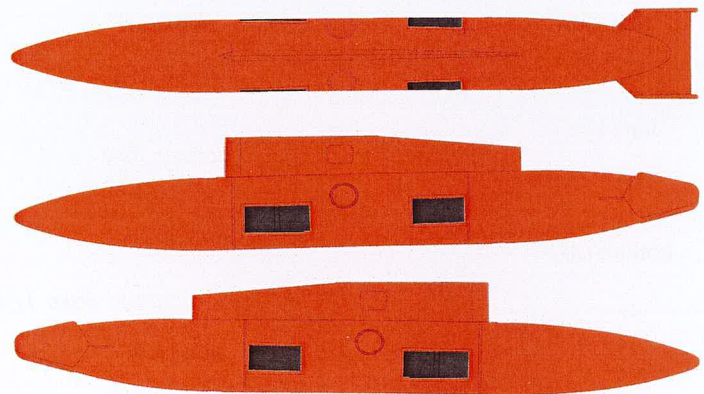

"Lizard" scheme 500L tank and Bomb Rack
This one carried the three thin line ARDU band on the outside of the tank.

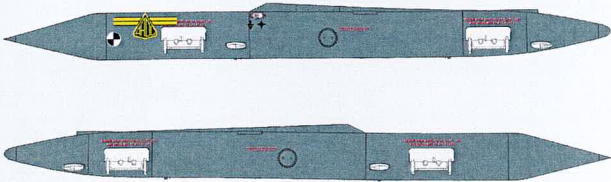

This one carried the two thick line ARDU band on the outside of the tank.

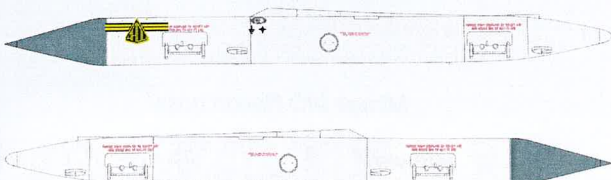

"Aussie" Scheme Mirage Camera Pod

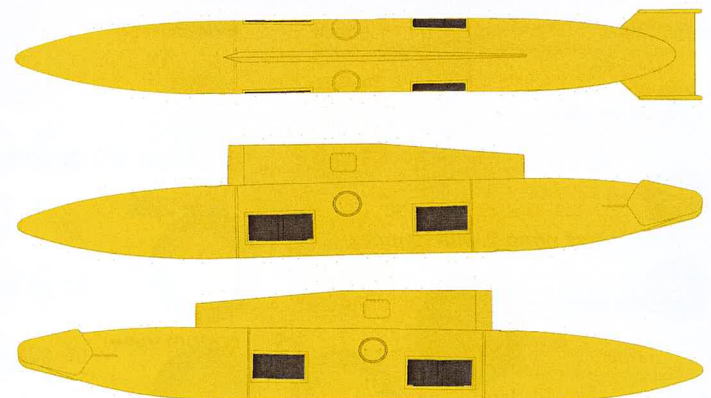

"Aussie" Scheme 500L Tank and bomb rack

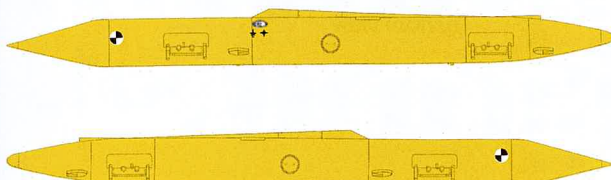



RAAF Mirage III O/D Fuel Tanks and Camera Pods

Data placement sheet

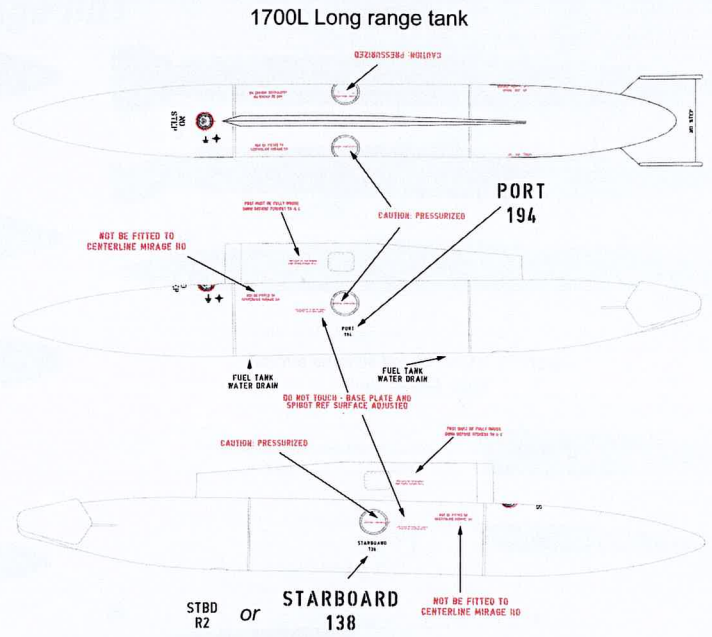
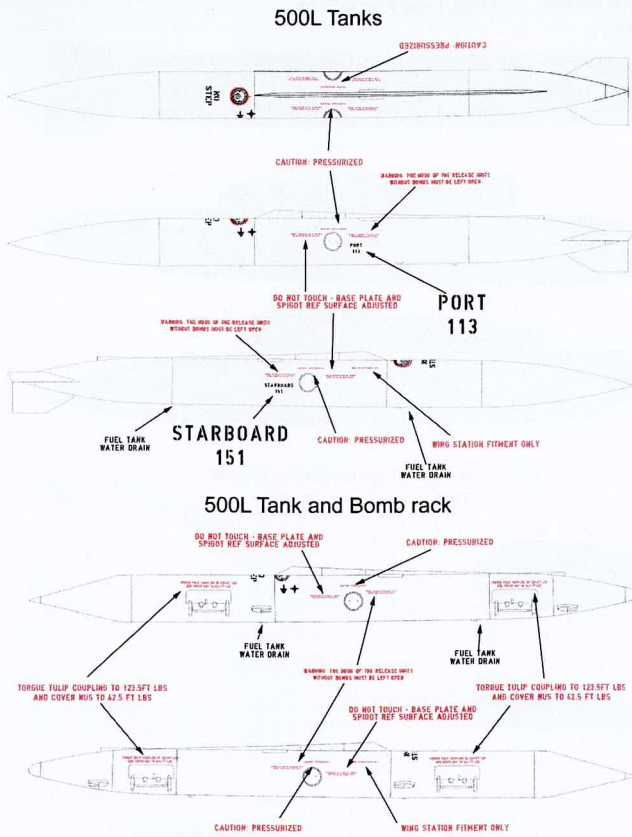

Note:
Not all fuel tanks have the same marking layout as shown here.
some tanks may not have any markings on them at all.
If possible refer back to reference photos of the one that you are building.

RAAF Mirage III O/D noses

Standard Mirage III O nose

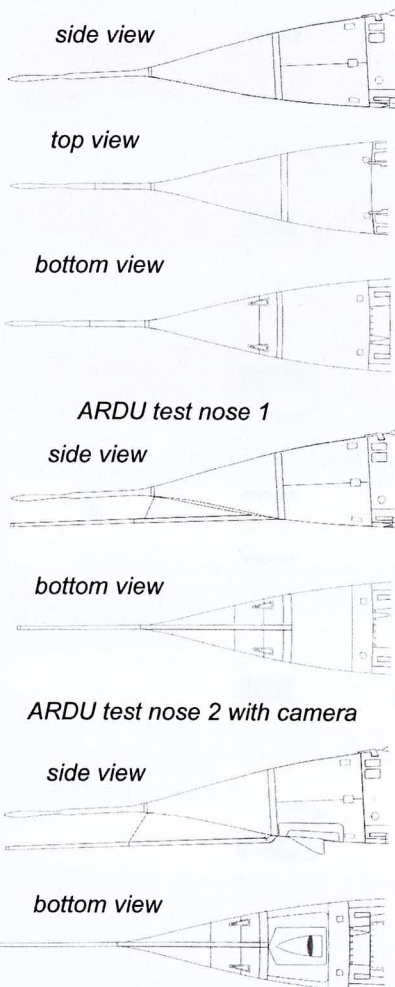

Camera nose Type 1

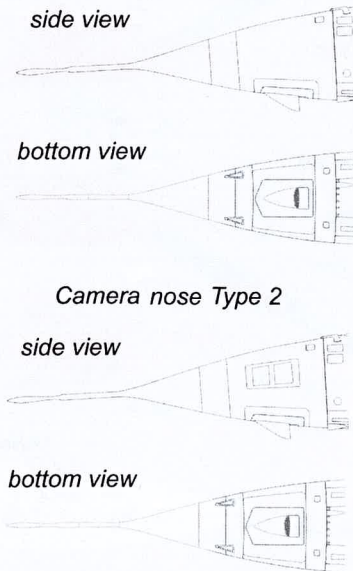

Standard Mirage III D nose

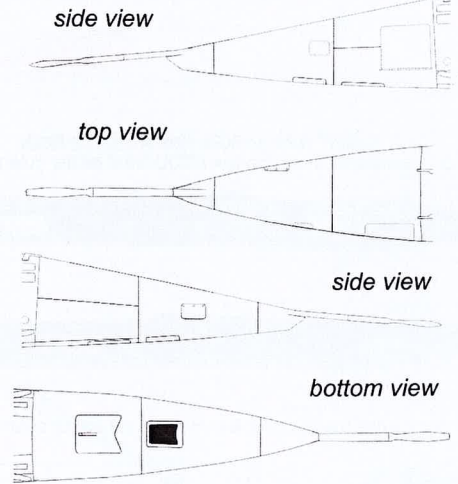

ARDU test nose 1

Camera nose Type 2

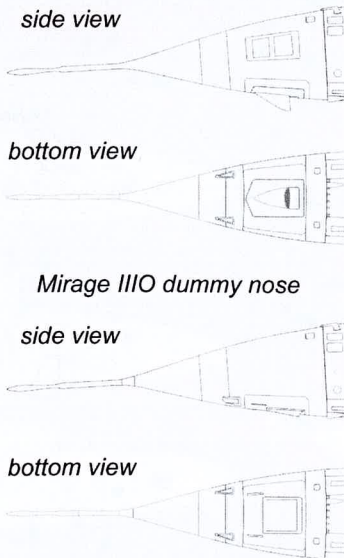

Mirage III O Recon nose

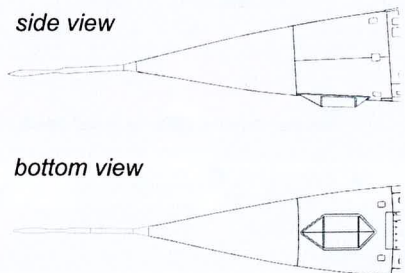

ARDU test nose 2 with camera

Mirage III O dummy nose

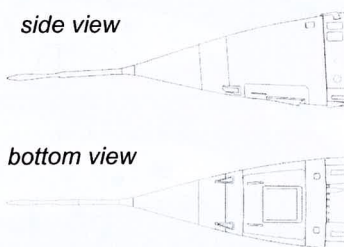

RAAF Mirage IIIO/D Paint Masks

for Kinetic Kit

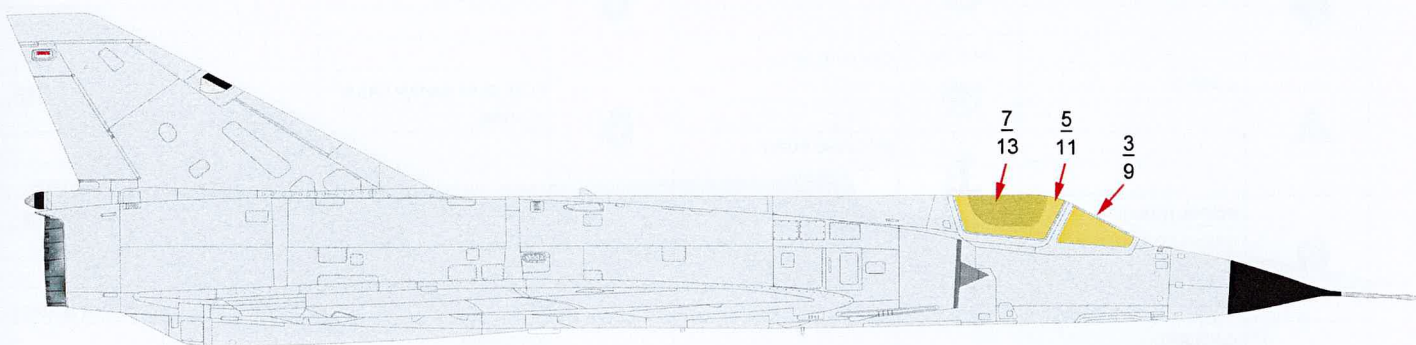

The main Canopy Masks are designed so that they overlap each other.

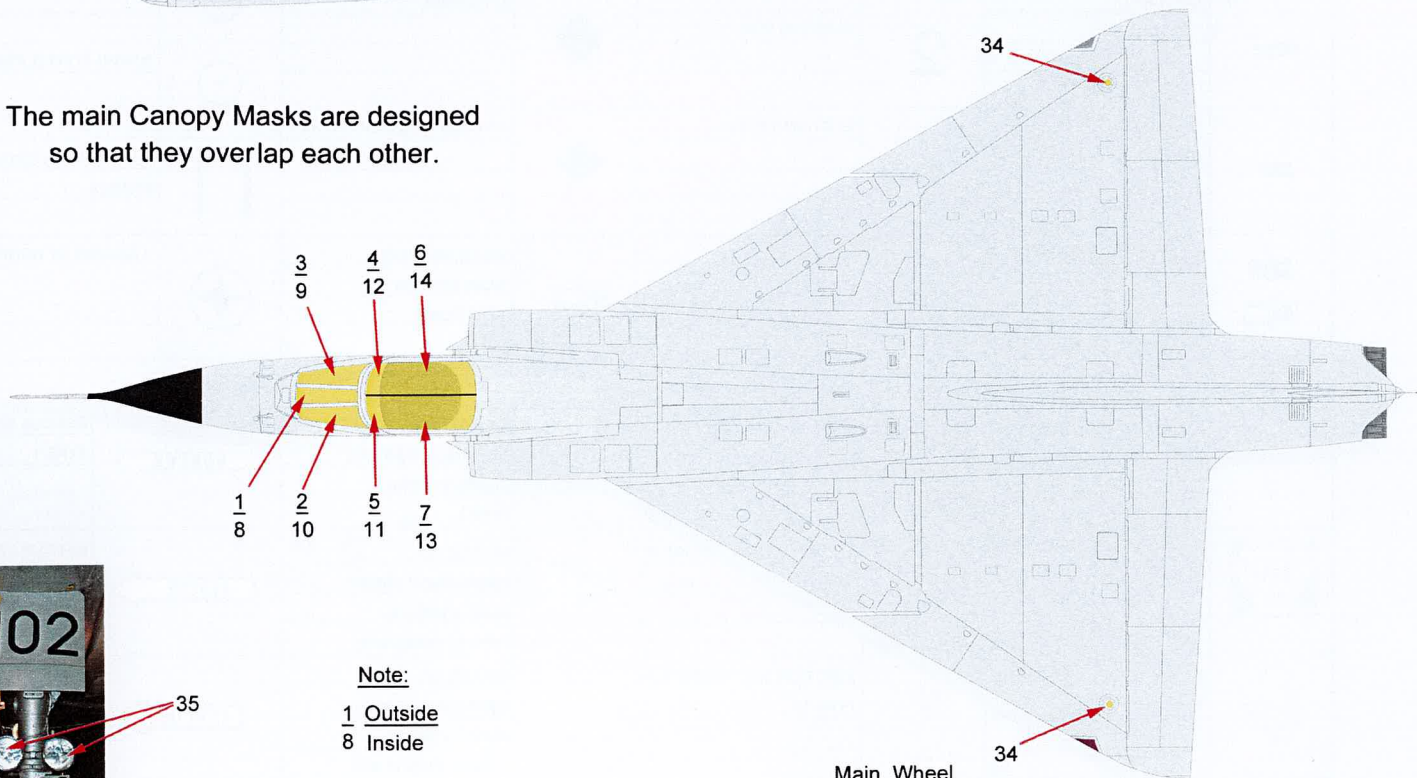





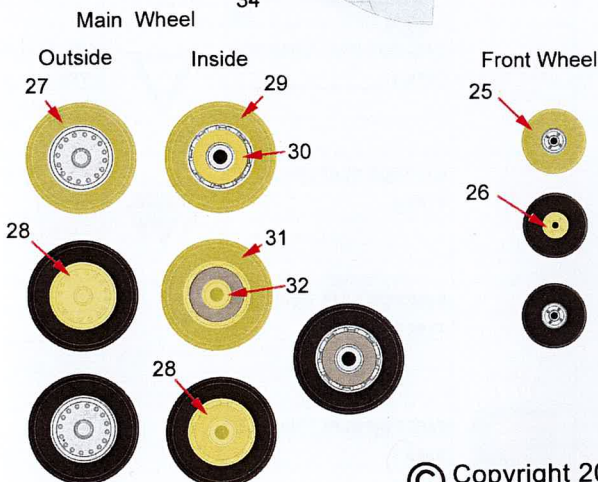
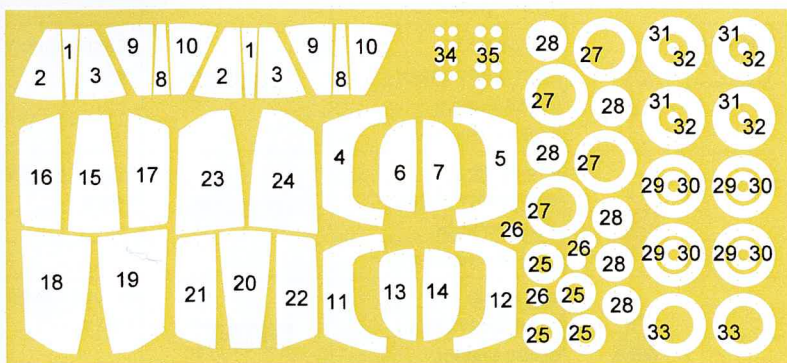

























































Note:

1 Outside
8 Inside



STANDARD NATO CODES AND MARKING IDENTIFICATION SHEET USED BY THE ROYAL AUSTRALIAN AIR FORCE

	REFUELING POINT		INSPECTION OF BATTERY		EXTERNAL ELECTRICAL CONNECTION		DRINKING WATER
	ENGINE LUBRICATING OIL NATO CODE No O-148		AIR CONDITIONING		INSPECTION OF ELECTRONIC INSTALLATION		FLIGHT DATA RECORDER
	HYDRAULIC FLUID NATO CODE No H-515		TOWING POINT		INSPECTION OF FUEL FILTER		TOILET SERVICING
	DEICING	 <small>CRASH TOW</small>	CRASH TOW		FUEL TANK WATER DRAIN (LATER)		PNEUMATIC STARTER CONNECTION
	INSPECTION OF STATIC CONNECTION		MOORING POINT	 <small>TANKS DRAINAGE</small>	FUEL TANK DRAIN (EARLY)		PNEUMATIC SYSTEM
	COOLANT		HOISTING POINT		NITROGEN		STATIC PORT (EARLY)
	OXYGEN (BREATHING)		EARTHING POINT		FIRE EXTINGUISHING POINT		STATIC PORT (LATER)
	HYDRAULIC SYSTEM TEST		CABIN PRESSURE TEST POINT		INSERTING FLUID TANK SYSTEM TEST POINT		LIFTING AREA EXTERNAL STORES
	HYDRAULIC SYSTEM TEST		CABIN PRESSURE TEST POINT		INSERTING FLUID TANK SYSTEM TEST POINT		LOCKING OF DROP TANK

	EJECTION SEAT TRIANGLE TYPE 1		EJECTION SEAT TRIANGLE TYPE 8 (Mirage IIIs & F/A-18s)		MIRAGE IIIO EMERGENCY BREAK GLASS SYMBOL TYPE 1		RESCUE ARROW TYPE 1
	EJECTION SEAT TRIANGLE TYPE 2		EJECTION SEAT TRIANGLE TYPE 9		MIRAGE IIIO EMERGENCY BREAK GLASS SYMBOL TYPE 2 (White text)		RESCUE ARROW TYPE 2
	EJECTION SEAT TRIANGLE TYPE 3		EJECTION SEAT TRIANGLE TYPE 10		MIRAGE IIIO EMERGENCY BREAK GLASS SYMBOL TYPE 3 (Yellow text)		RESCUE ARROW TYPE 3
	EJECTION SEAT TRIANGLE TYPE 4		EJECTION SEAT TRIANGLE TYPE 11 (F/A-18s)		MIRAGE IIIO EMERGENCY BREAK GLASS SYMBOL TYPE 4 (Yellow text)		RESCUE ARROW TYPE 4
	EJECTION SEAT TRIANGLE TYPE 5		EJECTION SEAT TRIANGLE TYPE 12 (F-111s)		MIRAGE IIID EMERGENCY BREAK GLASS SYMBOL TYPE 1A (Red text)		RESCUE ARROW TYPE 5
	EJECTION SEAT TRIANGLE TYPE 6				MIRAGE IIID EMERGENCY BREAK GLASS SYMBOL TYPE 3A (yellow text)		RESCUE ARROW TYPE 6
	EJECTION SEAT TRIANGLE TYPE 7				MIRAGE IIID EMERGENCY BREAK GLASS SYMBOL TYPE 4A (yellow text)		RESCUE ARROW TYPE 7

RAAF Mirage III O/D Paint Masks

for Kinetic Kit

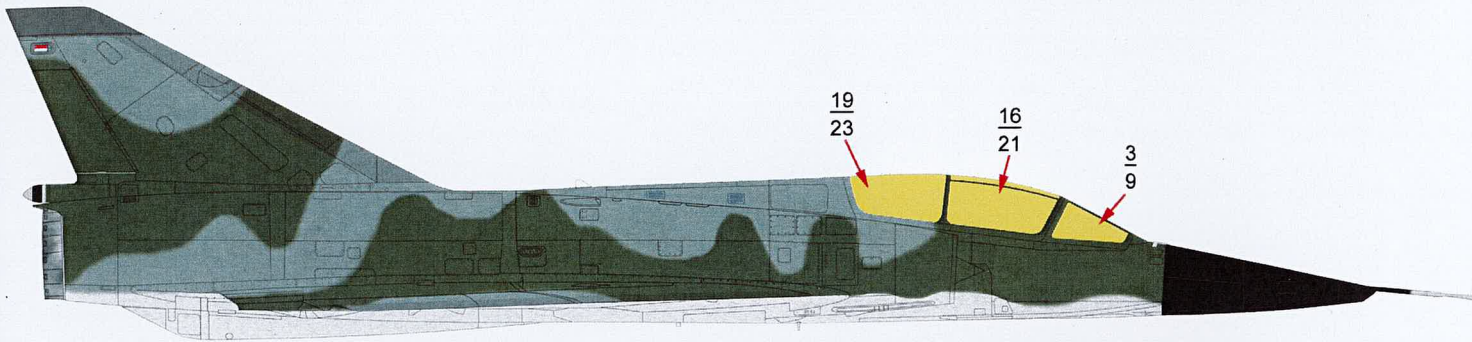

The main Canopy Masks are designed so that they overlap each other.

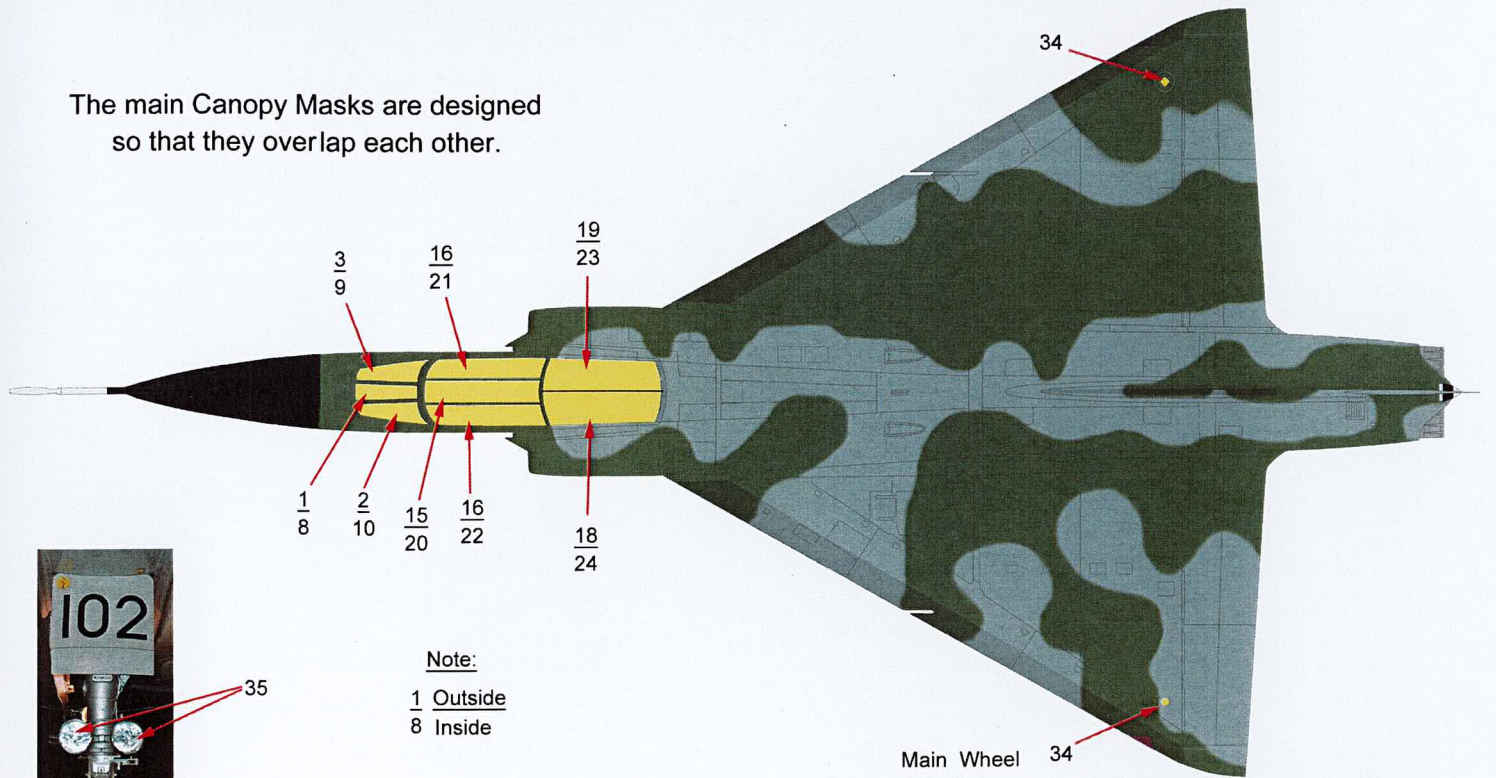

Note:
1 Outside
8 Inside

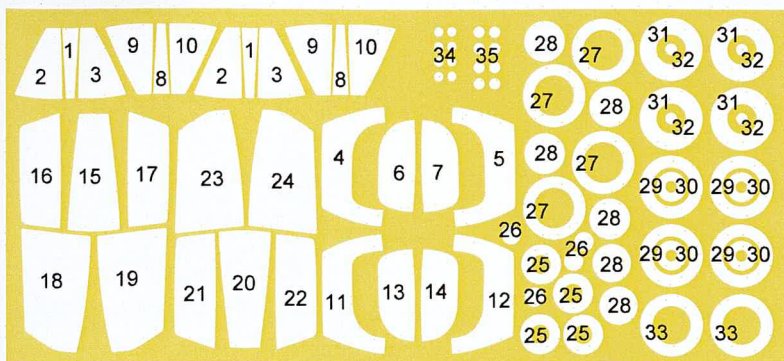
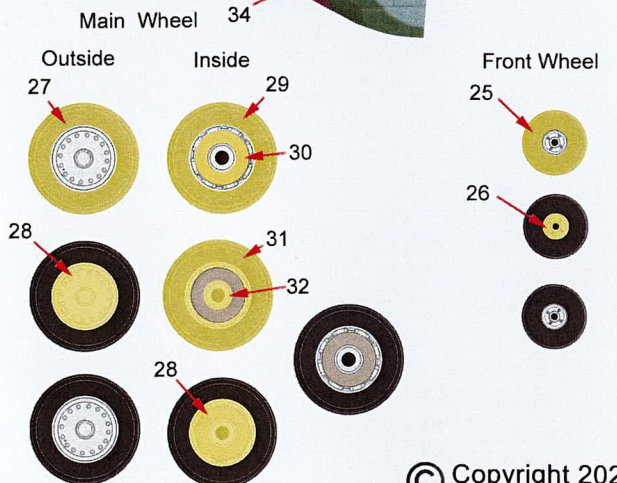

RAAF "City of Hobart" | ARDU Mirage III/OID History



A A 12
 A3-2 A3-2 A3-12 A3-12 1212
 A3-2 A3-2 2 A3-112 A3-112
 A3-16 A3-16 161616 112112
 A3-53 A3-53 53535353
 A3-76 A3-76 76767653
 A3-101 A3-101101101101115
 A3-111 A3-11111111111115115

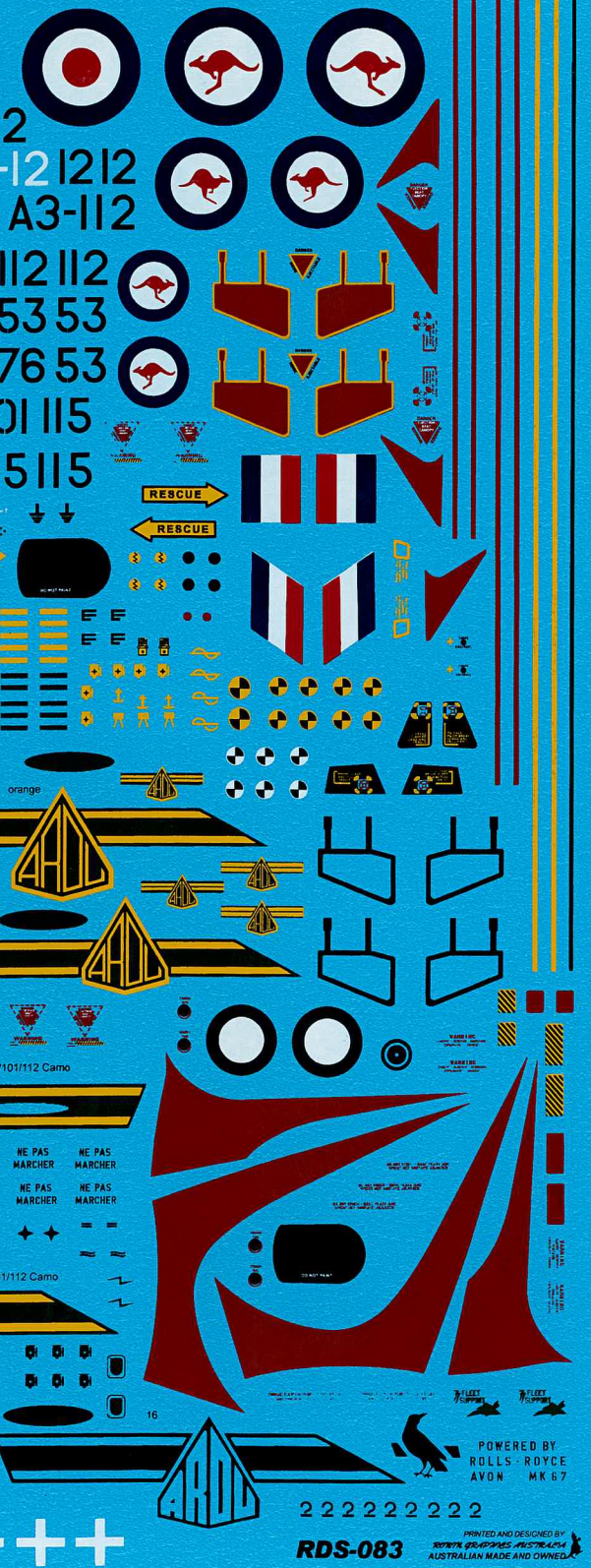
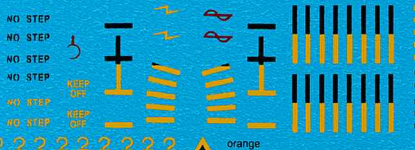

NO STEP
 NO STEP
 NO STEP
 NO STEP
 NO STEP

KEEP OFF
 KEEP OFF
 KEEP OFF
 KEEP OFF

POWERED BY
 ROLLS ROYCE
 AVON MK 67

115 115

16

orange
 orange

12/76/101/112 Camo

NE PAS MARCHER
 NE PAS MARCHER
 NE PAS MARCHER
 NE PAS MARCHER

12/76/101/112 Camo

16

RESCUE

RESCUE

CITY OF HOBART

CITY OF HOBART

CITY OF HOBART

CITY OF HOBART

CITY OF HOBART

CITY OF HOBART

CITY OF HOBART

CITY OF HOBART

CITY OF HOBART

CITY OF HOBART

CITY OF HOBART

CITY OF HOBART

CITY OF HOBART

CITY OF HOBART

CITY OF HOBART

CITY OF HOBART

CITY OF HOBART

CITY OF HOBART

CITY OF HOBART

2 2 2 2 2 2 2 2 2 2

RDS-083

PRINTED AND DESIGNED BY
 ROLLS ROYCE AUSTRALIA
 AUSTRALIAN MADE AND OWNED

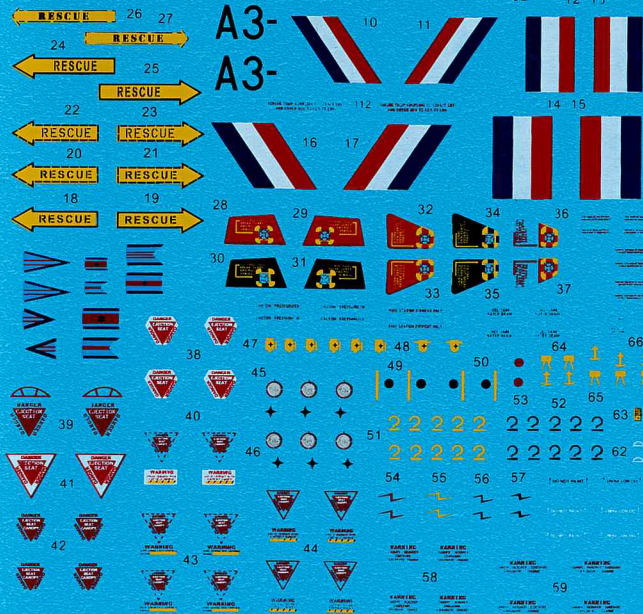
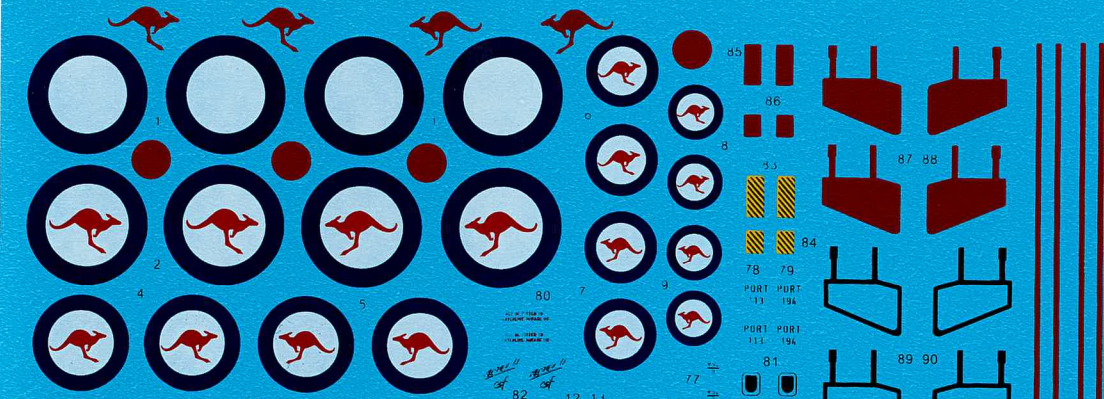

11223344556677889900
11223344556677889900
11223344556677889900
11223344556677889900
11223344556677889900
11223344556677889900
11223344556677889900
11223344556677889900
11223344556677889900
11223344556677889900
11223344556677889900



