

CUT

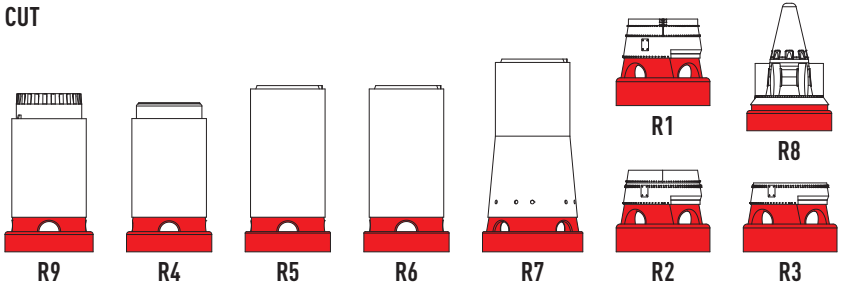

1 DRILL THROUGH HOLES D: 0.3 MM

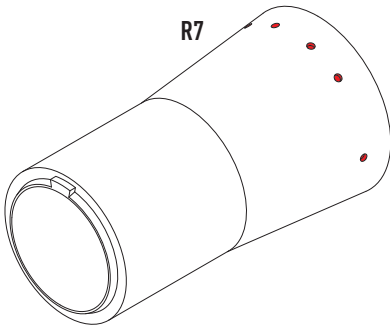

2

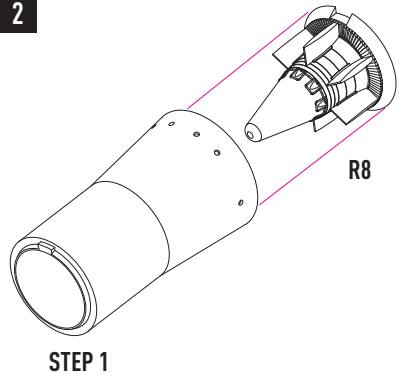

3 USE WIRE D: 0.3 MM, A = L: 3.3 MM, B = L: 2.8 MM

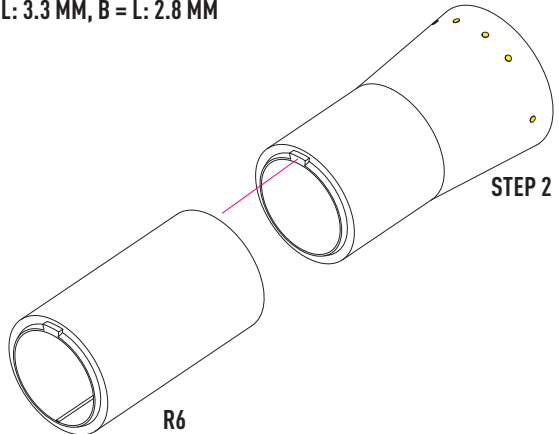
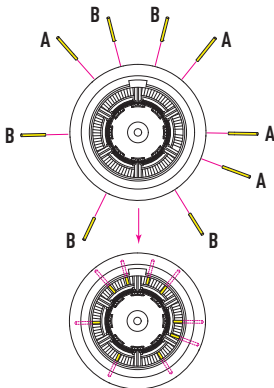

4

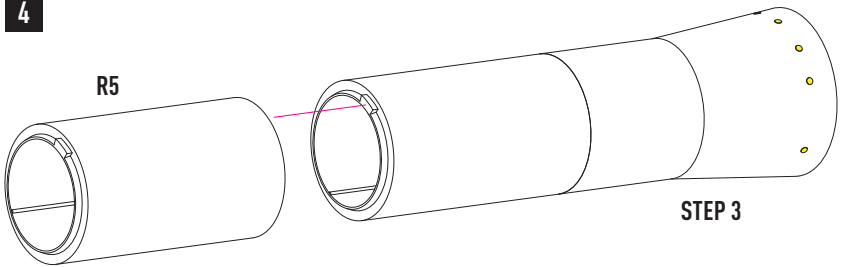

5

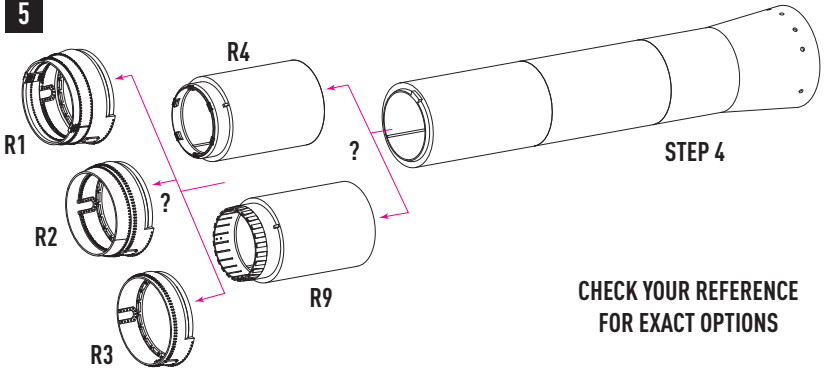

6

**PART FROM THE KIT A1.
SYMMETRICALLY REPEAT ON THE DETAIL A2**

