

⚠ WARNING: READ THIS BEFORE YOU BEGIN

* **Carefully study the assembly drawings to the contents in this plastic kit.**

- * Each plastic part is identified by a number.
- * For better paint and decal adhesion, wash the plastic parts in a mild detergent solution. Rinse and let air dry.
- * Check the fit of each piece before cementing in place.
- * Use only cement for polystyrene plastic.
- * Scrape plating and paint from areas to be cemented.
- * Allow paint to dry thoroughly before handling parts.
- * Any unused parts may be discarded.

⚠ AVERTISSEMENT : LIRE CECI AVANT DE COMMENCER

* **Étudiez attentivement les dessins d'assemblage jusqu'au contenu de ce kit en plastique.**

- * Chaque pièce en plastique est identifiée par un numéro.
- * Pour une meilleure adhérence de la peinture et des décalcomanies, lavez les pièces en plastique dans une solution de détergent doux. Rincez et laissez sécher à l'air.
- * Vérifiez l'ajustement de chaque pièce avant de cimenter en place.
- * Utilisez seulement du ciment pour plastique polystyrène.
- * Raclez le placage et la peinture des zones à cimenter.
- * Laissez bien sécher la peinture avant de manipuler les pièces.
- * Toute pièce inutilisée peut être jetée.

⚠ ADVERTENCIA: LEER ESTO ANTES DE COMENZAR

* **Estudie cuidadosamente los dibujos de ensamblaje a los contenidos de este kit de plástico.**

- * Cada pieza de plástico se identifica con un número.
- * Para conseguir una mejor adhesión de las calcomanías, lavar las piezas de plástico con una solución de detergente suave. Enjuagar y dejar secar al aire.
- * Comprobar el ajuste de cada pieza antes de fijar en su sitio con cemento.
- * Usar sólo cemento para plástico de poliestireno.
- * Rasca el cromado y la pintura de las áreas que se vayan a pegar.
- * Dejar que la pintura se seque completamente antes de manipular las piezas.
- * Las piezas que no se utilicen pueden desecharse.

DECAL APPLICATION INSTRUCTIONS

1. Cut desired decal from sheet.
2. Dip decal in water for a few seconds.
3. Place wet decal on paper towel.
4. Wait until decal is movable on paper backing.
5. Place decal in position on model, face up and slide backing away.
6. Press out air bubbles with a soft damp cloth.
7. Milkyness that may appear is for better decal adhesion and will dry clear. Wipe away any excess adhesive.
8. Do not touch decal until fully dry.
9. Allow the decals 48 hours to dry before applying clear coat.
10. Decals are compatible with setting solutions or solvents.

INSTRUCTIONS D'APPLICATION DES DÉCALCOMANIES

1. Coupez la décalcomanie souhaitée sur la feuille.
2. Trempez la décalcomanie dans l'eau quelques secondes.
3. Placez la décalcomanie mouillée sur un essuie-tout.
4. Attendez que la décalcomanie puisse bouger sur son support papier.
5. Placez la décalcomanie en position sur la maquette, la face vers le haut et enlevez le support papier en le glissant.
6. Expulsez les bulles d'air en pressant avec un chiffon humide doux.
7. Le voile laiteux qui peut apparaître permet la meilleure adhérence des décalcomanies et disparaît une fois sec. Essuyez l'excédent de colle.
8. Ne touchez pas à la décalcomanie tant qu'elle n'est pas entièrement sèche.
9. Laissez sécher les décalcomanies pendant 48 heures avant d'appliquer la couche transparente.
10. Les décalcomanies sont compatibles avec les accélérateurs de prise et les solvants.

INSTRUCCIONES DE APLICACIÓN DE LAS CALCOMANÍAS

1. Cortar la calcomanía deseada de la hoja.
2. Sumergir la calcomanía en agua por unos segundos.
3. Poner la calcomanía en una toalla de papel.
4. Esperar hasta que la calcomanía se mueva sobre el respaldo de papel.
5. Colocar la calcomanía en su sitio sobre la maqueta, bocarriba, y deslizar el respaldo para quitarlo.
6. Presionar con un paño suave humedecido para eliminar las burbujas de aire.
7. El aspecto lechoso que podría ocurrir mejora la adhesión y desaparecerá al secarse. Limpiar el exceso de adhesivo.
8. No tocar la calcomanía hasta que se haya secado completamente.
9. Esperar 48 horas para permitir que las calcomanías se sequen antes de aplicar el barnizado.
10. Las calcomanías son compatibles con las soluciones endurecedoras y los solventes.

CUSTOMER SERVICE

If you have questions or problems visit our website revell.com or write to us at:

**Revell GmbH, Consumer Service,
Henschelstr. 20-30, 32257 Bünde, Germany**

Be sure to include this plan number (15872-0389), part number, description and your return address and phone number.

SERVICE CLIENTÈLE

En cas de questions ou problèmes, consultez notre site [Web revell.com](http://Web.revell.com) ou écrivez-nous à :

**Revell GmbH, Consumer Service,
Henschelstr. 20-30, 32257 Bünde, Germany**

Veillez à inclure ce numéro de plan (15872-0389), le numéro de pièce, la description de la pièce, votre adresse de retour et votre numéro de téléphone.

ATENCIÓN AL CLIENTE

Si tiene alguna pregunta o problema, visite nuestro sitio web, revell.com, o escribanos a:

**Revell GmbH, Consumer Service,
Henschelstr. 20-30, 32257 Bünde, Germany**

Asegúrese de incluir el número de plan (15872-0389), número de pieza, descripción, y su dirección postal y número de teléfono.



Glue
Coller
Pegamento



Don't glue
Ne pas coller
No pegamento



Paint
Peindre
Pintar



Number of working steps.
Nombre d'étapes de travail.
Número de pasos de trabajo.



Sequence of assembly.
Ordre d'assemblage.
Secuencia de montaje.



Optional
Facultatif
Opcional



Allow the parts to dry.
Laisser sécher les pièces.
Dejar secar las piezas.



Remove
Détacher
Eliminar



Detach with knife.
Détacher au couteau.
Separar con cuchillo.



Illustration of assembled parts.
Figure représentant les pièces assemblées.
Figura de las piezas montadas.



Attach with adhesive tape.
Fixer à l'aide de ruban adhésif.
Fijar con cinta adhesiva.



Repeat same procedure on opposite side.
Opérer de la même façon sur l'autre face.
Repetir el mismo procedimiento en el lado contrario.



Clear parts
Pièces transparentes
Piezas transparentes



Read the assembly instructions carefully.
Lisez attentivement les instructions de montage.
Lea cuidadosamente las instrucciones de montaje.



Soak and apply decals.
Mouiller et appliquer les décalcomanies.
Mojar y aplicar calcomanías.



Recommended for affixing the decals.
Recommandé pour l'application des décalcomanies.
Recomendado para fijar bien las calcomanías.





Recommended to fix clear parts.
Recommandé pour fixer les pièces transparentes.
Recomendado para fijar las piezas transparentes.

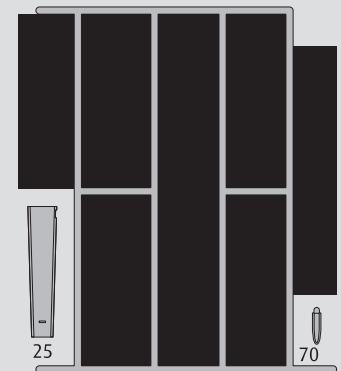
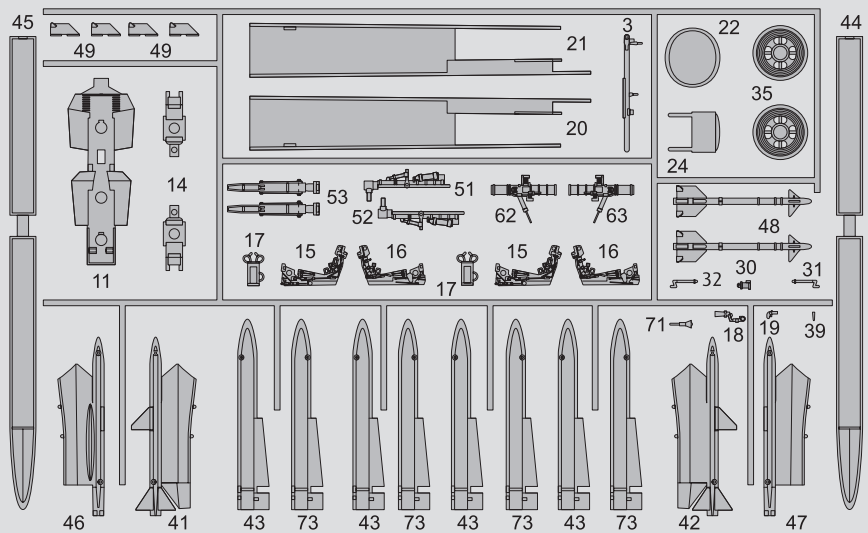
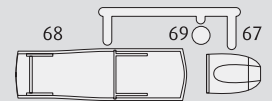
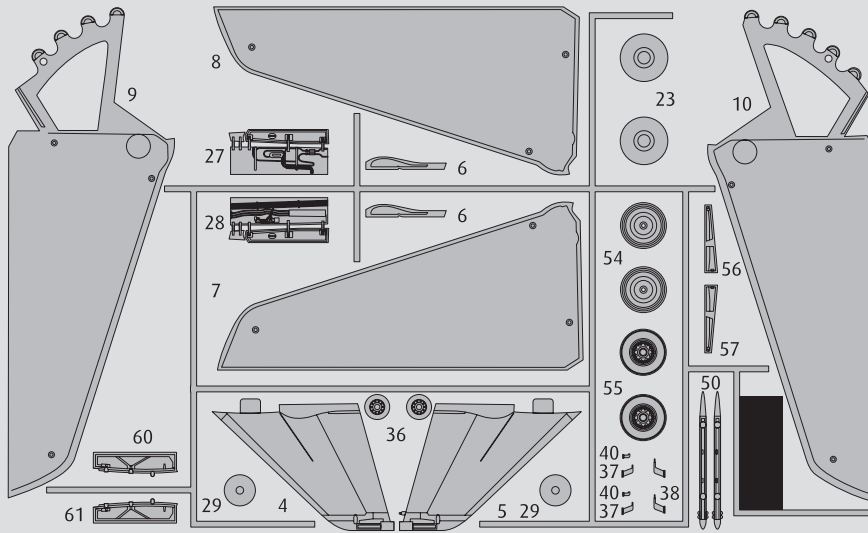
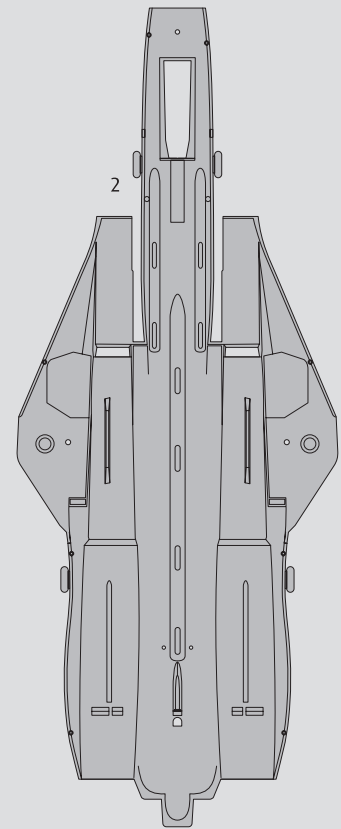
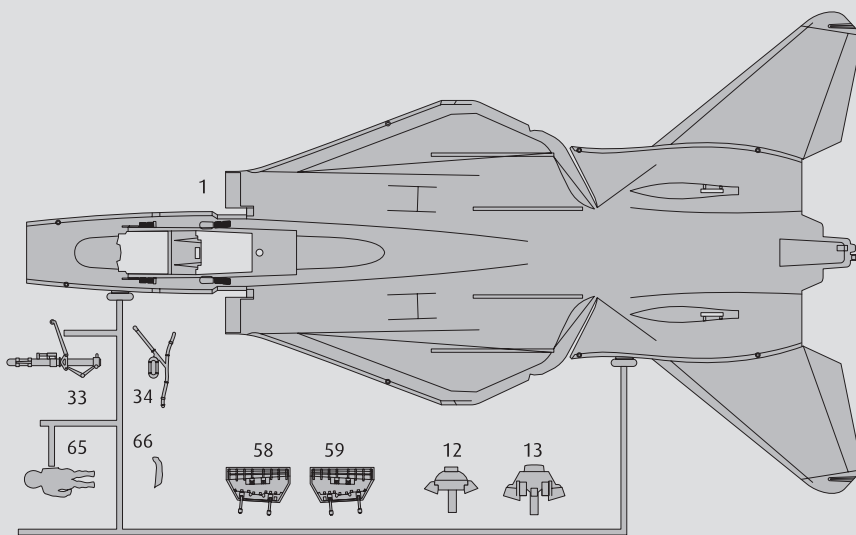

Not included
Non fourni
No incluido

| REVELL | PAINT GUIDE | GUIDE DE PEINTURE | GUÍA DE PINTURA |
|---------------------------------|---------------------------|-------------------------------|--------------------------------|
| A 302 | Flat Black | Noir mat | Negro mate |
| B 310 | Semi Gloss Dark Yellow | Jaune foncé semi brillant | Amarillo semi oscuro brillante |
| C 371 | Semi Gloss Light Gray | Gris clair semi-brillant | Semi Brillante Gris Claro |
| D 301 | Semi Gloss White | Blanc semi brillant | Blanc semi brillante |
| E 86 | Flat Khaki Brown | Brun kaki plat | Marrón caqui plano |
| F 09 | Flat Anthracite | Anthracite plat | Antracita Plana |
| G 91 + 83 (90%) (10%) | Iron Metallic / Flat Rust | Fer métallisé / Rouille plate | Hierro metálico / Óxido plano |
| H 90 | Silver Metallic | Argent métallisé | Plata metalizado |
| I 330 | Semi Gloss Red | Rouge semi brillant | Rojo semibrillante |
| J 364 | Semi Gloss Green | Vert semi brillant | Verde semi brillante |
| K 91 | Iron Metallic | Fer métallisé | Hierro metálico |
| L 75 | Flat Stone Grey | Gris pierre plate | Flat Stone Grey |
| M 45 | Flat Light Olive | Olive clair plat | Oliva plana clara |
| N 43 | Flat Medium Grey | Gris moyen plat | Gris medio plano |
| O 76 | Flat Light Grey | Gris clair plat | Gris claro plano |
| P 65 | Flat Bronze Green | Plat Bronze Vert | Verde bronce plano |
| Q 57 | Flat Grey | Gris Plat | Gris plano |



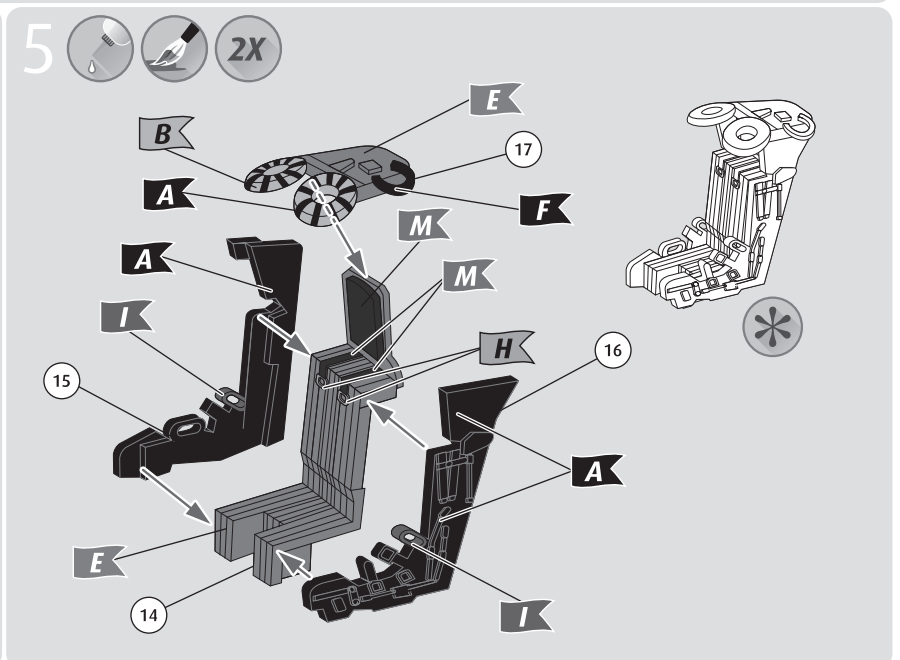
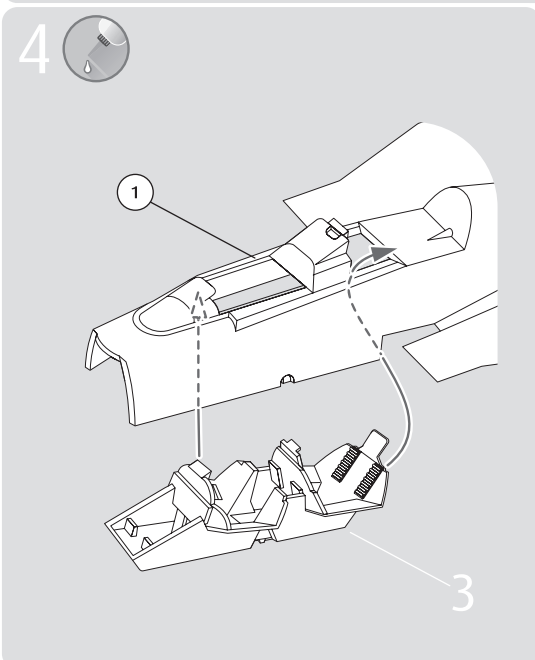
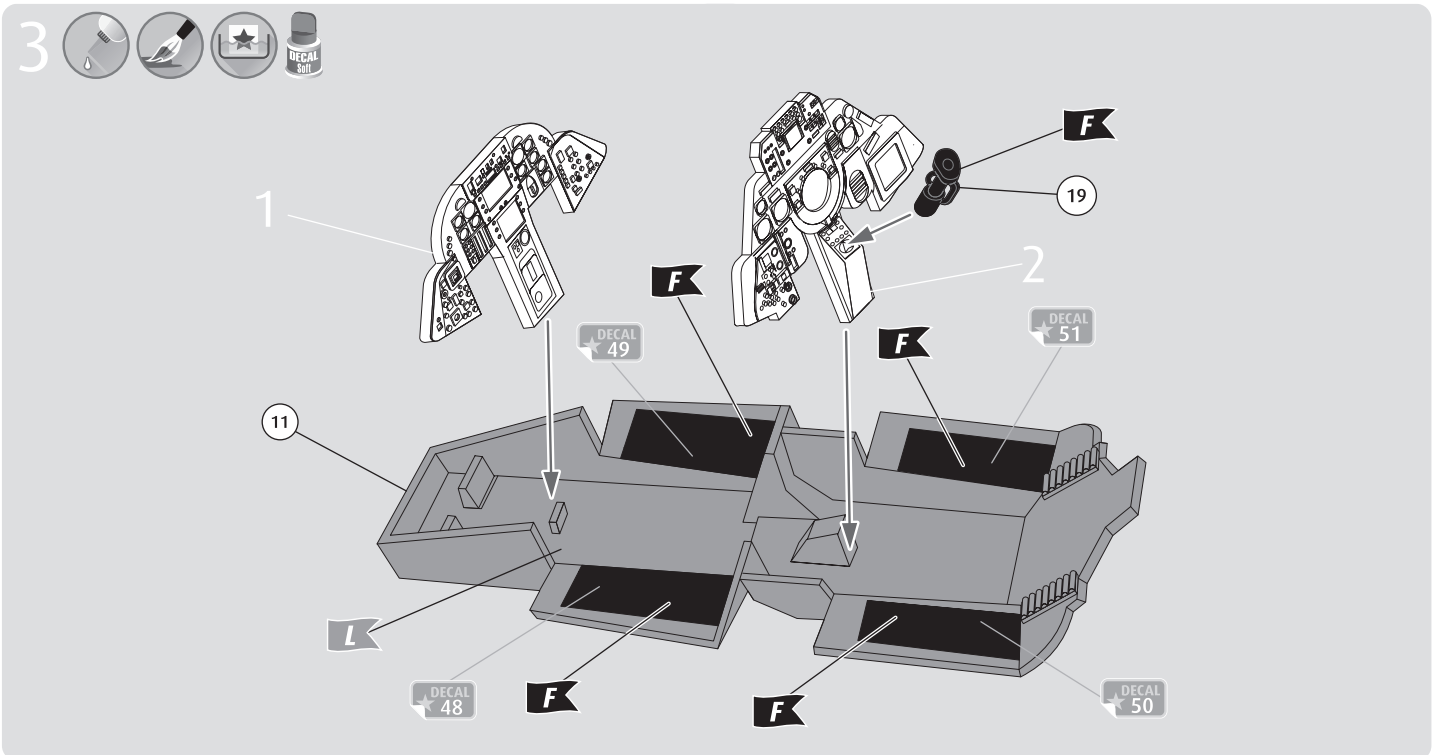
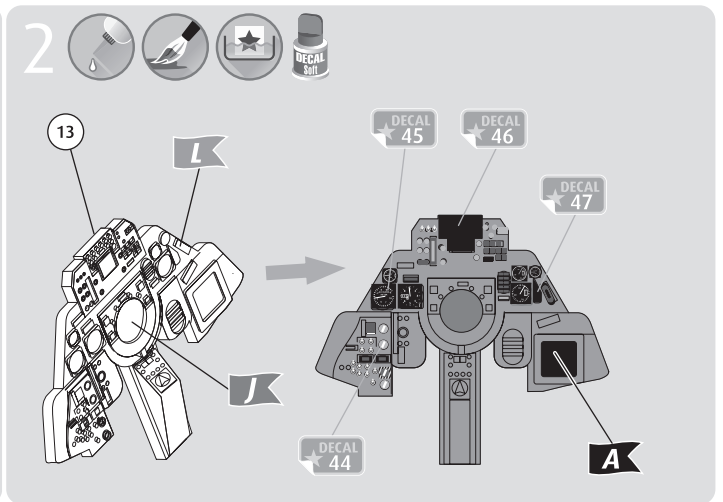
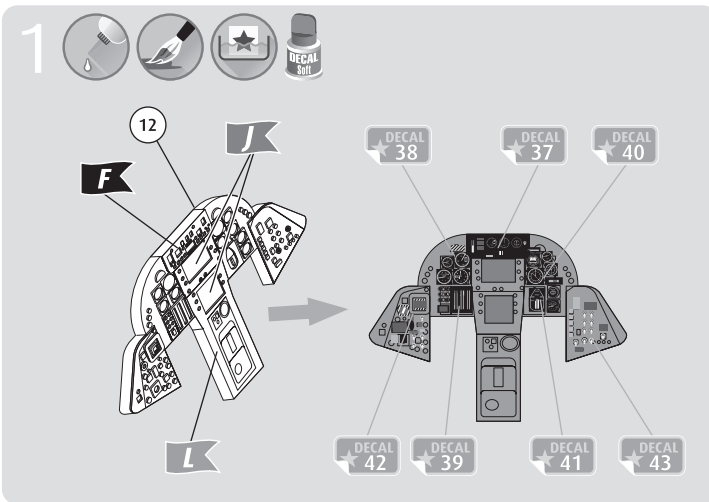

 Parts not used.
 Pièces non utilisées.
 Piezas no utilizadas.

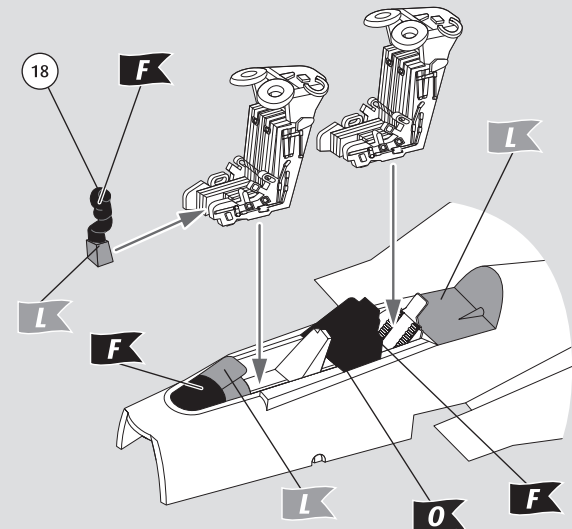

6

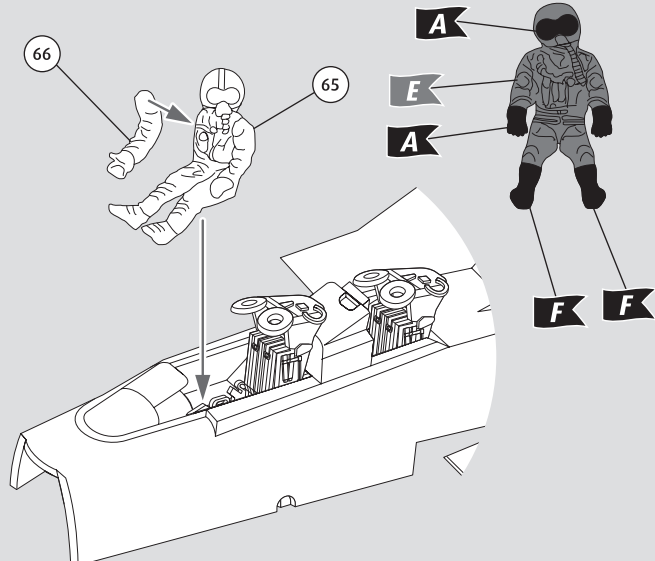

7



8

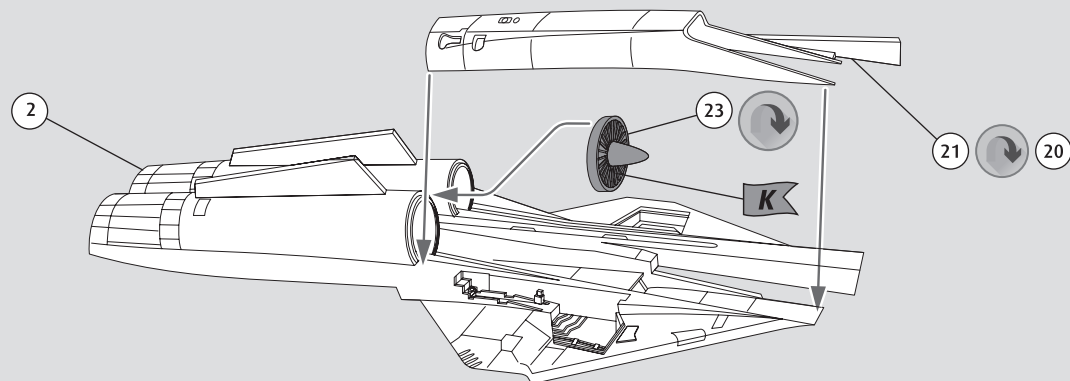

9

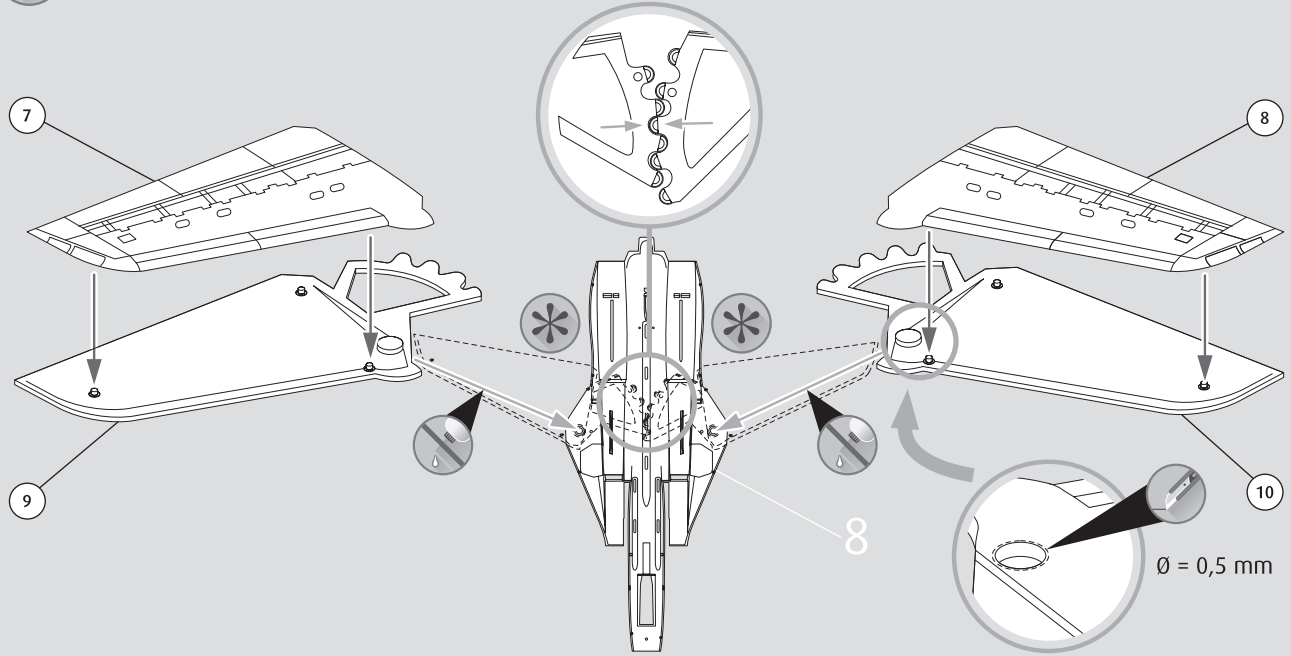

10

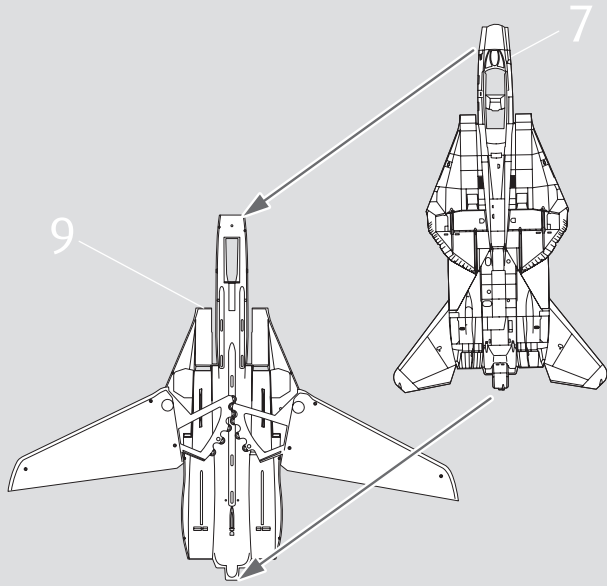

11

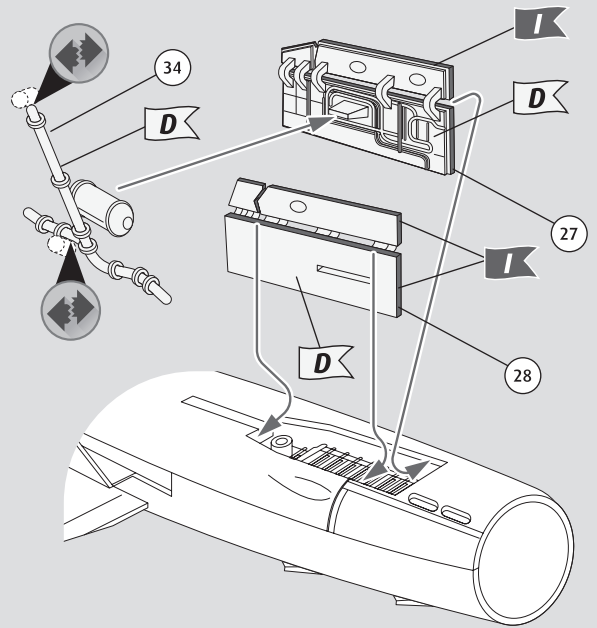

12

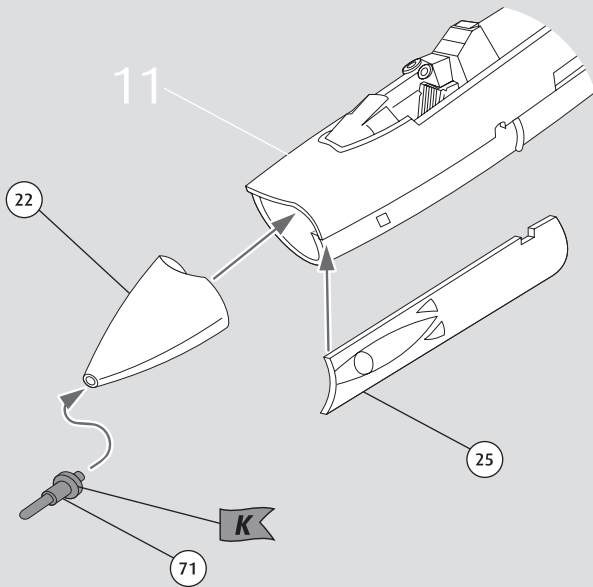

13

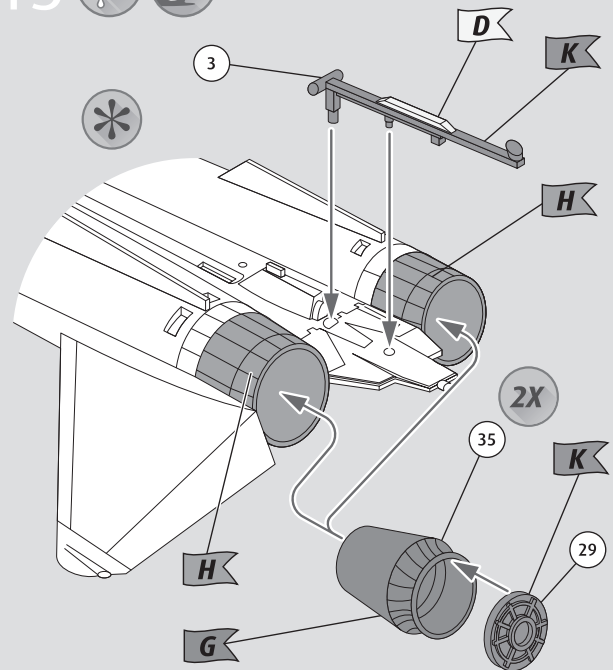

14

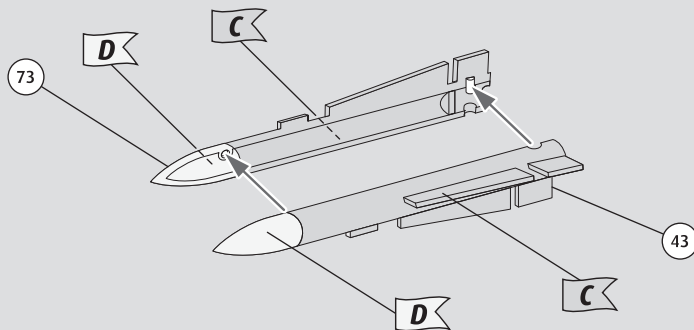

15

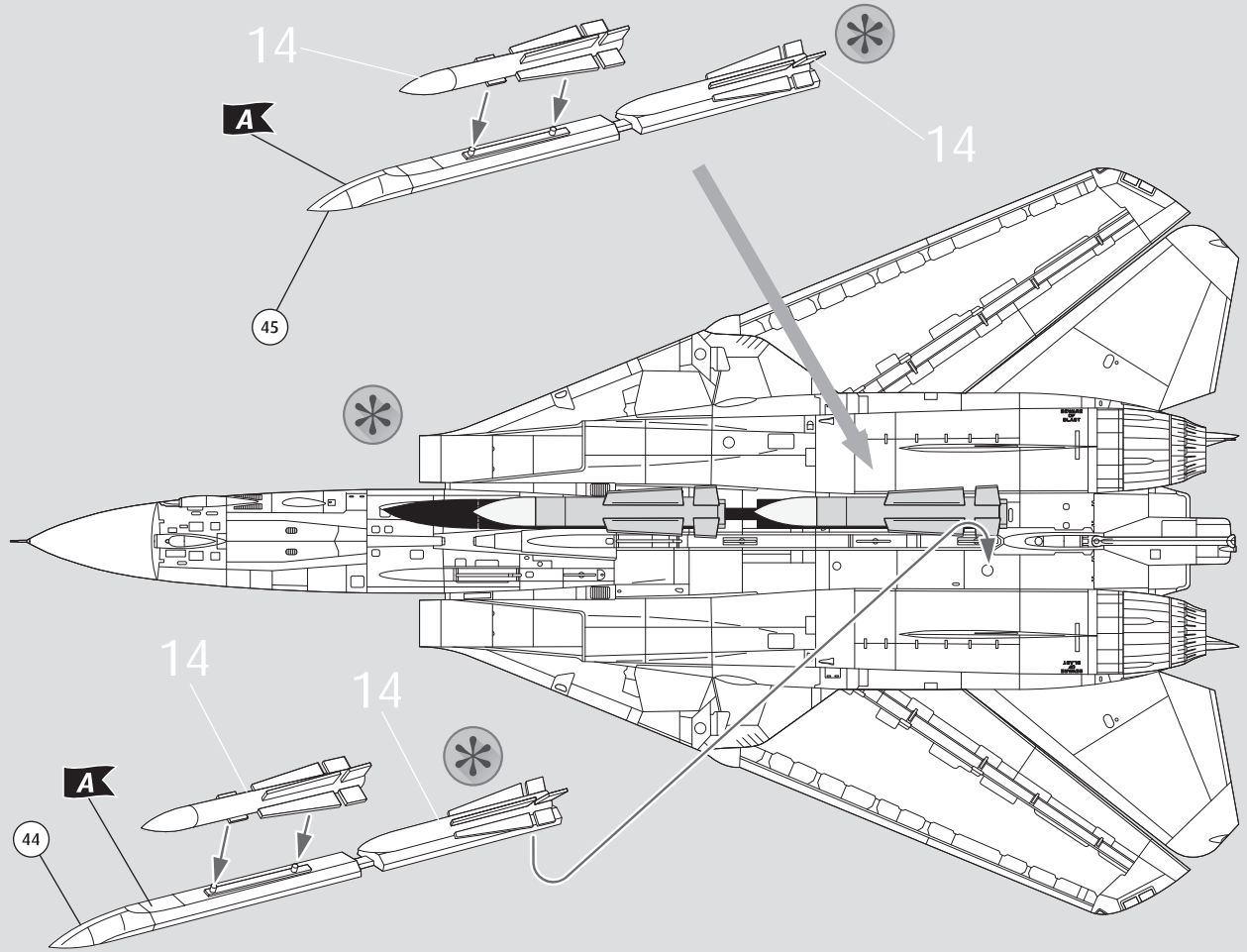

16

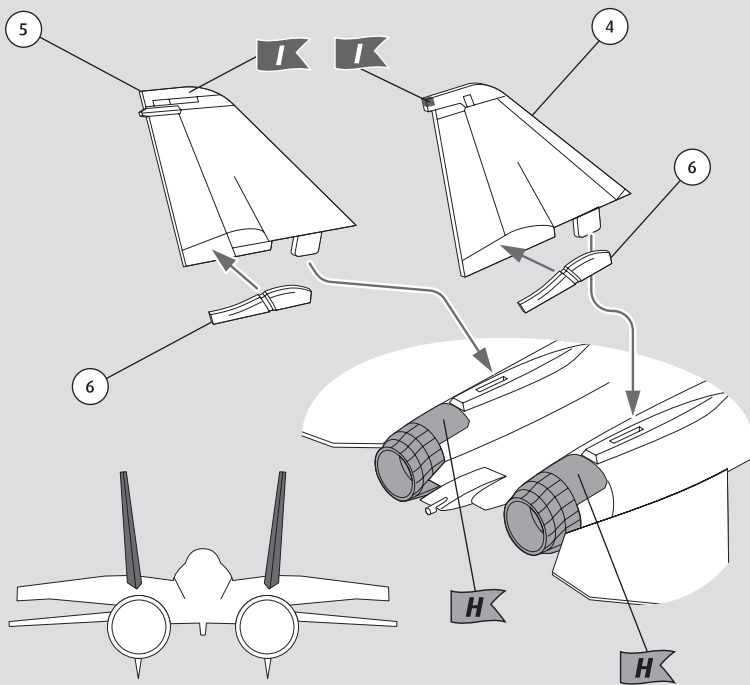

17

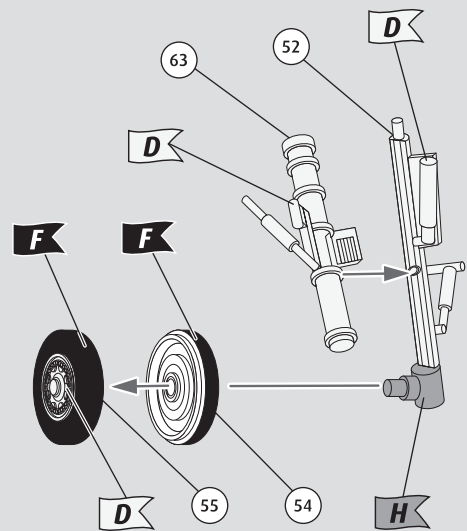

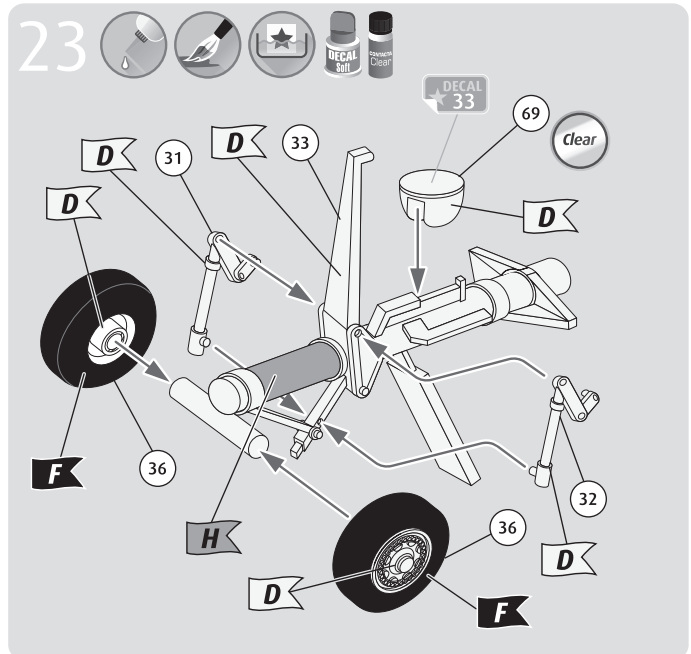
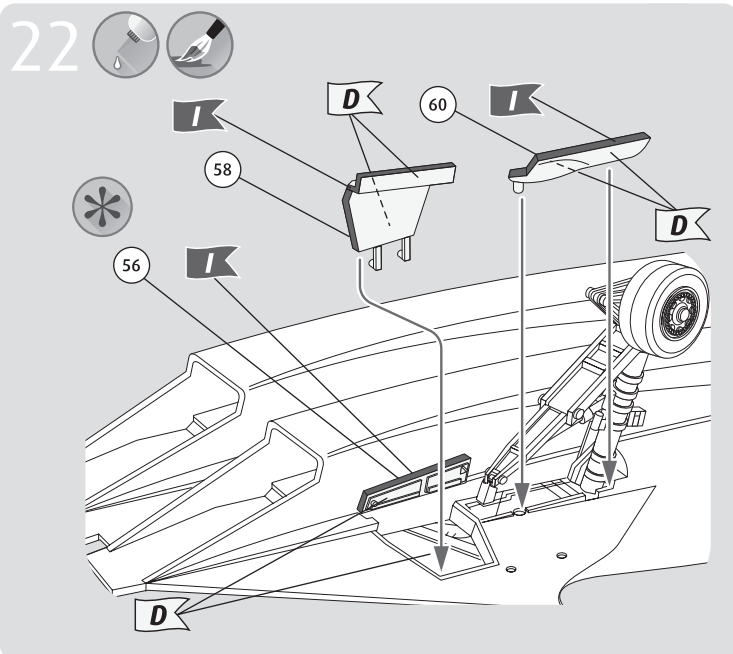
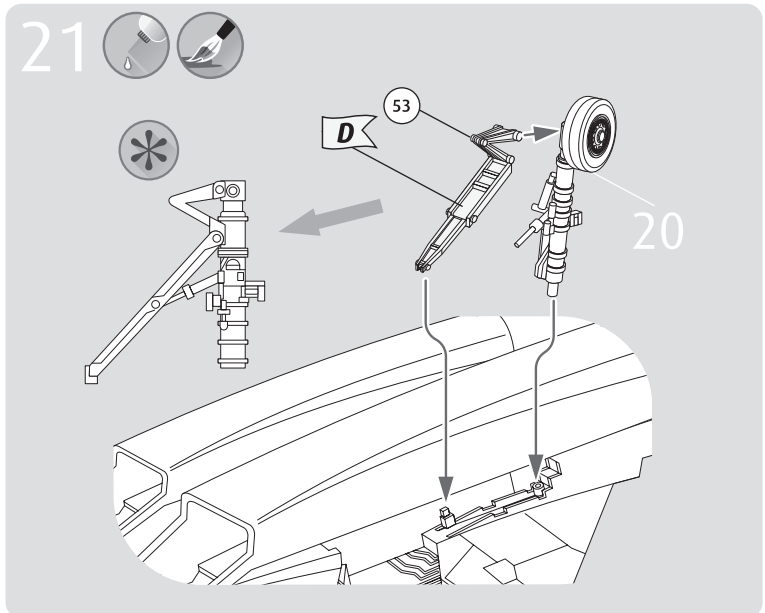
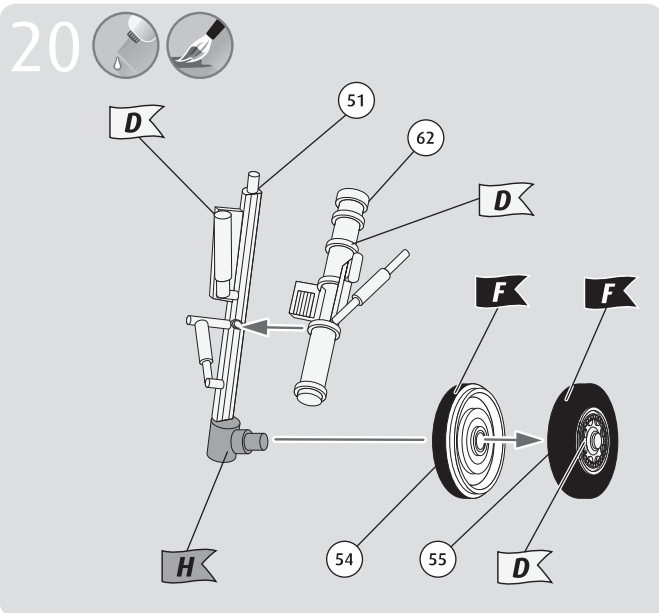
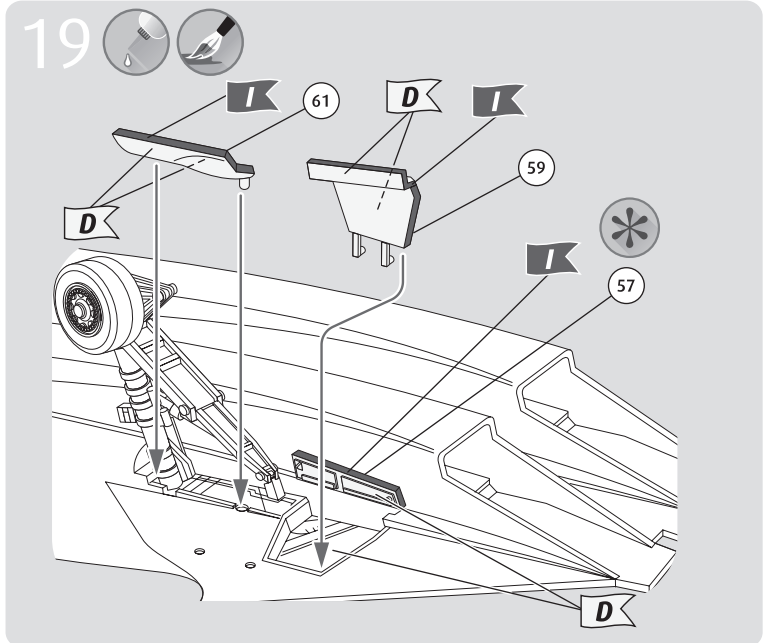
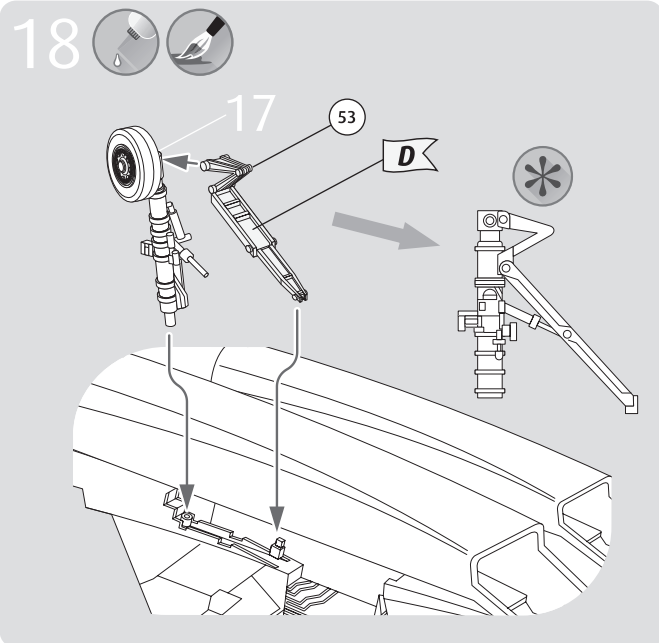

24

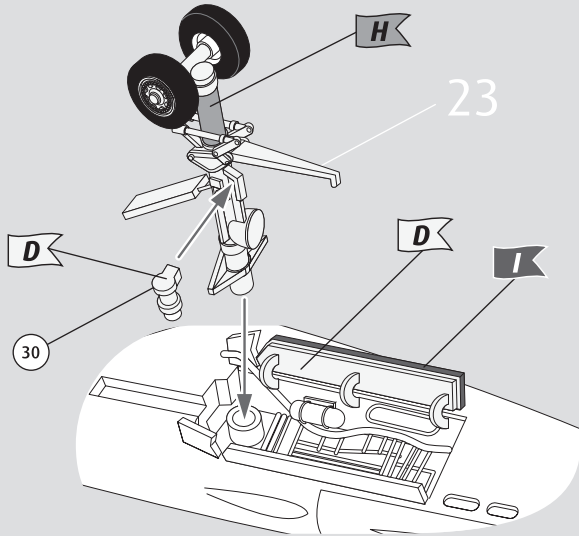

25

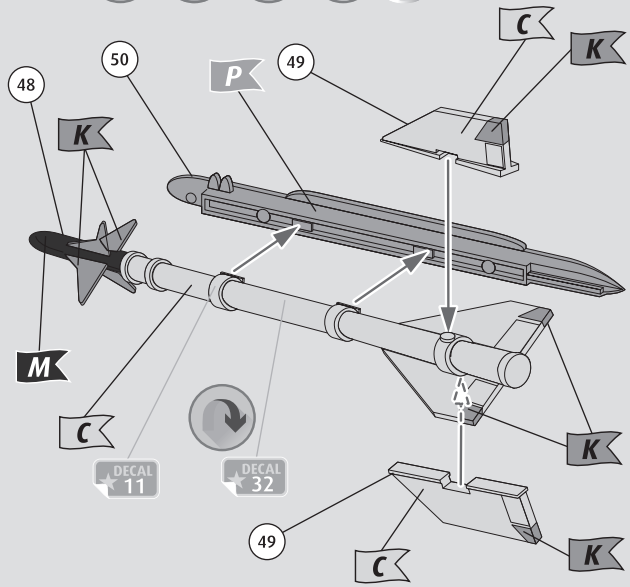

26

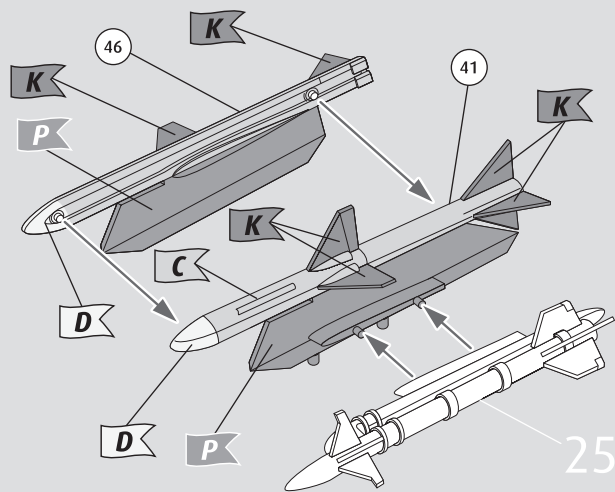

27

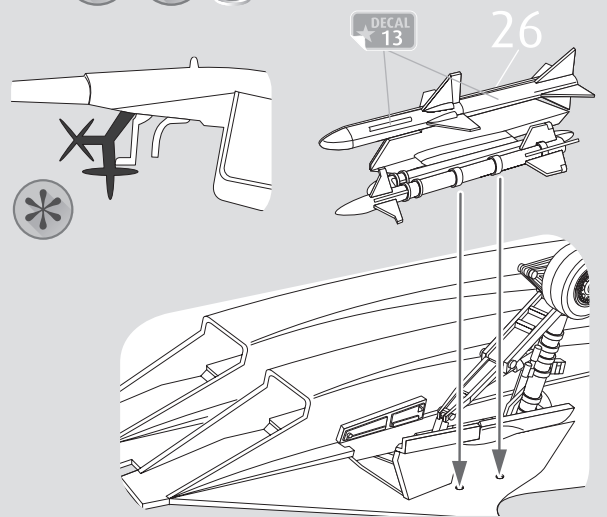

28

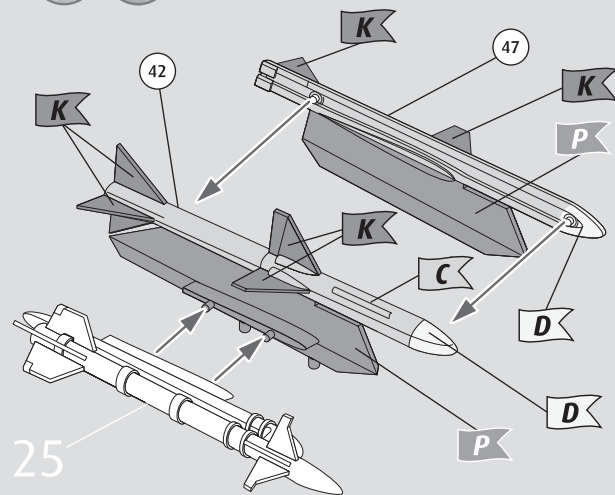

29

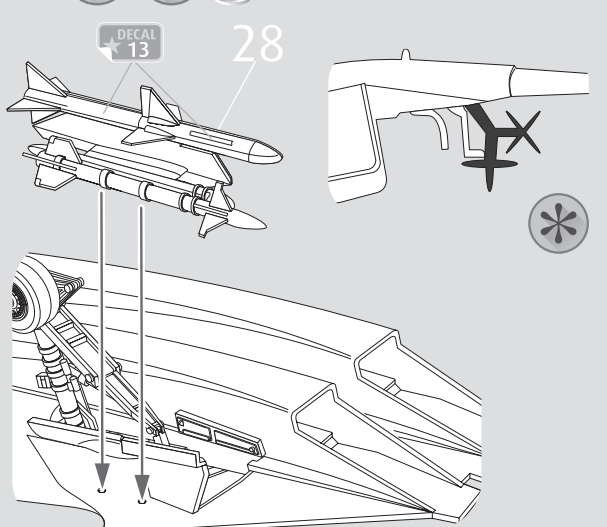

30

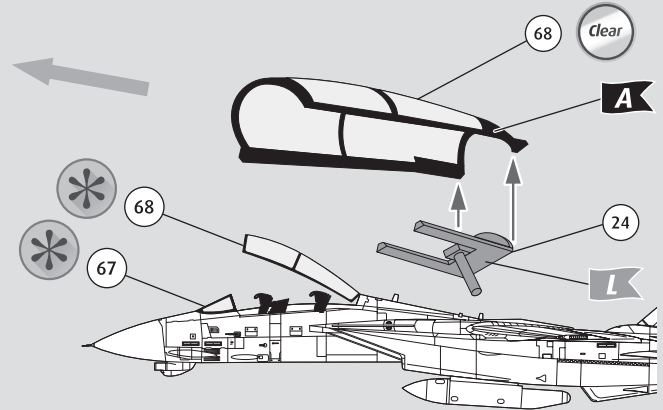
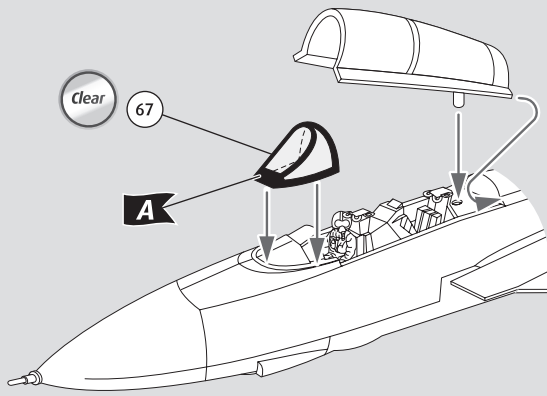

31

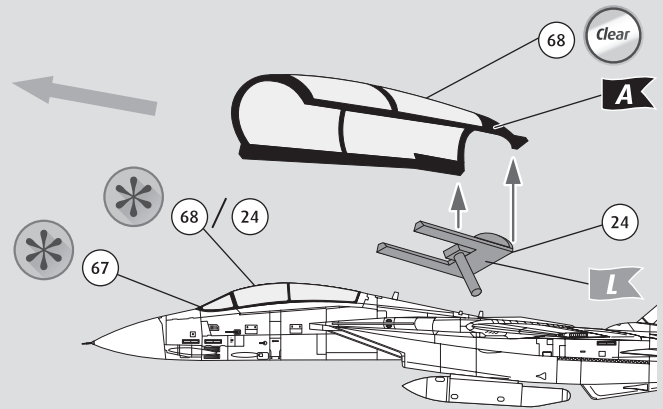
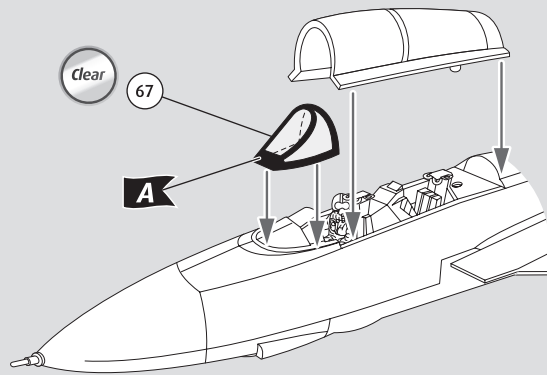

32

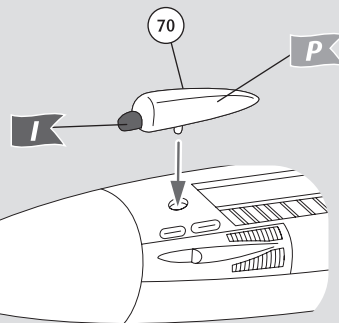

33

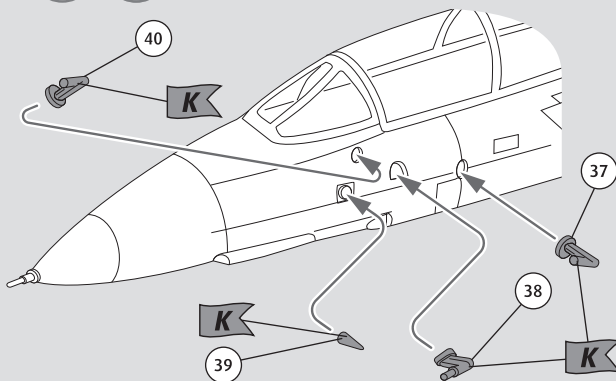

34

