

# M60A1 w/EXPLOSIVE REACTIVE ARMOR

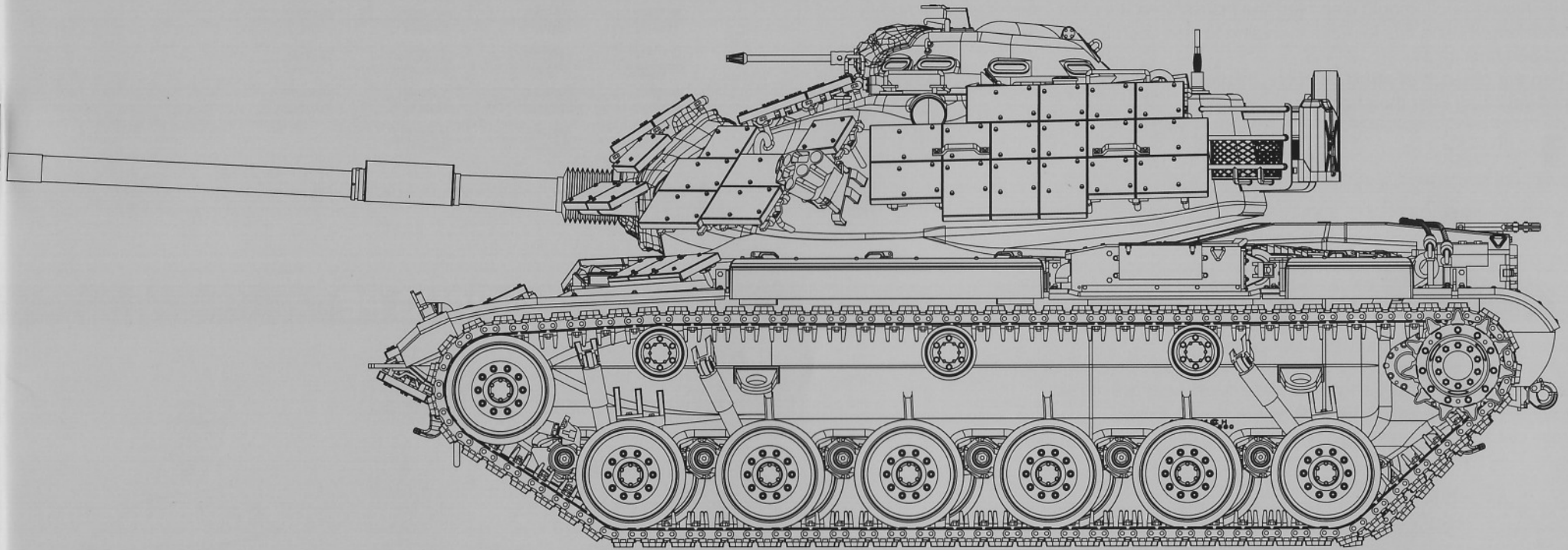

Evolving from the M48 through the M60, the M-60A1 Patton tank was produced from 1962 through 1980. This newer variant featured a redesigned wedge-shaped turret with improved ballistic protection and a new mounting for the 105mm M68 main gun (modified from the excellent British L7 with a vertical sliding breech block), which could fire HE, Frag, AP, and HEAT rounds. Additional armament consisted of a coaxially mounted 7.62 mm M73 machine gun and a 12.7 mm M85 machine gun mounted in the commander's cupola. Further improvements consisted of increased armor thickness on the glacis and hull sides, as well as the installation of shock absorbers at the first two and last roadwheel stations. Powered by the improved 643 hp Continental AVDS-1790-2A V-12 twin turbo diesel engine coupled to the Allison CD-850-6A powershift cross-drive transmission, the tank weighed 58 tons and was served by a crew of four -- commander, gunner, loader, and driver. This vehicle became the main battle tank fielded by the US Armed forces through the 1960's into the early 1970's.

The ultimate development of the M-60A1 was the M-60A1 RISE (RISE= Reliability Improvements for Selected Equipment). These were rebuilt M-60A1's, with added passive 'starlight' scopes for the driver, gunner and commander, eliminating the need for the bulky IR projector above the main gun. Other improvements included the Continental AVDS-1790-2C engine, which helped to boost engine power. A battery of smoke dischargers was also added to either side of the turret, like the set-up on the Chieftain tank. These vehicles were quickly supplied to frontline units overseas, such as in Germany, by early 1979.

Deployed to Operation Desert Shield in 1990, the United States Marines Corps' main battle tank was retrofitted with explosive reactive armor (ERA) tiles to further increase crew protection. During Operation Desert Storm, the 1st Marine Expeditionary Force fielded 210 M60A1's to support the liberation of Kuwait, destroying over 100 Iraqi T-55/62/72 & Type 69-II tanks (and losing only one to anti-tank mines).

03.02.2113

# READ BEFORE ASSEMBLY

## CAUTION

- Read carefully and fully understand the instructions before commencing assembly. A supervising adult should also read the instructions if a child assembles the model.
- When assembling this kit, tools including knives used. Extra care should be taken to avoid personal injury.
- Keep out of reach of small children. Children must not be allowed to suck any part, or pull vinyl bag over their heads.



Optional



Do Not Cement



Instant Glue for Metal



Drill



Remove



Fill Holes

## PAINTS REQUIRED

Color info and profiles by Mig Jimenez

A.MIG 033 Rubber & Tires	A.MIG 035 Dark Tracks	A.MIG 045 Gun Metal	A.MIG 071 Khaki
A.MIG 094 Crystal Glass	A.MIG 095 Crystal Smoke	A.MIG 099 Crystal Black Blue	A.MIG 195 Silver
A.MIG 025 U.S Modern Vehicles	A.MIG 046 Matt Black	A.MIG 016 Gelbraun	A.MIG 073 Earth
A.MIG 085 Oil Ochre	A.MIG 081 US Olive Drab	A.MIG 072 Dust	

## APPLYING DECALS

1. Clean the model surface with a wet cloth.
2. Cut out each decal design from sheet, and dip it in tepid water for 15~20 sec.
3. Hold the backing sheet edge and slide decal onto the model.
4. Move decal into position by wetting decal with finger.
5. Press decal gently down with a soft cloth until excess water and air bubbles are gone.

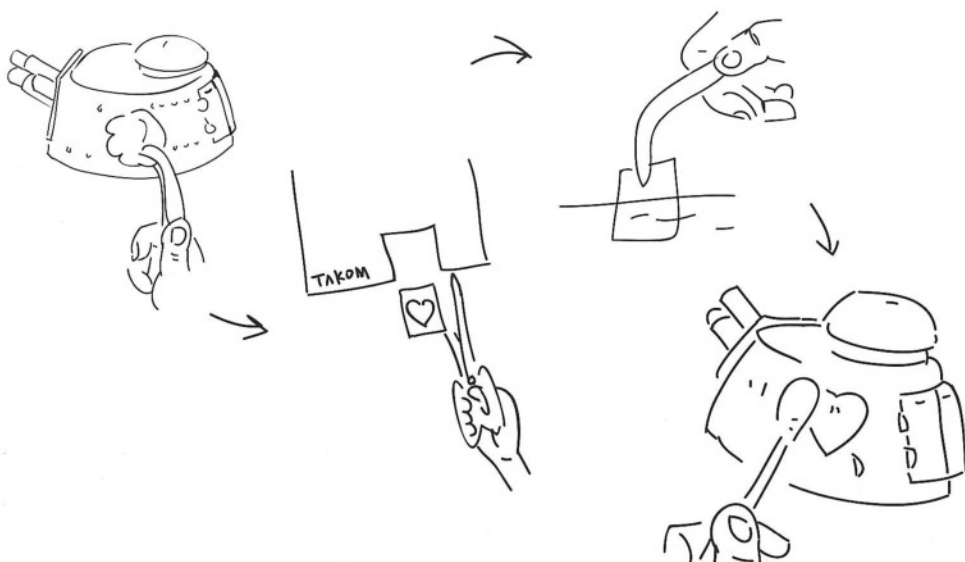

## REMOVING PE

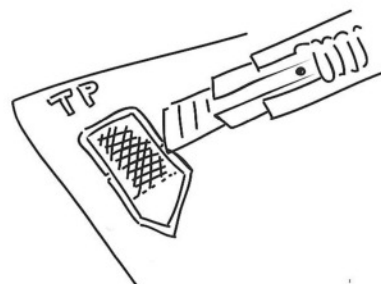

Be careful not to hurt when removing PE parts.

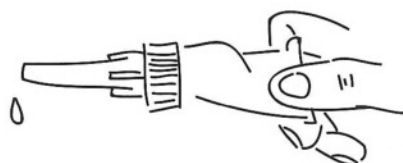

Secure using instant glue (not included).

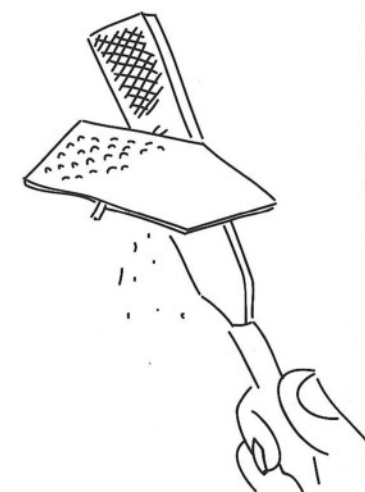

Finish using file.

# PARTS

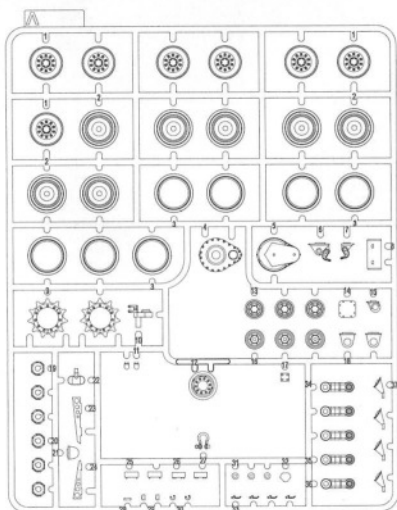

X2

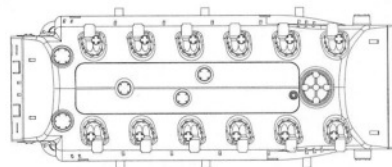
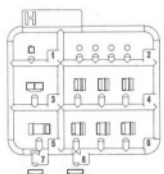

Lower Hull



X2

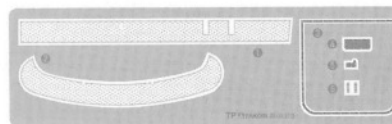
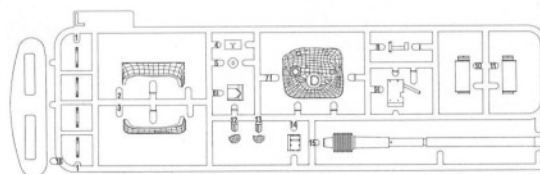
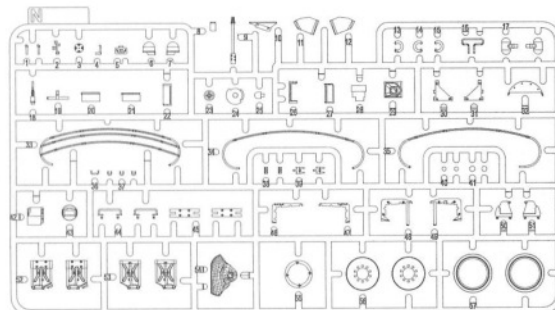
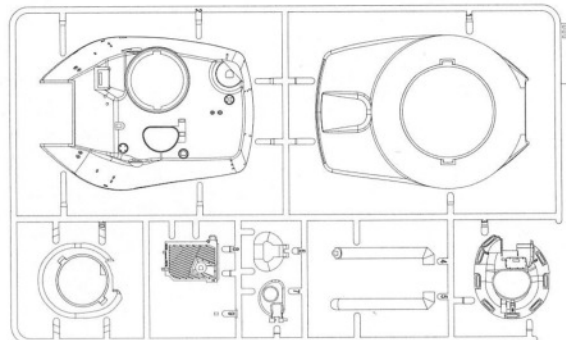
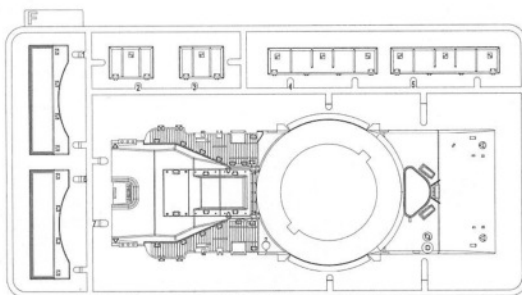
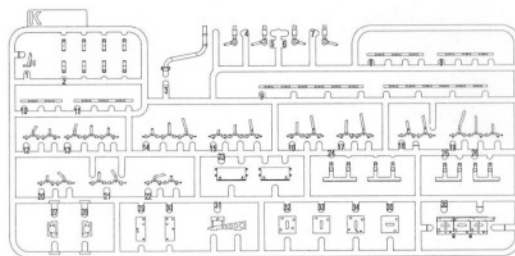
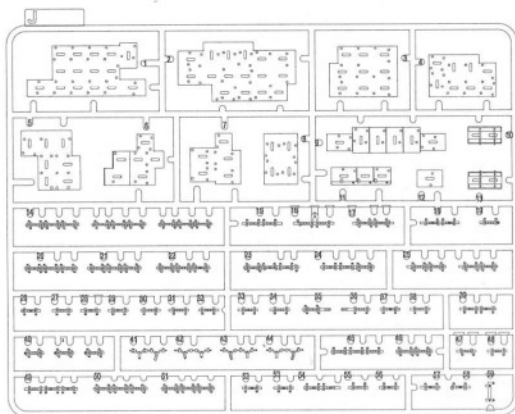

TP

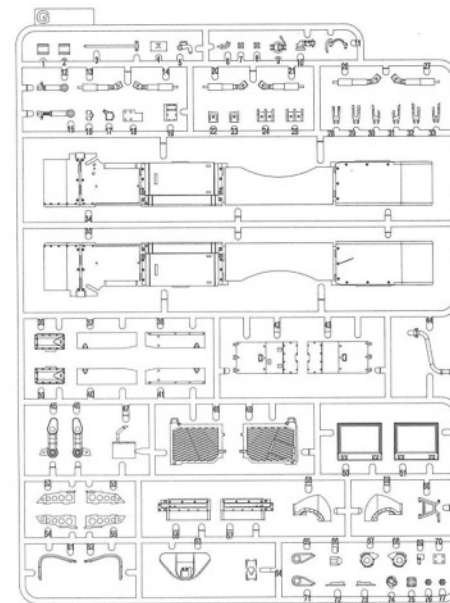

Cable

X2

Steel Pins

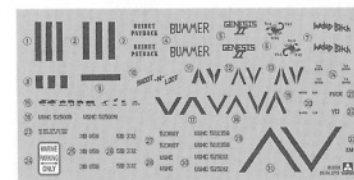

Decal

1

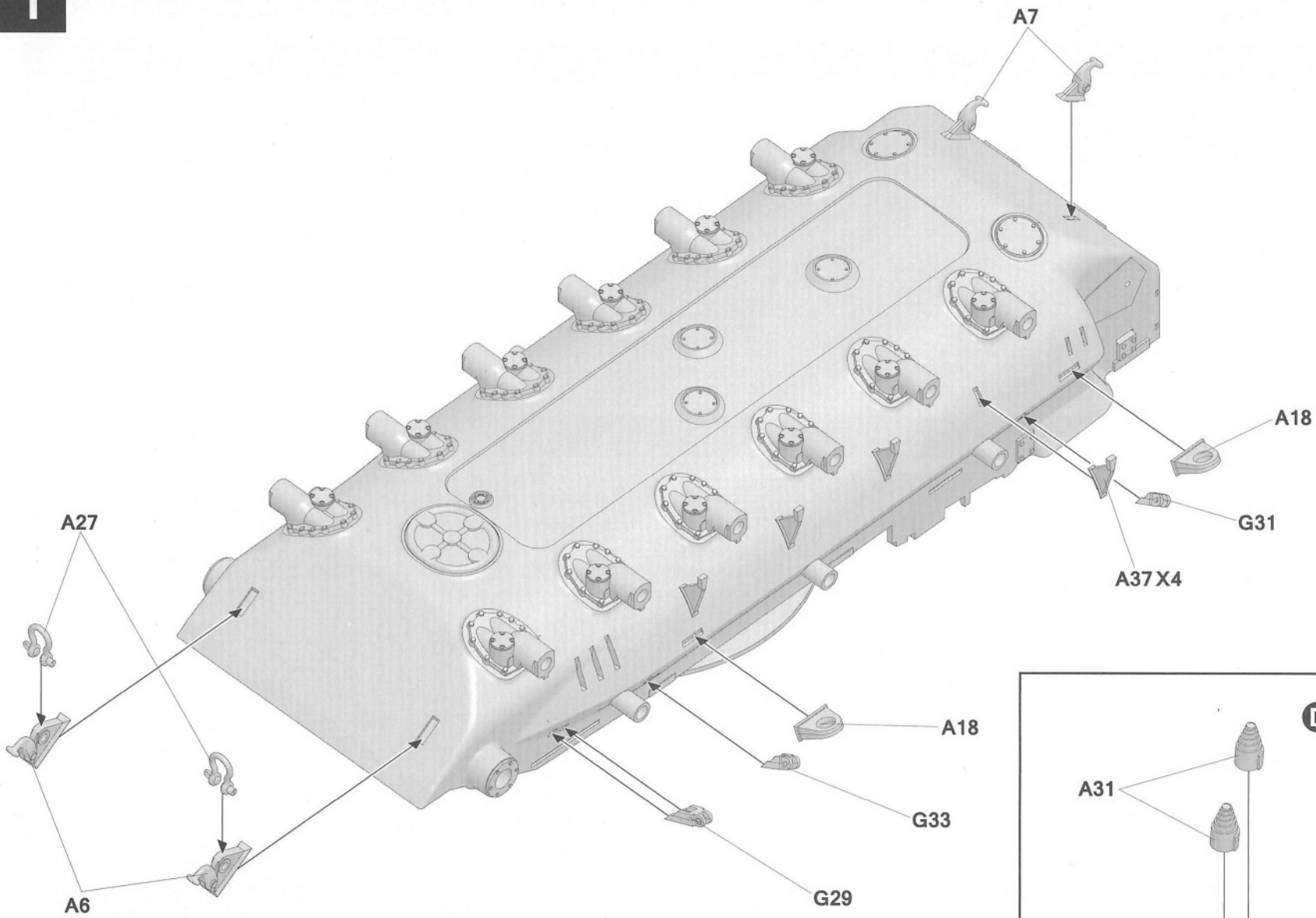

2

A

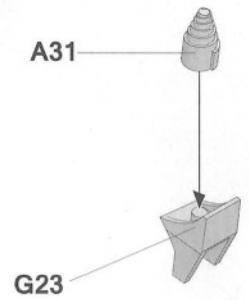

B

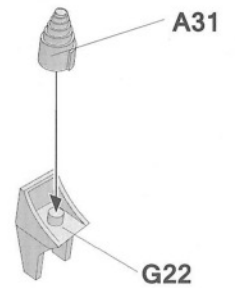

C

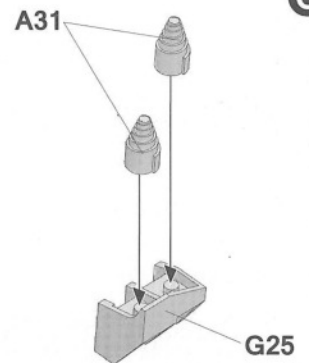

D

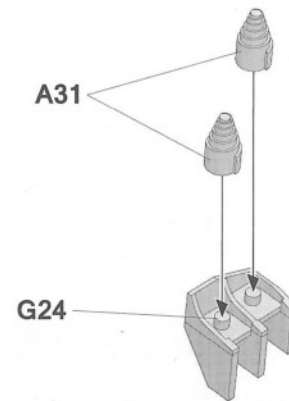

3

3

E

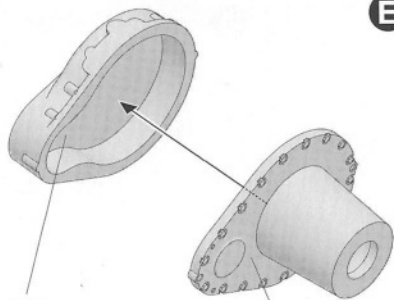

A5

A4

Make 2

C

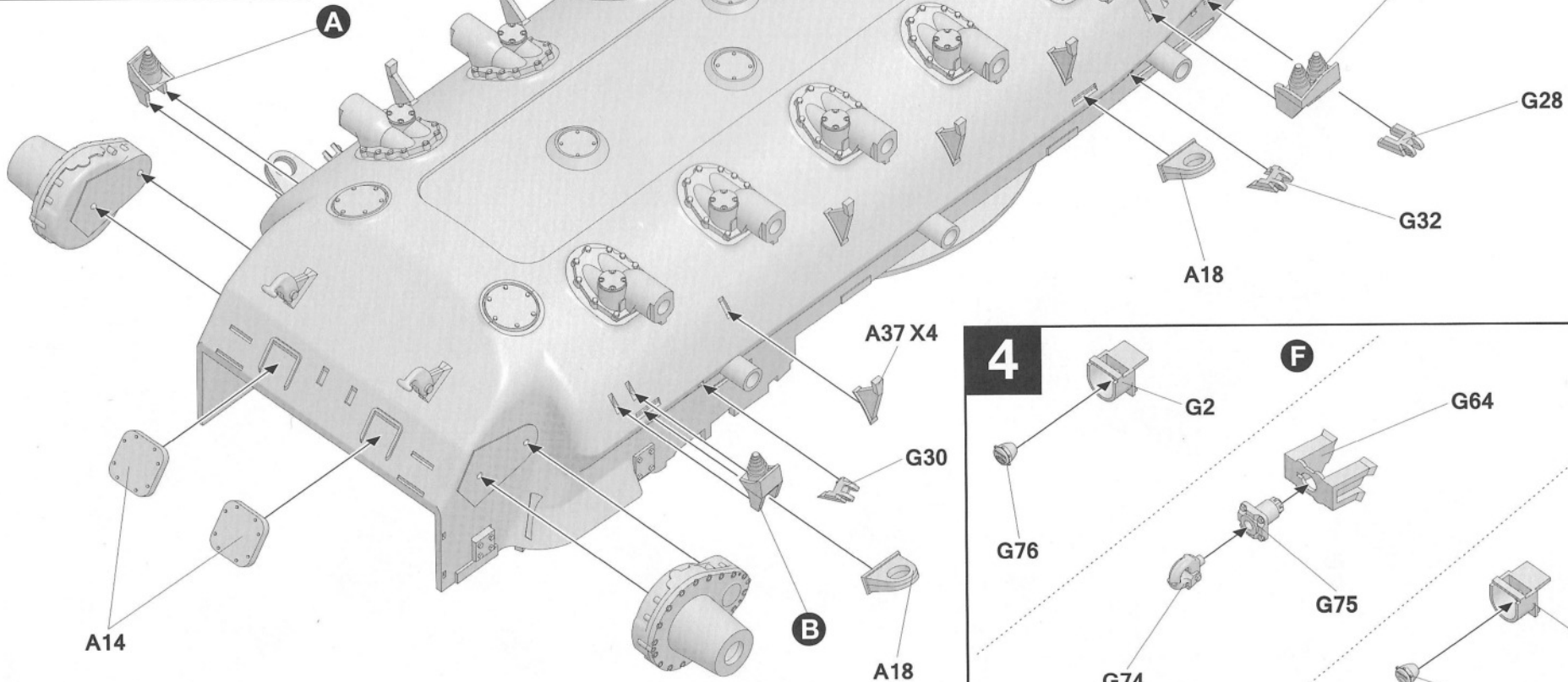

D

G28

G32

A18

A37 X4

G30

B

A18

A14

4

F

G

H

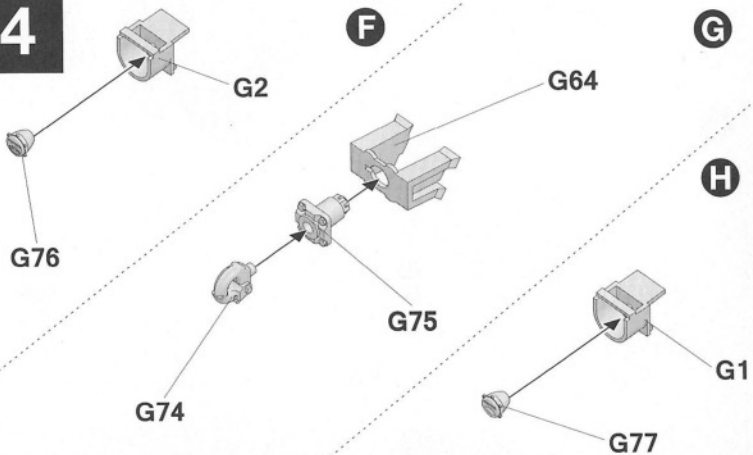

G2

G64

G76

G75

G74

G1

G77

4

5

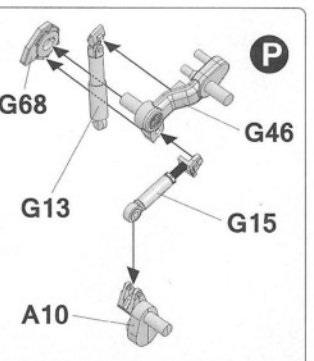
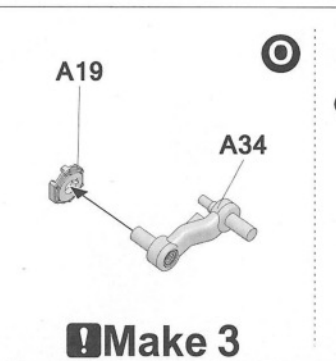
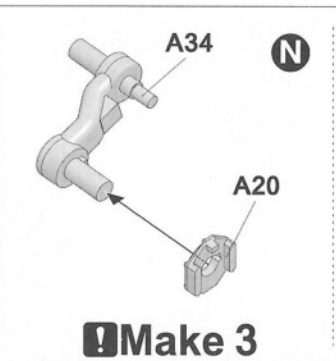
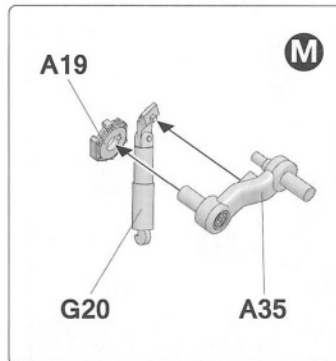
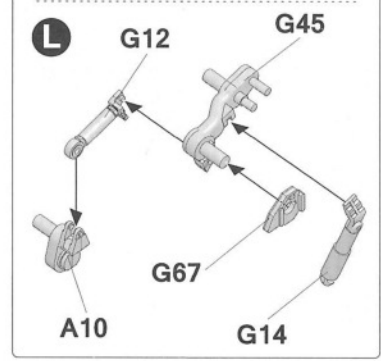
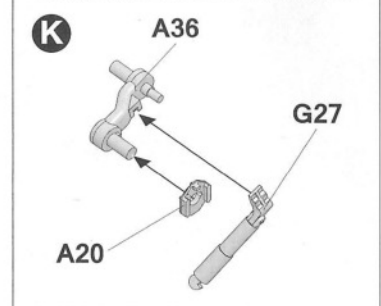
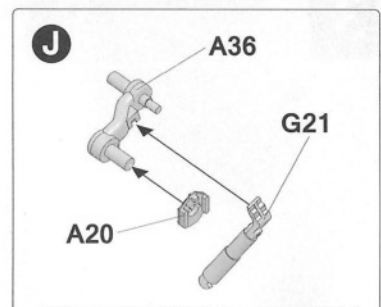
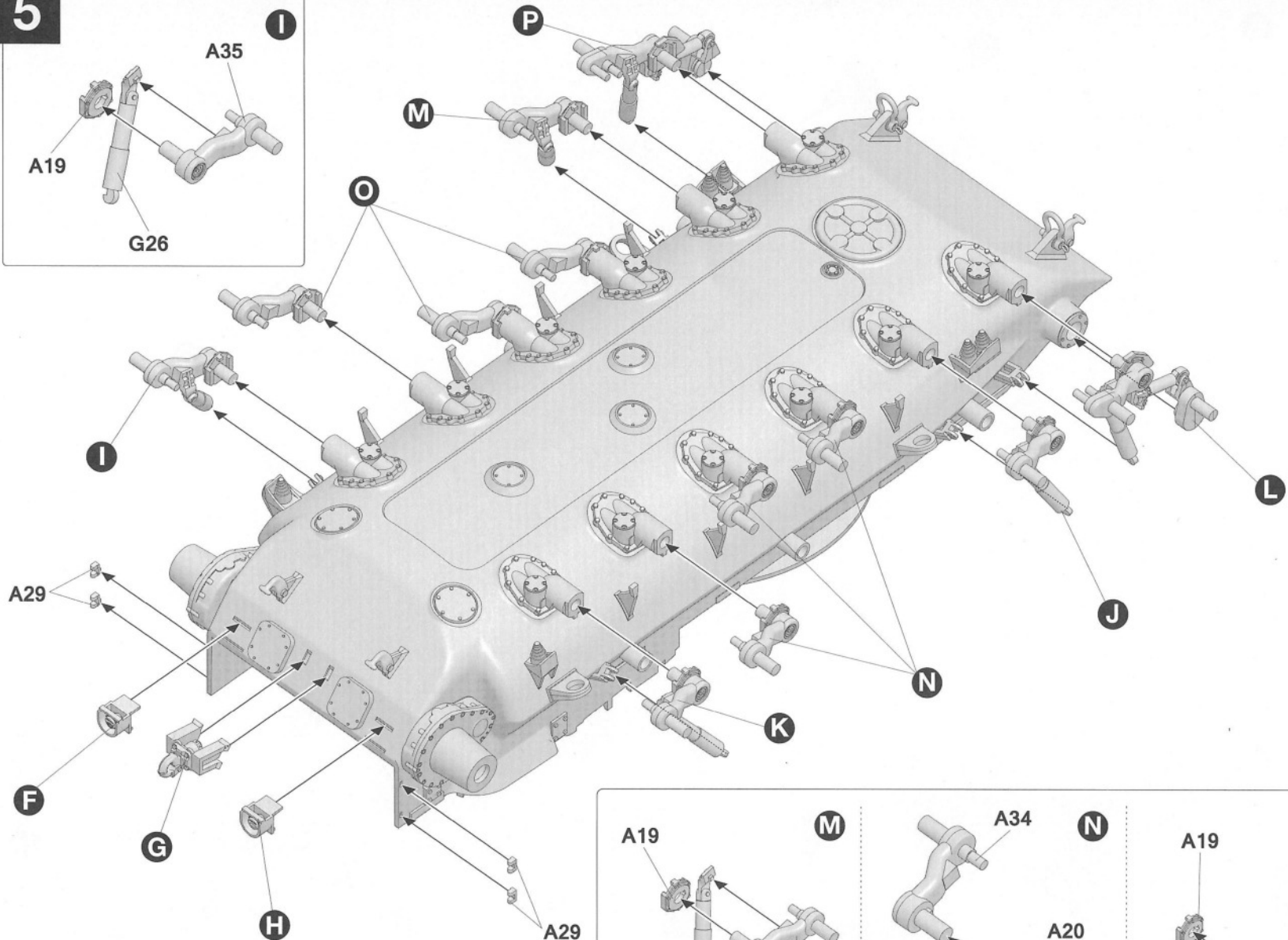
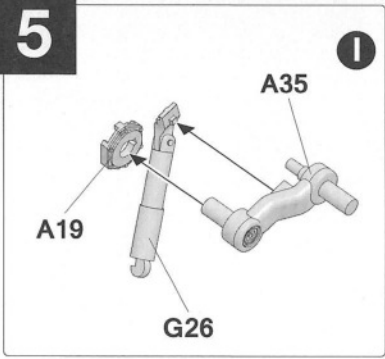

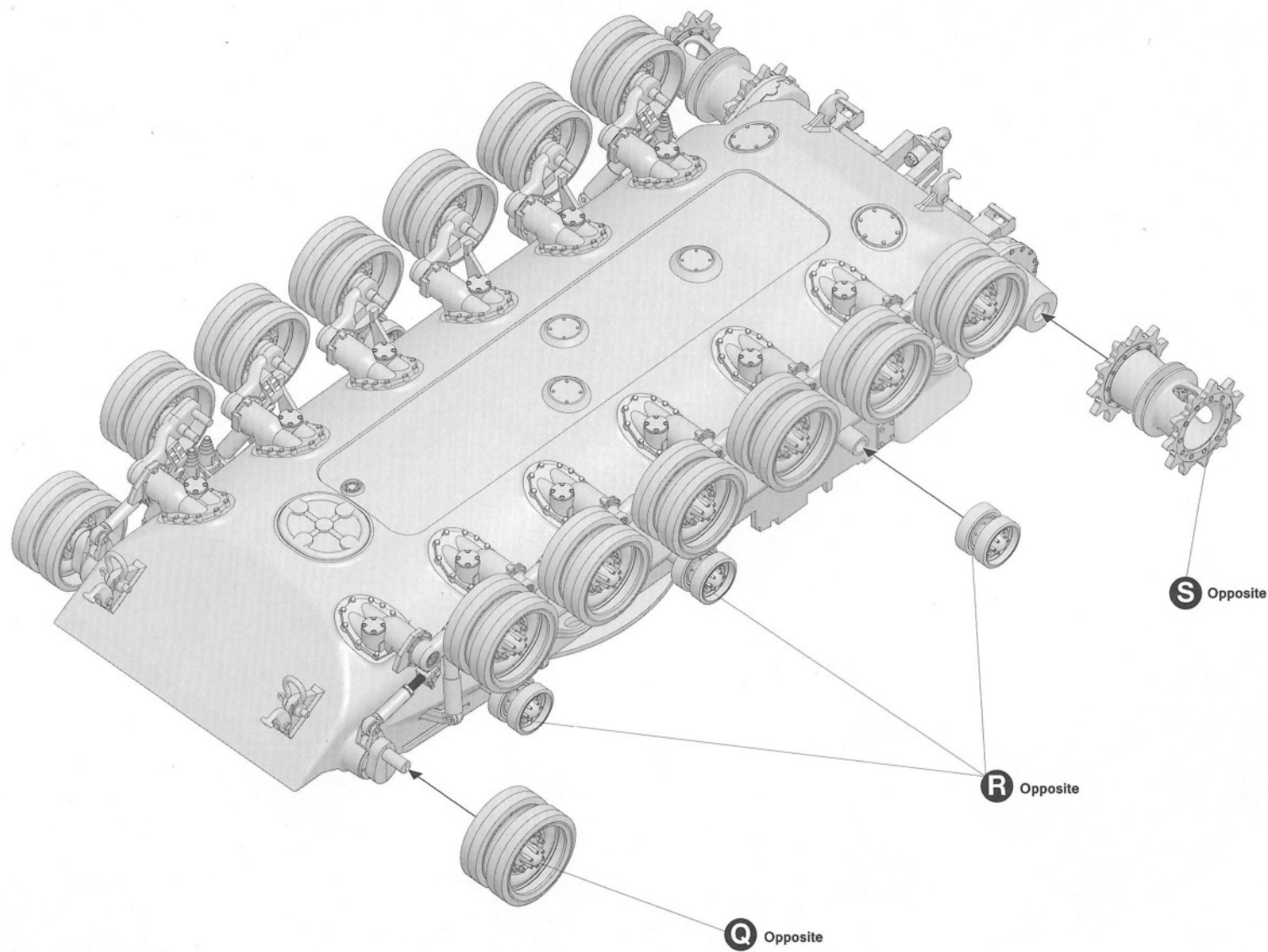

**Q**

A2

A1

A3

**Make 14**

---

**R**

A16

A13

**Make 6**

---

**S**

A12

A9

**Make 2**

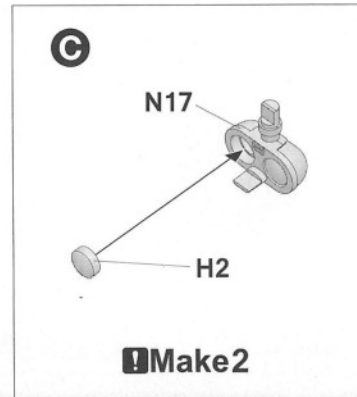
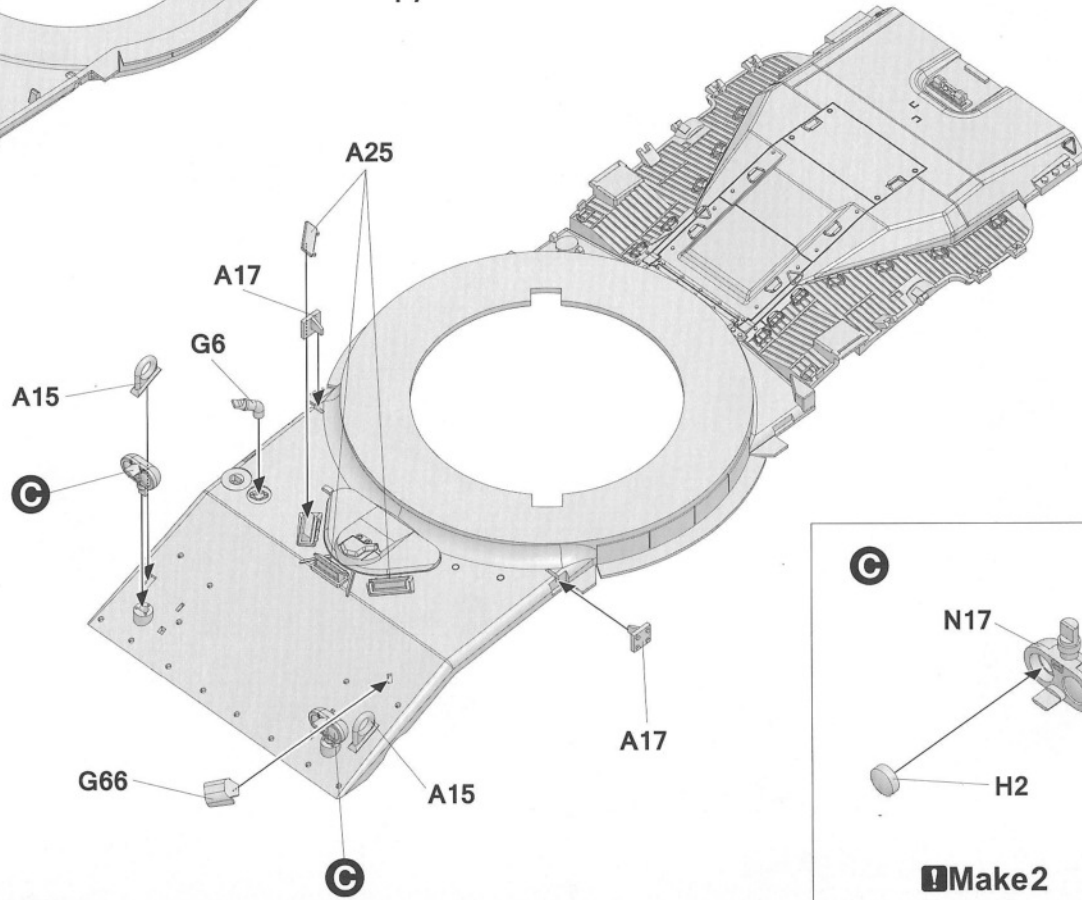
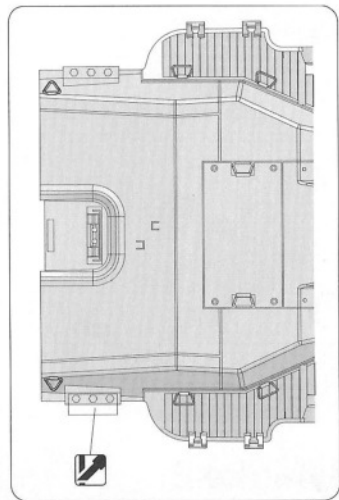
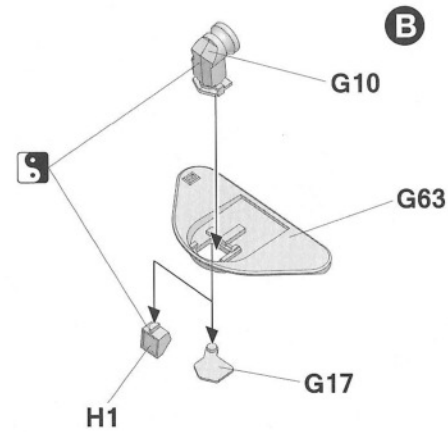
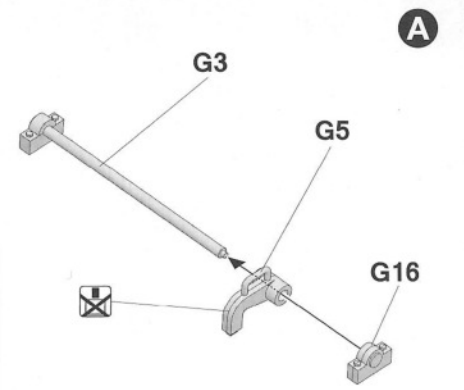
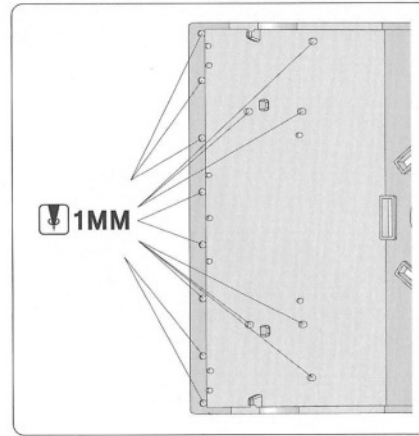
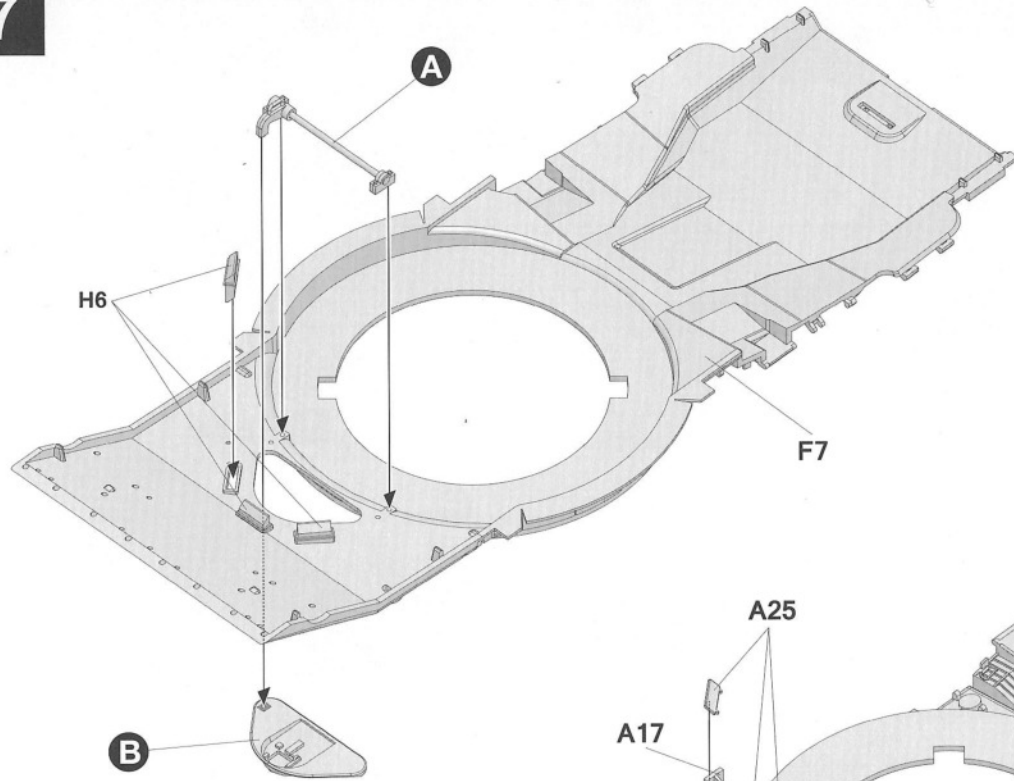

Open

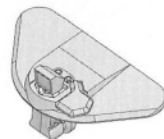

Closed





8

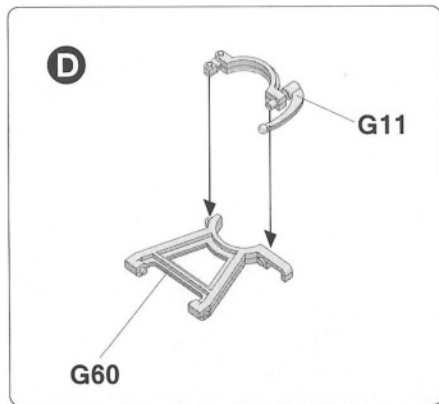
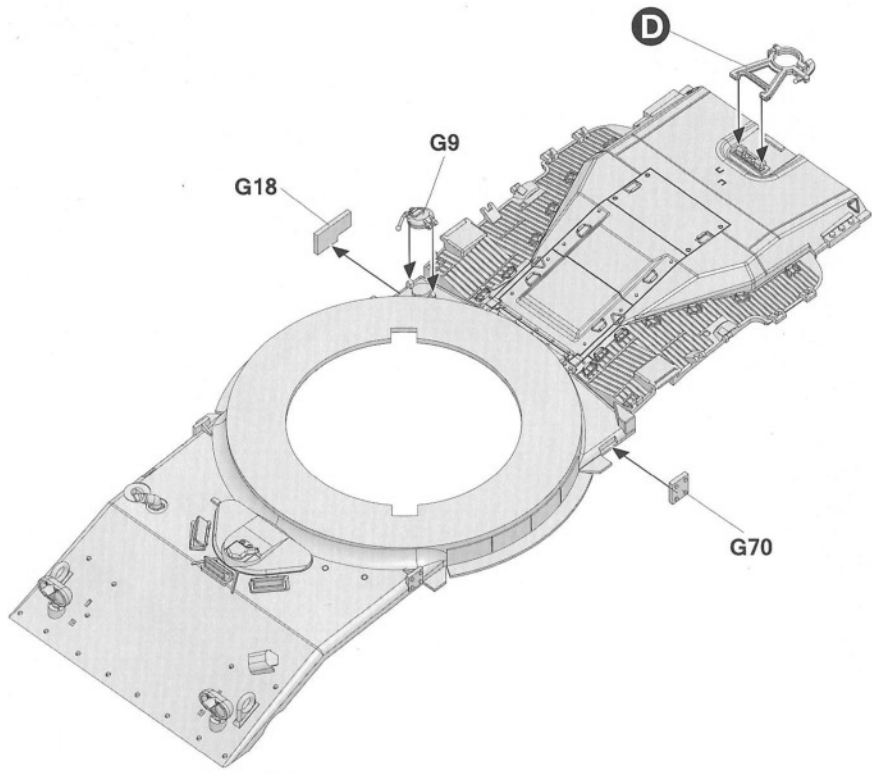

9

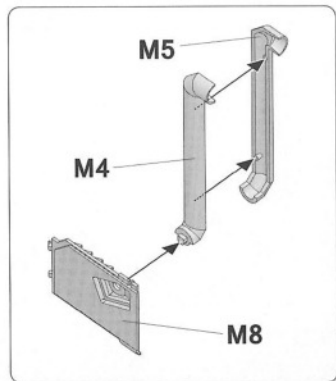
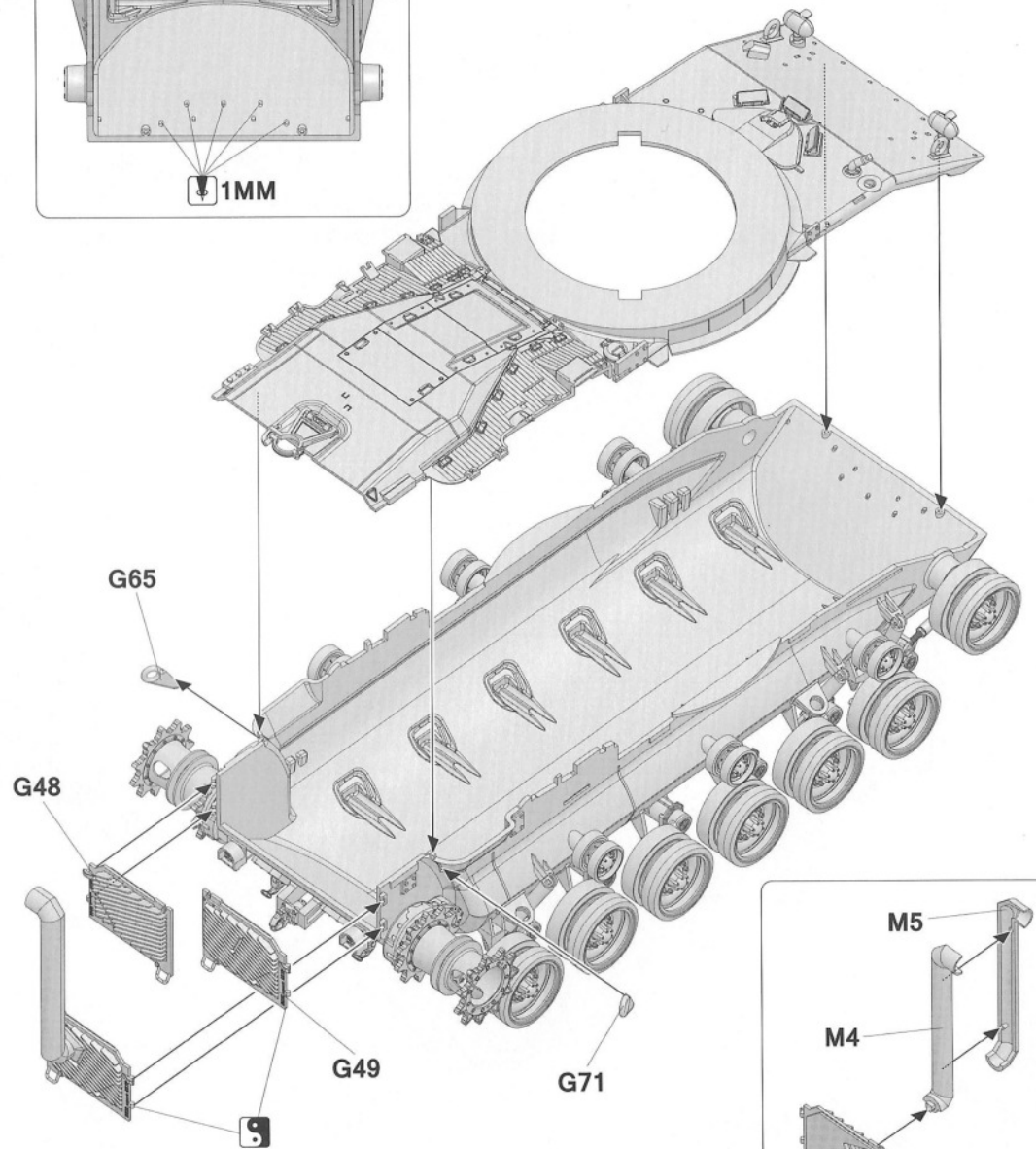
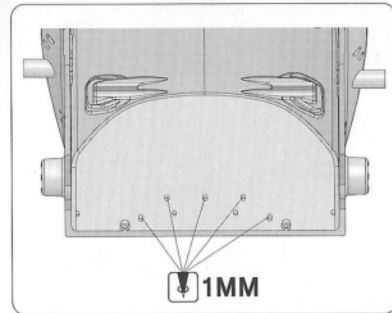

8

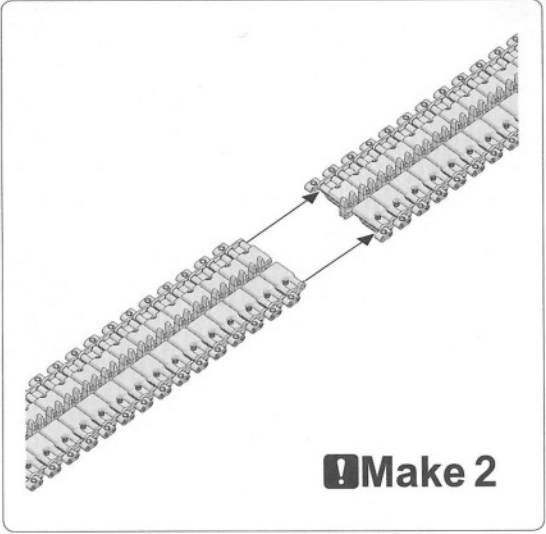
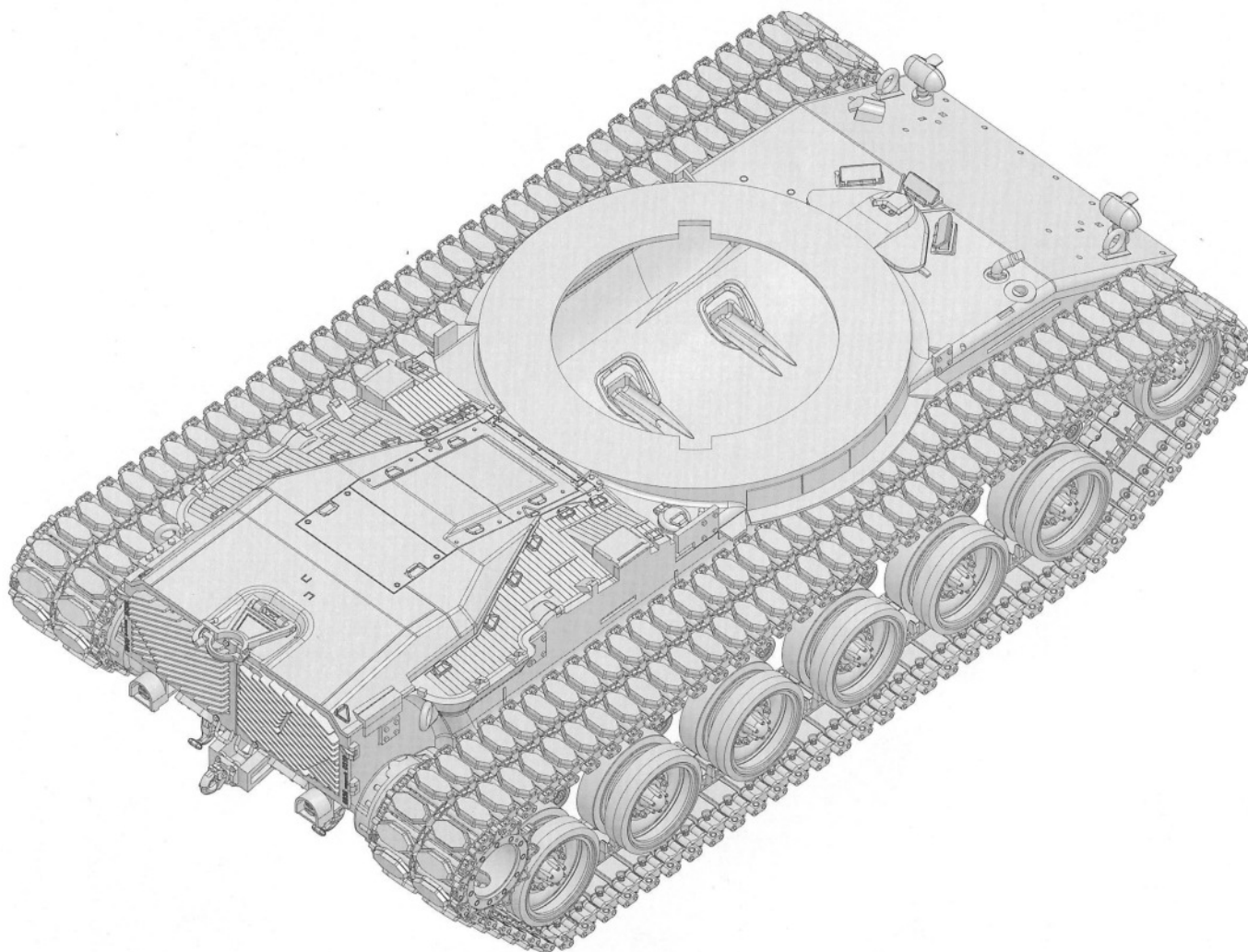

**Make 2**

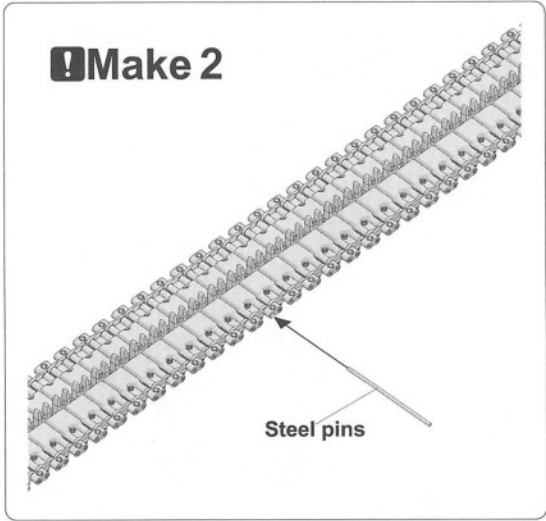

**Make 2**

Steel pins

11

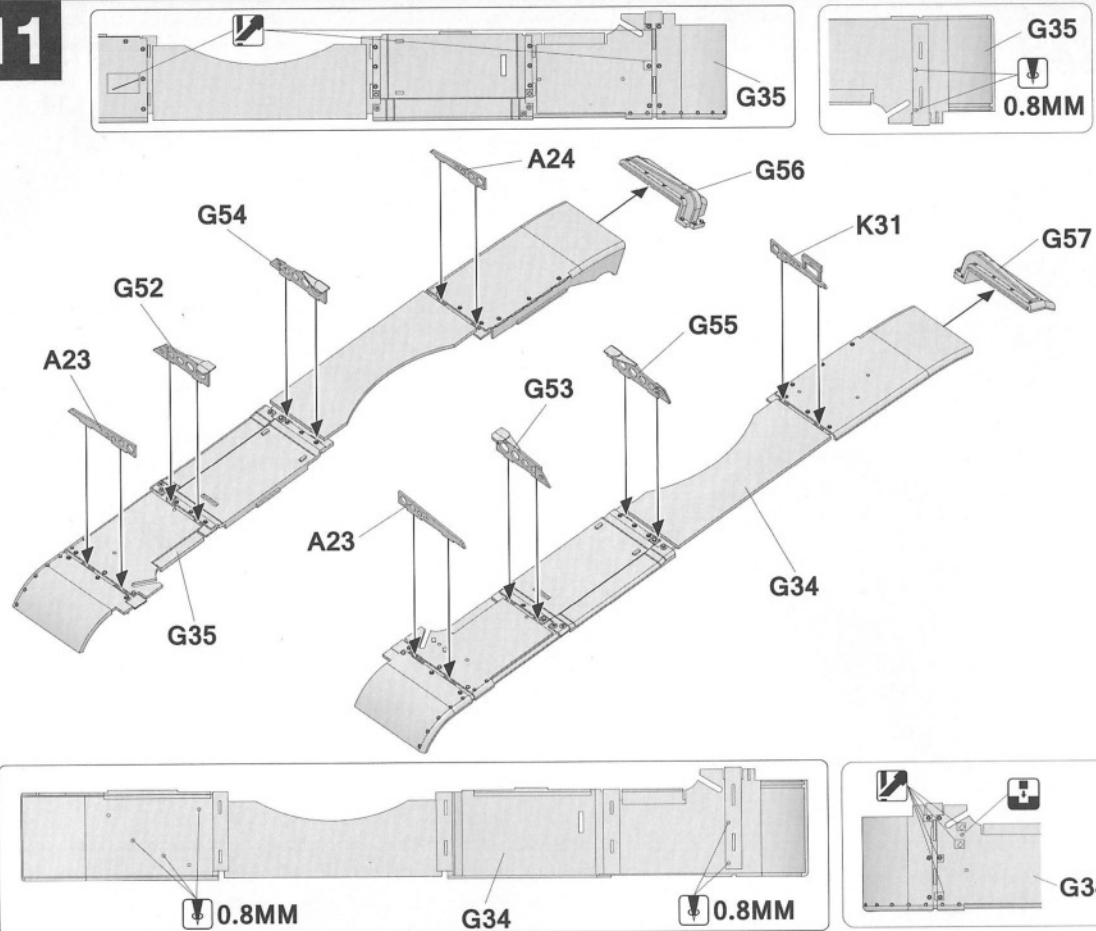

12

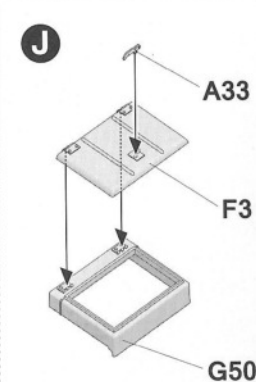
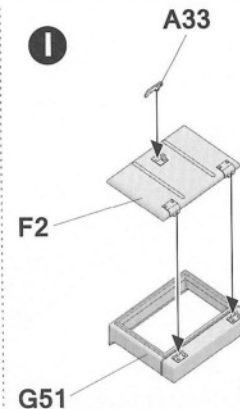
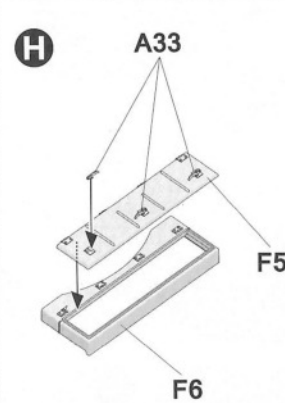
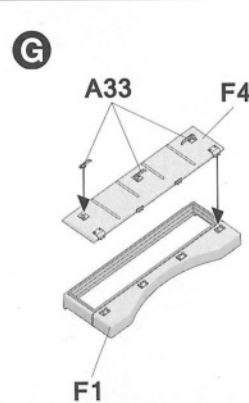
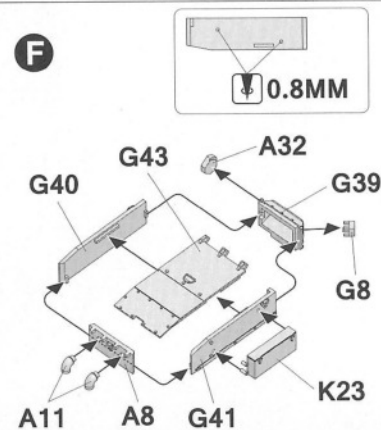
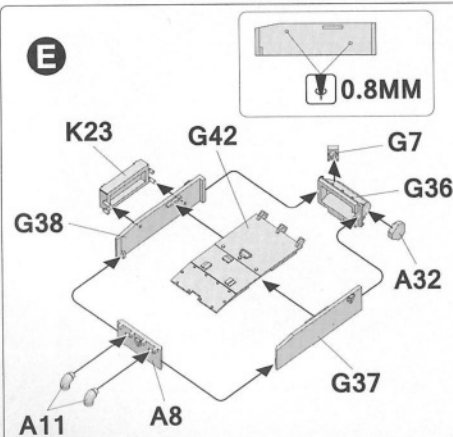
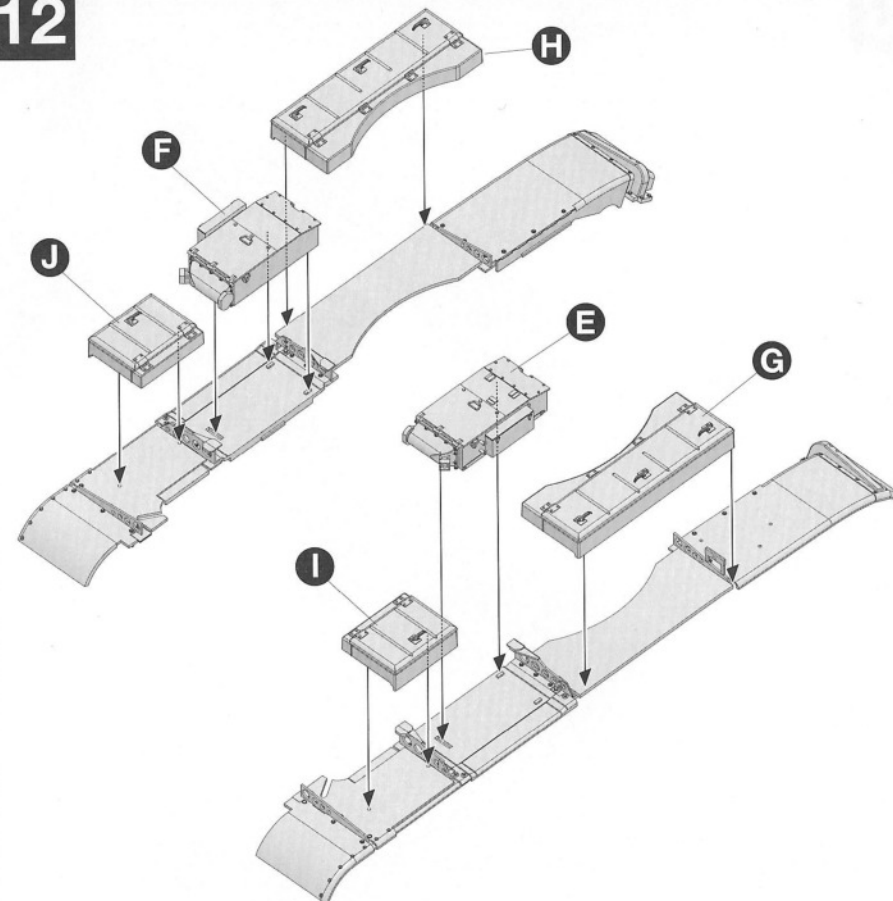

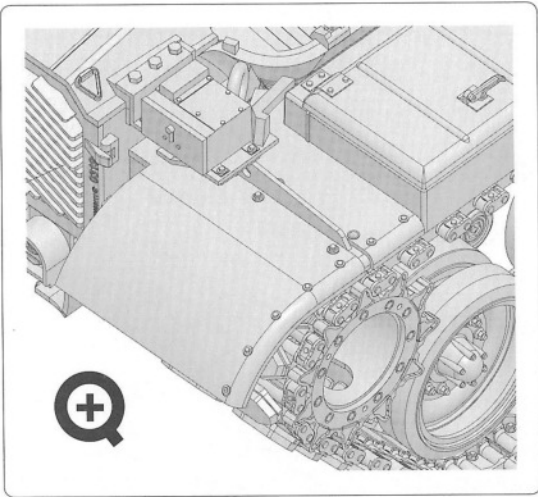
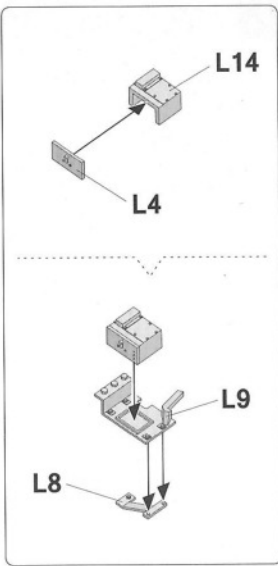
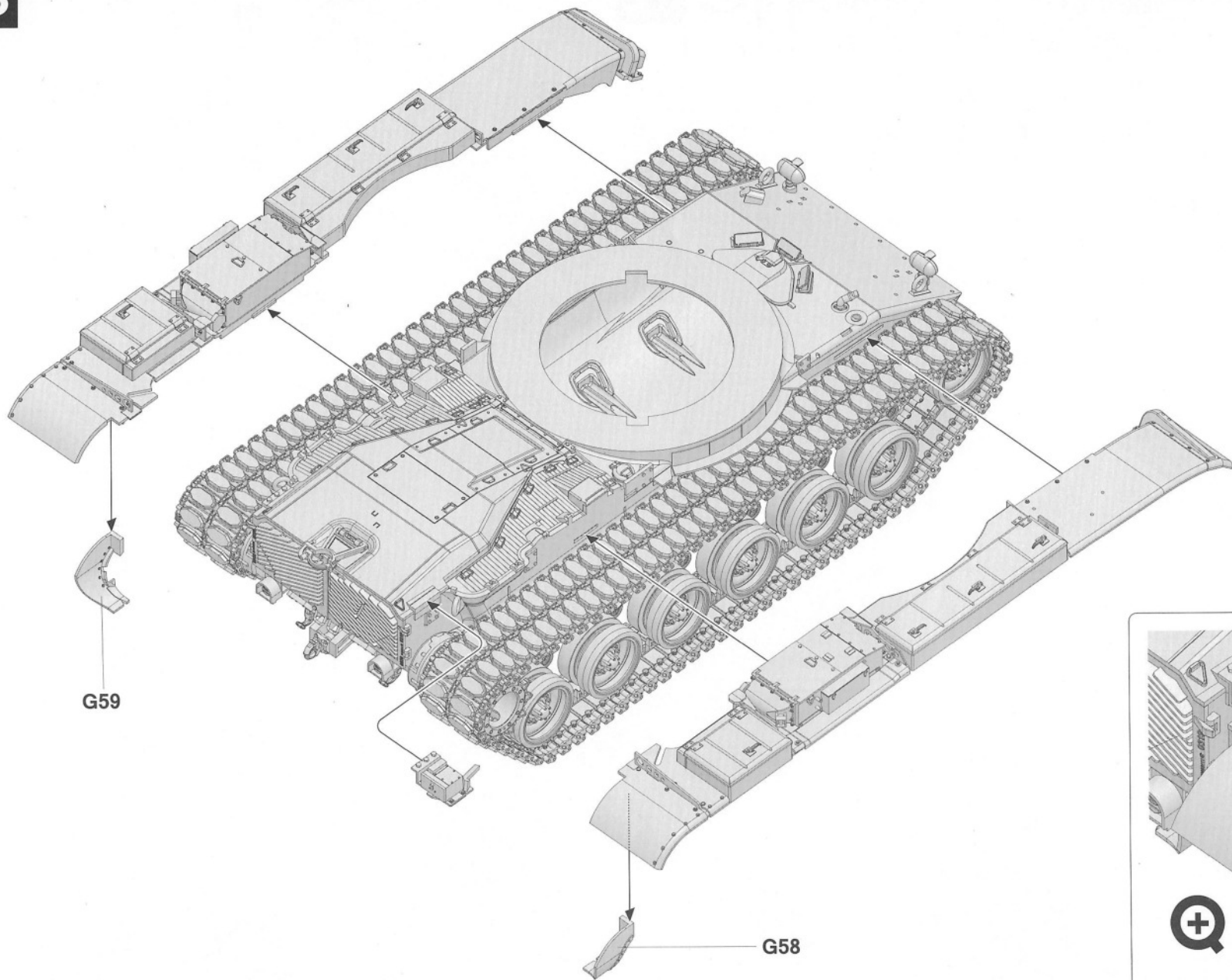

14

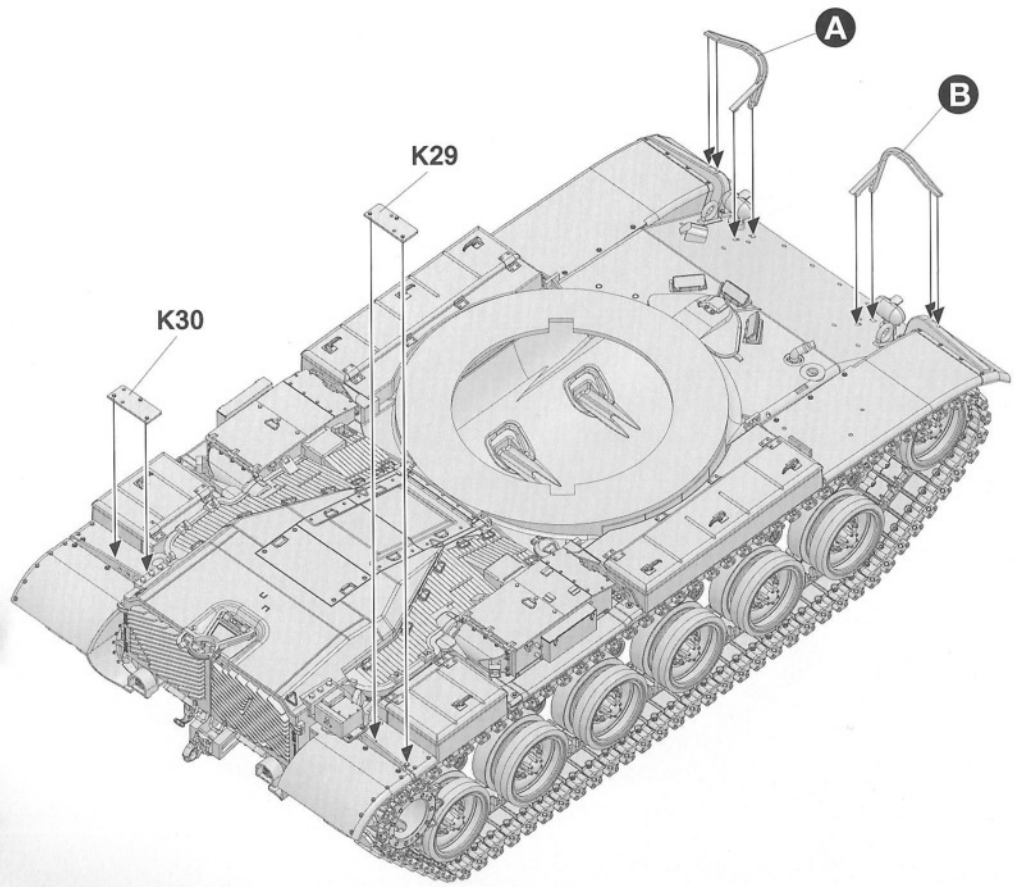
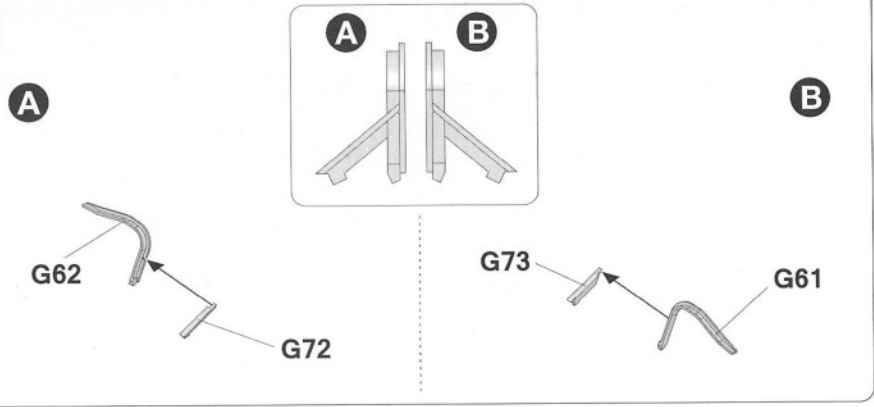

15

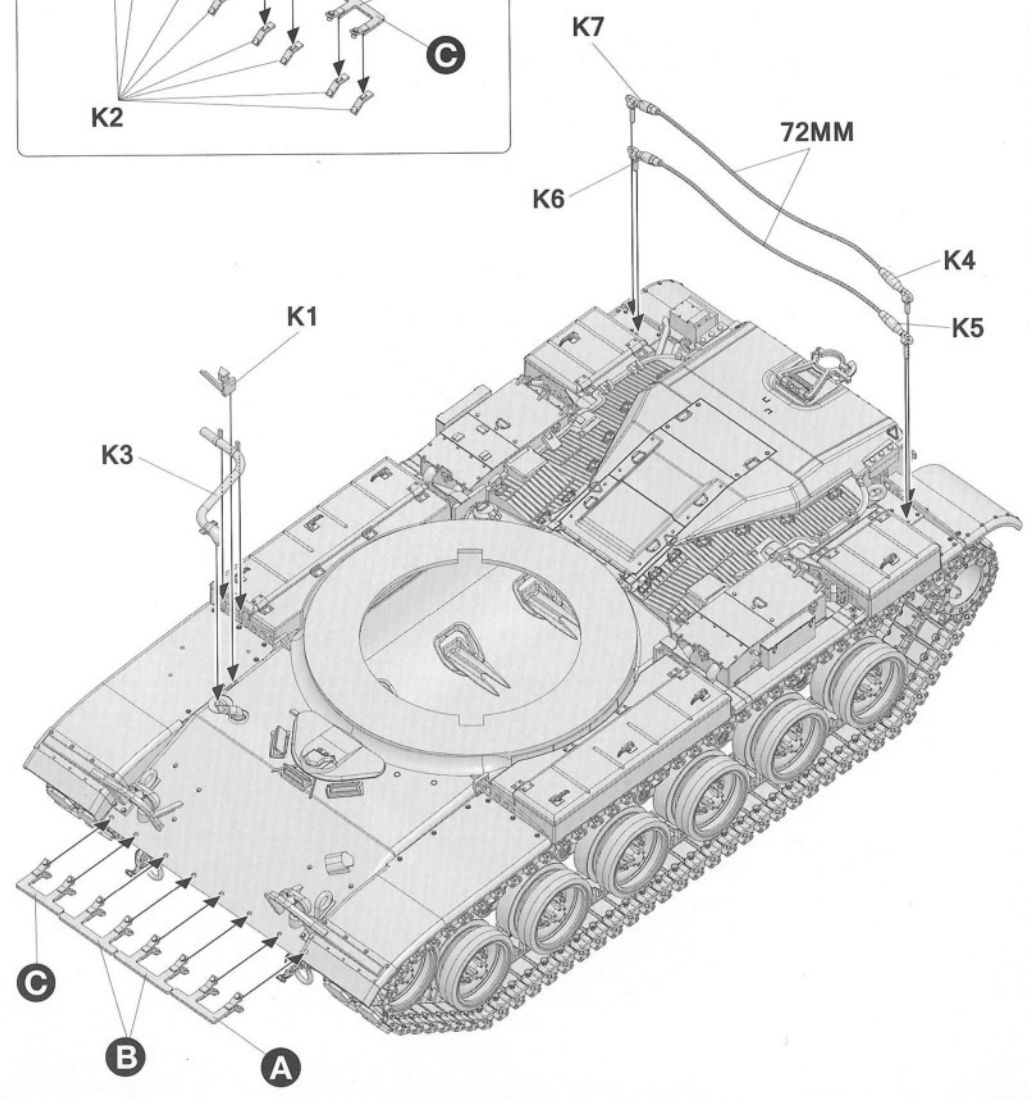
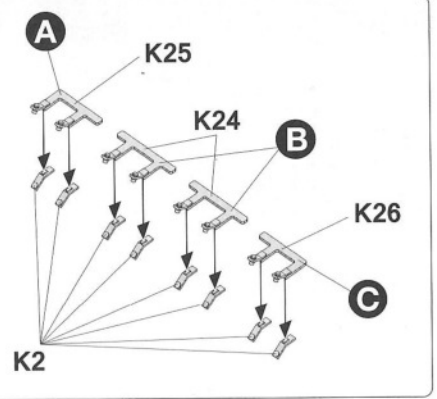

16

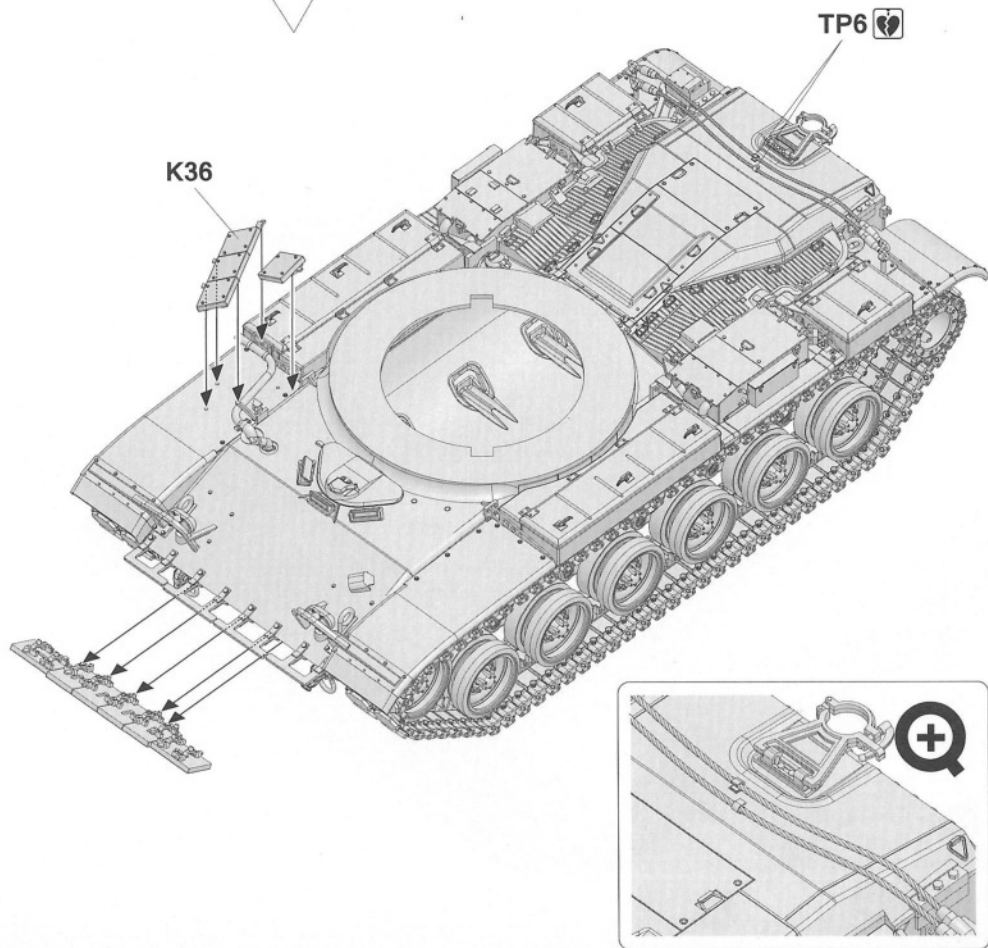
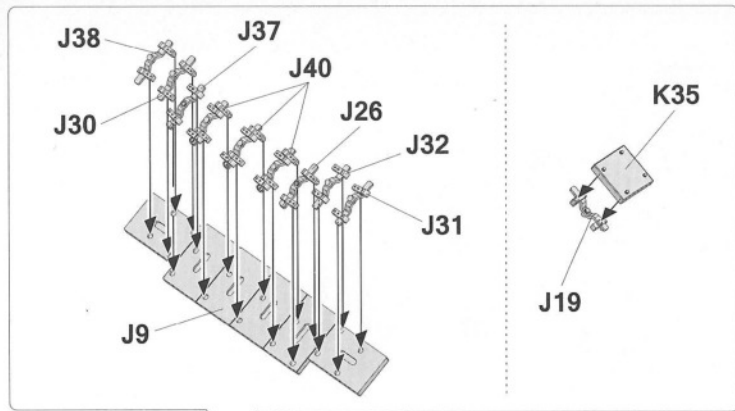

17

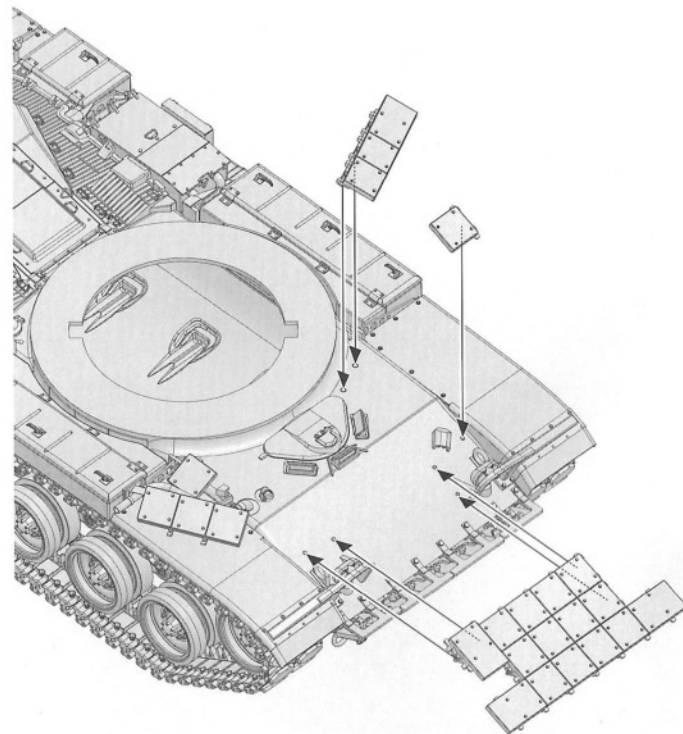
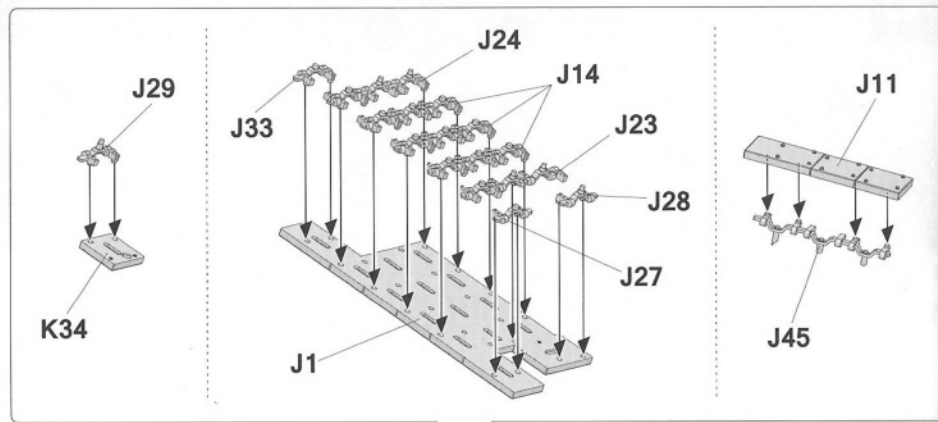

18

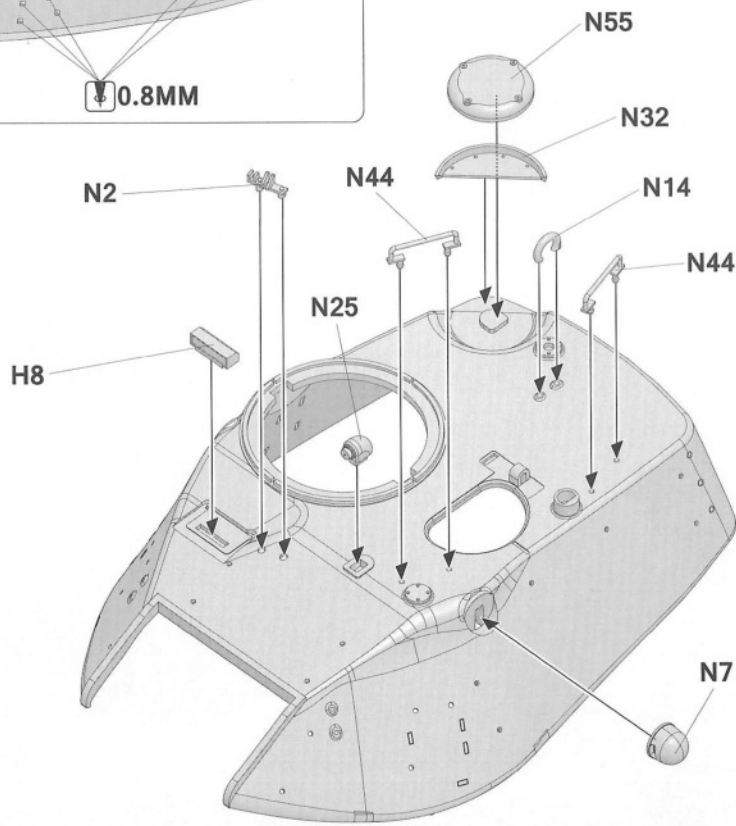
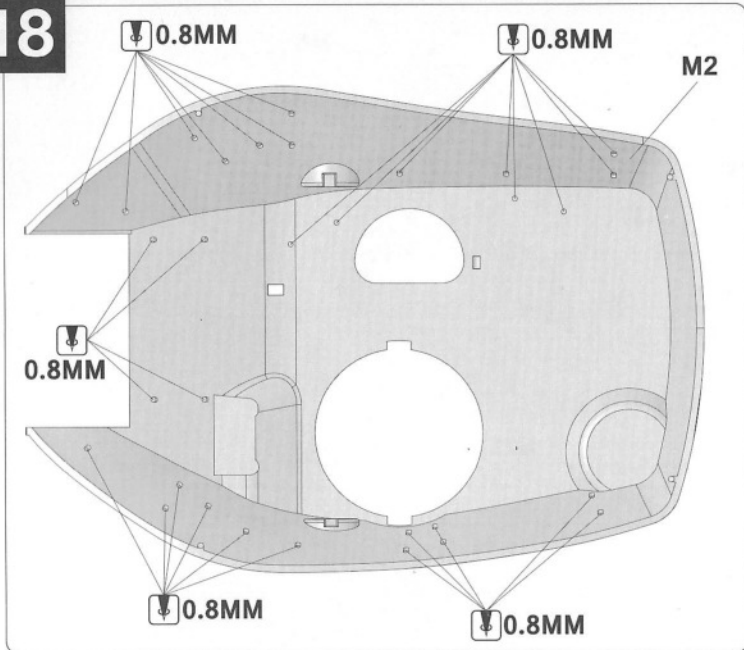

19

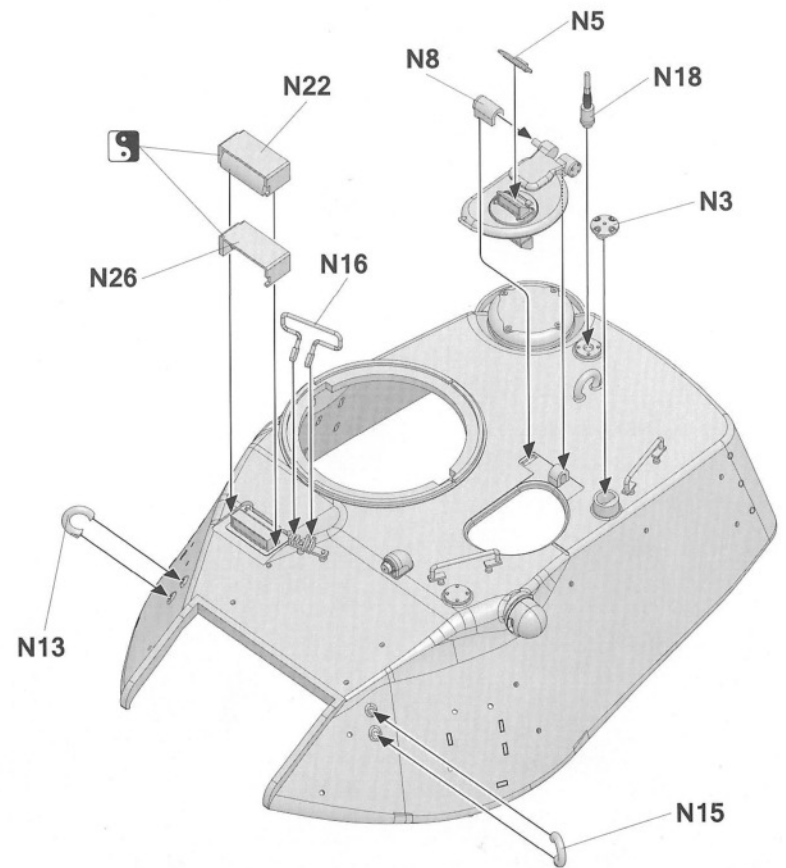
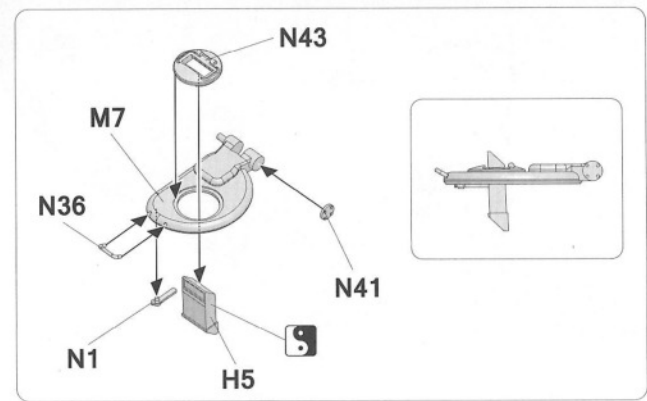

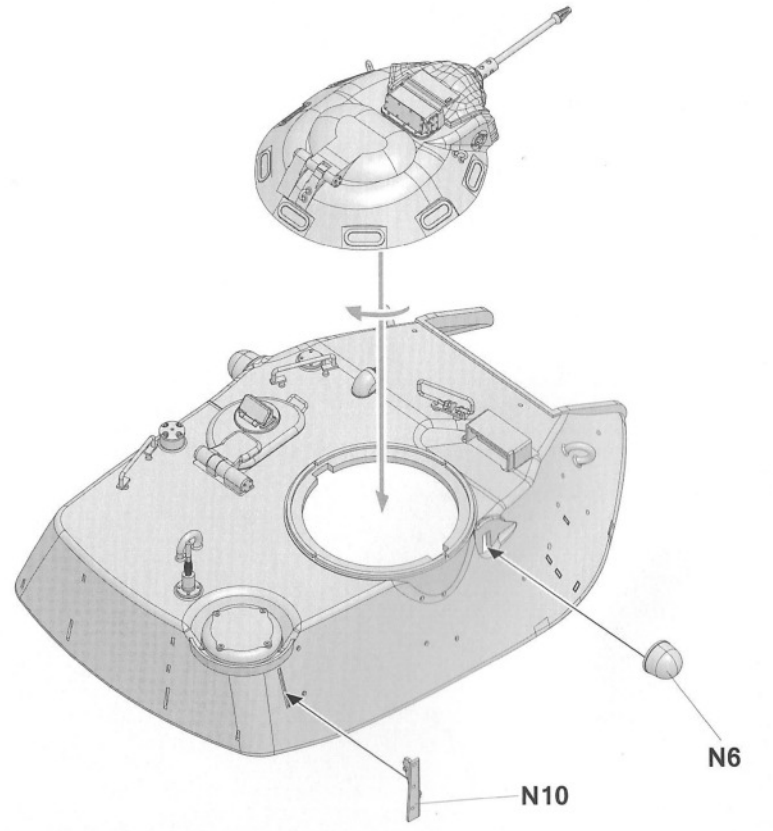
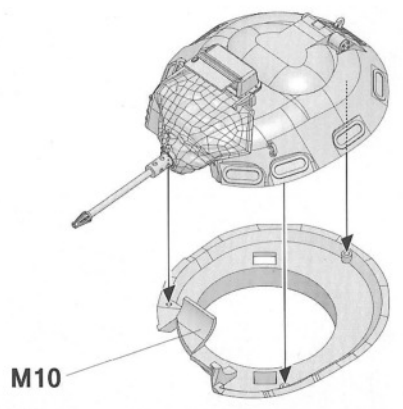
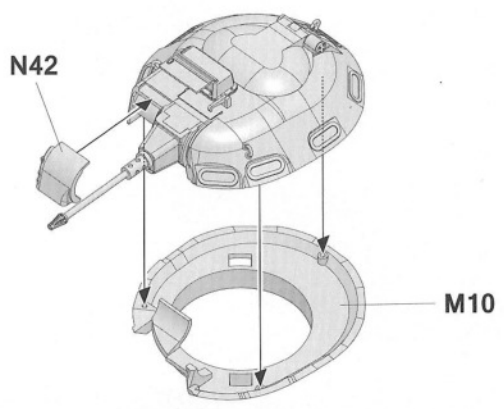
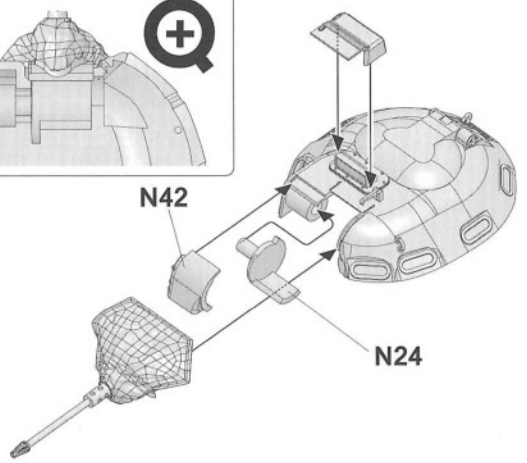
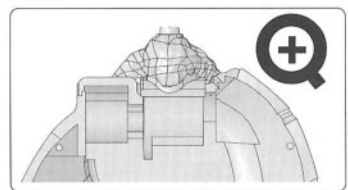
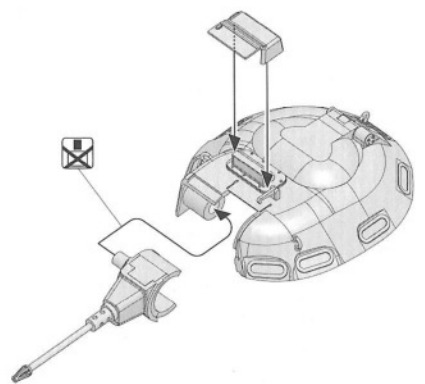
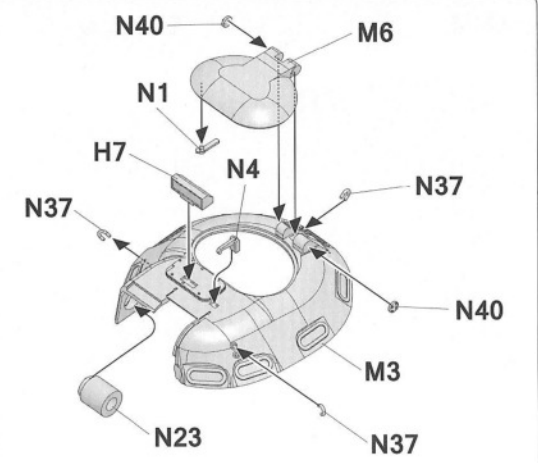
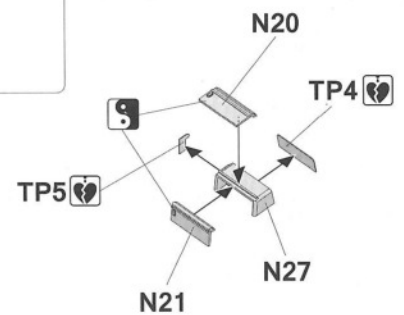
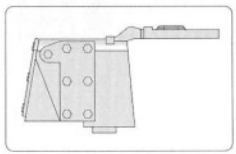
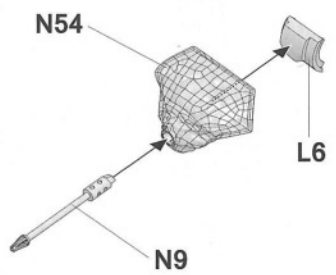
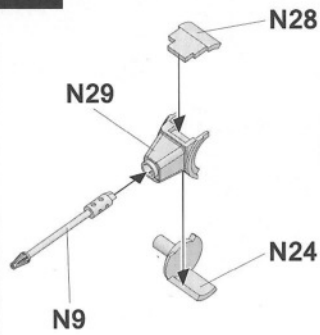



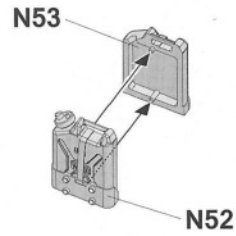
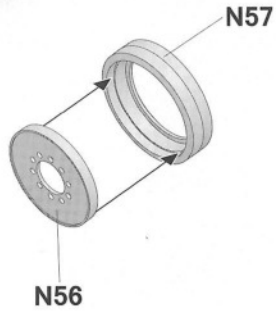

**Make 2**

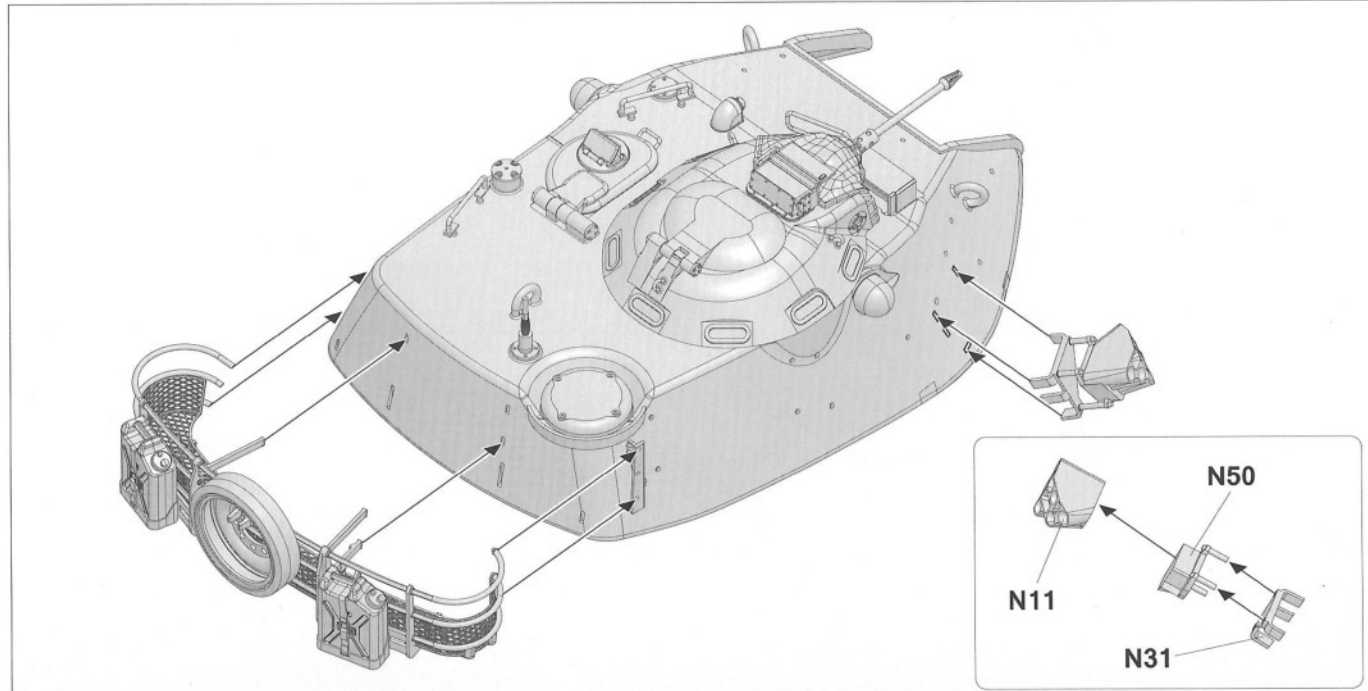
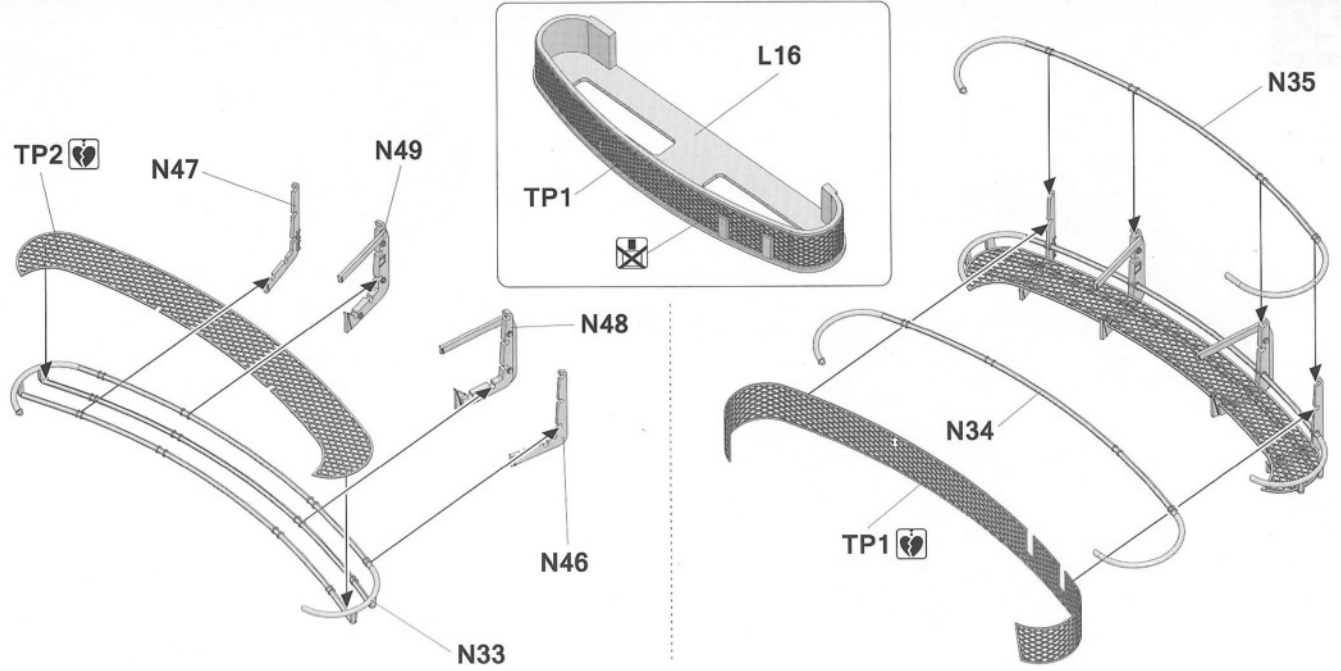
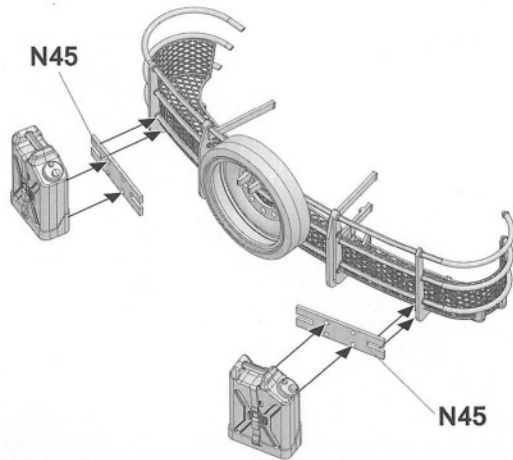
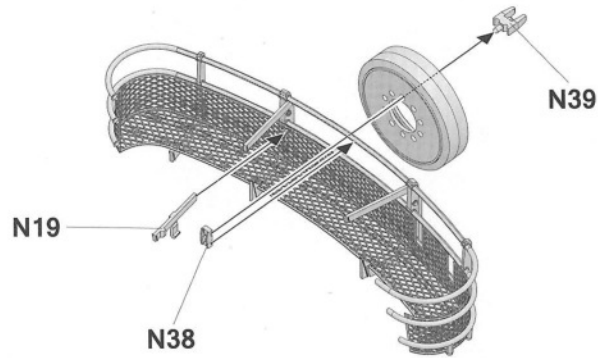

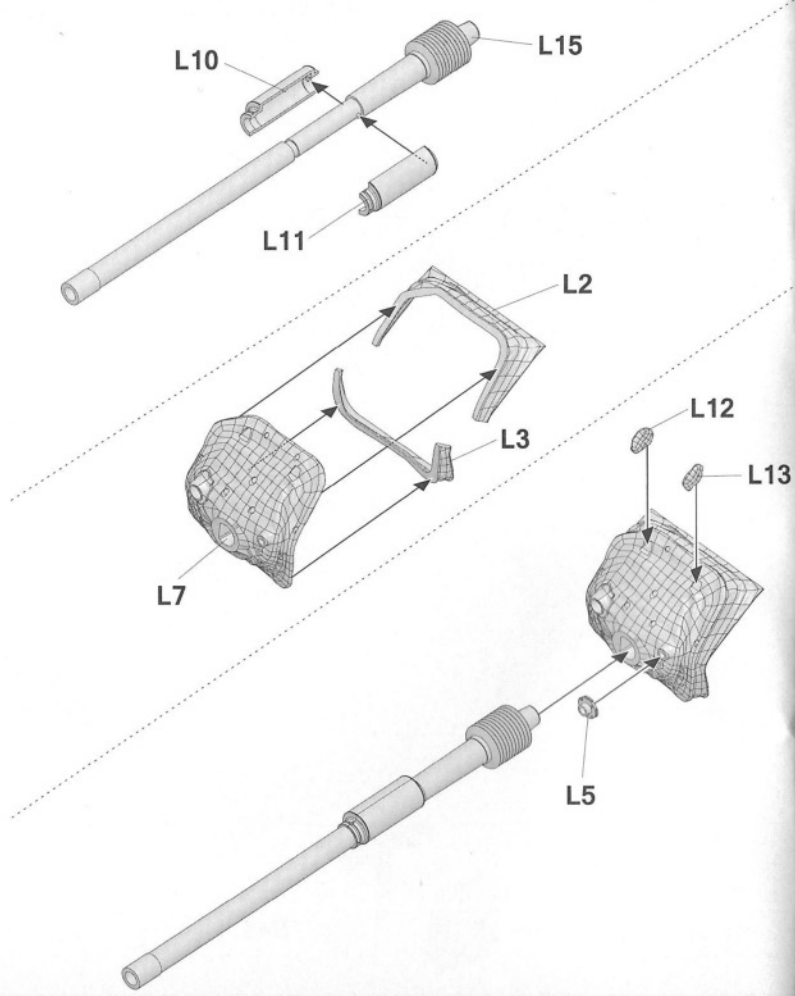
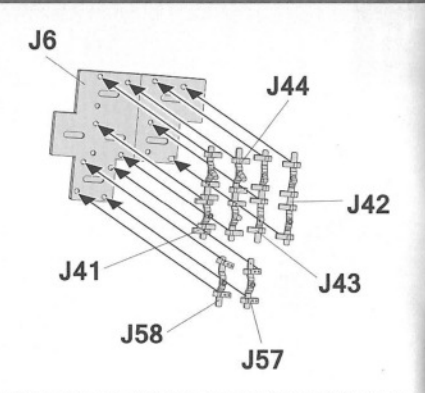
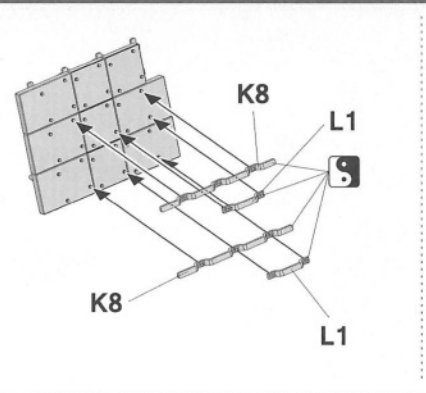
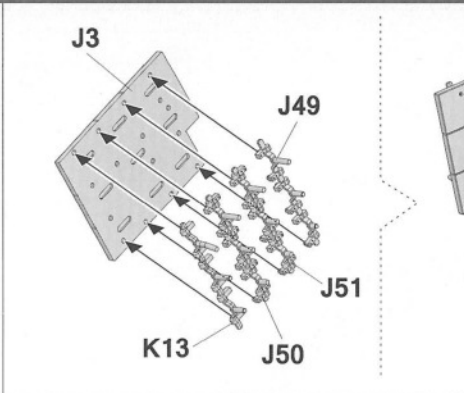
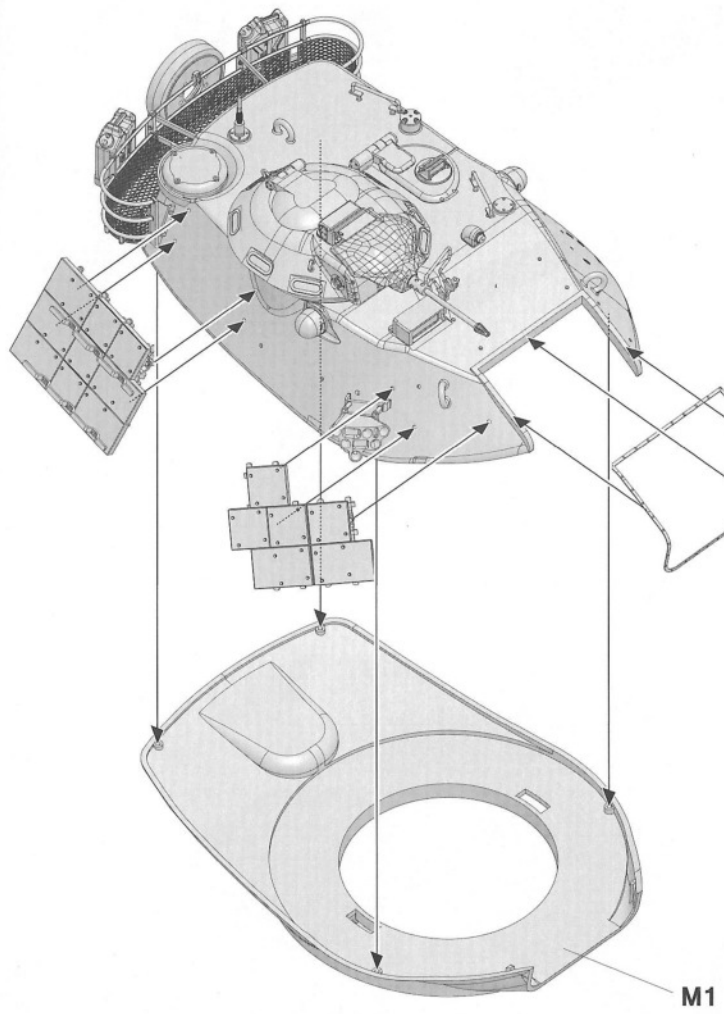

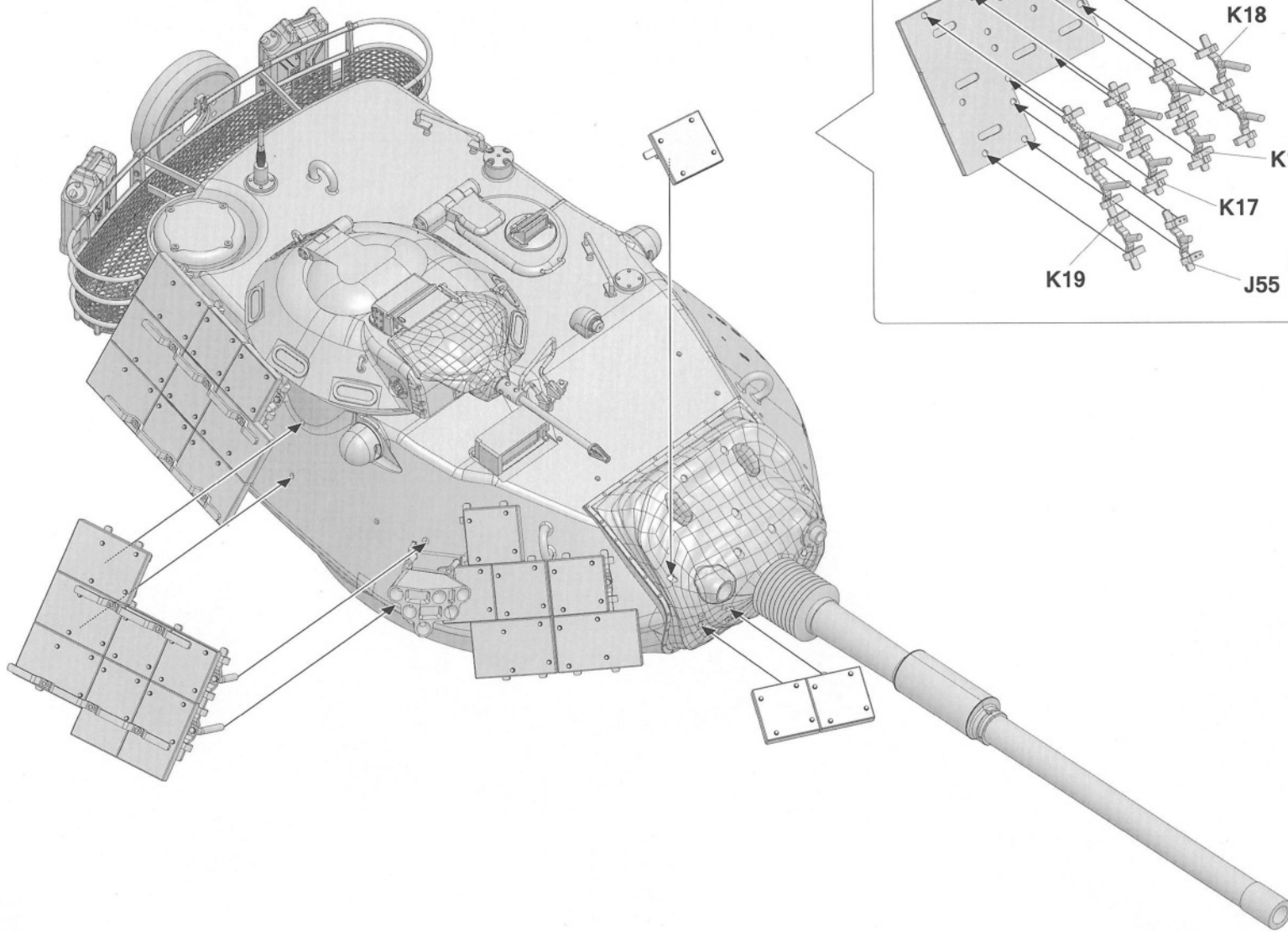

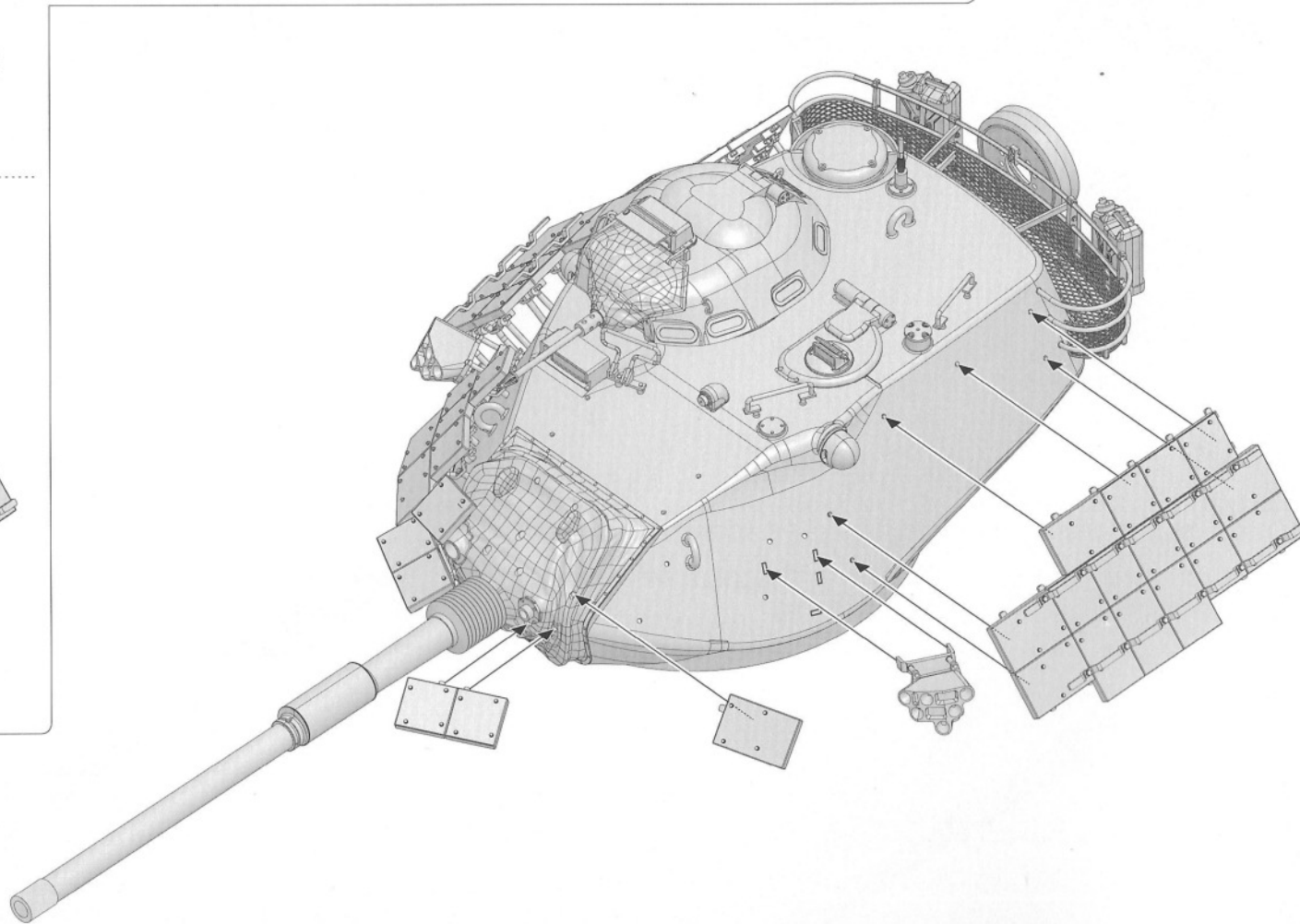
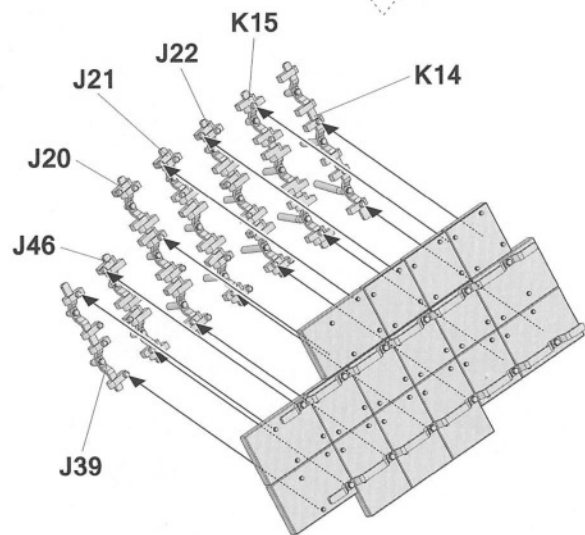
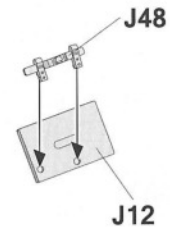
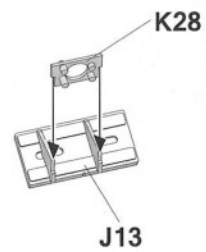
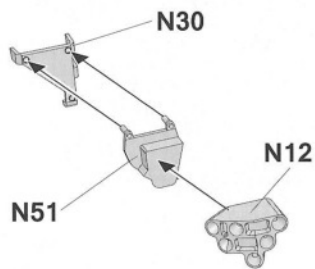
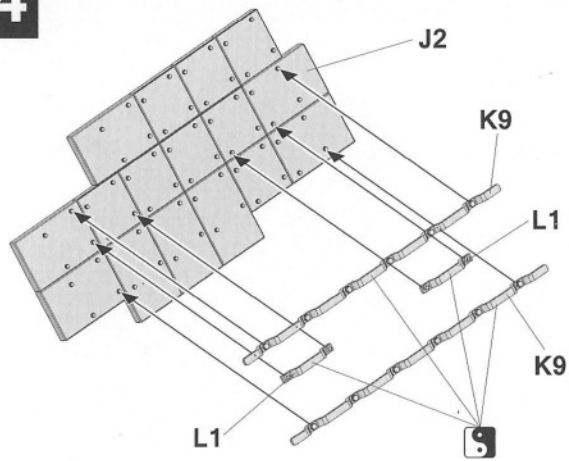

25

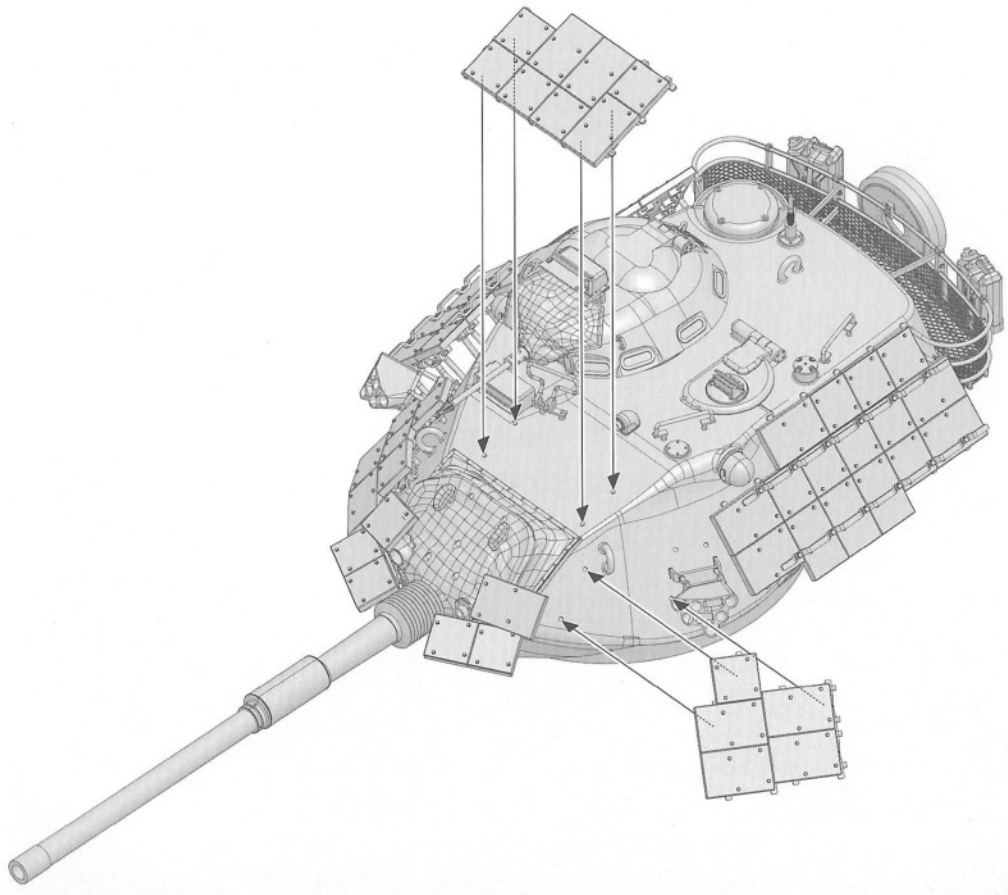
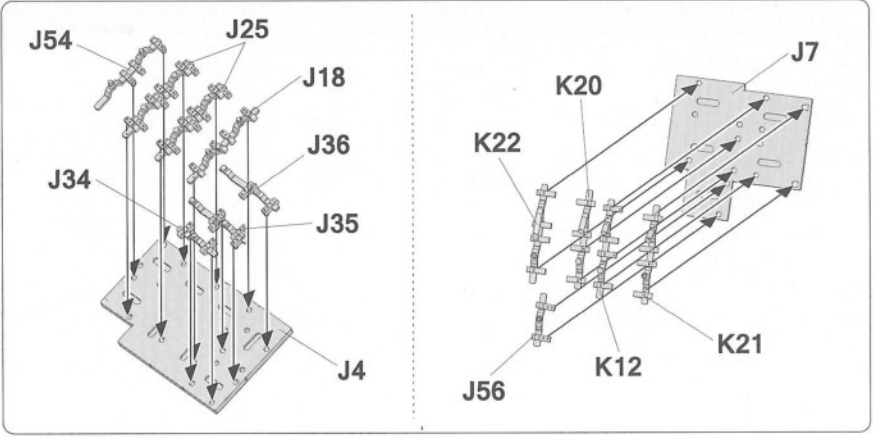

26

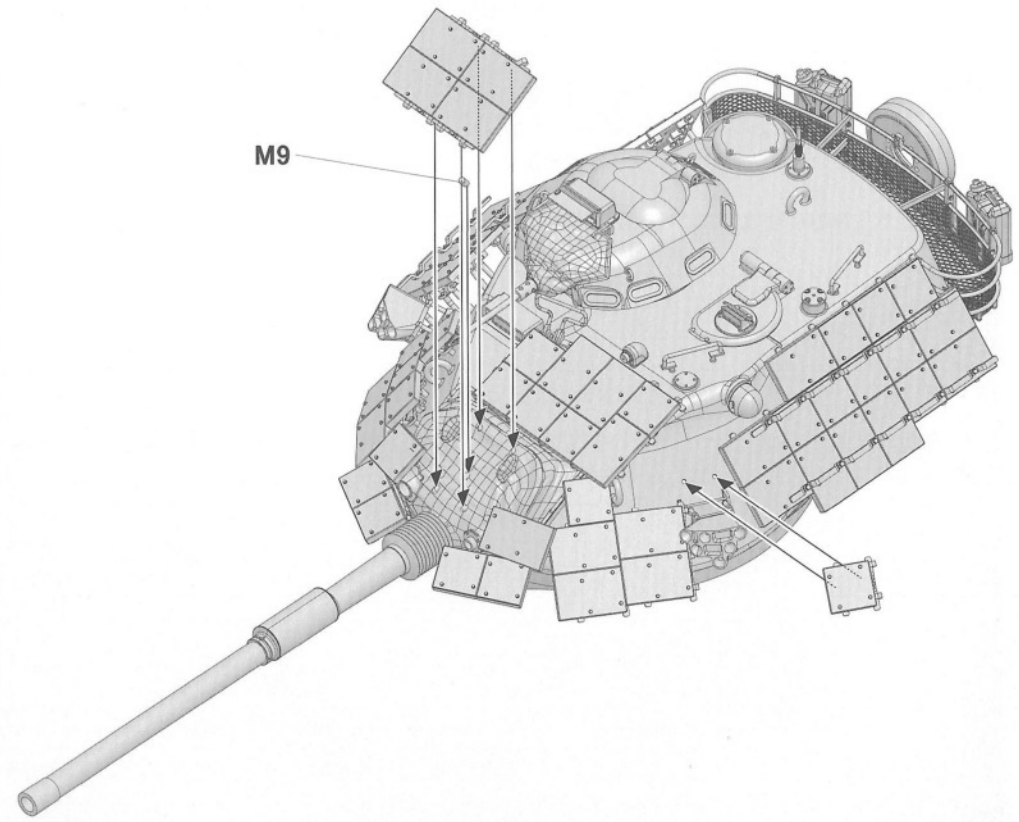
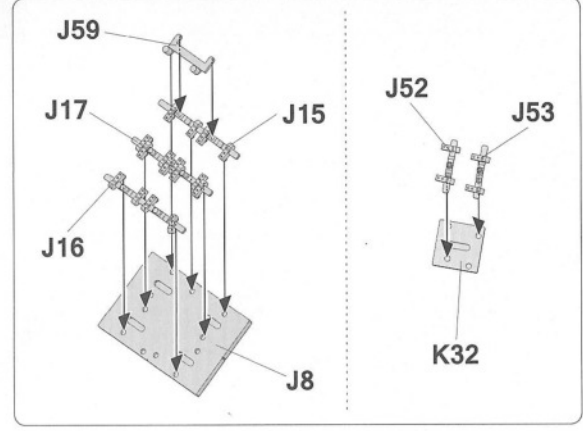

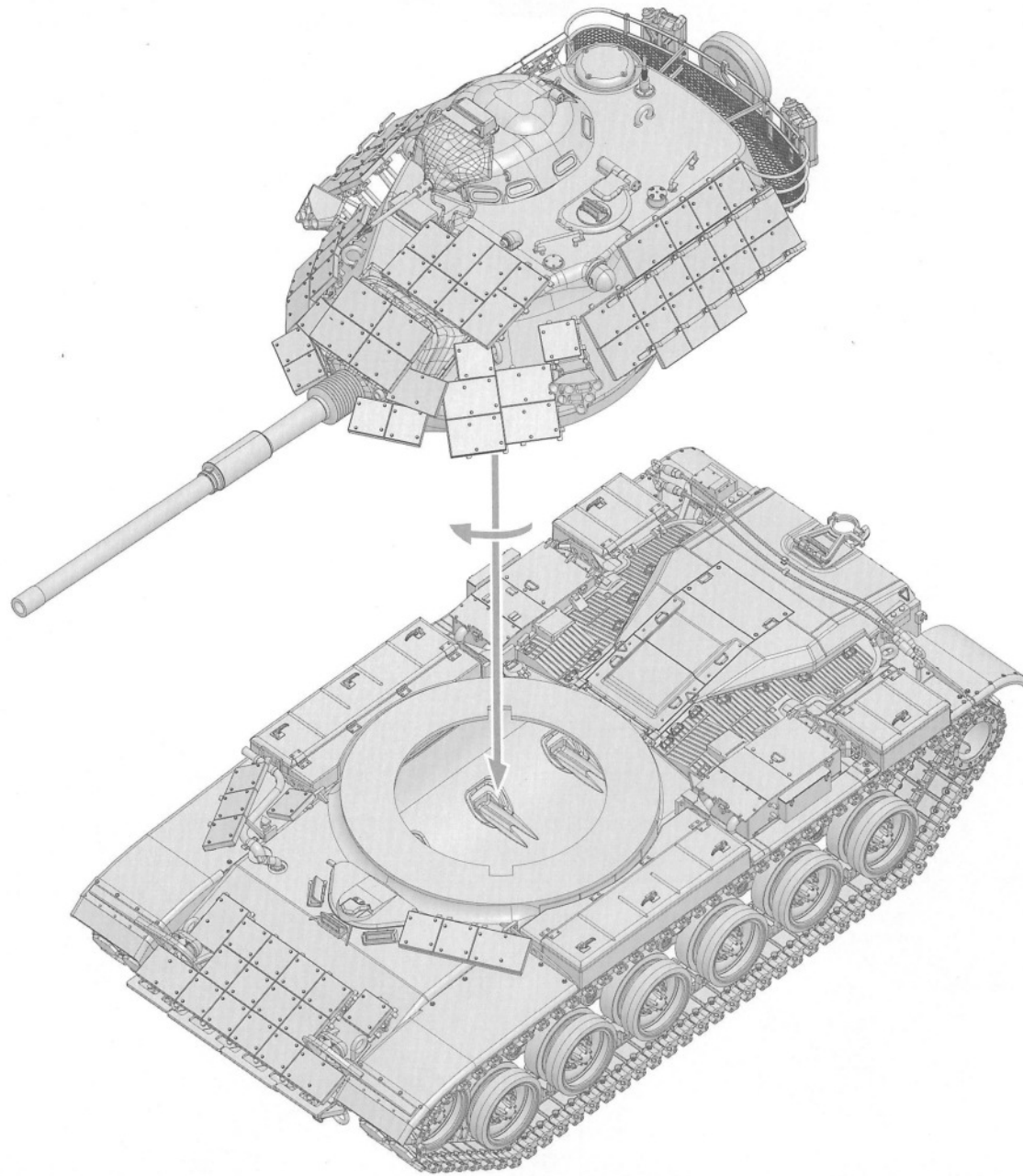

03.03.2113



# USMC M60 A1

www.migjimenez.com



03.03.2113



# USMC M60 A1

www.migjimenez.com



## Painting and Marking Guide

**TAKOM** Ref: 2113

1/35 U.S Marine main battle tank

3 rd Platoon, Alpha Company, 8 th Tank Battalion  
USMC, Operation Desert Storm 1991.

<b>A.MIG 033</b> Rubber & Tires	<b>A.MIG 035</b> Dark Tracks	<b>A.MIG 045</b> Gun Metal	<b>A.MIG 071</b> Khaki
<b>A.MIG 094</b> Crystal Glass	<b>A.MIG 095</b> Crystal Smoke	<b>A.MIG 099</b> Crystal Black Blue	<b>A.MIG 195</b> Silver
<b>A.MIG 025</b> U.S Modern Vehicles	<b>A.MIG 046</b> Matt Black		

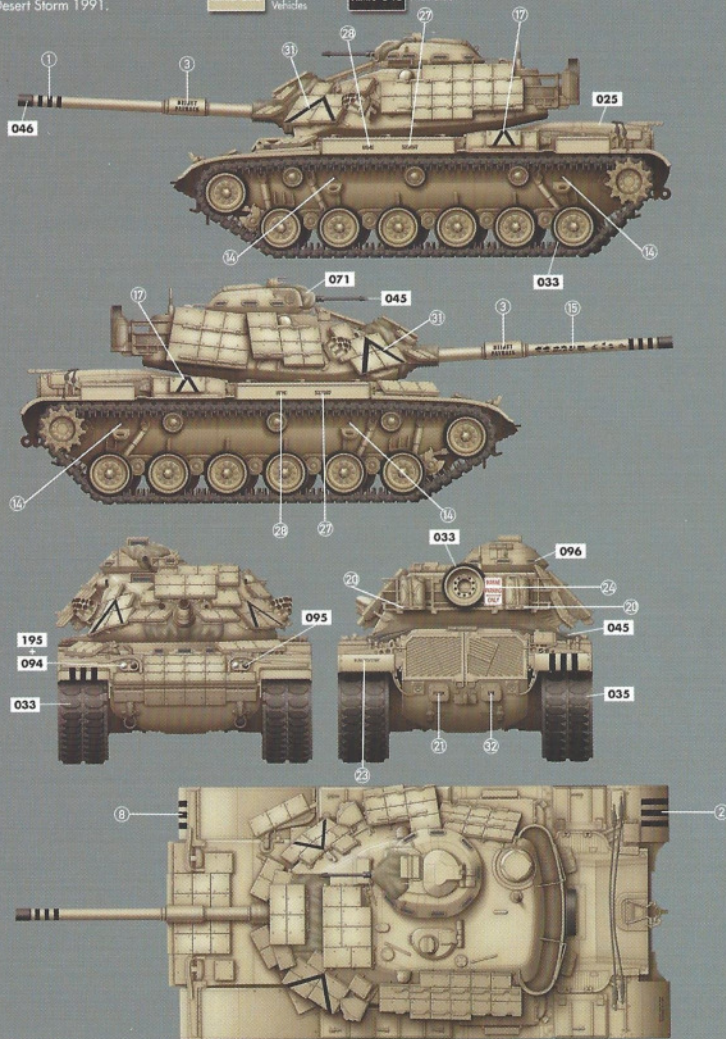

### WEATHERING STEPS WITH AMMO PRODUCTS

<b>1</b> GENERAL WASH A.MIG-1007 U.S Modern Vehicle Wash	<b>3</b> STREAKING A.MIG-1207 Streaking Grime for US Modern Vehicles	<b>5</b> DUST A.MIG-3018 Middle East Dust	<b>7</b> HEAVY MUD A.MIG-1701 Thick Soil
<b>2</b> FILTER A.MIG-1503 Ochre for Light Sand	<b>4</b> TRACK WASH A.MIG-1002 Tracks Wash	<b>6</b> SPLASHES A.MIG-1750 Dry Earth	<b>8</b> GREASE & OIL A.MIG-1408 Fresh Engine Oil

## Painting and Marking Guide

**TAKOM** Ref: 2113

1/35 U.S Marine main battle tank

C-14, 1 st Platoon, Charlie Company, 3 rd Tank  
Battalion USMC, Regimental Combat Team-7,  
Task Force Ripper, Operation Desert Storm 1991.

<b>A.MIG 033</b> Rubber & Tires	<b>A.MIG 035</b> Dark Tracks	<b>A.MIG 045</b> Gun Metal	<b>A.MIG 071</b> Khaki
<b>A.MIG 094</b> Crystal Glass	<b>A.MIG 095</b> Crystal Smoke	<b>A.MIG 099</b> Crystal Black Blue	<b>A.MIG 195</b> Silver
<b>A.MIG 025</b> U.S Modern Vehicles	<b>A.MIG 046</b> Matt Black	<b>A.MIG 072</b> Dust	<b>A.MIG 081</b> US Olive Drab

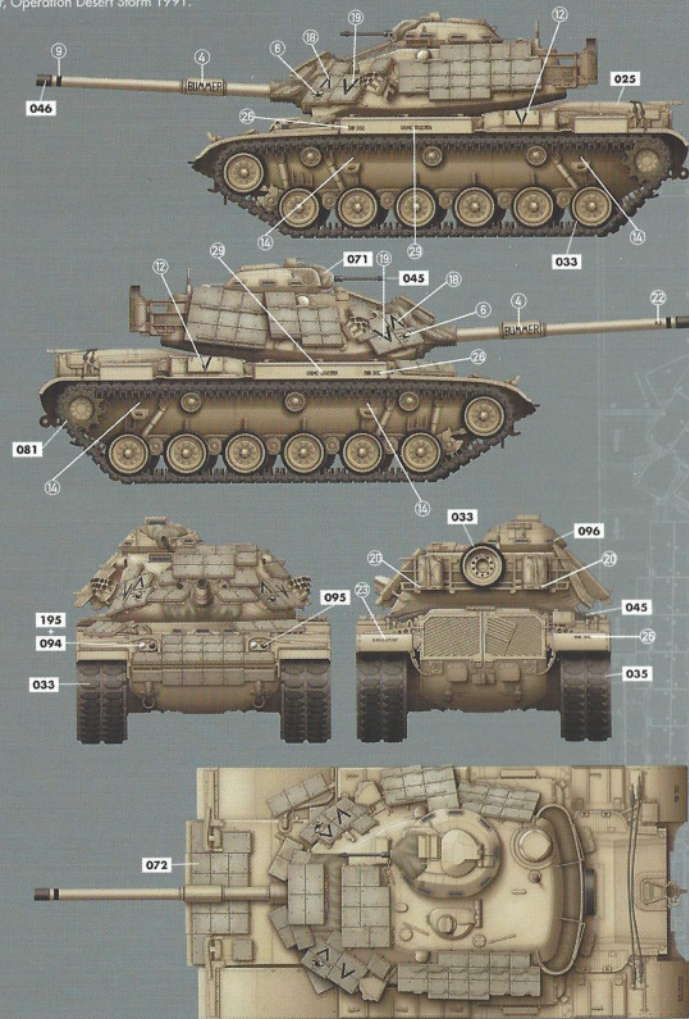

### WEATHERING STEPS WITH AMMO PRODUCTS

<b>1</b> GENERAL WASH A.MIG-1007 U.S Modern Vehicle Wash	<b>3</b> STREAKING A.MIG-1207 Streaking Grime for US Modern Vehicles	<b>5</b> DUST A.MIG-3018 Middle East Dust	<b>7</b> HEAVY MUD A.MIG-1701 Thick Soil
<b>2</b> FILTER A.MIG-1503 Ochre for Light Sand	<b>4</b> TRACK WASH A.MIG-1002 Tracks Wash	<b>6</b> SPLASHES A.MIG-1750 Dry Earth	<b>8</b> GREASE & OIL A.MIG-1408 Fresh Engine Oil

## Painting and Marking Guide

**TAKOM** Ref: 2113

1/35 U.S Marine main battle tank

C-51, HQ Platoon, Charlie Company, 3rd Tank Battalion USMC, Regimental Combat Team-7, Task Force Ripper, Operation Desert Storm 1991.

- |                                 |                                      |                                     |                         |
|---------------------------------|--------------------------------------|-------------------------------------|-------------------------|
| <b>A.MIG 033</b> Rubber & Tires | <b>A.MIG 035</b> Dark Tracks         | <b>A.MIG 045</b> Gun Metal          | <b>A.MIG 071</b> Khaki  |
| <b>A.MIG 094</b> Crystal Glass  | <b>A.MIG 095</b> Crystal Smoke       | <b>A.MIG 099</b> Crystal Black Blue | <b>A.MIG 195</b> Silver |
| <b>A.MIG 016</b> Gelbbraun      | <b>A.MIG 025</b> U.S Modern Vehicles | <b>A.MIG 046</b> Matt Black         |                         |

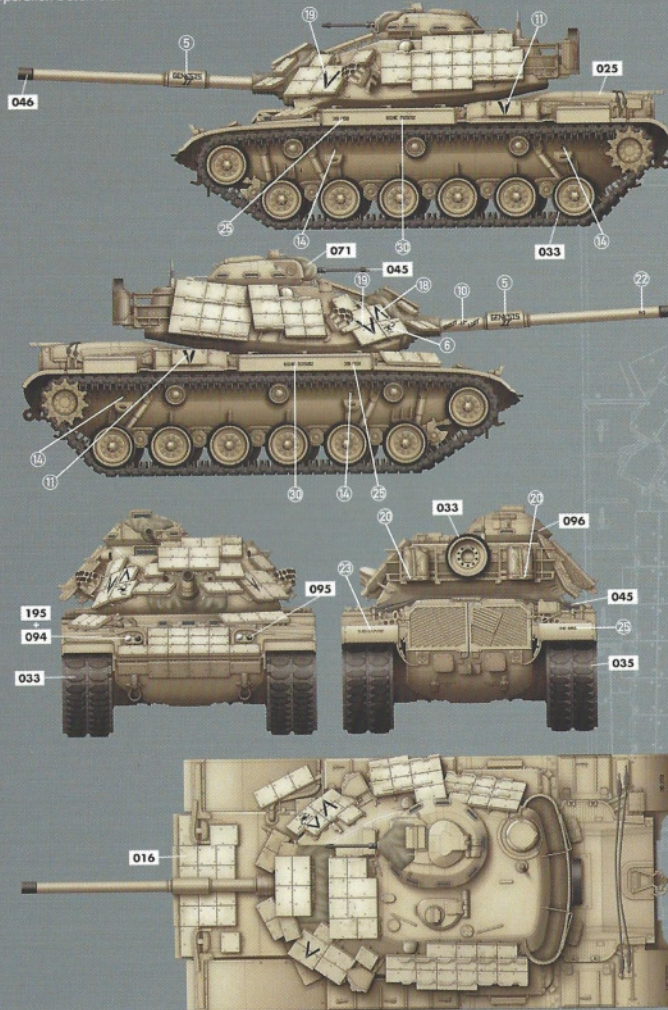

### WEATHERING STEPS WITH AMMO PRODUCTS

- |   |  |  |  |
|---|--|--|--|
| <b>1</b> GENERAL WASH<br>A.MIG-1007 U.S Modern Vehicle Wash | <b>3</b> STREAKING<br>A.MIG-1207 Streaking Gime for US Modern Vehicles | <b>5</b> DUST<br>A.MIG-3018 Middle East Dust | <b>7</b> HEAVY MUD<br>A.MIG-1701 Thick Soil          |
| <b>2</b> FILTER<br>A.MIG-1503 Ochre for Light Sand          | <b>4</b> TRACK WASH<br>A.MIG-1002 Tracks Wash                          | <b>6</b> SPLASHES<br>A.MIG-1750 Dry Earth    | <b>8</b> GREASE & OIL<br>A.MIG-1408 Fresh Engine Oil |

## Painting and Marking Guide

**TAKOM** Ref: 2113

1/35 U.S Marine main battle tank

C-12, 1st Platoon, Charlie Company, 3rd Tank Battalion USMC, Regimental Combat Team-7, Task Force Ripper, Operation Desert Storm 1991.

- |                                      |                                |                                     |                            |
|--------------------------------------|--------------------------------|-------------------------------------|----------------------------|
| <b>A.MIG 033</b> Rubber & Tires      | <b>A.MIG 035</b> Dark Tracks   | <b>A.MIG 045</b> Gun Metal          | <b>A.MIG 071</b> Khaki     |
| <b>A.MIG 094</b> Crystal Glass       | <b>A.MIG 095</b> Crystal Smoke | <b>A.MIG 099</b> Crystal Black Blue | <b>A.MIG 195</b> Silver    |
| <b>A.MIG 025</b> U.S Modern Vehicles | <b>A.MIG 046</b> Matt Black    | <b>A.MIG 073</b> Earth              | <b>A.MIG 055</b> Oil Ochre |

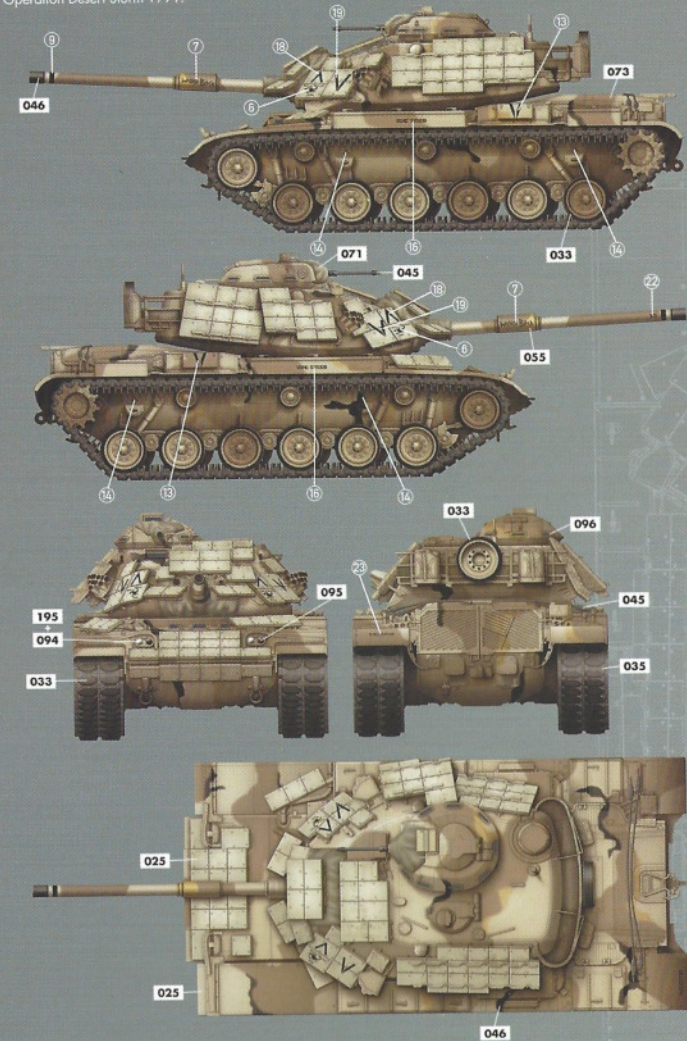

### WEATHERING STEPS WITH AMMO PRODUCTS

- |   |  |  |  |
|---|--|--|--|
| <b>1</b> GENERAL WASH<br>A.MIG-1001 Africa Korps Wash | <b>3</b> STREAKING<br>A.MIG-1207 Streaking Gime for US Modern Vehicles | <b>5</b> DUST<br>A.MIG-3018 Middle East Dust | <b>7</b> HEAVY MUD<br>A.MIG-1701 Thick Soil          |
| <b>2</b> FILTER<br>A.MIG-1510 TAN for 3 Tone Camo     | <b>4</b> TRACK WASH<br>A.MIG-1002 Tracks Wash                          | <b>6</b> SPLASHES<br>A.MIG-1750 Dry Earth    | <b>8</b> GREASE & OIL<br>A.MIG-1408 Fresh Engine Oil |



# APANTHER w/ Full Interior

MID-LATE Production

Sd.Kfz. 267  
Sd.Kfz. 171 **2in1**



DESIGNED BY  
TAKOM  
IN CHINA

Zimmerit Pattern  
created by  
**JASON**



*JASON 2018*

**1/35**  
No.2100

READY TO ASSEMBLE PRECISION MODEL KIT INTENDED FOR COLLECTORS OF AGE 14 YEARS AND ABOVE. MODEL MAY VARY FROM IMAGE ON BOX. CEMENT AND PAINT NOT INCLUDED.

# SOVIET HEAVY TANK

## SMK



THIS IS NOT A TOY  
DETAILED STATIC DISPLAY PLASTIC MODEL  
ALL HATCHES CAN BE BUILT IN OPEN OR CLOSED POSITION  
INDIVIDUAL TRACKS  
PE & CLEAR PARTS INCLUDED  
4 TYPES OF MARKING



*JASON 2018*

**1/35**  
No.2112

READY TO ASSEMBLE PRECISION MODEL KIT INTENDED FOR COLLECTORS OF AGE 14 YEARS AND ABOVE. MODEL MAY VARY FROM IMAGE ON BOX. CEMENT AND PAINT NOT INCLUDED.

# 勇虎 中華民國主力戰車

## R.O.C. ARMY MAIN BATTLE TANK



DESIGNED BY  
TAKOM  
IN CHINA

ALL HATCHES CAN BE BUILT IN OPEN OR CLOSED POSITION  
DETAILED STATIC DISPLAY PLASTIC MODEL  
PE & CLEAR PARTS INCLUDED  
FOUR TRACKS NOT INCLUDED  
ONE PIECE TRACKS  
THIS IS NOT A TOY



*JASON 2017*

**1/35**  
No.2090

### CM-11 (M-48H) Brave Tiger

READY TO ASSEMBLE PRECISION MODEL KIT INTENDED FOR COLLECTORS OF AGE 14 YEARS AND ABOVE. MODEL MAY VARY FROM IMAGE ON BOX. CEMENT AND PAINT NOT INCLUDED.

# 勇虎 附加裝甲型

## R.O.C. ARMY MAIN BATTLE TANK



DESIGNED BY  
TAKOM  
IN CHINA

ALL HATCHES CAN BE BUILT IN OPEN OR CLOSED POSITION  
DETAILED STATIC DISPLAY PLASTIC MODEL  
PE & CLEAR PARTS INCLUDED  
FOUR TRACKS NOT INCLUDED  
ONE PIECE TRACKS  
THIS IS NOT A TOY



*JASON 2017*

**1/35**  
No.2091

### CM-11 (M-48H) w/ERA Brave Tiger

READY TO ASSEMBLE PRECISION MODEL KIT INTENDED FOR COLLECTORS OF AGE 14 YEARS AND ABOVE. MODEL MAY VARY FROM IMAGE ON BOX. CEMENT AND PAINT NOT INCLUDED.



2018/2113

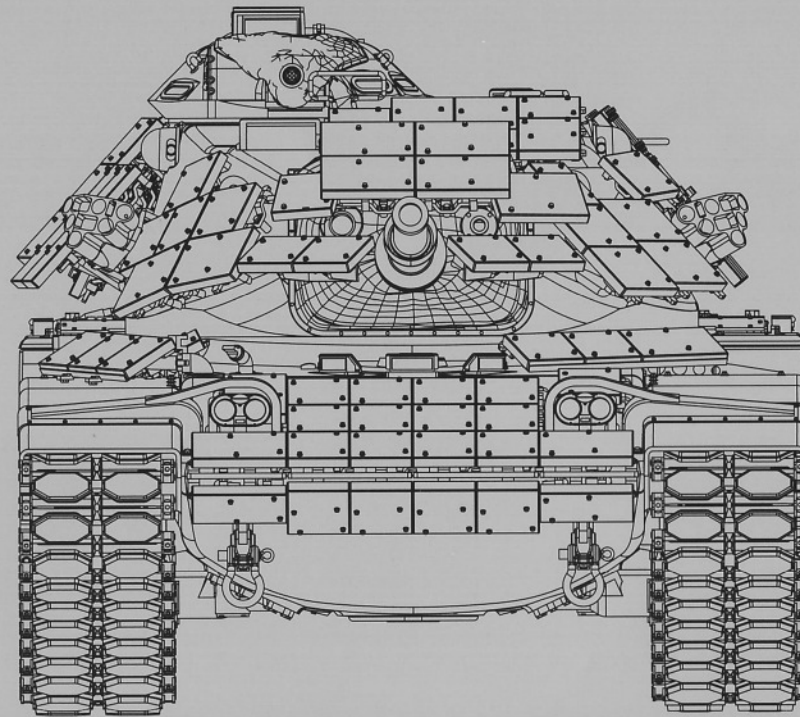

Takom would like to offer special thanks to Michael E. Mummey (MSgt USMC Ret) for his valuable assistance in researching this project. Mr. Mummey and his crew fought bravely in combat against Iraqi armored forces, proudly serving his country in C-12 Bummer during Operation Desert Storm in 1991, destroying multiple enemy tanks.  
Semper fidelis!



You can find TAKOM on Facebook.com