

DECALS FOR
DECALQUES POUR



F-4C/D "MIG KILLER"



CONTIENE UN MODELLO IN PLASTICA DA ASSEMBLARE - INSIDE ONE PLASTIC MODEL KIT - CONTIENT UNE MAQUETTE PLASTIQUE A MONTER - ENTHÄLT PLASTIK MODELLBAUSATZ - HET INHOUDT EEN PLASTIEK MODEL TE SAMENSTELLEN - INNEHALER PLASTBYGGSATZ - CONTIENE UN MODELO EN PLÁSTICA PARA SER MONTADO

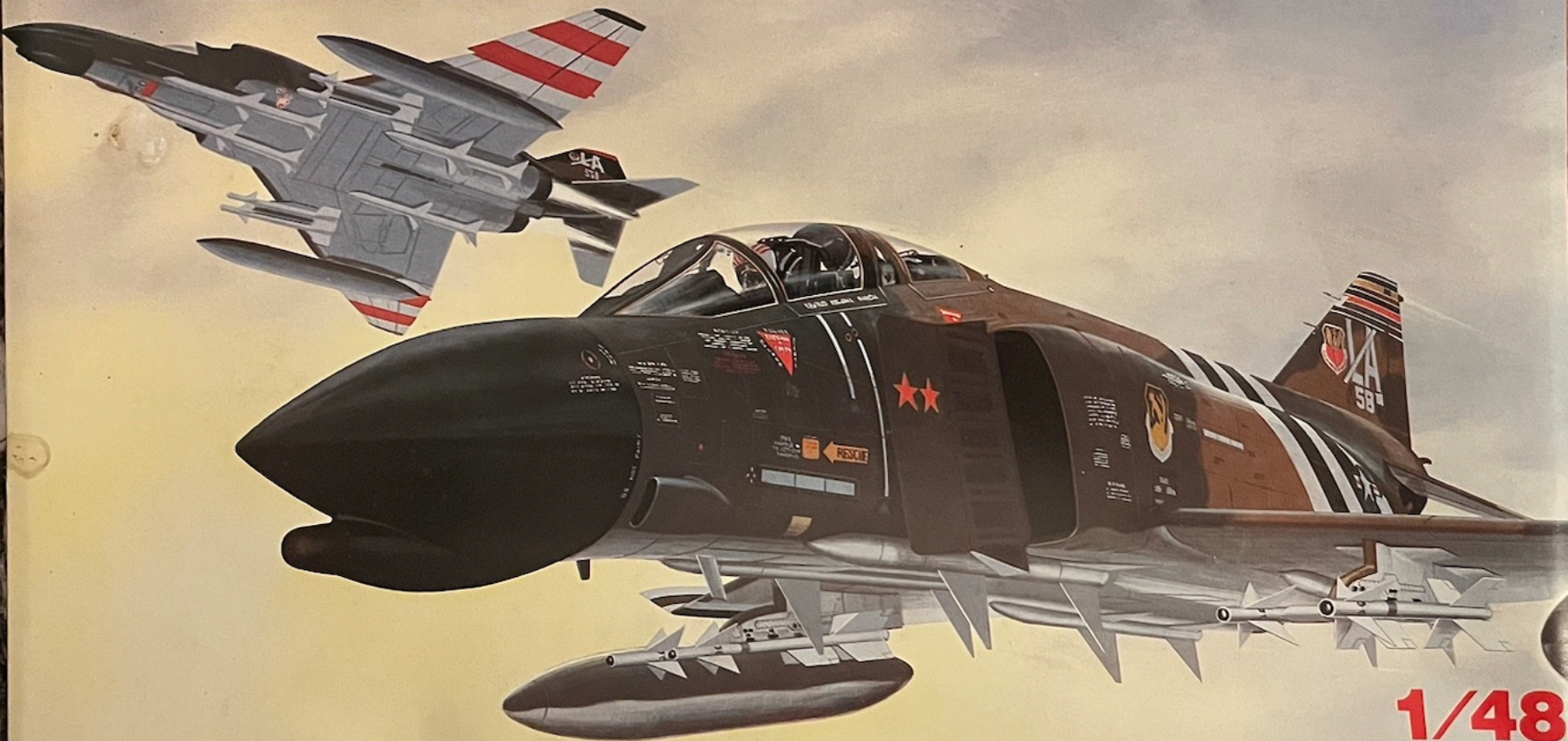

1/48

MADE IN ITALY

1/48th Scale - Echelle 1/48ème

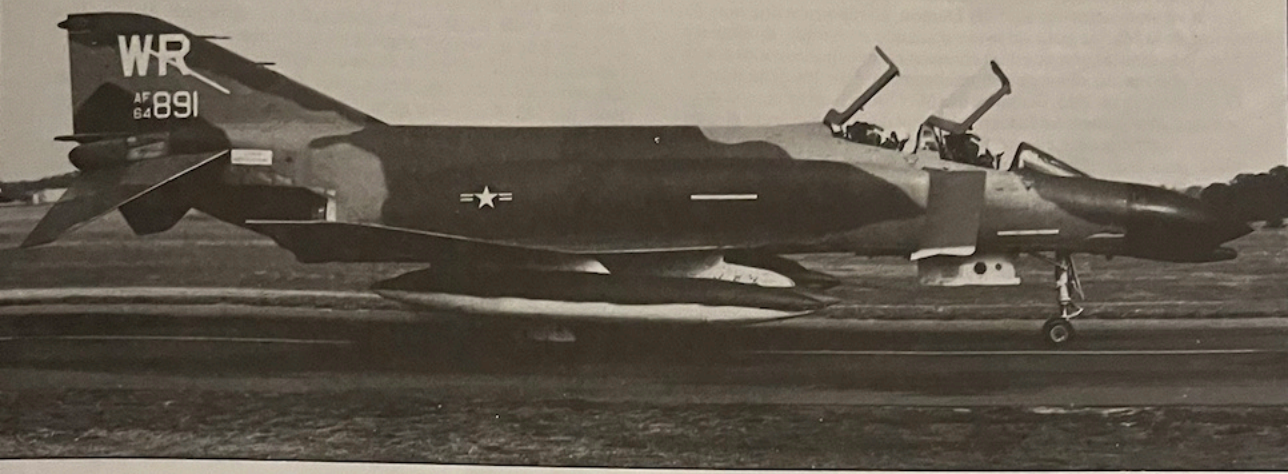

All'inizio del 1978, si è svolta una singolare cerimonia agli stabilimenti di St. Louis della Mc Donnell Douglas: veniva presentato alla stampa, verniciato in bianco e blu, il 5 millesimo Phantom (fantasma) costruito; per un moderno aereo militare, un traguardo veramente notevole. Il progetto Phantom II ebbe inizio nel 1953, e l'aereo doveva inizialmente essere la versione bireattore dell'F3H Demon, in risposta a una specifica della Marina per un aereo da attacco imbarcato, monoposto. Ma la sopravvenuta necessità di un caccia per le portaerei statunitensi, portò un notevole cambiamento nelle richieste dell'US Navy, che nel '55 chiese alla Mc Donnell un intercettore bisonico, con armamento missilistico e sofisticate apparecchiature elettroniche. Il progetto venne allora rimaneggiato, l'aereo diventò un biposto, per ospitare un addetto all'avioelettronica, ed ebbe notevoli migliorie aerodinamiche (tra le quali i caratteristici stabilizzatori montati con diedro negativo di 23°).

La marina statunitense ordinò 23 esemplari di preserie (F-4A). Il primo esemplare decollò il 27 maggio 1958, e in giugno l'F-4A sconfisse in competizione il suo diretto concorrente, l'F8U-3 Crusader III della LTV; la produzione in serie cominciò subito, e l'F-4 divenne il caccia standard dell'US Navy. Nel marzo 1962, con una decisione che quasi non aveva precedenti, veniva adottato anche dalla US Air Force, a riconferma delle eccezionali doti del velivolo. Esse si rivelarono in pieno nella guerra del Vietnam, dove l'aggressivo caccia della Mc Donnell Douglas fu l'aereo più versatile ed efficiente delle forze statunitensi.

Il Phantom, da purosangue qual era, si prestava naturalmente allo sviluppo di versioni specializzate. Le versioni C e D vennero realizzate per l'aviazione statunitense, ed ebbero un intensissimo impiego nel Sud Est asiatico.

L'F-4C, diretto sviluppo dell'F-4B della Marina, è stato il primo tipo di Phantom per l'US Air Force. Differiva dall'F-4B per le apparecchiature di navigazione più sofisticate, ruote più grandi, freni più resistenti e doppi comandi; ma soprattutto era realizzato per il ruolo di superiorità aerea e appoggio tattico, piuttosto che per intercettazione. La produzione fino al 1966 fu di 583 velivoli, di cui 36 vennero forniti all'aviazione spagnola.

L'F-4D era derivato dalla versione C, della quale costituiva un miglioramento, caratterizzato dall'installazione di un radar APQ-109, e dalla scomparsa, almeno nelle prime serie, del sensore dell'infrarosso sotto

il muso. All'USAF ne vennero consegnati 825, di cui 32 andarono poi all'Iran e 18 alla Corea del Sud.

An unusual ceremony took place at the beginning of 1978 in the Mc Donnell Douglas factories in St. Louis: the press was presented with a white and blue Phantom, the 5 thousandth of its kind, quite a record for a military plane.

The Phantom II project began in 1953 and the plane was initially meant to be a twin jet version of the F3H Demon, to comply with a specification from the Navy for a single seater embarked attack plane. But the subsequent need for a fighter for the U.S. aircraft carriers led to a considerable change in the US Navy demands and in fact in 1955 they asked Mc Donnell for a bisonic interceptor with missile armament and sophisticated electronic equipment.

The project was then rehandled, the plane became a twin seater, to make room for an avioelectronics expert and considerable aerodynamic improvements were made (including the characteristic stabilizers with 23° negative sweepback).

The U.S. Navy ordered 23 preserie planes (F-4A). The first one took off on May 27 1958 and in June the F-4A defeated her direct competitor the F8U-3 Crusader III by LTV; mass production began immediately and the F-4 became the standard U.S. Navy fighter. In March 1962, with a decision almost without precedents, it was adopted also by the US Air Force, again confirming the exceptional qualities of the plane. These qualities were fully revealed during the Vietnam war where the aggressive Mc Donnell Douglas fighter was the most versatile and efficient plane used by the U.S. forces.

The Phantom, being the thoroughbred it was, was ideal to develop special versions. The C and D versions were made for the U.S. Air Force and were widely used in South East Asia.

The F-4C, directly developed from the Navy's F-4B, was the first type of Phantom for the US Air Force. It differed from the F-4B in that the navigating equipment was more sophisticated, the wheels were bigger, the brakes more resistant and it had double controls; but it was above all made for the role of air superiority and tactical support, rather than for interception. Production up to 1966 was of 583 planes, 36 of which were supplied to the Spanish air force.

The F-4D derived from the C version, of which it was an improve-

GRIGIO SCURO
DARK GRAY
GRIS FONCE
DUNKELGRAU
MÖRKGRÄ
GRIS OSCURO
67 TANK GREY

69

57

GRIGIO CHIARO
LIGHT GRAY
GRIS CLAIR
HELLGRAU
LJUSGRÄ
GRIS CLARO
64 LIGHT GREY

DECAL 41

VERDE CHIARO
LIGHT GREEN
VERT CLAIR
HELLGRÜN
LJUSGRÖN
VERDE CLARO
HUB GREEN

NERO
BLACK
NOIR
SCHWARZ
SVART
NEGRO
85 COAL BLACK

28

VERDE SCURO
DARK GREEN
VERT FONCE
DUNKELGRÜN
MÖRKGRÖN
VERDE OSCURO
30 OLIVE GREEN

70

GRIGIO SCURO
DARK GRAY
GRIS FONCE
DUNKELGRAU
MÖRKGRÄ
GRIS OSCURO
67 TANK GREY

DECAL 39

32

35

67

GRIGIO CHIARO
LIGHT GRAY
GRIS CLAIR
HELLGRAU
LJUSGRÄ
GRIS CLARO
64 LIGHT GREY

61

GIALLO
YELLOW
JAUNE
GELB
GUL
AMARILLO
69 LEMON YELLOW



NERO
BLACK
NOIR
SCHWARZ
SVART
NEGRO
85 COAL BLACK

DECAL 36

33

NERO
BLACK
NOIR
SCHWARZ
SVART
NEGRO
85 COAL BLACK

36

DECAL 38

DECAL 37

DECAL 40

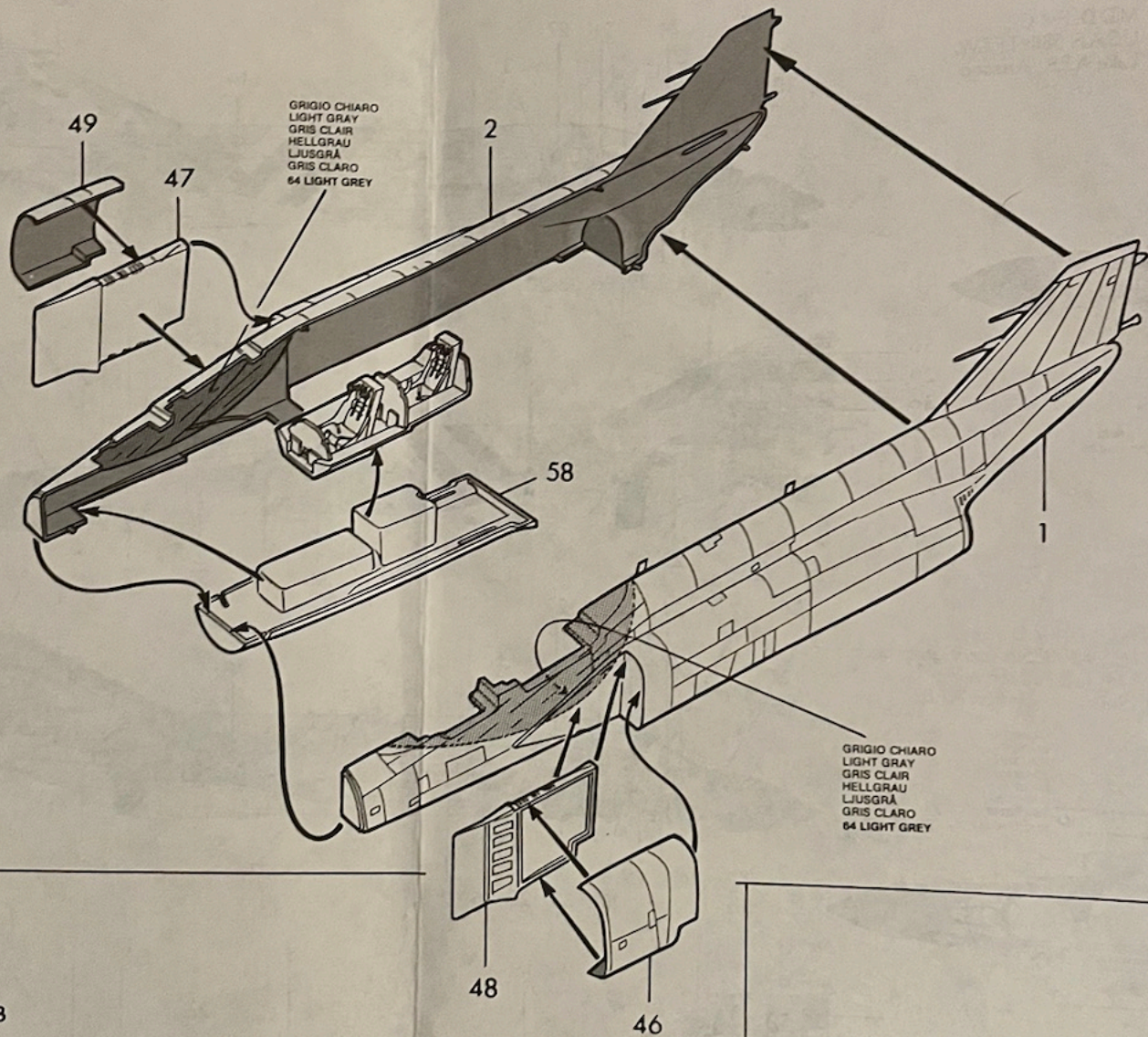

VERDE
GREEN
VERT
GRÜN
GRÖN
VERDE
HU17 GREEN

44

43

22

ROSSO
RED
ROUGE
ROT
RÖD
ROJO
60 SCARLET

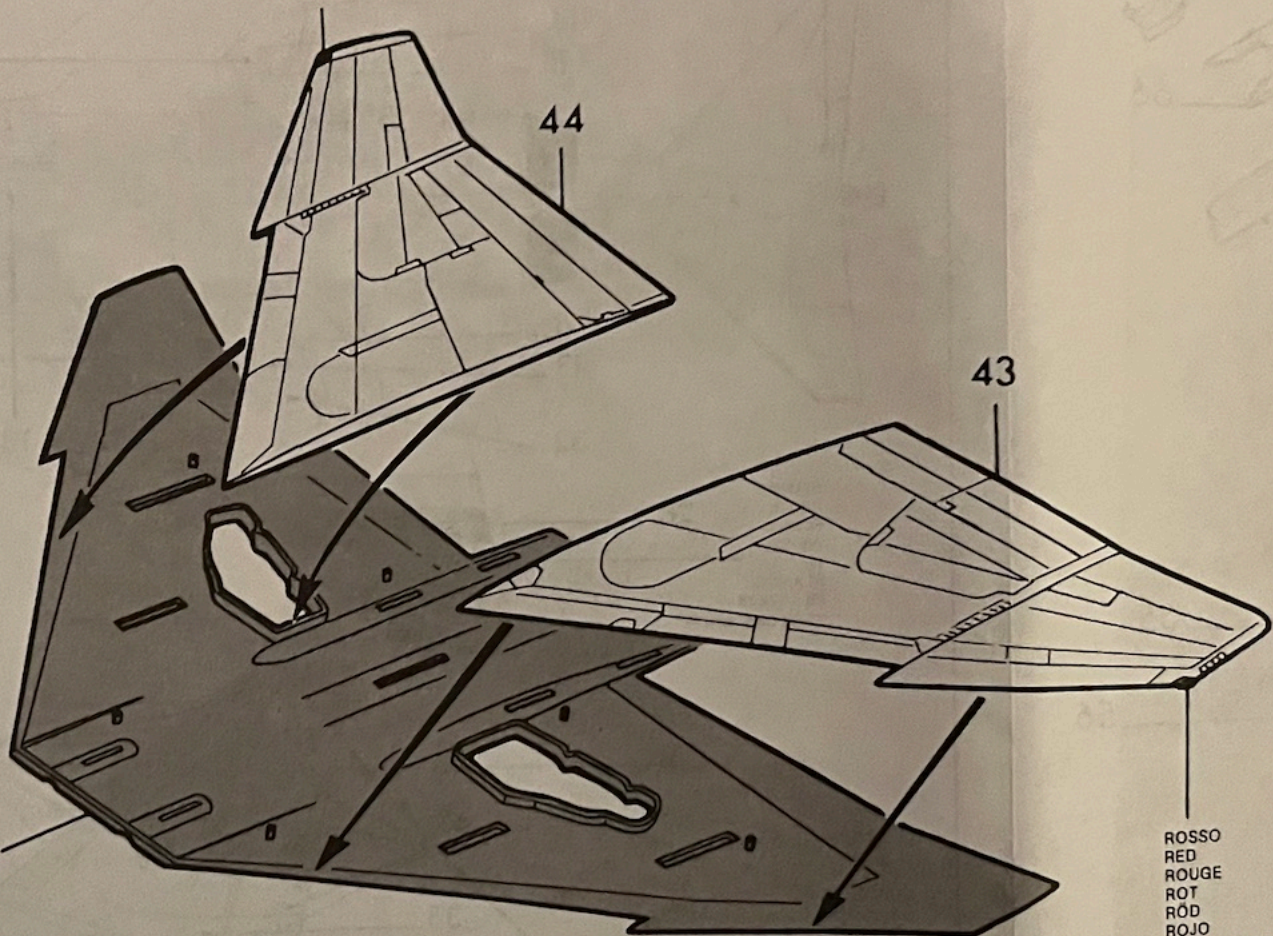

TRASPARENTE
CLEAR
TRASPARENT
KLARSICHTEILE
TRANSPARENT
TRASPARENTE

GRIGIO CHIARO
LIGHT GRAY
GRIS CLAIR
HELLGRAU
LJUSGRÅ
GRIS CLARO
64 LIGHT GREY

39

41

23

25

25

42

45

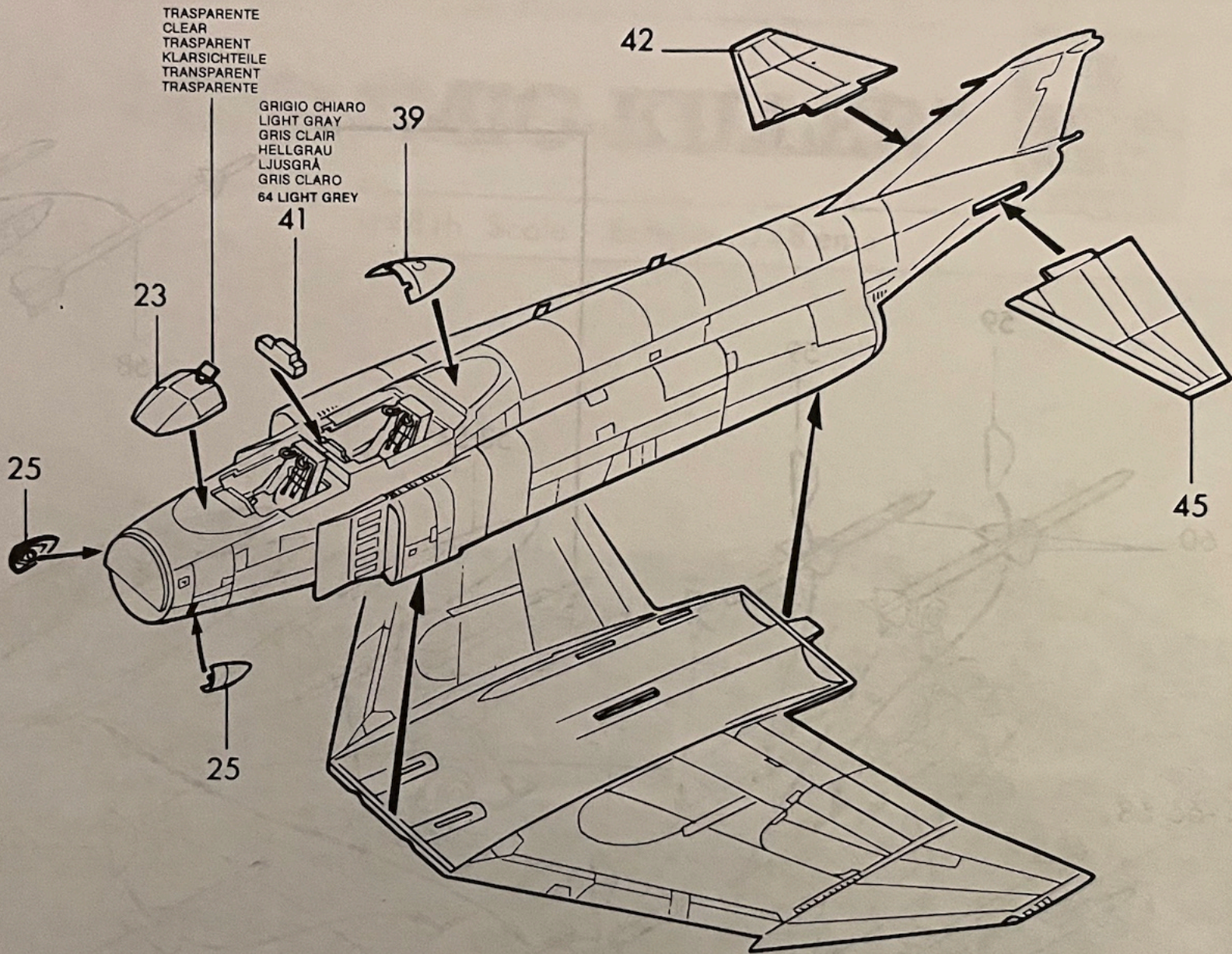

84 LIGHT GREY

DECAL 40

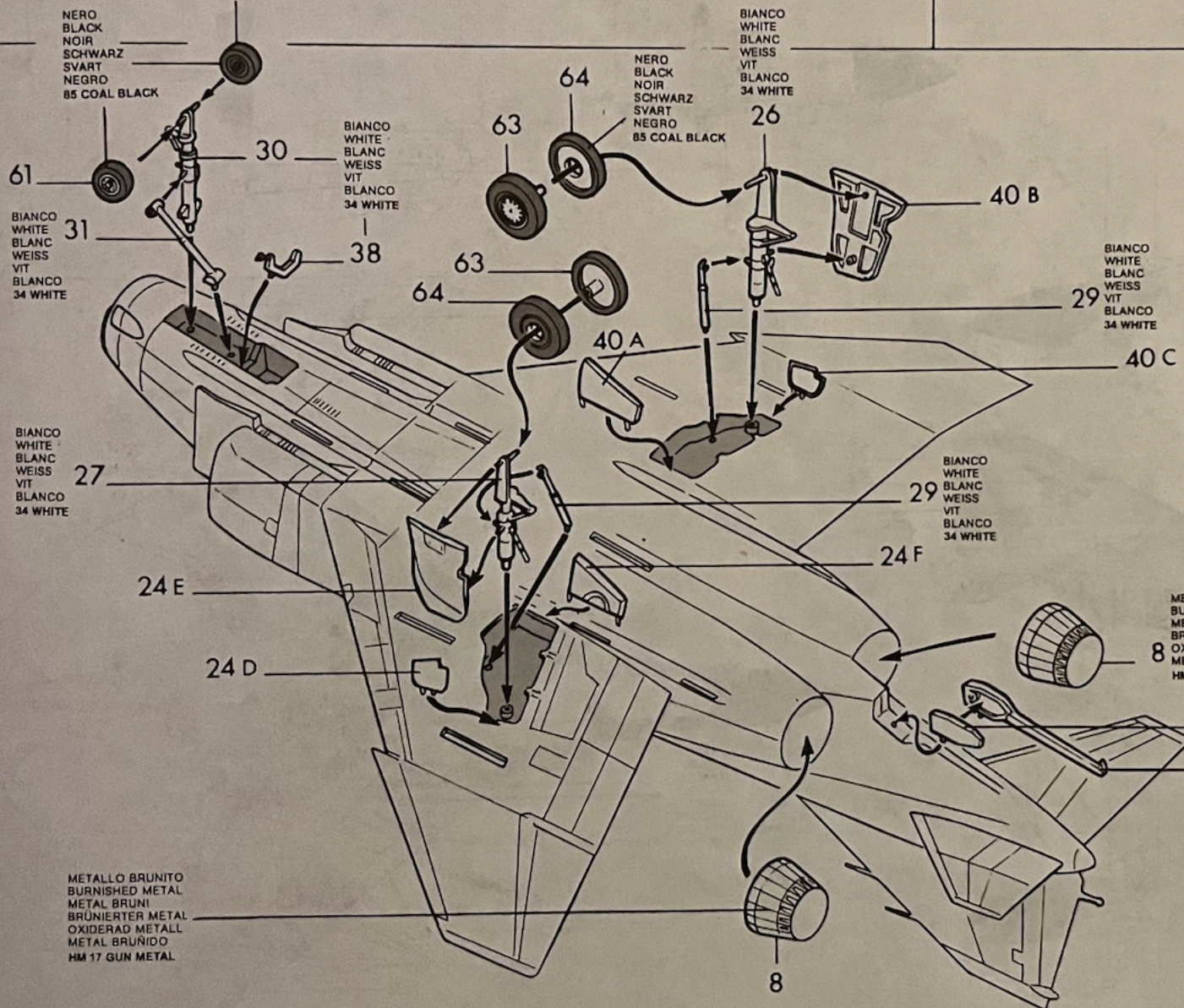

NERO
BLACK
NOIR
SCHWARZ
SVART
NEGRO
85 COAL BLACK

BIANCO
WHITE
BLANC
WEISS
VIT
BLANCO
34 WHITE

NERO
BLACK
NOIR
SCHWARZ
SVART
NEGRO
85 COAL BLACK

BIANCO
WHITE
BLANC
WEISS
VIT
BLANCO
34 WHITE

BIANCO
WHITE
BLANC
WEISS
VIT
BLANCO
34 WHITE

BIANCO
WHITE
BLANC
WEISS
VIT
BLANCO
34 WHITE

BIANCO
WHITE
BLANC
WEISS
VIT
BLANCO
34 WHITE

BIANCO
WHITE
BLANC
WEISS
VIT
BLANCO
34 WHITE

METALLO BRUNITO
BURNISHED METAL
METAL BRUNI
BRÜNIERTER METAL
OXIDERAD METALL
METAL BRUÑIDO
HM 17 GUN METAL

METALLO BRUNITO
BURNISHED METAL
METAL BRUNI
BRÜNIERTER METAL
OXIDERAD METALL
METAL BRUÑIDO
HM 17 GUN METAL

METALLO BRUNITO
BURNISHED METAL
METAL BRUNI
BRÜNIERTER METAL
OXIDERAD METALL
METAL BRUÑIDO
HM 17 GUN METAL

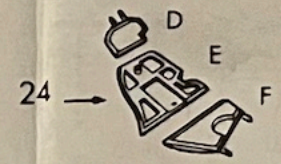
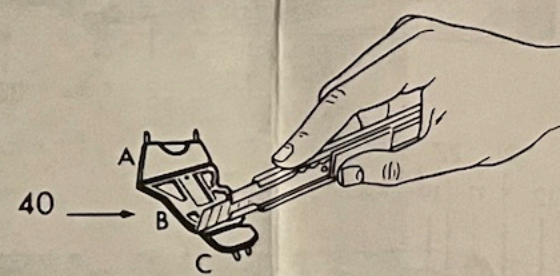
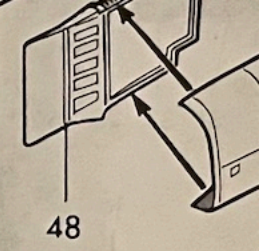

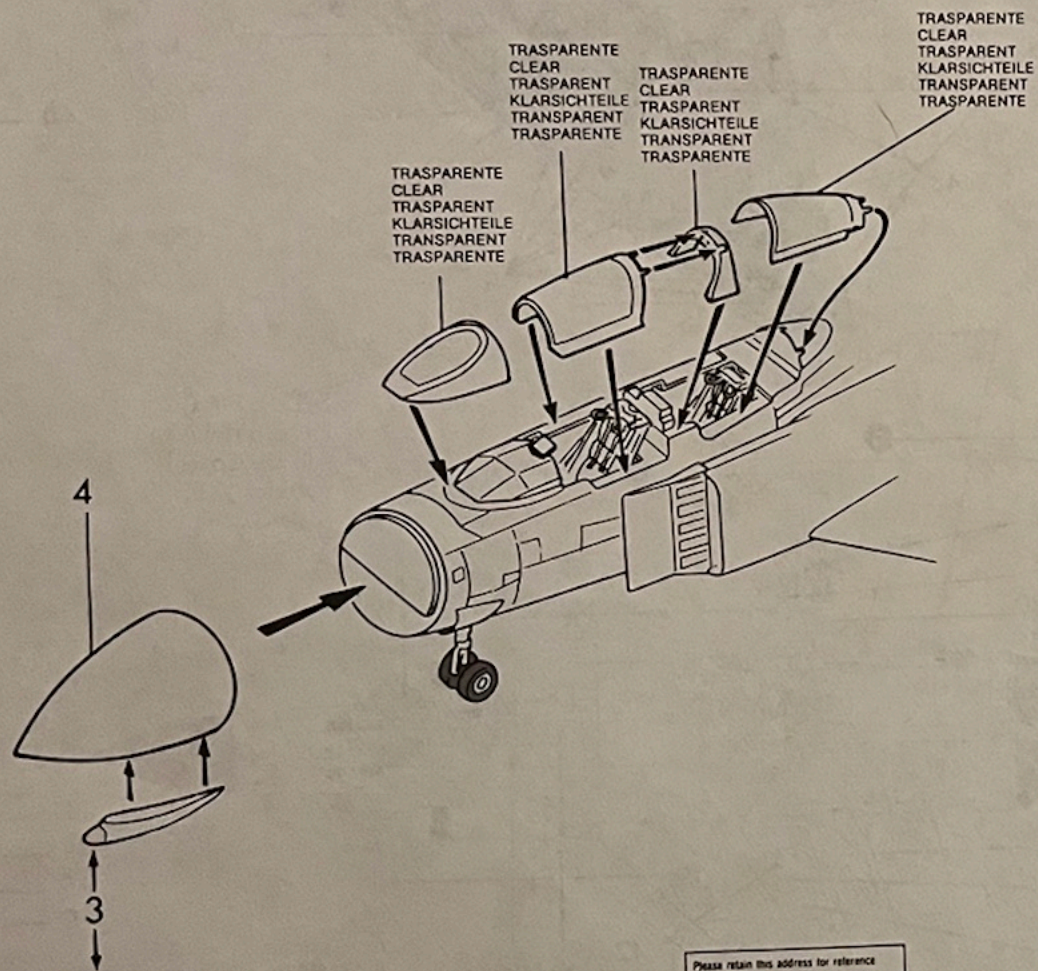

alternative: C version only.

Please retain this address for reference
 Veuillez conserver cette adresse pour
 références ultérieures.
 Pregasi conservare questo indirizzo per
 futuro riferimento.
 Diese Adresse bitte aufbewahren
 Dit adres a u. b. bewaren zodat het later
 beschikbaar is.
 Var god spara denna adress för referens
 La rogamos que guarde esta dirección como
 referencia.
 Favor guardar esta endereço para referência
 Παρακαλούμε κρατήστε αυτή τη

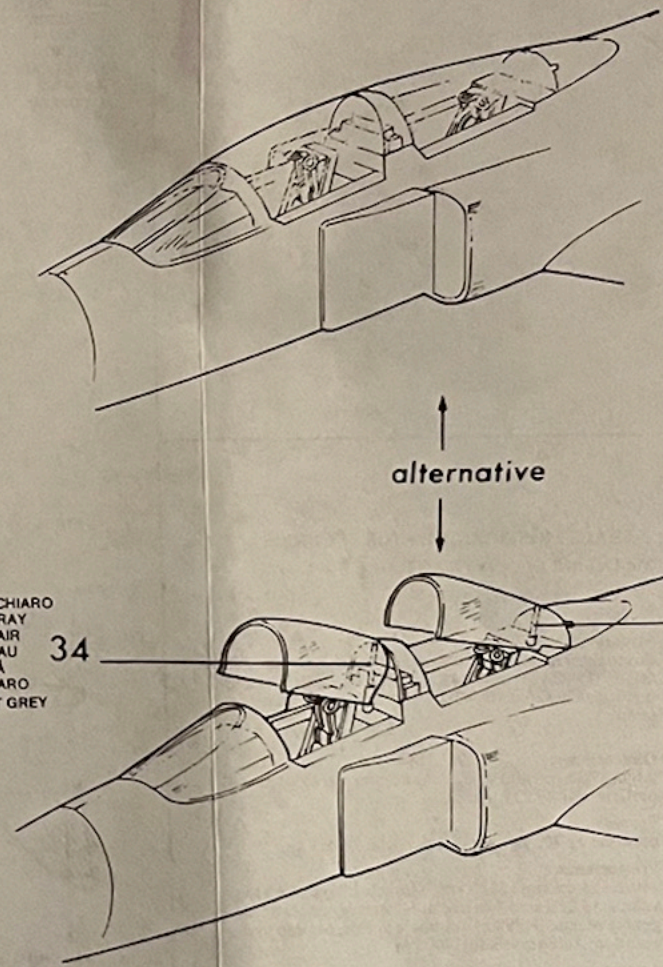

GRIGIO CHIARO
 LIGHT GRAY
 GRIS CLAIR
 HELLGRAU
 LJUSGRÅ
 GRIS CLARO
 64 LIGHT GREY

GRIGIO CHIARO
 LIGHT GRAY
 GRIS CLAIR
 HELLGRAU
 LJUSGRÅ
 GRIS CLARO
 64 LIGHT GREY

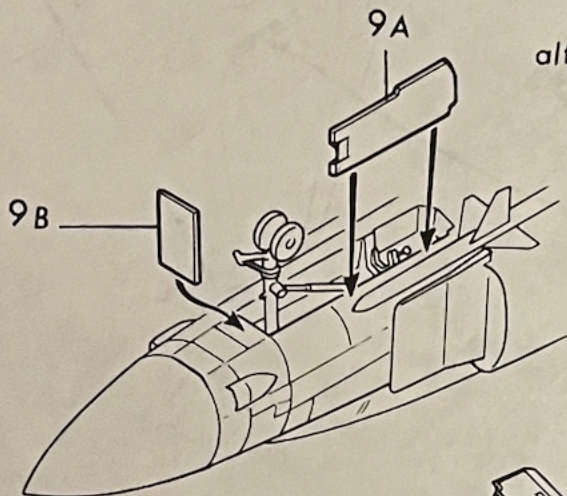

alternative: D version only.

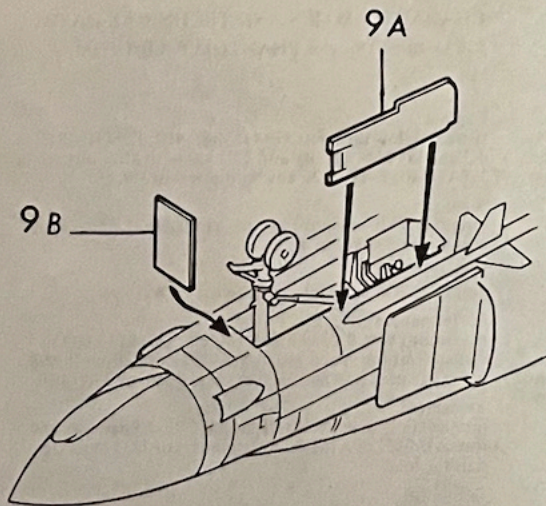
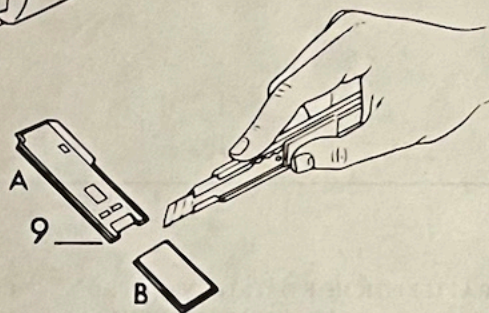

alternative: C version only.

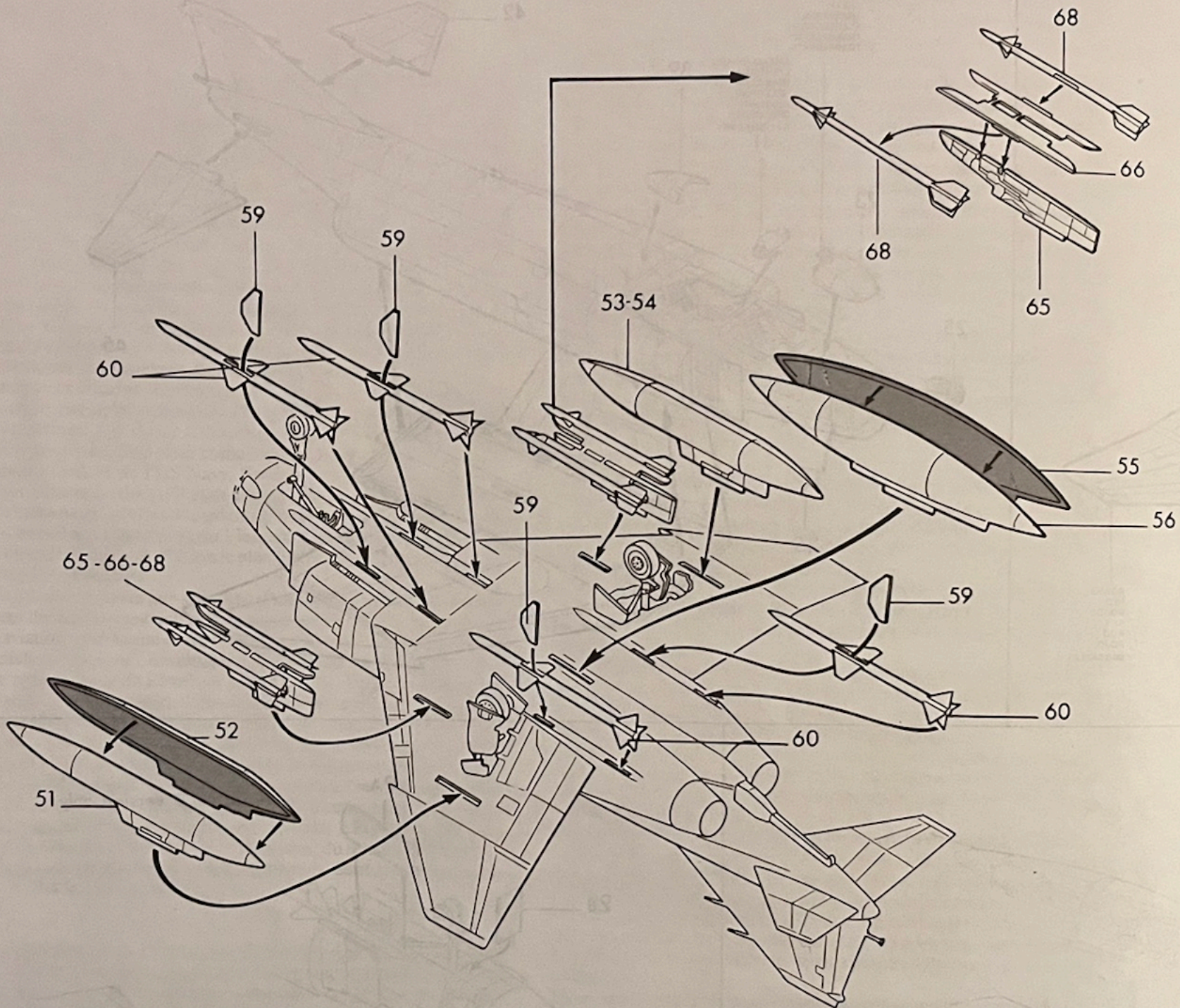

METALLO BRUNITO
BURNISHED METAL
METAL BRUNI
BRÜNIERTER METAL
OXIDERAD METALL
METAL BRILINDO
FS - 17178
56 ALUMINIUM

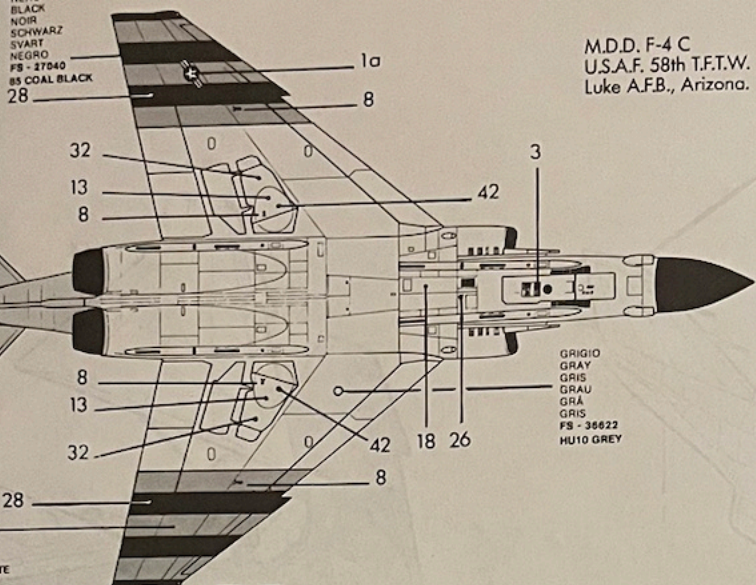

M.D.D. F-4 C
U.S.A.F. 58th T.F.T.W.
Luke A.F.B., Arizona.

GRIGIO
GRAY
GRIS
GRAU
GRÁ
GRIS
FS - 36622
HU10 GREY

BIANCO
WHITE
BLANC
WEISS
VIT
BLANCO
FS - 17875
22 GLOSS WHITE

5a
2a
3a

VERDE SCURO
DARK GREEN
VERT FONCE
DUNKELGRÜN
MÖRKGRÖN
VERDE OSCURO
FS - 34079
HUT GREEN

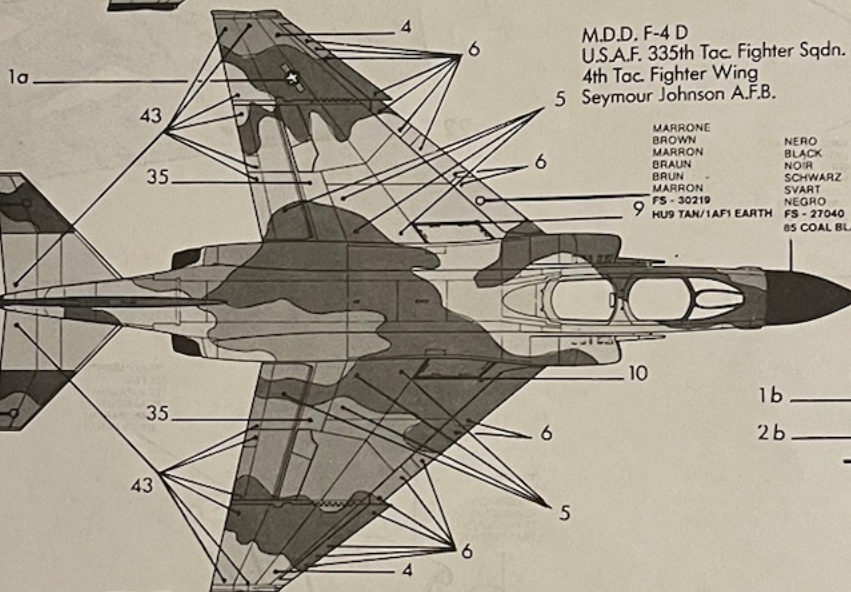

M.D.D. F-4 D
U.S.A.F. 335th Tac. Fighter Sqdn.
4th Tac. Fighter Wing
Seymour Johnson A.F.B.

MARRONE
BROWN
MARRON
BRAUN
BRÜN
MARRON
FS - 30219
HÜ9 TAN/1A/F1 EARTH

NERO
BLACK
NOIR
SCHWARZ
SVART
NEGRO
FS - 27040
85 COAL BL

VERDE CHIARO
LIGHT GREEN
VERT CLAIR
HELLGRÜN
LJUSGRÖN
VERDE CLARO
FS - 34102
HUB GREEN

1b
2b

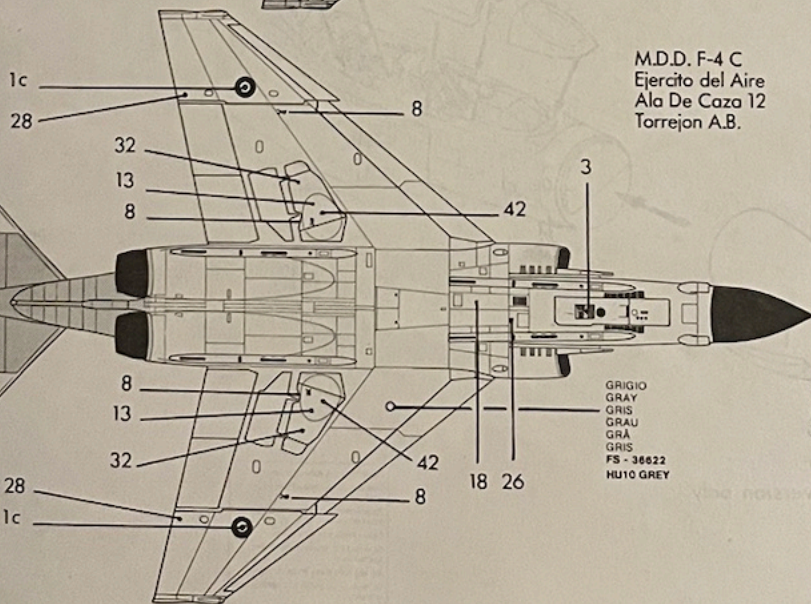

M.D.D. F-4 C
Ejército del Aire
Ala De Caza 12
Torrejon A.B.

GRIGIO
GRAY
GRIS
GRAU
GRÁ
GRIS
FS - 36622
HU10 GREY

METALLO BRUNITO
BURNISHED METAL
METAL BRUNI
BRÜNIERTER METAL
OXIDERAD METALL
METAL BRILINDO
FS - 17178
56 ALUMINIUM

2c
5c
3c

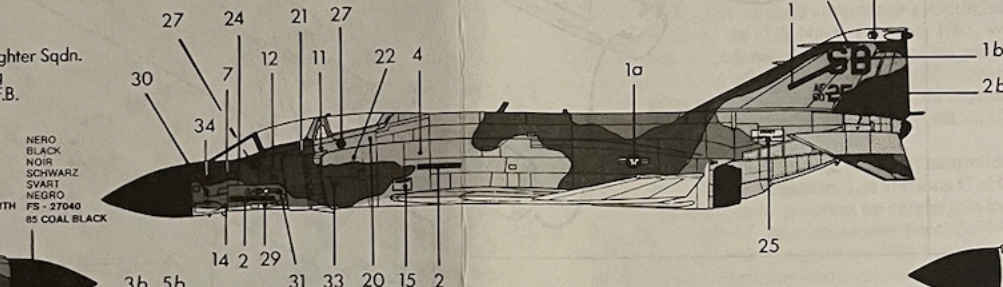
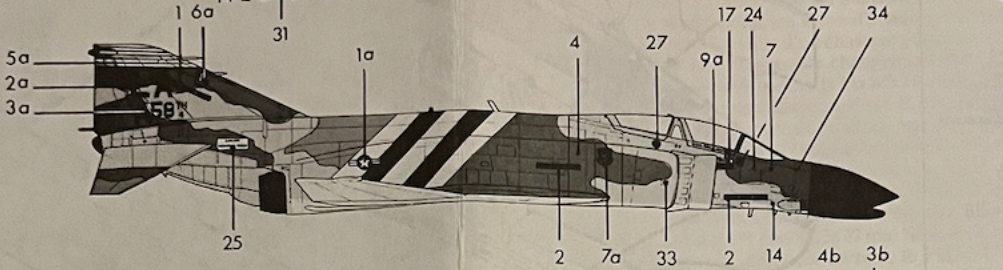
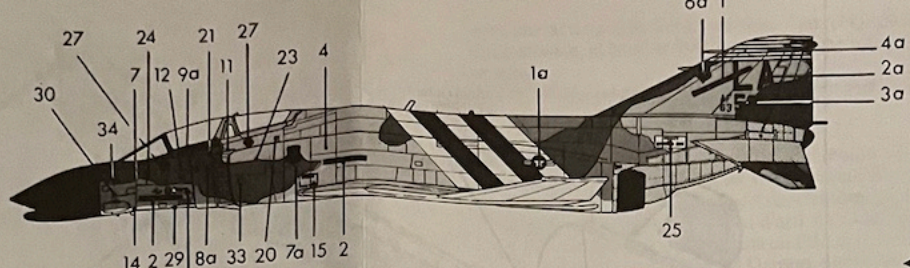

ighter Sqdn.
g
.F.B.

NERO
BLACK
NOIR
SCHWARZ
SVART
NEGRO
FS - 27040
85 COAL BLACK

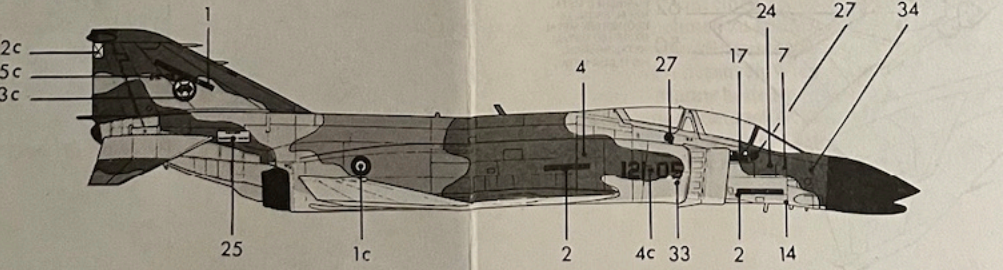
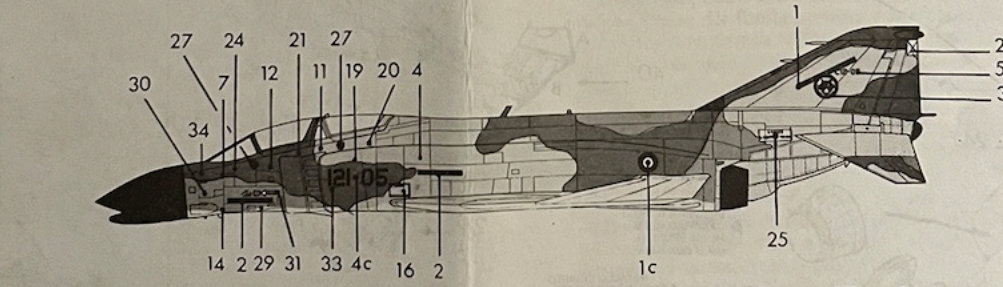
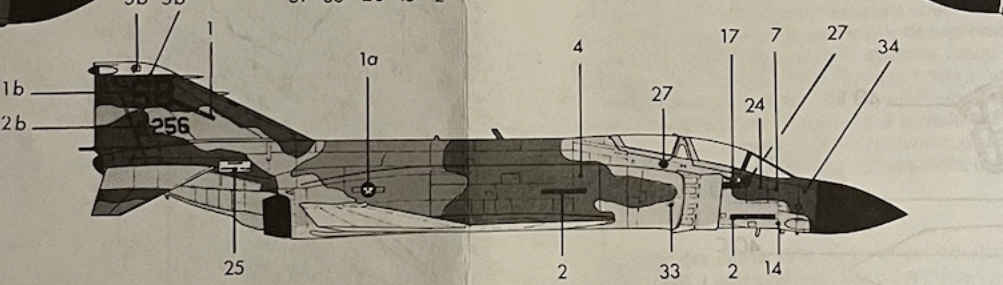

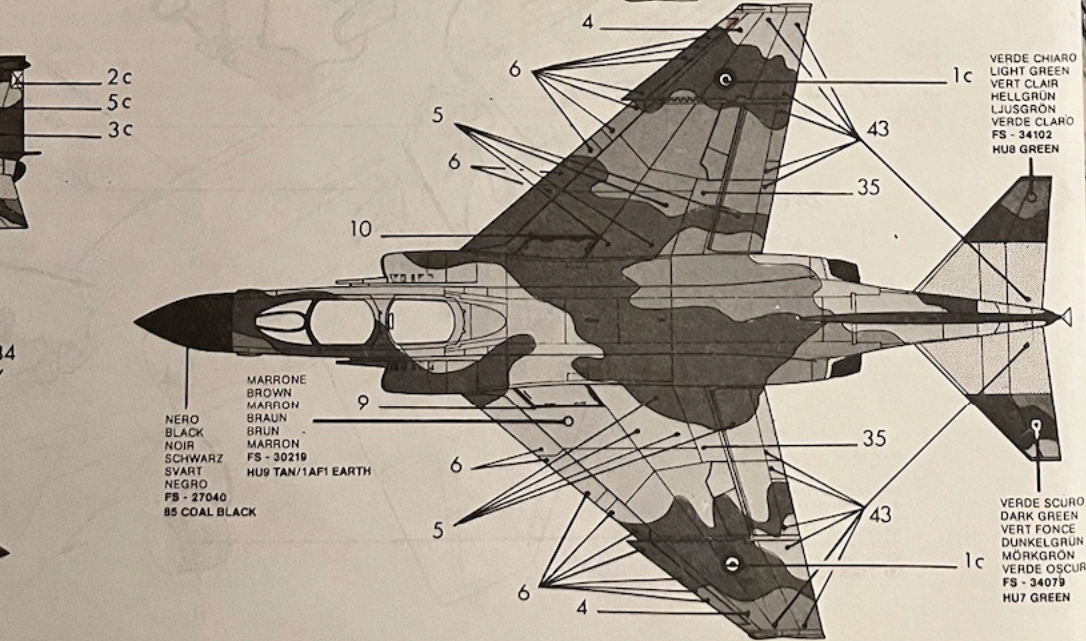
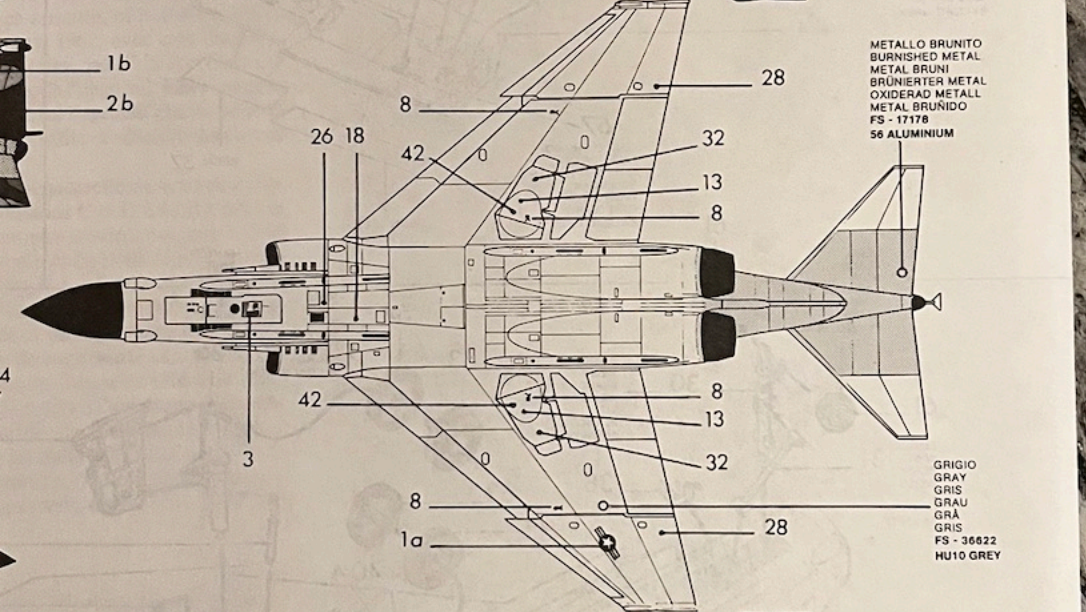
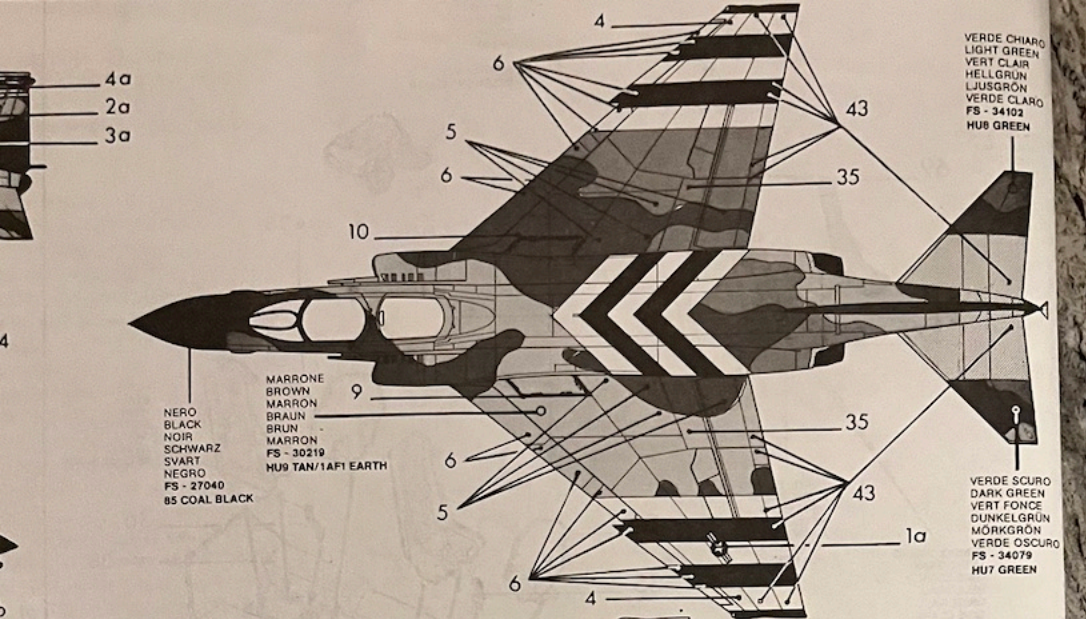

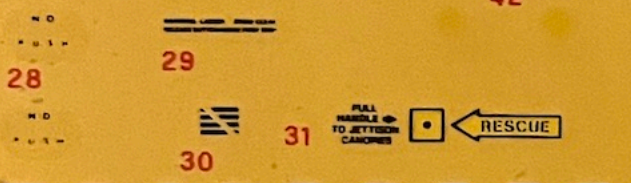
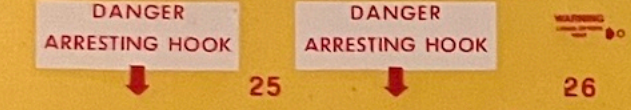
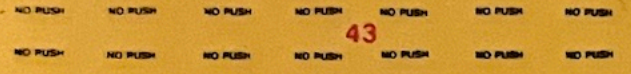
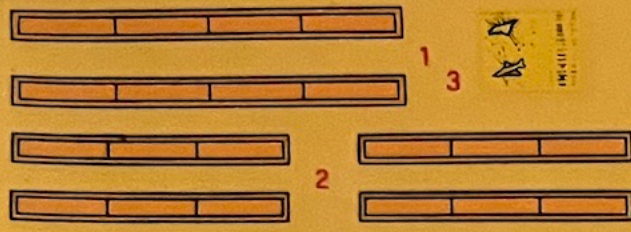

NO STEP
NO STEP
NO STEP
NO STEP
NO STEP
NO STEP
NO STEP
NO STEP

NO STEP
NO STEP
NO STEP
NO STEP
NO STEP
NO STEP
NO STEP
NO STEP



WARNING
THIS AIRCRAFT CONTAINS A CANOPY RESCUE CONTAINER AN EXPLOSIVE CHARGE

WARNING
THIS AIRCRAFT CONTAINS A CANOPY RESCUE CONTAINER AN EXPLOSIVE CHARGE

WARNING
THIS AIRCRAFT CONTAINS A CANOPY RESCUE CONTAINER AN EXPLOSIVE CHARGE

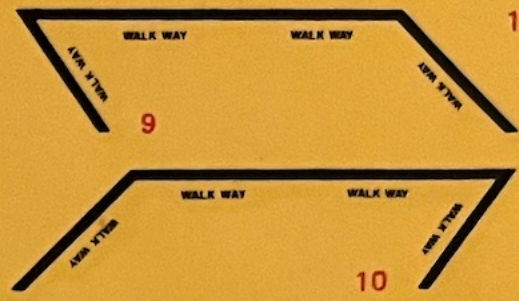

11 CANOPY AFT
OPEN CLOSE

12 CANOPY FWD
OPEN CLOSE

WARNING
APPROACHING WINGS, AND BRACE IMMEDIATELY ON AFT DIRECTION ONLY BRING SUPPLEMENT CAUTION

WARNING
APPROACHING WINGS, AND BRACE IMMEDIATELY ON AFT DIRECTION ONLY BRING SUPPLEMENT CAUTION



22 U.S. AIR FORCE MC F-4D
AF SERIAL NO. 60-256
BLOCK NO. 34
SERVICE THIS AIRCRAFT
NOTE GRADE JP-4 FUEL
REFERENCE TO 4301-1-14

23 U.S. AIR FORCE MC F-4C/D
AF SERIAL NO. 60-254
BLOCK NO. 34
SERVICE THIS AIRCRAFT
NOTE GRADE JP-4 FUEL
REFERENCE TO 4301-1-14



CAUTION
APPROACHING WINGS, AND BRACE IMMEDIATELY ON AFT DIRECTION ONLY BRING SUPPLEMENT CAUTION

24 CAUTION
APPROACHING WINGS, AND BRACE IMMEDIATELY ON AFT DIRECTION ONLY BRING SUPPLEMENT CAUTION



2 LALA



AF 63 58 TH 4 3 AF 63 58 TH 4

A 9 B/GEN FRED A. HAEFFNER
B/GEN FRED A. HAEFFNER



1 SB AF 60 256 2 3
SB AF 60 256 B 4 5



C 121-05 121-05 4

CI2-09 5
CI2-09

