



FLYING EYE



Fw 189

Please read this first!

Before you begin building, look over the instructions carefully. Following the procedure given, test-fit parts together without cementing. This way you will be more familiar with the parts when it becomes time to use the cement.

For removing small parts from the "runners" it's best to use a modeler's knife. Do not attempt to twist them off.

The highest quality styrene plastic goes into the making of each MPC model. Only cement made for styrene should be used. Before joining parts, trim off excess plastic or "flash". Be careful not to get cement on exposed areas. To join parts, use cement sparingly. Apply cement to very small parts with a toothpick. You should have no trouble assembling your kit if the instructions are followed properly.

The FW 189A reconnaissance and army co-operation aircraft was known as 'The Flying Eye' and was one of the most important and most successful Luftwaffe types, especially on the Eastern front. In service the FW189A completely replaced all earlier tactical reconnaissance and co-operation aircraft and was also used for light bombing missions. It proved extremely reliable and its ability to absorb punishment and defend itself made it extremely popular with its crews. When FE 189 construction ended in 1944 over 800 had been built, most of which went into action on the Russian front. Powered by two Argus 410 engines of 465 h.p. each, the FW 189A-1 had a maximum speed of 217 m.p.h. and a range of 416 miles. Armament consisted of four 7.9 mm machine guns and up to 440 lbs. of bombs. Wing span was 60 ft. 4½ ins. and length 39 ft. 5½ ins.

Assembly Guide

	Step numbers	
Cement	6	
Do not cement	5	Part numbers as engraved on runner or parts

1

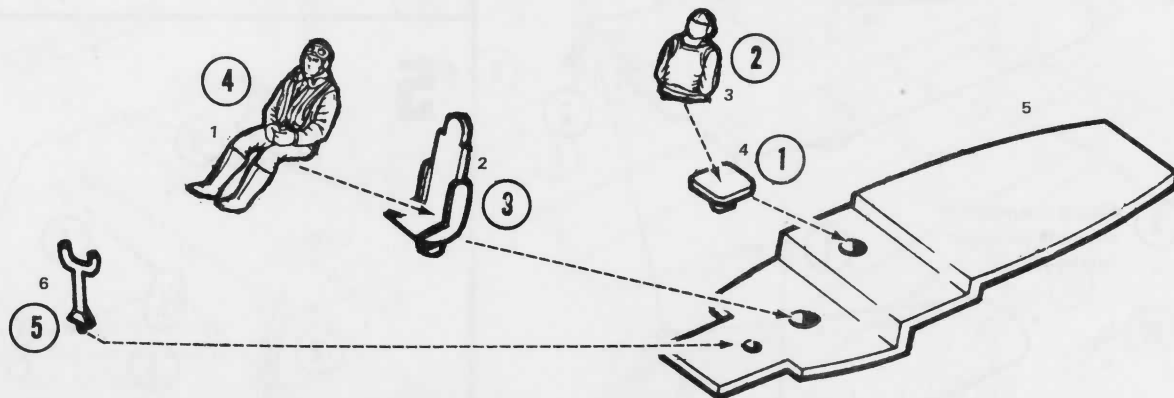

2

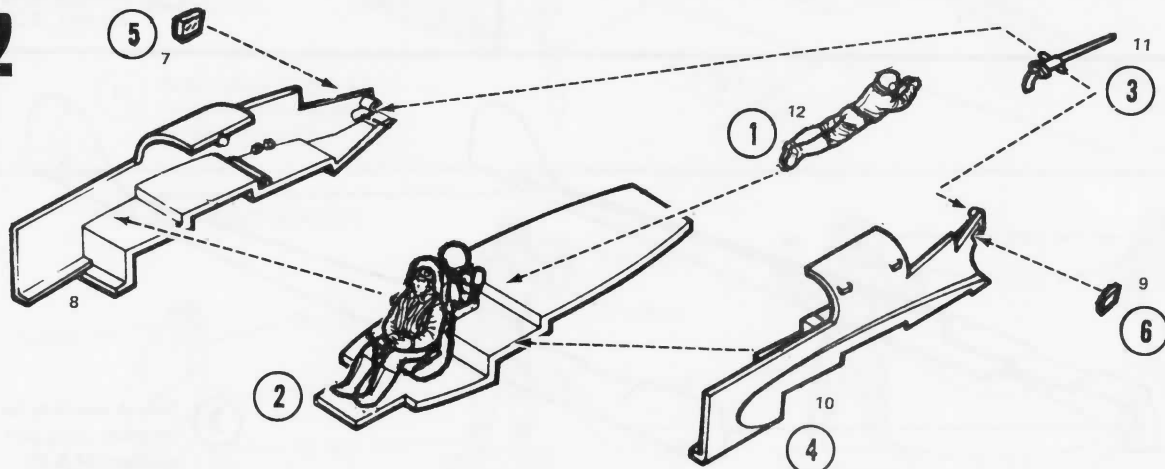

3

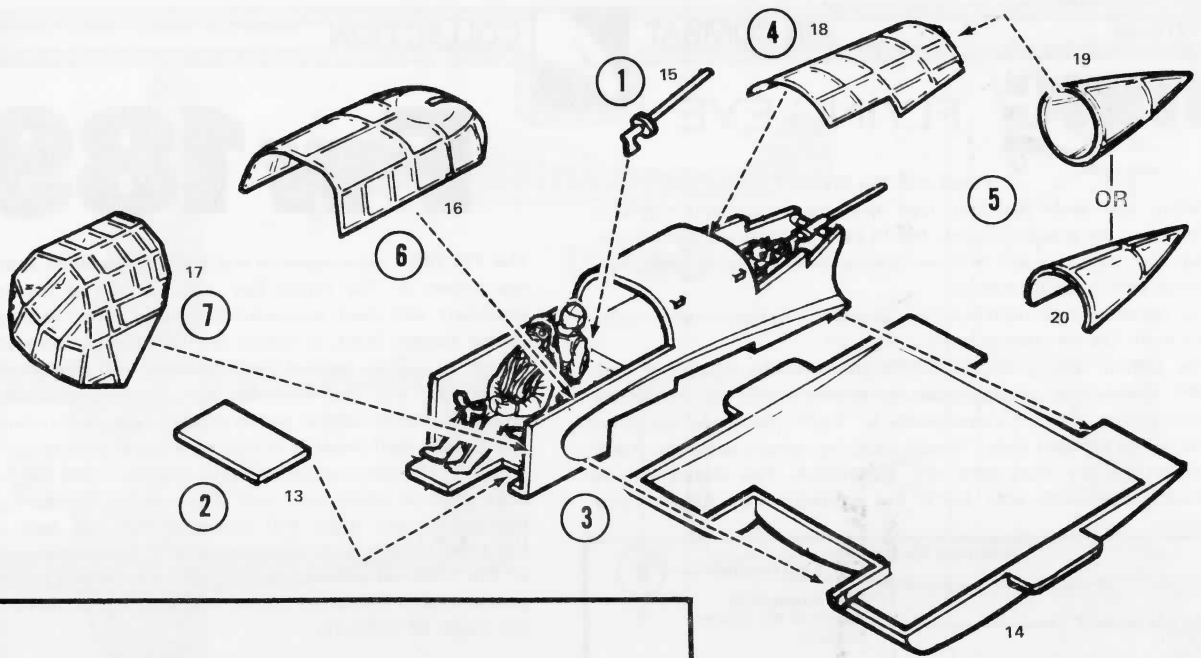

4

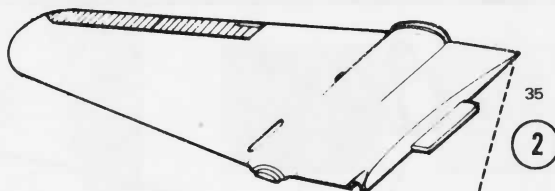

3 Repeat assembly for
otherside using part
numbers 21-23.

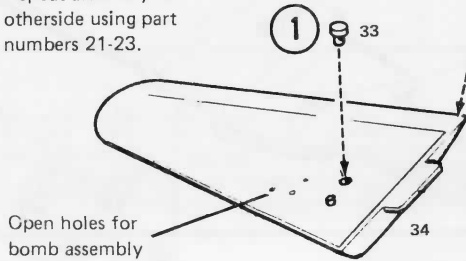

Open holes for
bomb assembly

5

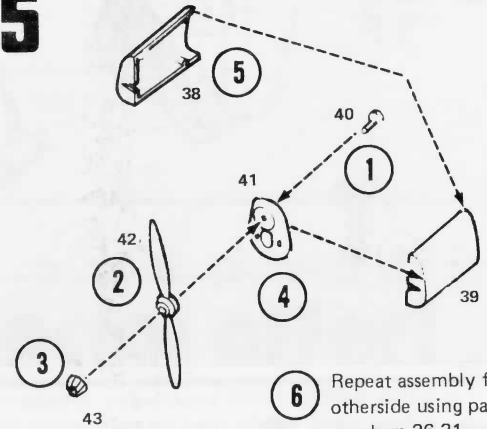

6 Repeat assembly for
otherside using part
numbers 26-31

6

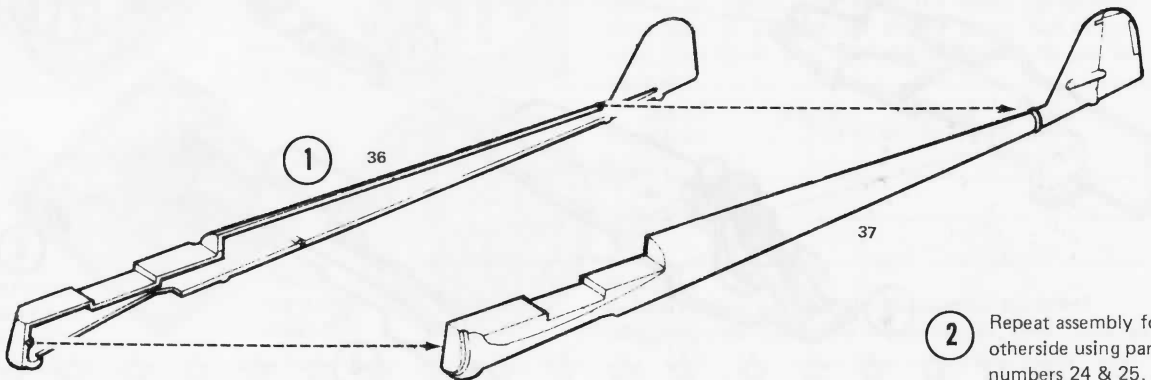

2 Repeat assembly for
otherside using part
numbers 24 & 25.

7

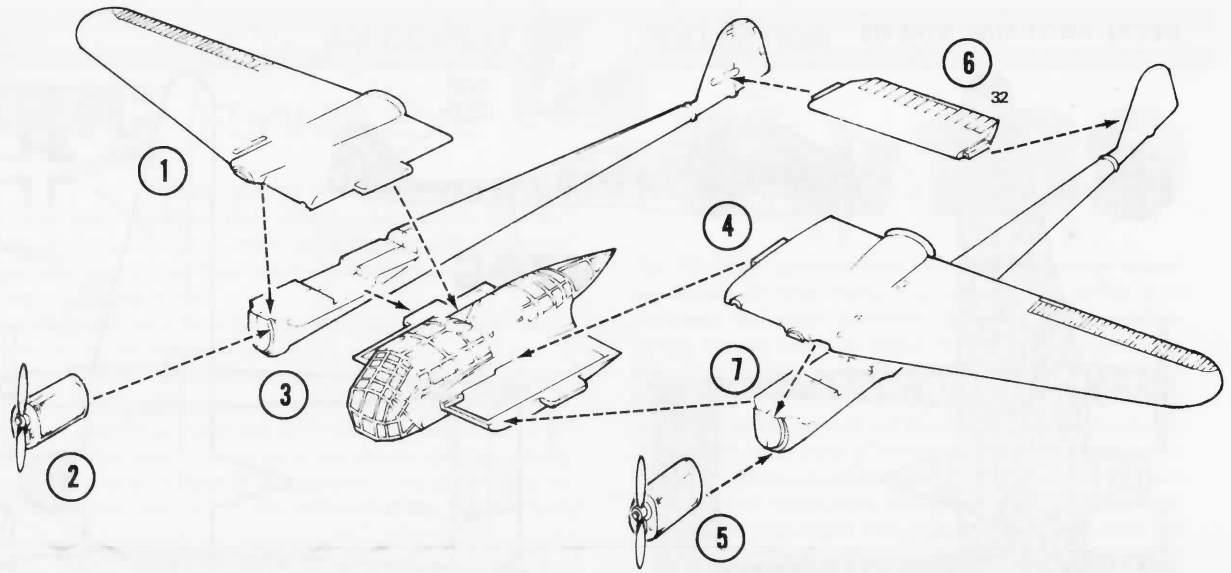

8

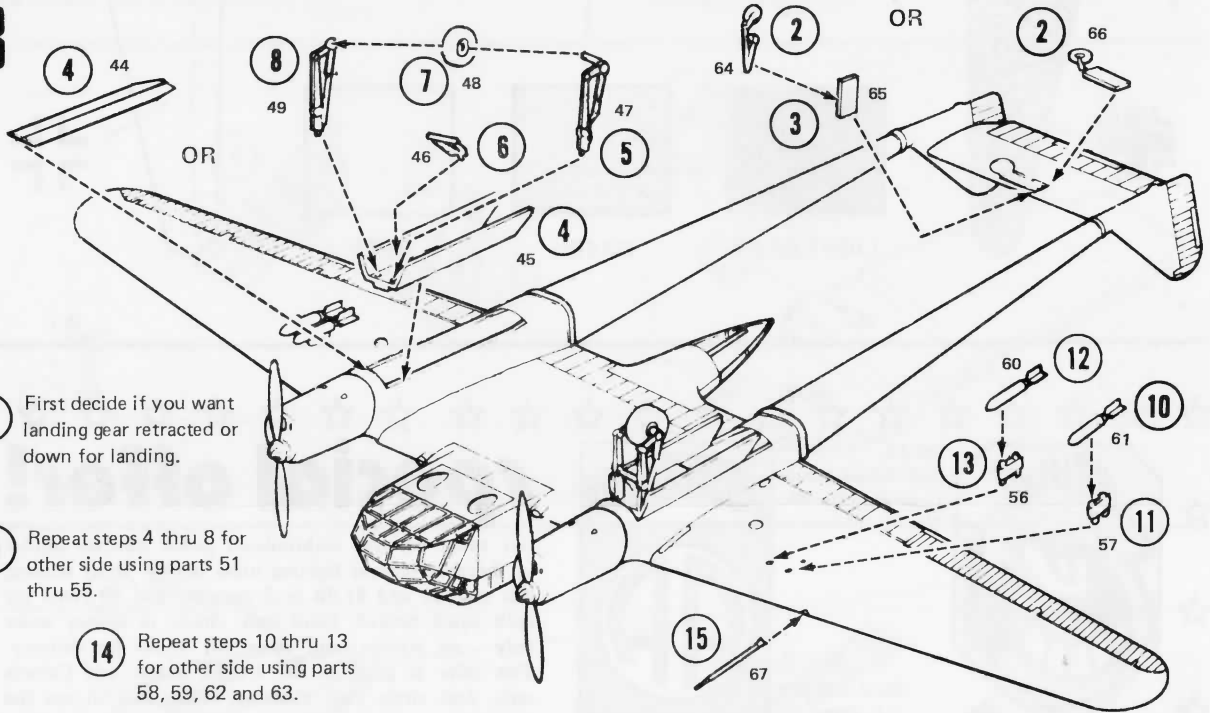

1 First decide if you want landing gear retracted or down for landing.

9 Repeat steps 4 thru 8 for other side using parts 51 thru 55.

14 Repeat steps 10 thru 13 for other side using parts 58, 59, 62 and 63.

FIGURE PAINT SCHEME

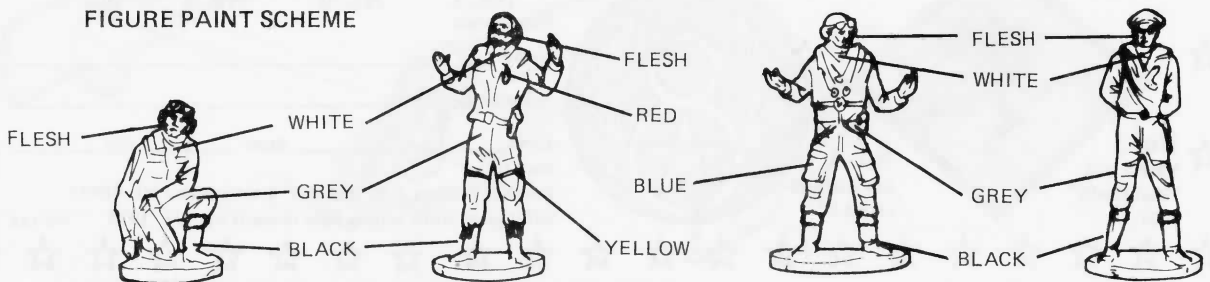

DECAL AND PAINT SCHEME

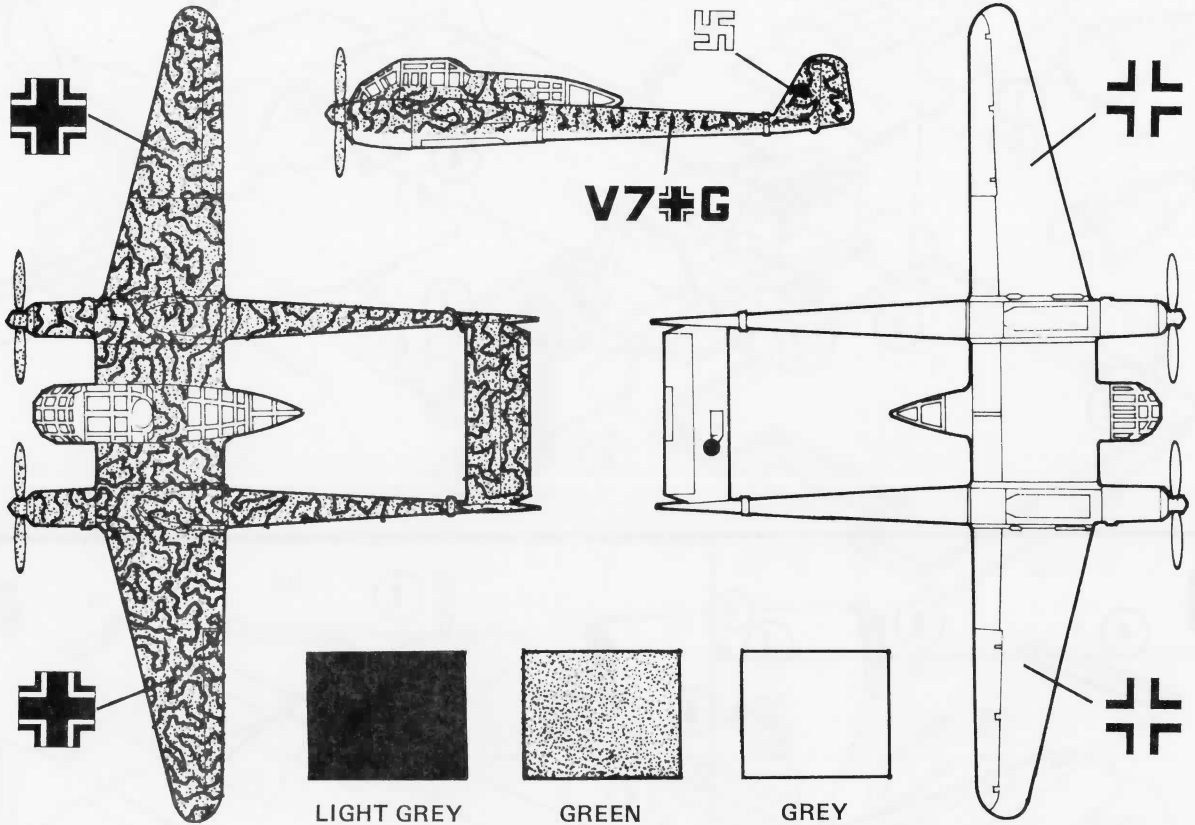

9th JG
54th fighter group
German Luftwaffe
No. 1



No. 2
82nd Airborne
U.S. Army



No. 3
VMFA 232
"Red Devils"
USN



No. 4
8th Airforce
USAAF

special offer!

Get these colorful embroidered jacket patches similar to those of famous fighting units of WW II by sending this coupon and \$1.00 or 2 coupons and 50 cents for each patch desired. Send cash, check, or money order only no stamps, and allow (6) weeks for delivery. This offer is good in the United States and Canada only. Just circle your choice(s) below and fill out the coupon.

No. 1 No. 2 No. 3 No. 4
 Please print
 Name _____
 Address _____
 City _____ State _____ Zip _____

Mail to:
 Combat Patches P.O. Box 767 Mt. Clemens, MI. 48043
 Offer good while supply lasts or until Dec. 31, 1978 FW-189

