

35 K07

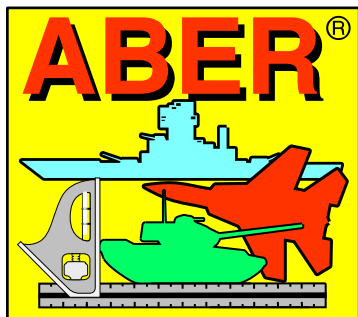

EXCLUSIVE EDITION

UPGRADE SET FOR TAMIYA 1/35 MODEL

Can be used to models of Jagdtiger another producers

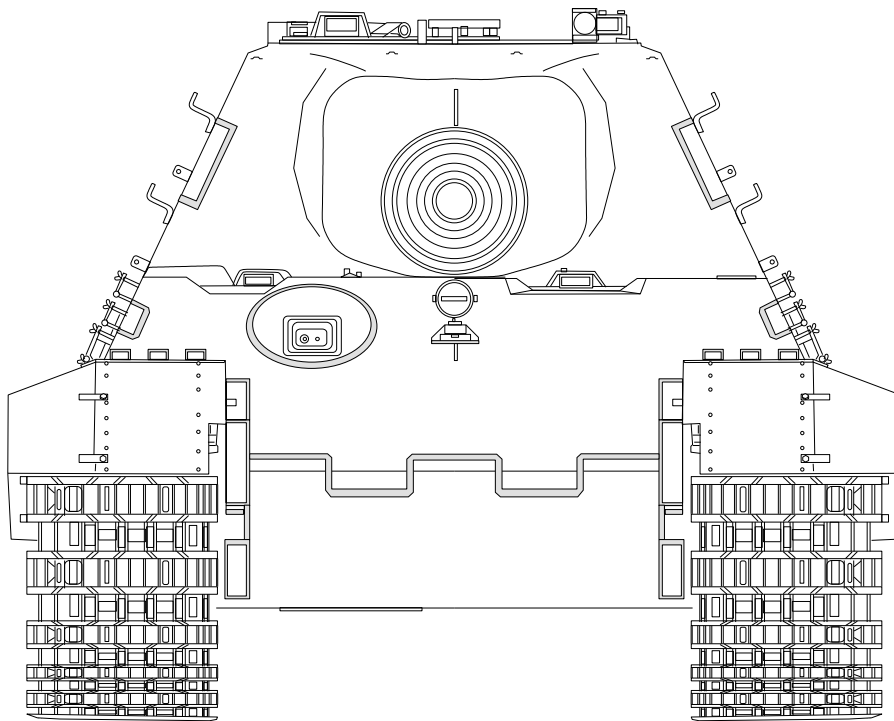

GERMAN HEAVY TANK DESTROYER Panzerjäger "JAGDTIGER" (Sd.Kfz. 186) Frühe Produktion

Niemiecki ciężki niszczyciel czołgów Jagdtiger

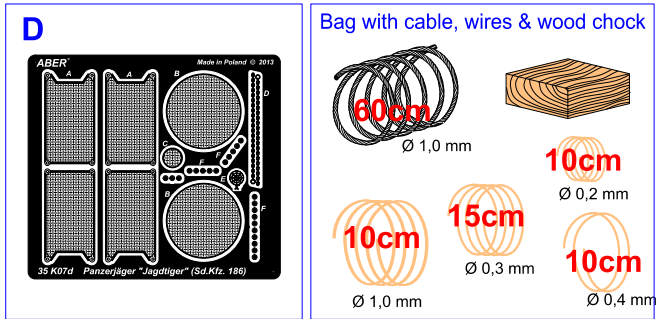
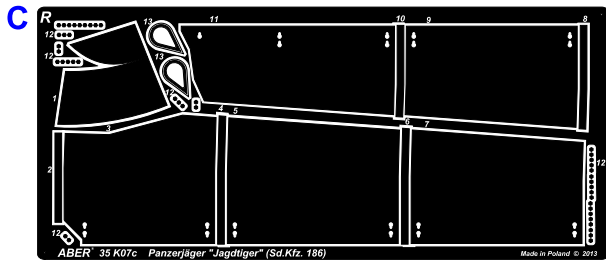
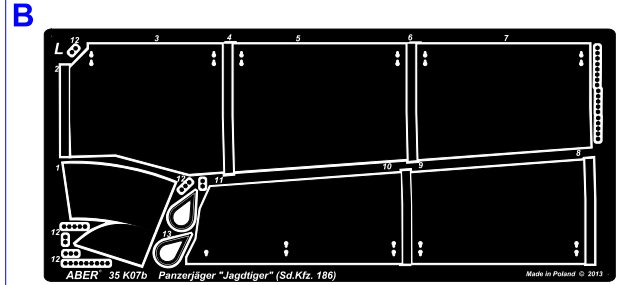
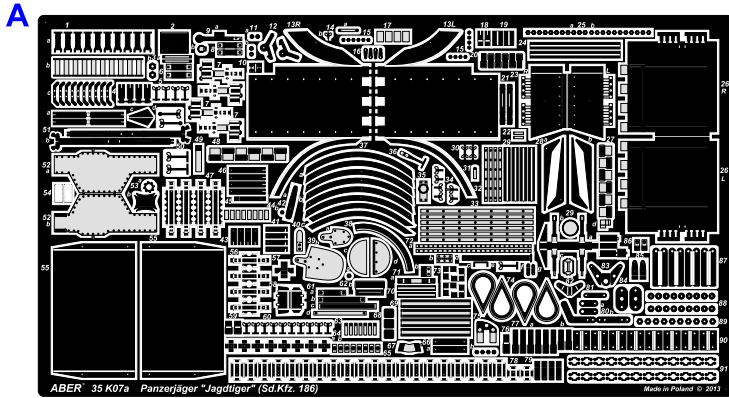

Bag with ABER barrels, antennas, tubes and rods

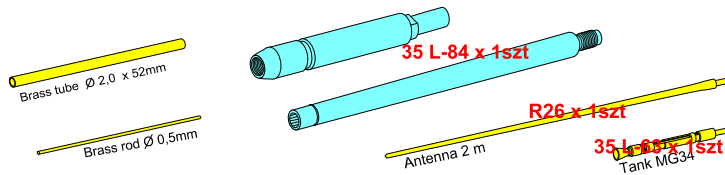

Turned parts

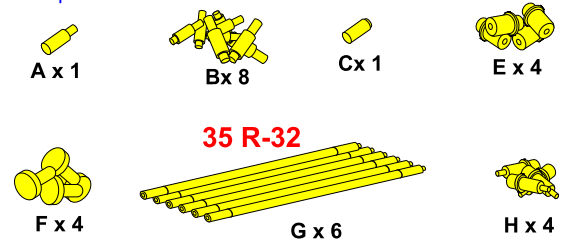

MOST IMPORTANT BIBLIGRAPHY:

- 1) Achtung Panzer No.6 - Panzerkampfwagen Tiger by Mitsuru Bitoh
- Dai Nippon Kaiga Co.,Ltd. ©1999
- 2) GROUND POWER No. 017, 052, - Delta Publishing Co.,Ltd. ©1995; ©1998
- 3) Militärfahrzeuge Band 7; Der Panzer-Kampfwagen Tiger und Seine Abarten -
Walter J. Spielberger - Motorbuch ©1994
- 4) Schwere Panzer in Detail - B. Culver & U. Feist - Ryton Publications ©1998
- 5) AFV Modeling Guide Vol.4 - Schwere Jagdpanzer - Geibun Mooks No.706
- 6) Panzer Tracts No.9 - Jagdpanzer -Jagdpanzer 38 to Jagdtiger
- Thomas L. Jenz & Hilary Louis Doyle - Darlington Productions, Inc. ©1997

Thank you for purchase our set **35 K07**.

Read carefully this instruction.

We advise that better method to join metal to metal parts is soldering.

Cement metal parts to plastic with good cyanoacryl or epoxy glue.

WARNING

Any unauthorized copying, producing and reproducing of ABER company products, or any part thereof, is strictly prohibited and any such action establishes liability for a civil action and may give rise to criminal prosecution.

OSTRZEŻENIE

Jakiegokolwiek kopiowanie, produkowanie i reprodukcja wyrobów firmy ABER bez zezwolenia, w całości lub części jest surowo zabronione. Powyższe działania powodują powstanie odpowiedzialności cywilnej oraz mogą spowodować wszczęcie postępowania karnego.

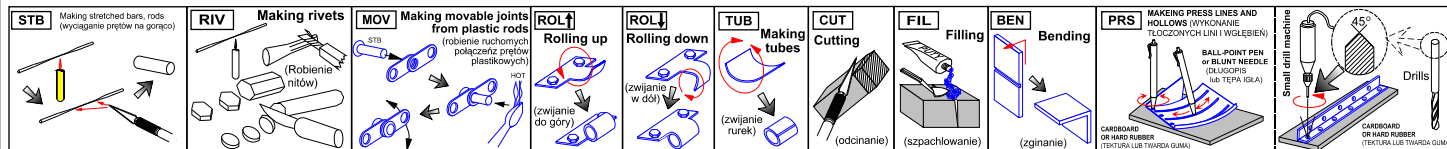

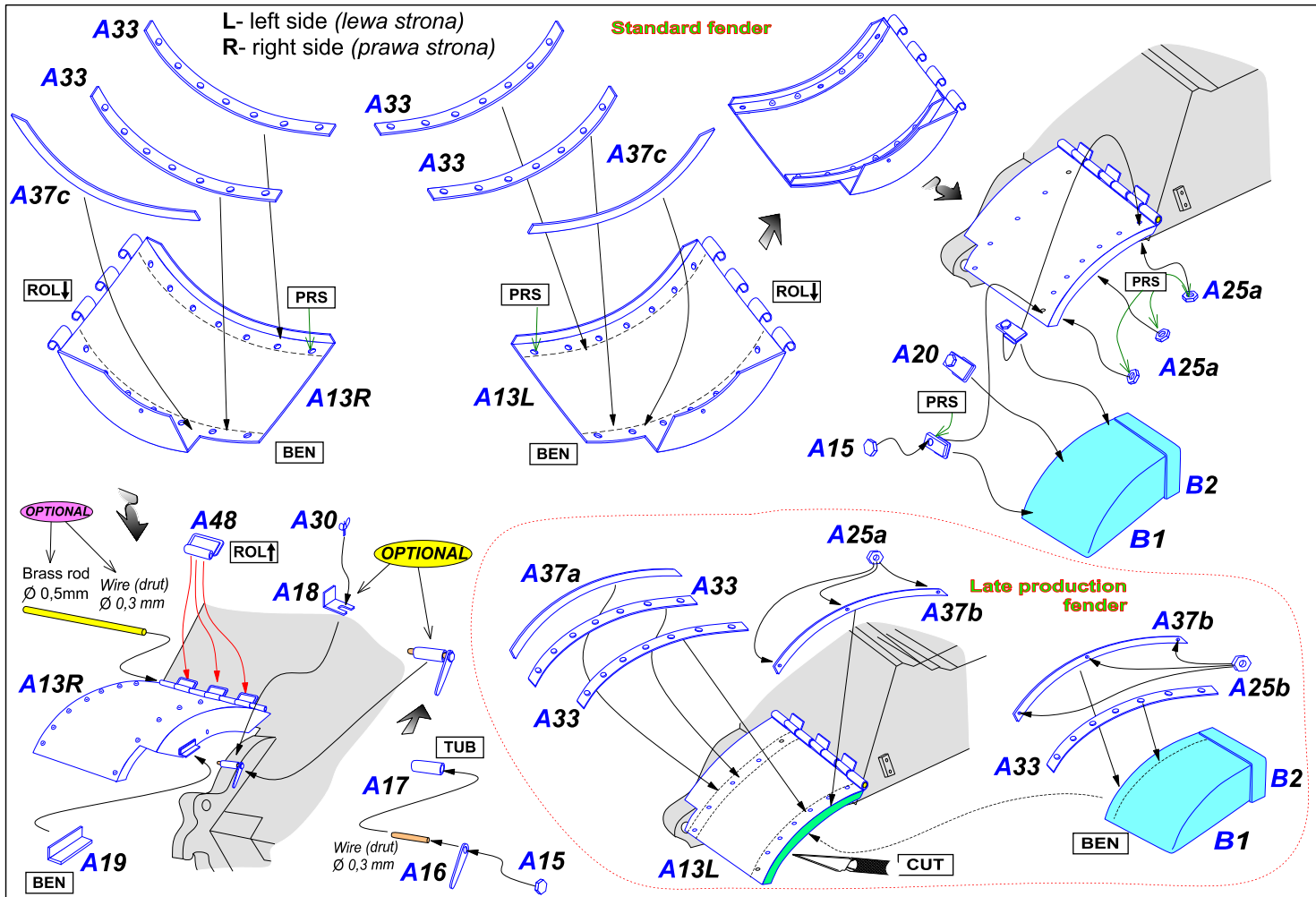

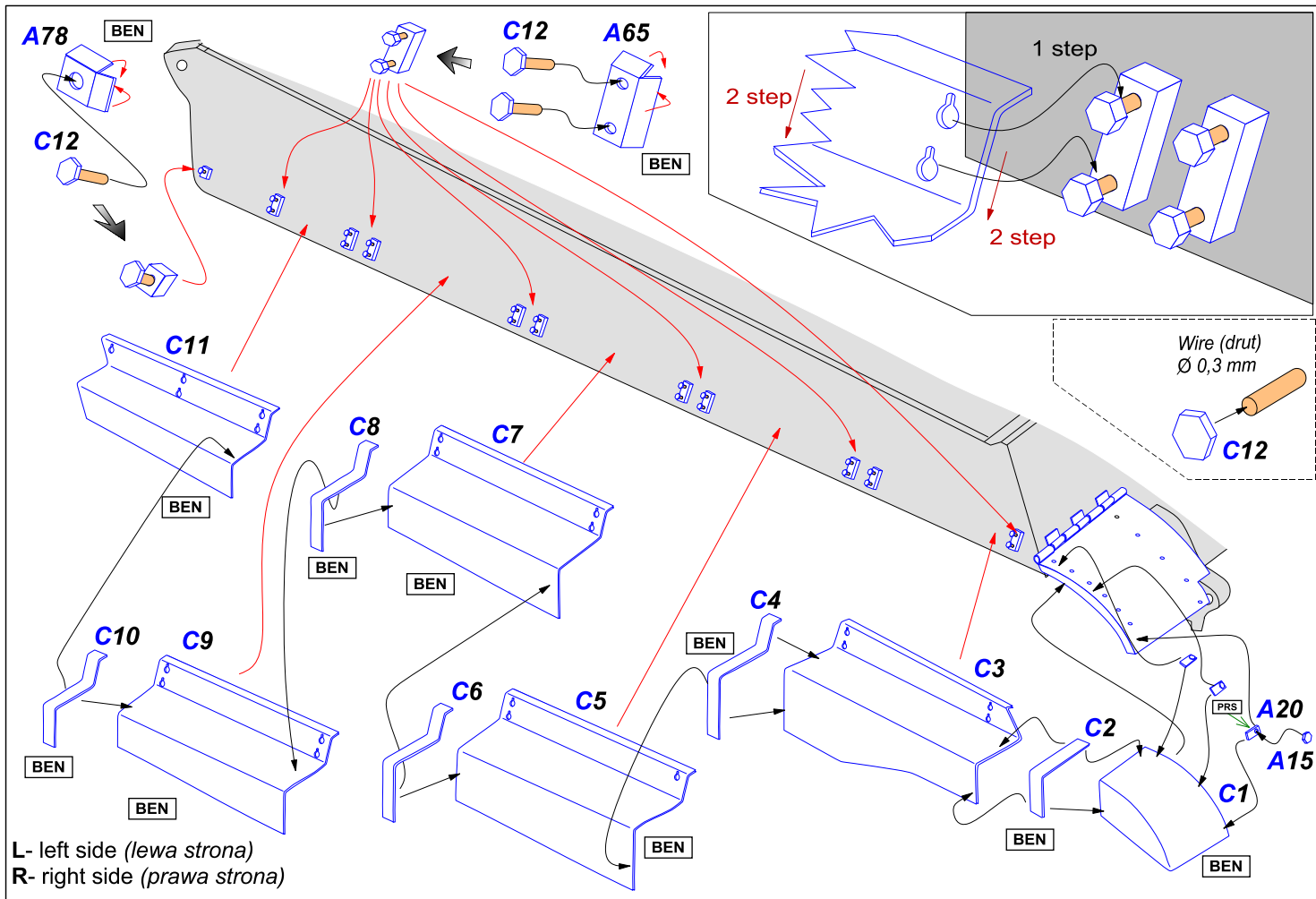

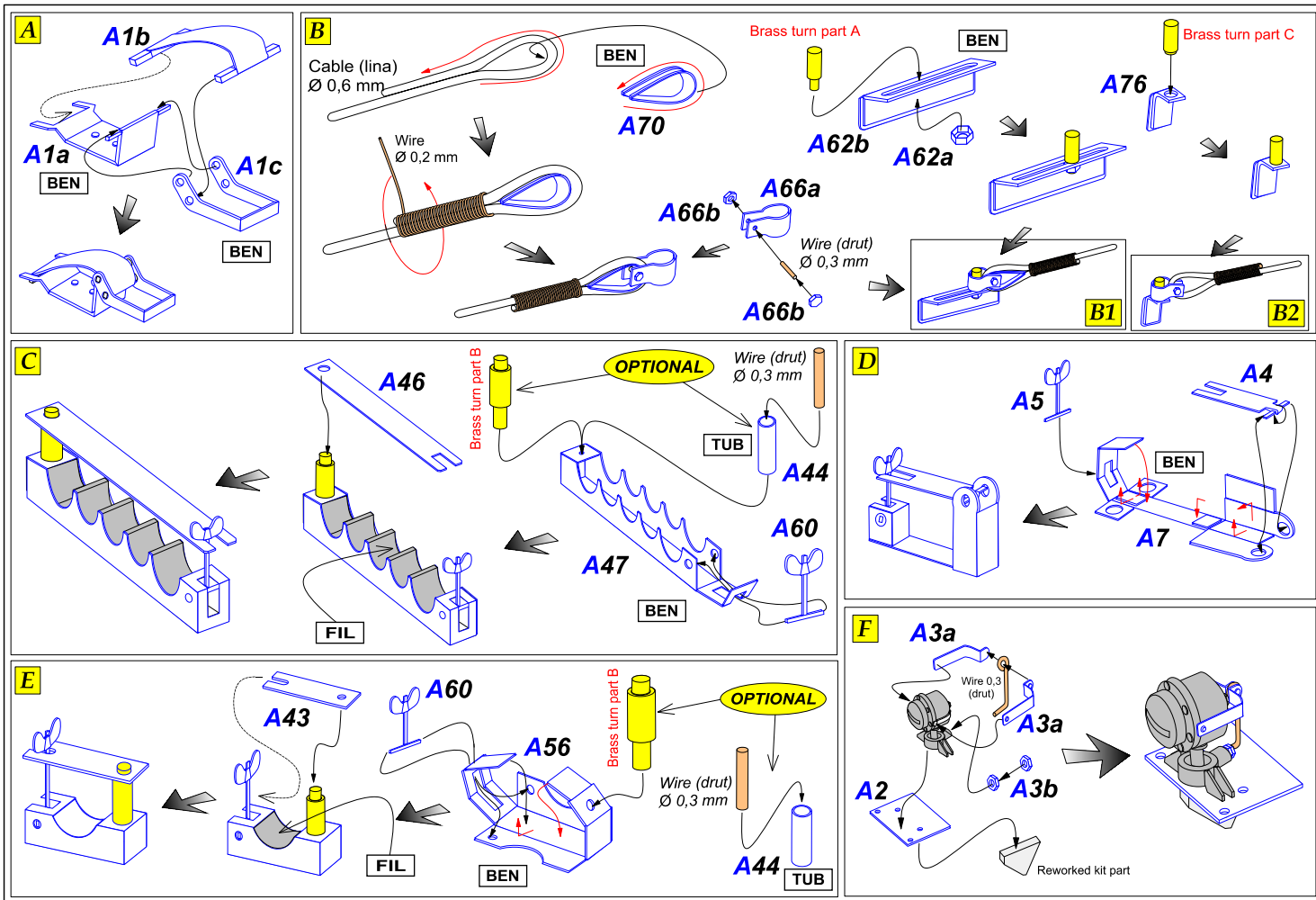

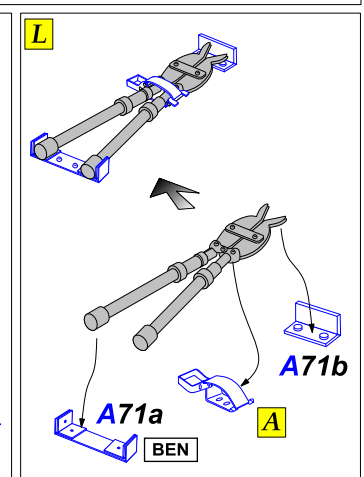
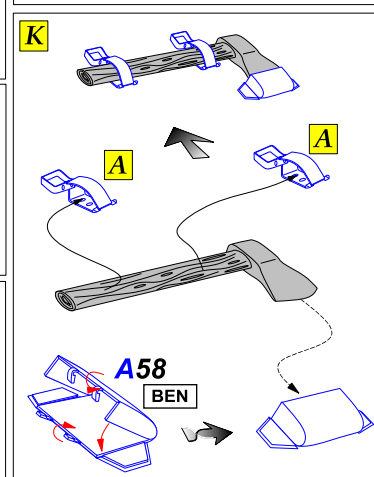
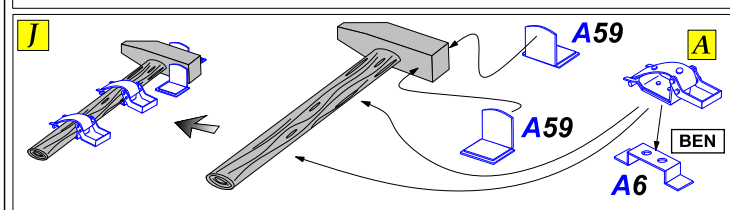
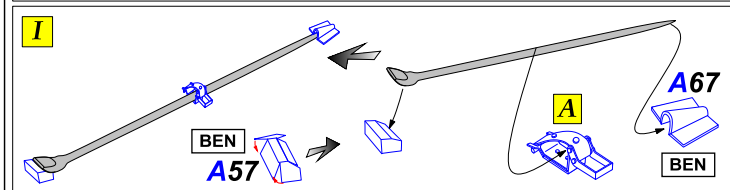
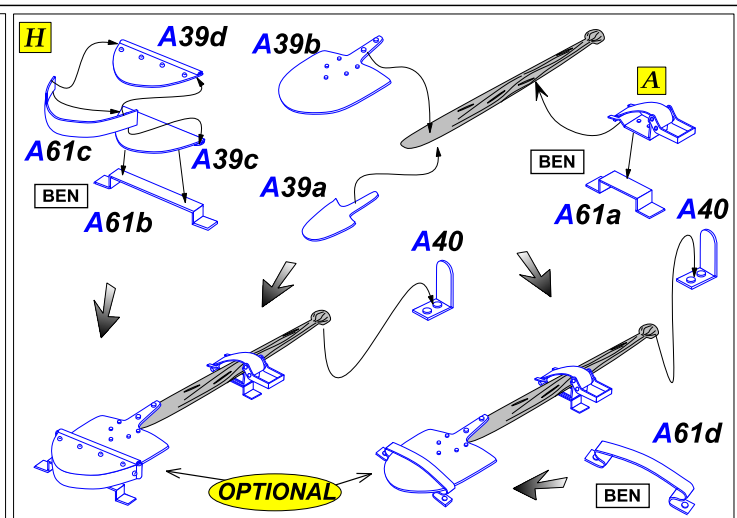
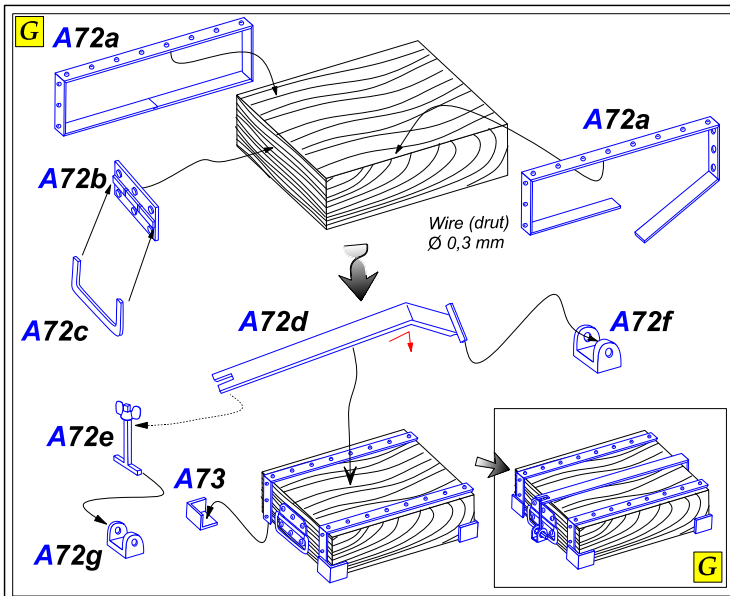

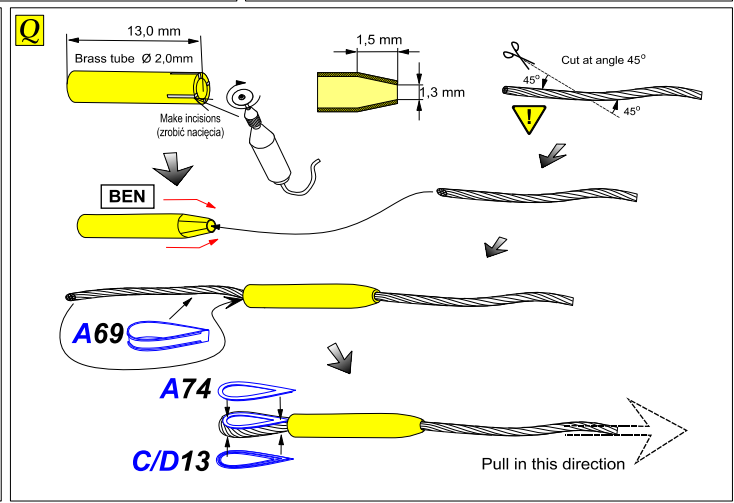
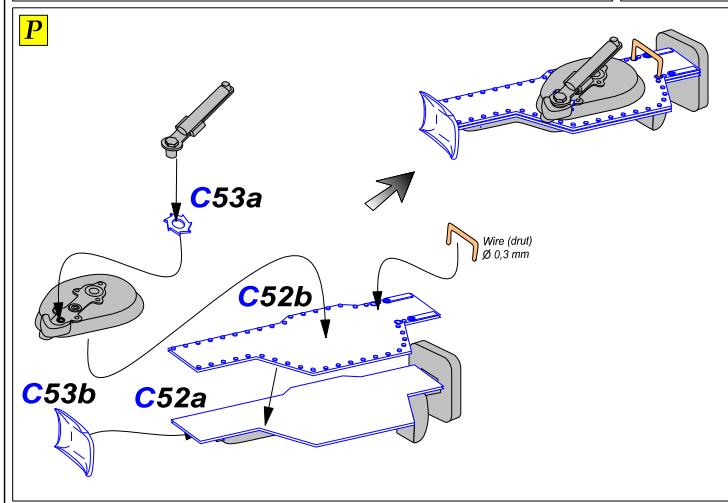
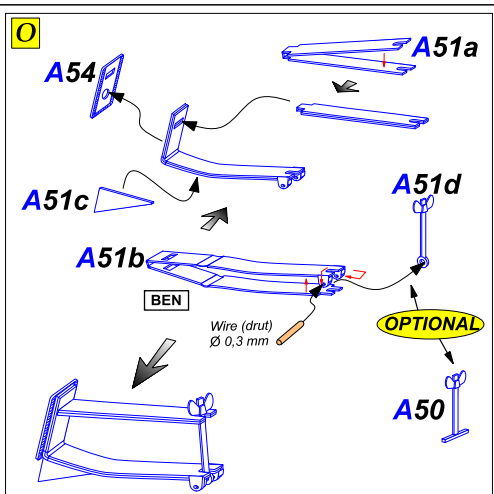
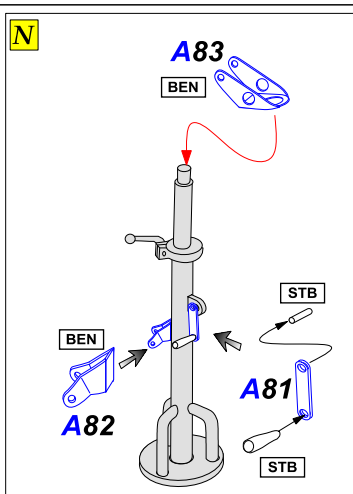
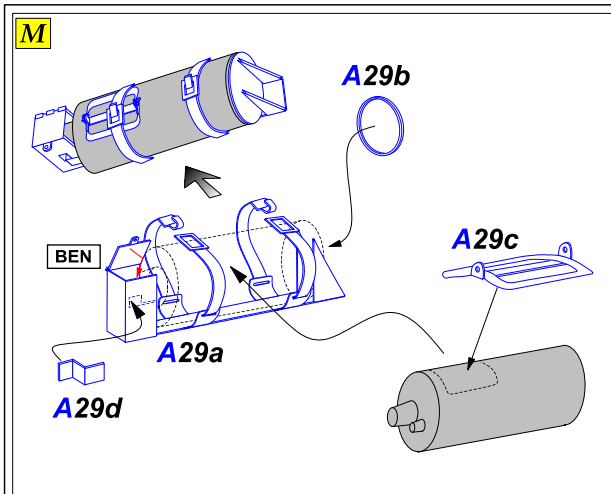

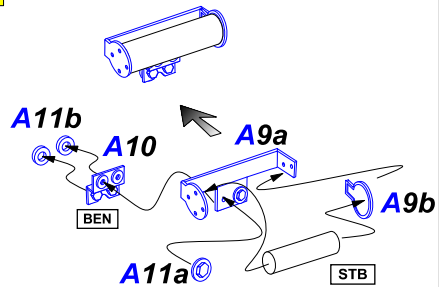
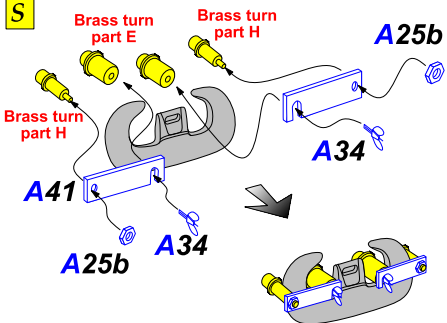
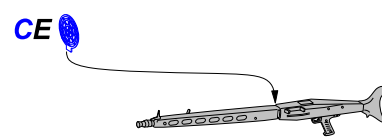
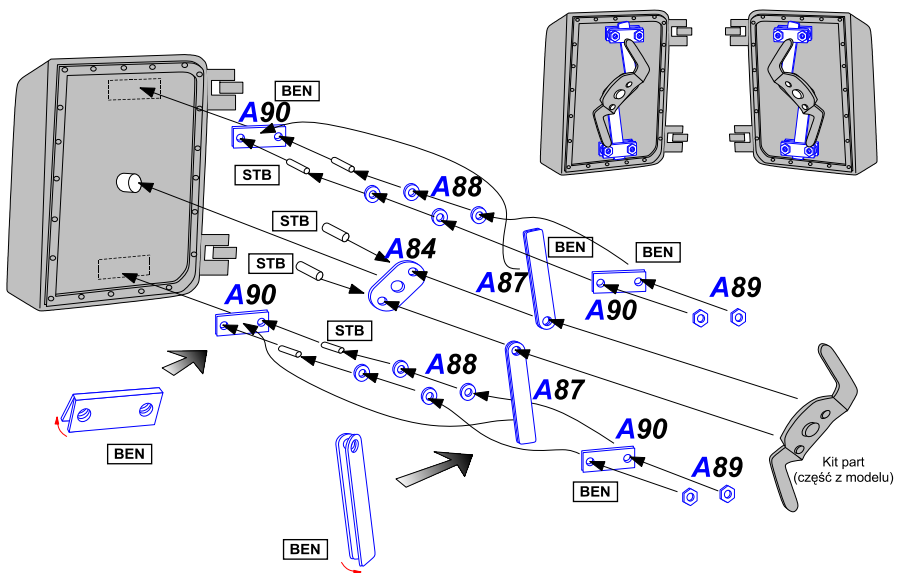
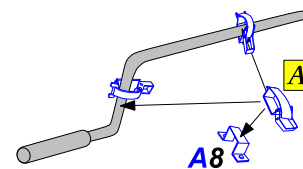
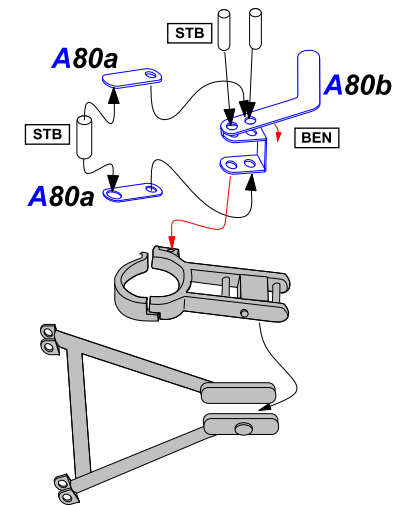
R**S****T****U****GUN TRAVEL LOCK**

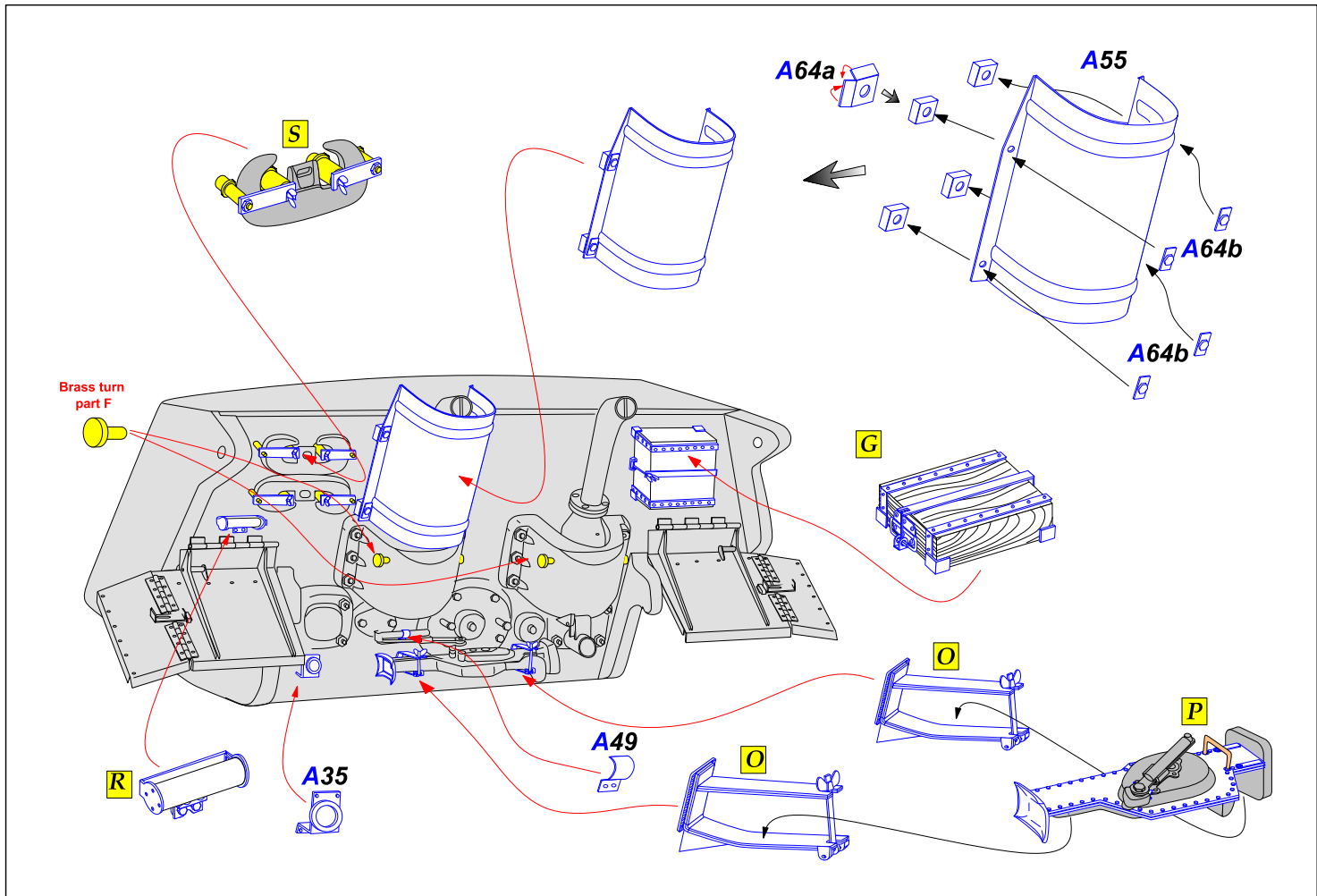

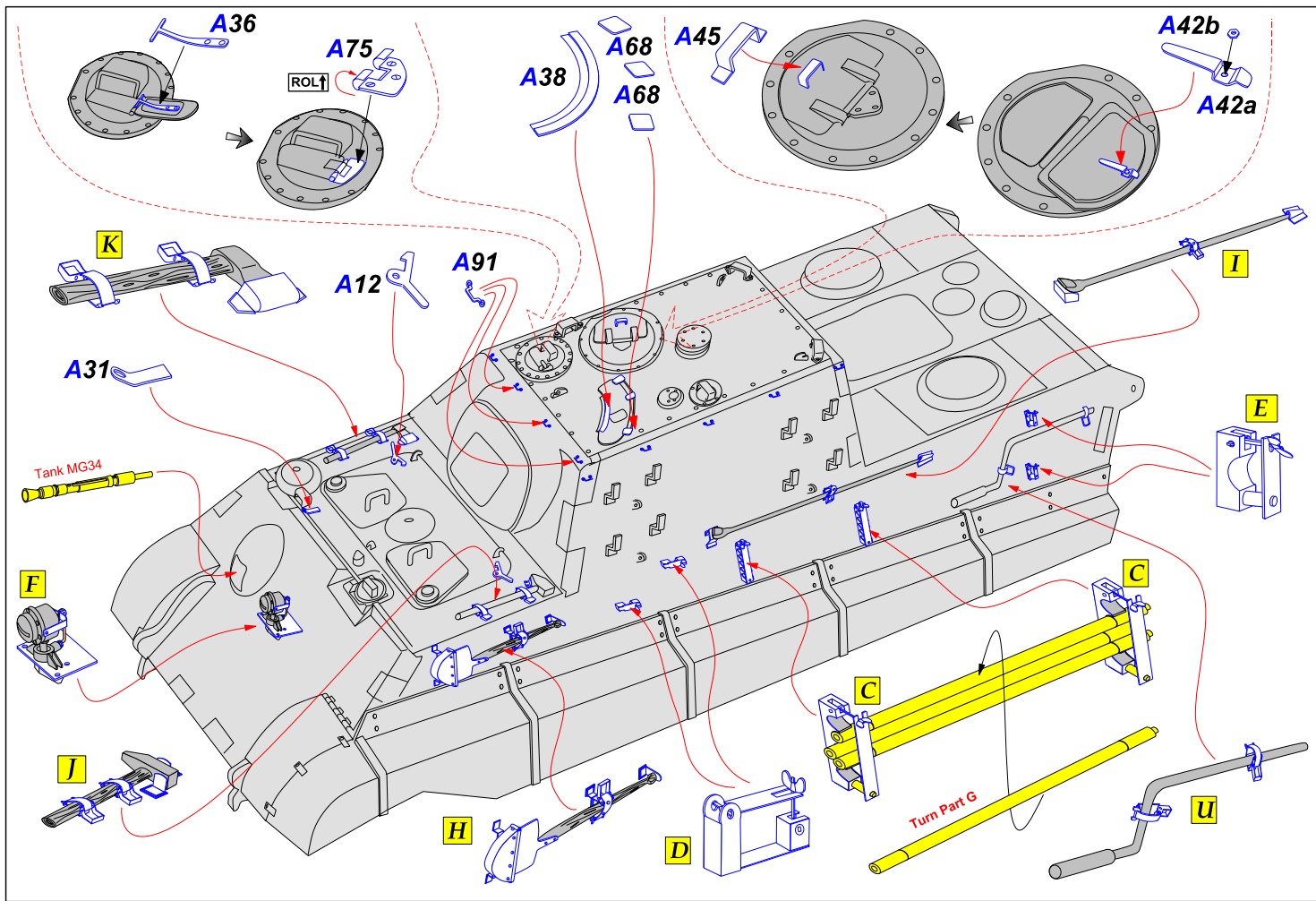

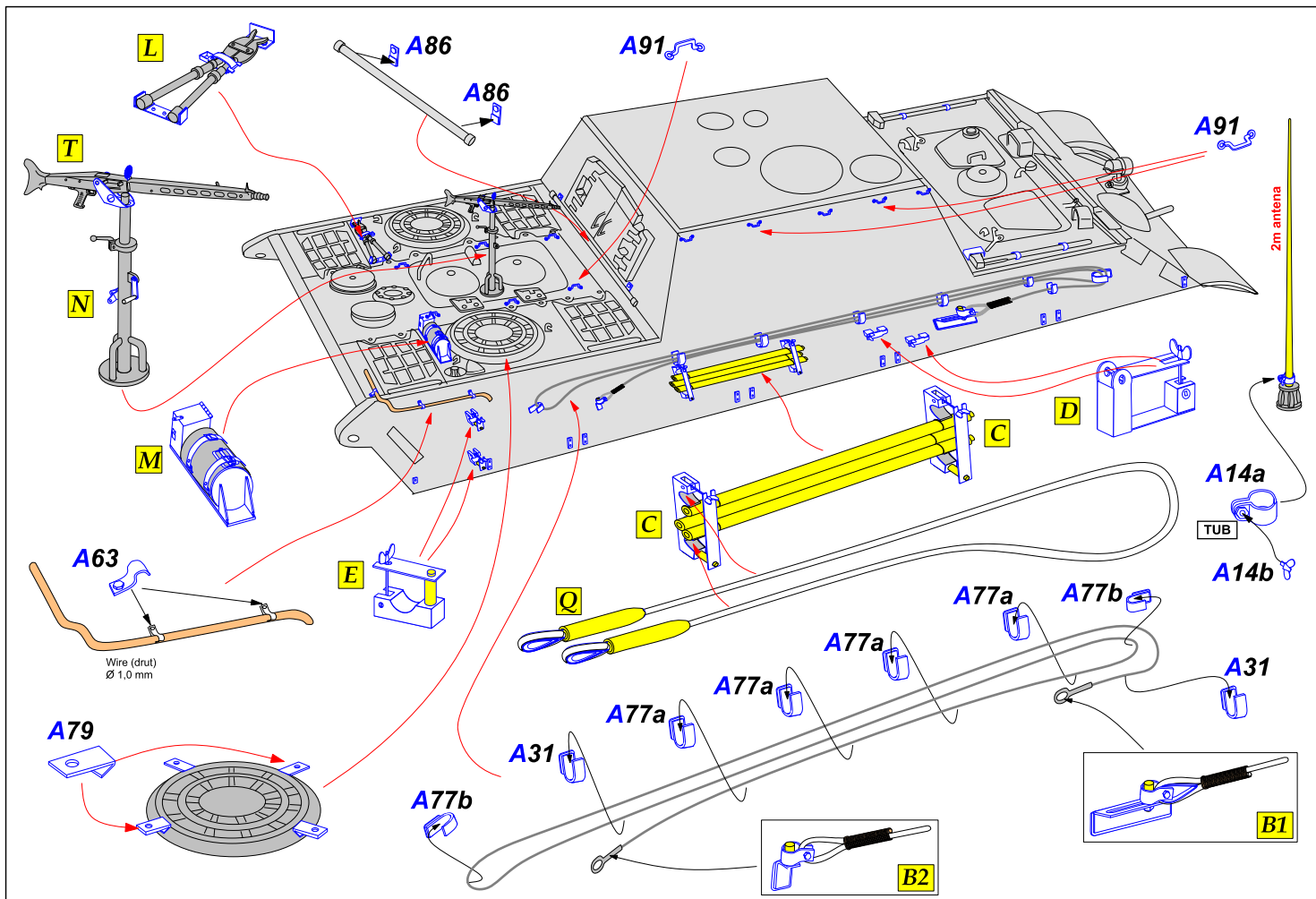

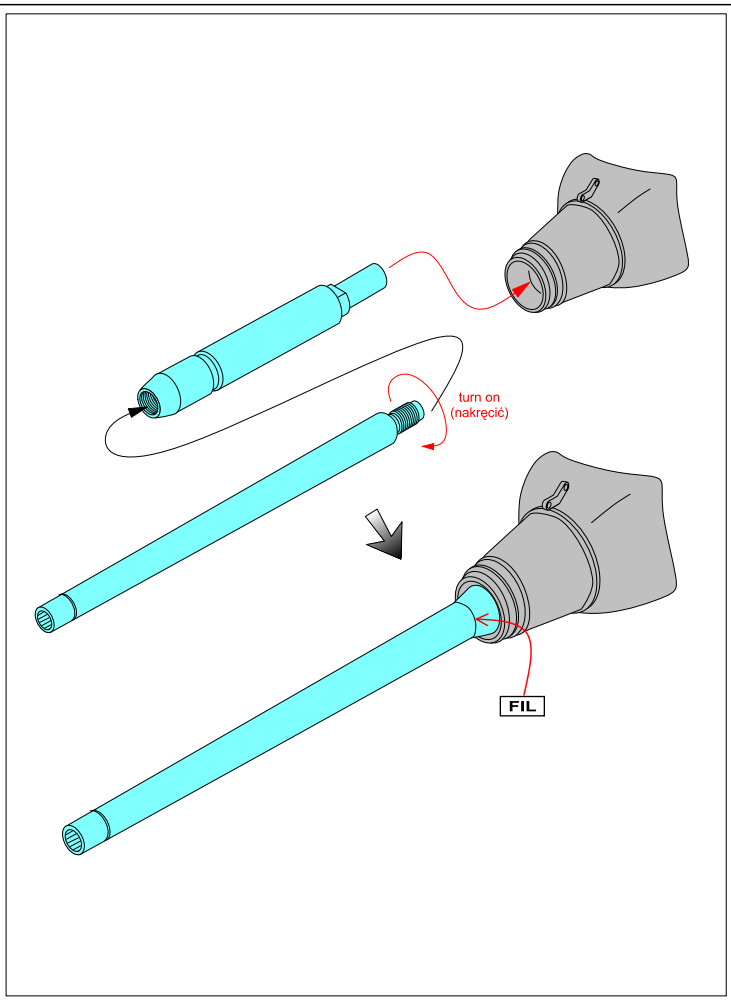
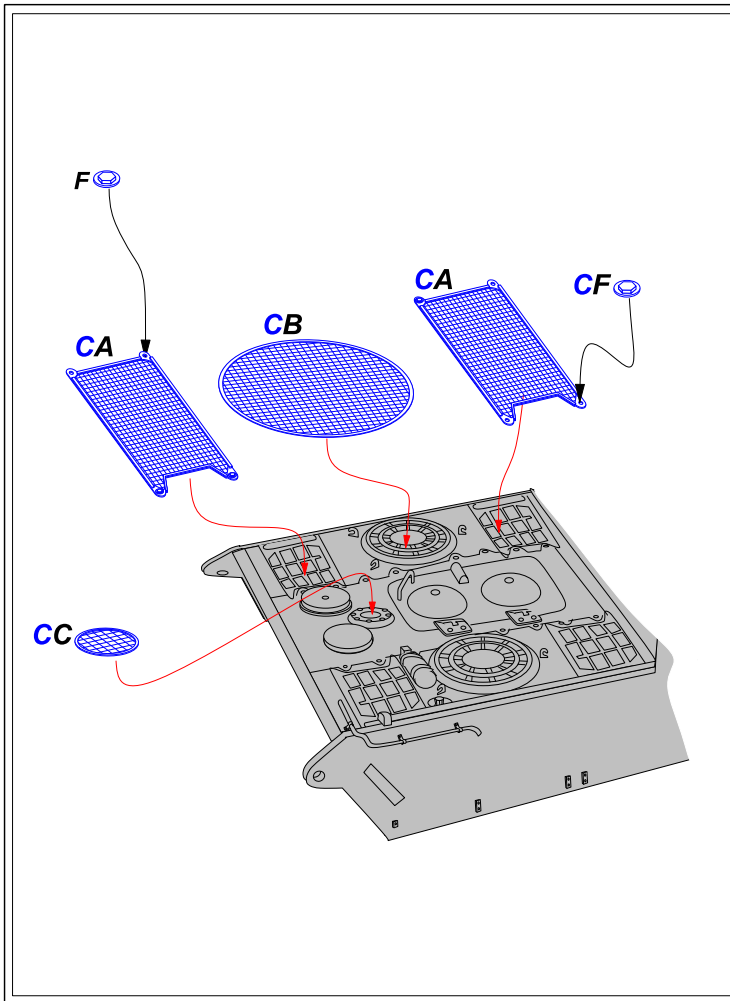

TOOLS RECOMMENDED

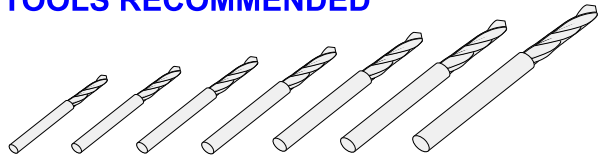

Drills from \varnothing 0,4 to 1,5 mm

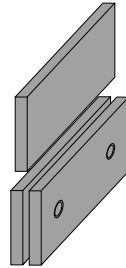

Bending tool
PG01 or PG02

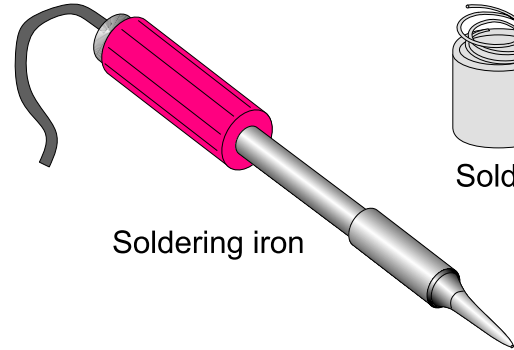

Soldering iron

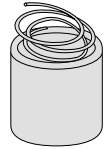

Solder



Assortiment of cutting wheels and mills

Light weight
hammer

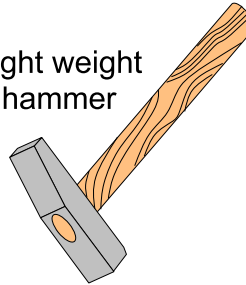

CYANOACRYL
GLUE



EPOXY GLUE



EPOXY GLUE

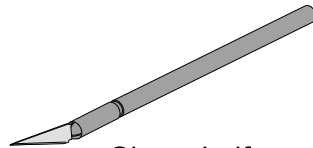

Sharp knife

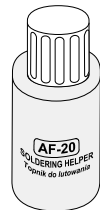

Soldering flux

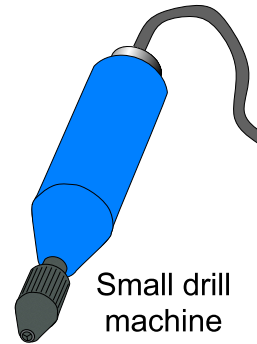

Small drill
machine