

# Rusty Wallace's ALUGARD

## Grand Prix

### INSTRUCTION SYMBOLS

- 2** - step numbers
- 13** - part numbers
- \*106** - plated part numbers

### IMPORTANT - READ THIS FIRST!

- ★ Study assembly drawings carefully before starting.
- ★ Follow step number sequence in each assembly drawing.
- ★ Scrape paint and plating from contact areas to be joined.
- ★ Only use cement made for styrene plastic.
- ★ Check fit before cementing parts together.
- ★ Use cement sparingly.
- ★ Cement all parts except where noted.
- ★ Painting your model is optional.
- ★ Use standard colors where noted.
- ★ Allow paint to dry completely before handling.

©1985 Fundimensions, Division of CPG Products Corp.

# 1

Refer to last step for body painting instructions.

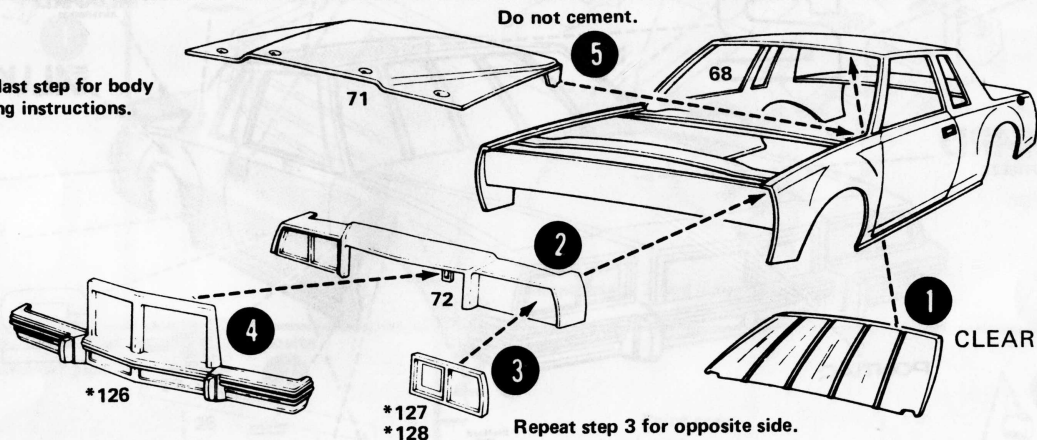

# 2

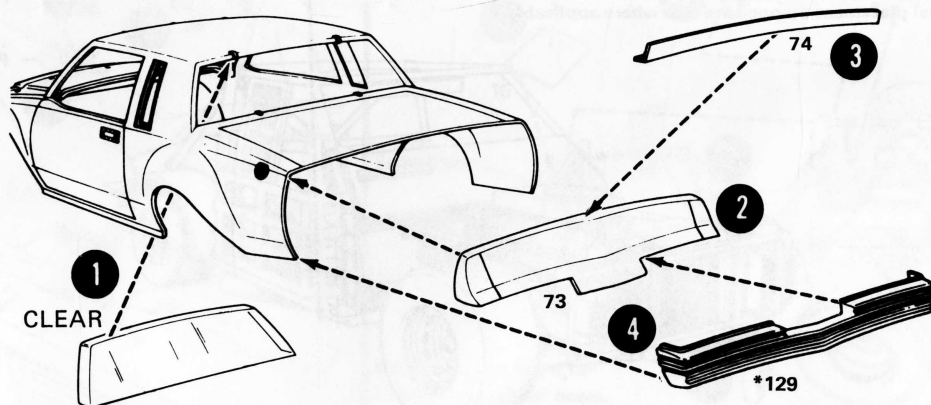

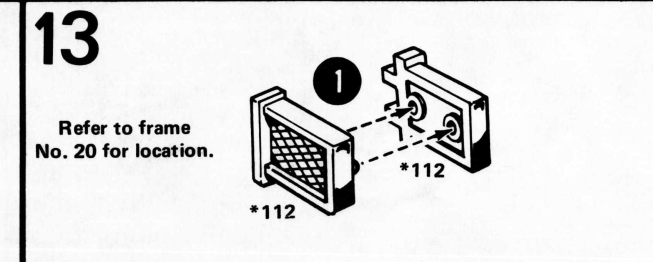
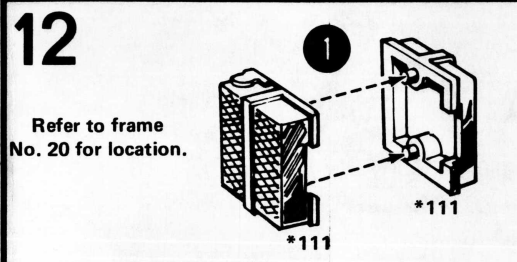
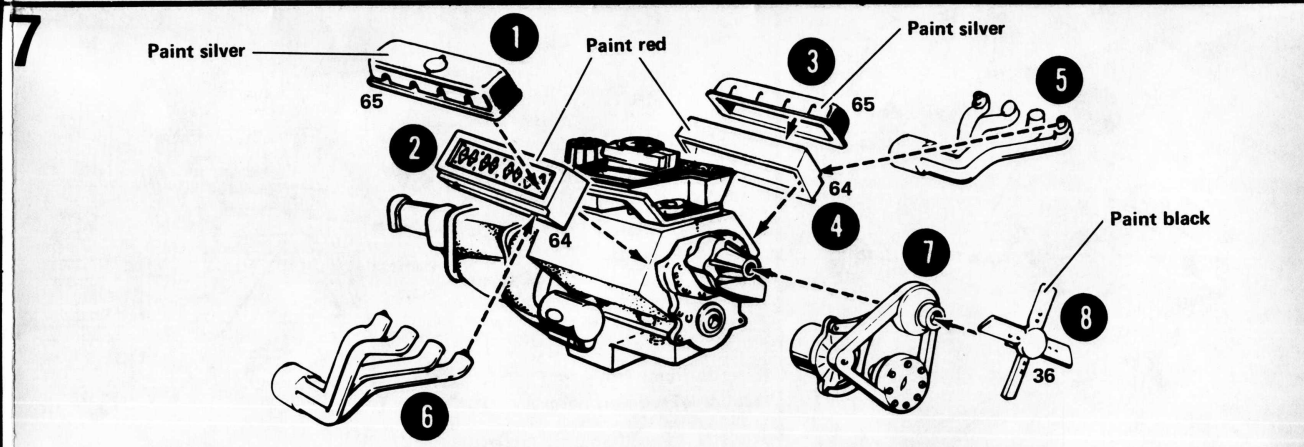
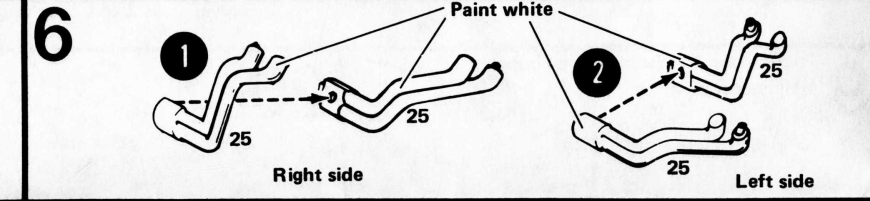
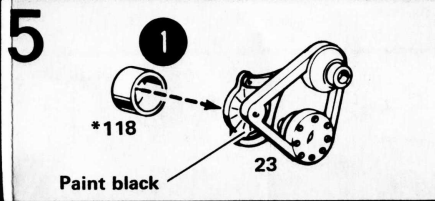
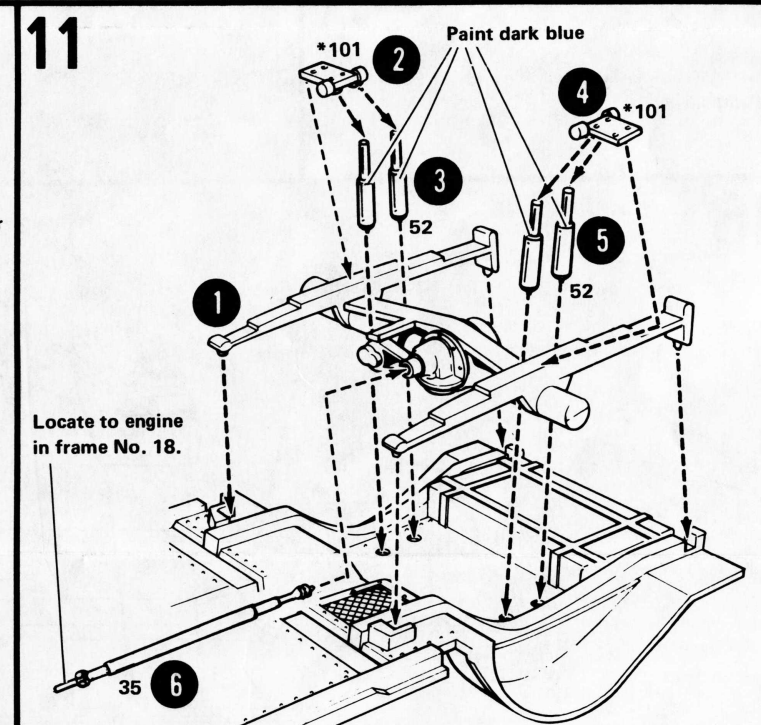
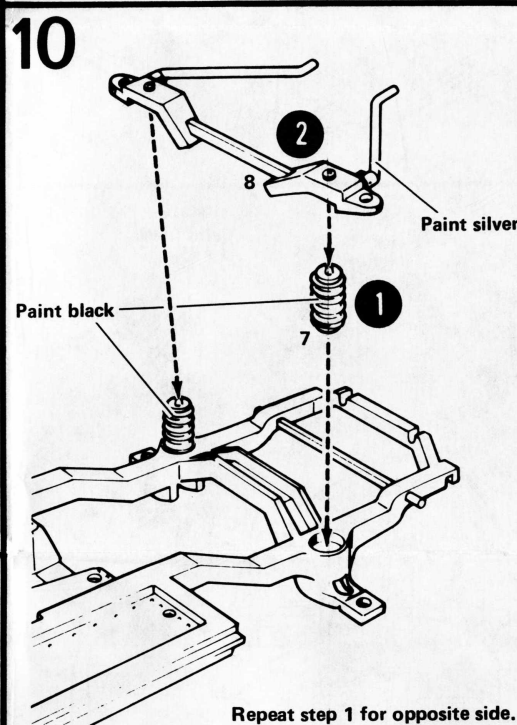
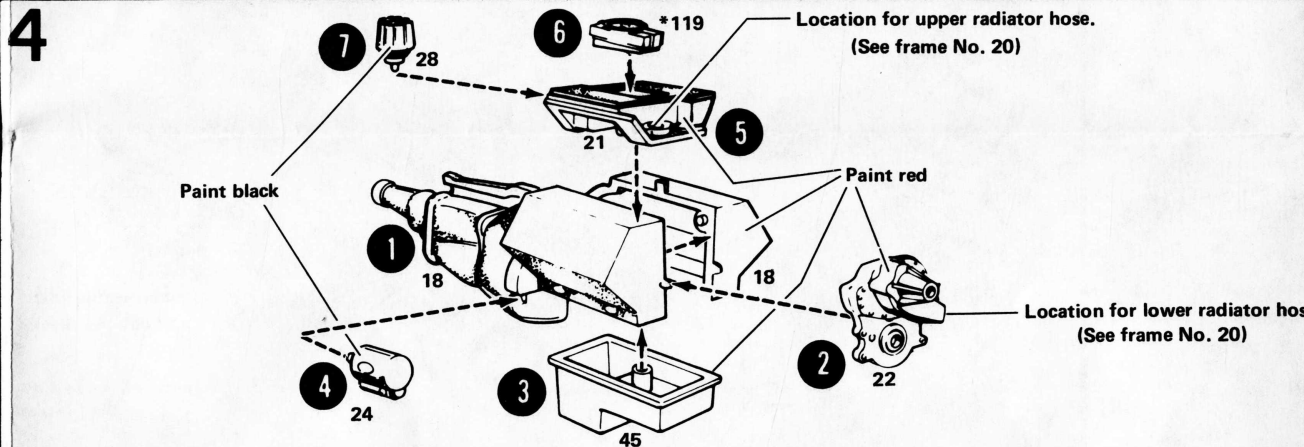
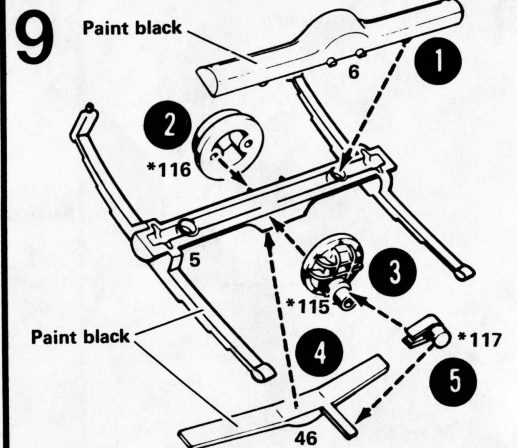
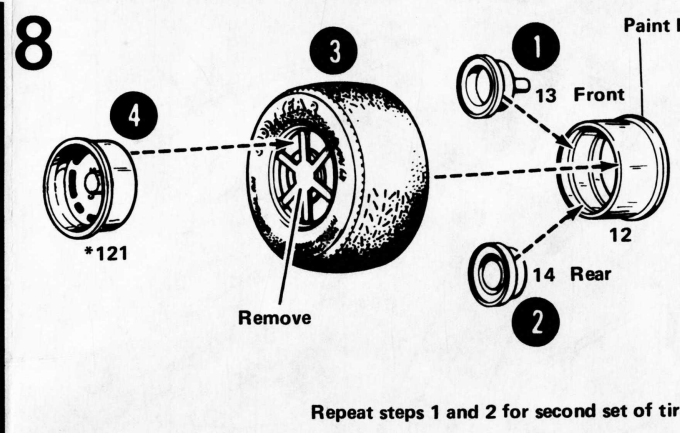
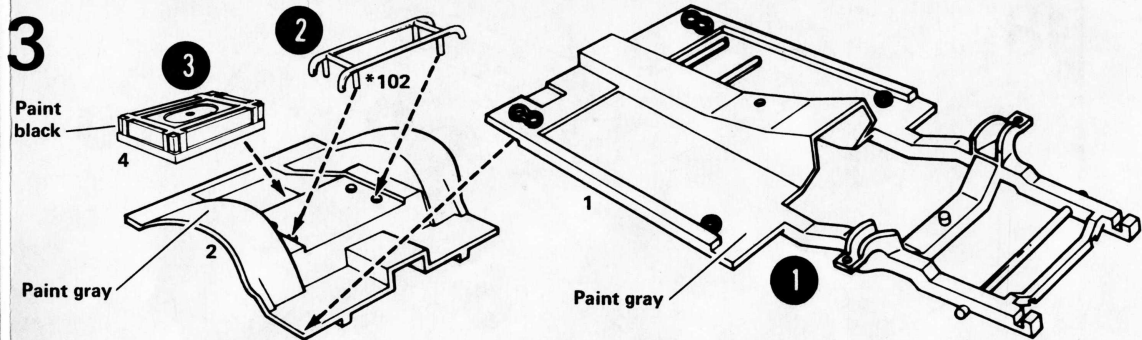



14

Repeat steps 1 through 3 for opposite side.

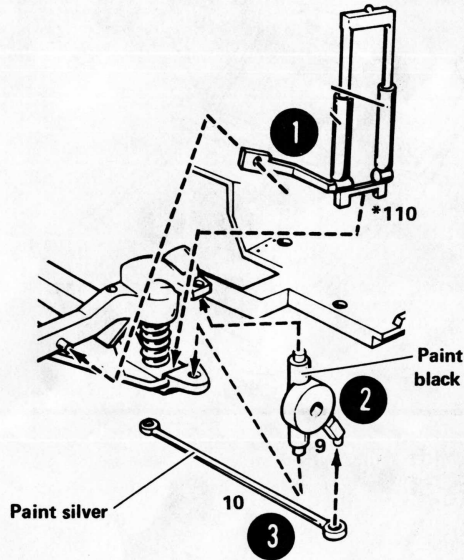

15

Side view for proper firewall assembly.

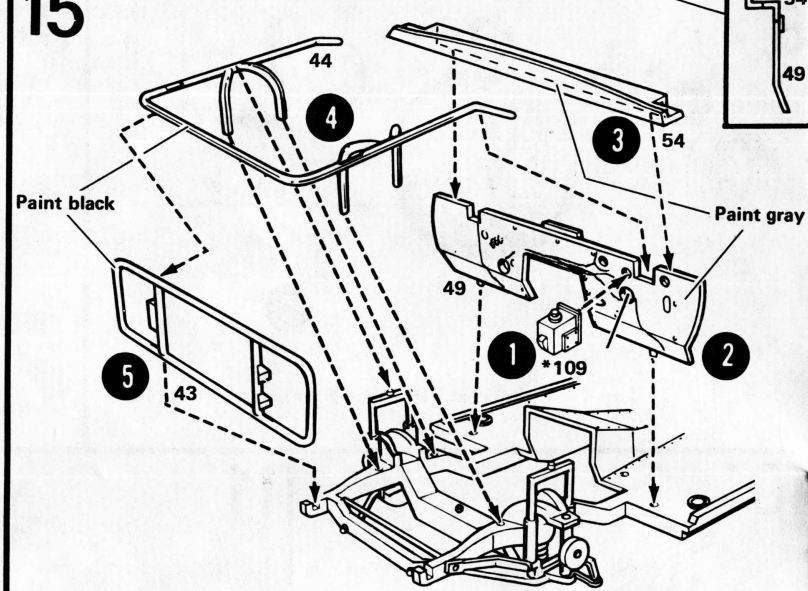

17

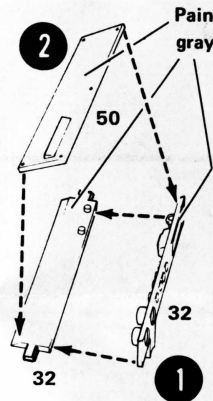

18

Locate to drive shaft.

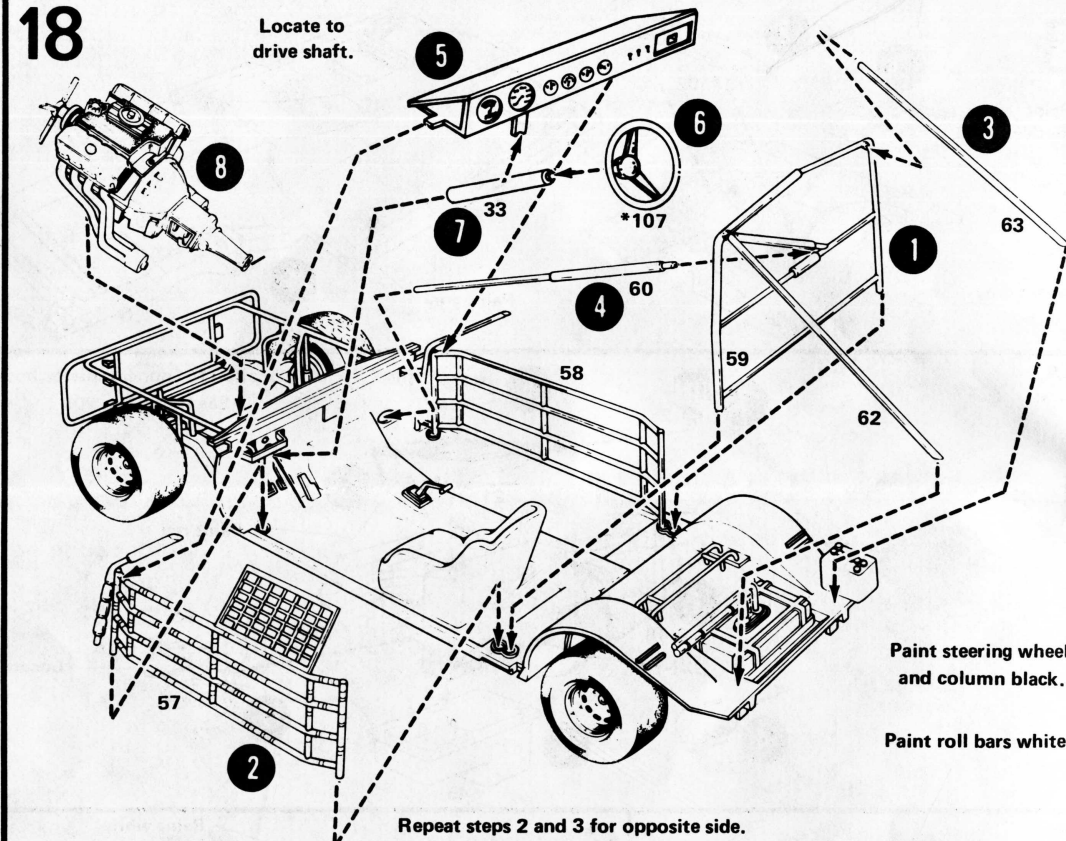

16

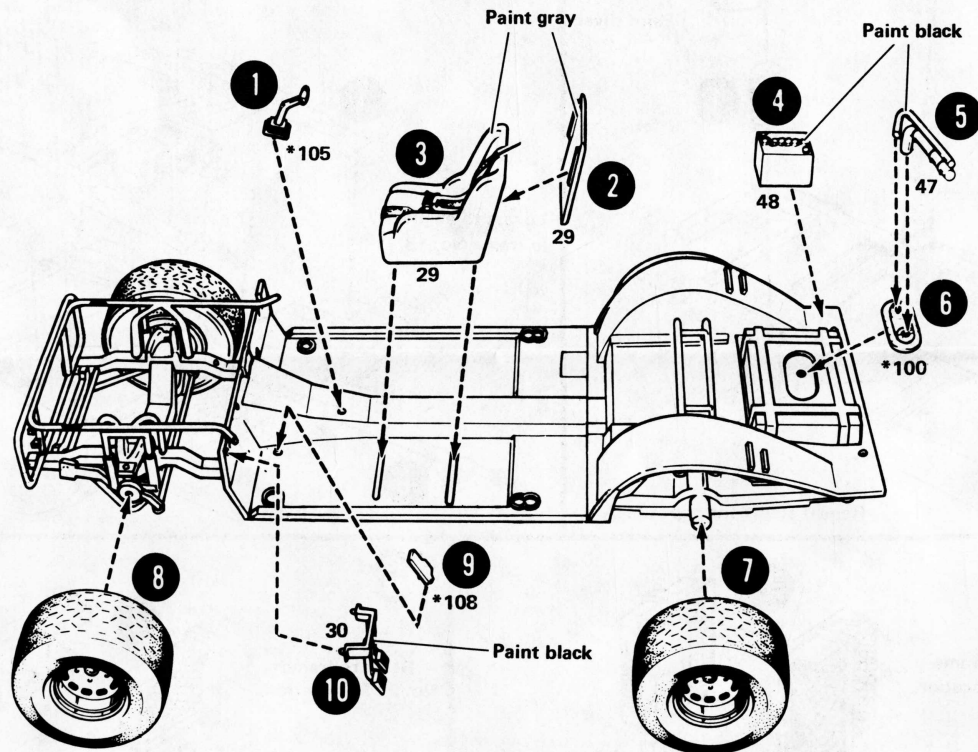

Repeat steps 7 and 8 for opposite side.

19

Repeat step 2 for assembly of opposite exhaust pipe.

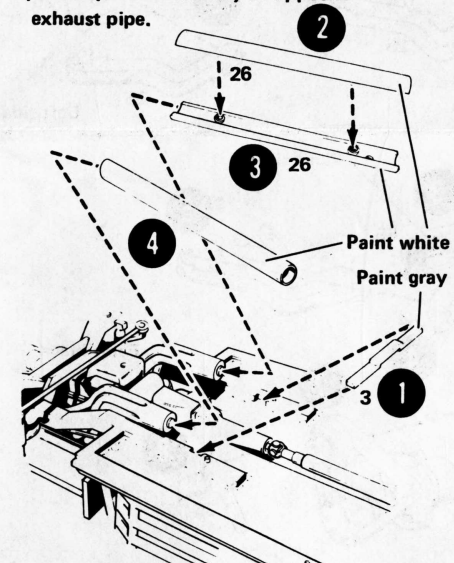

20

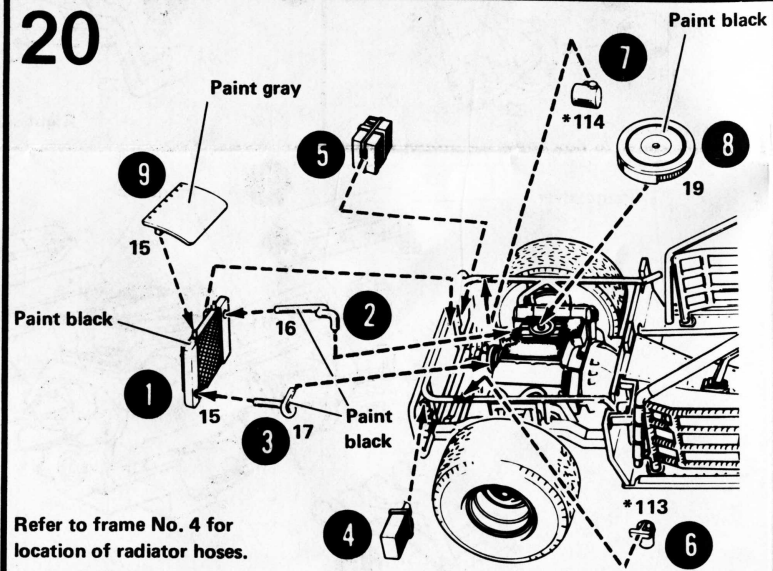

# 21

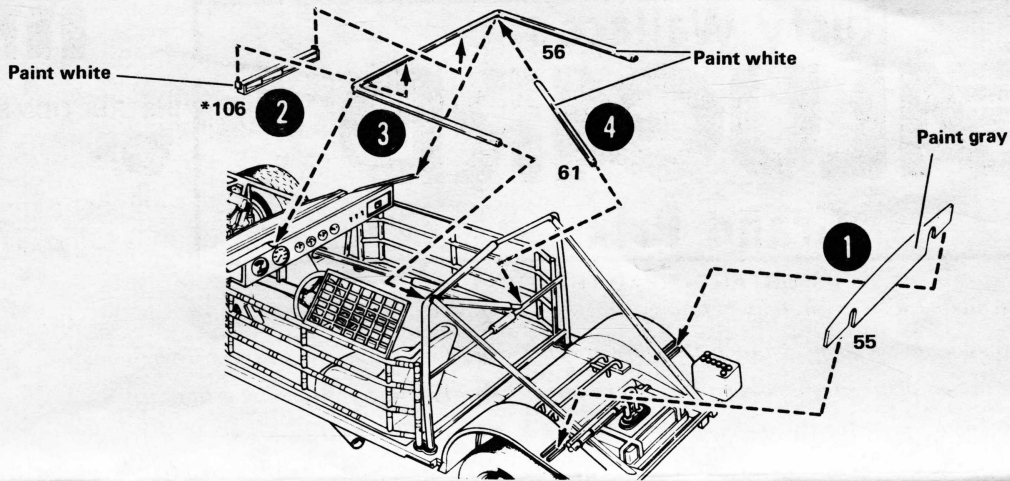

# 22

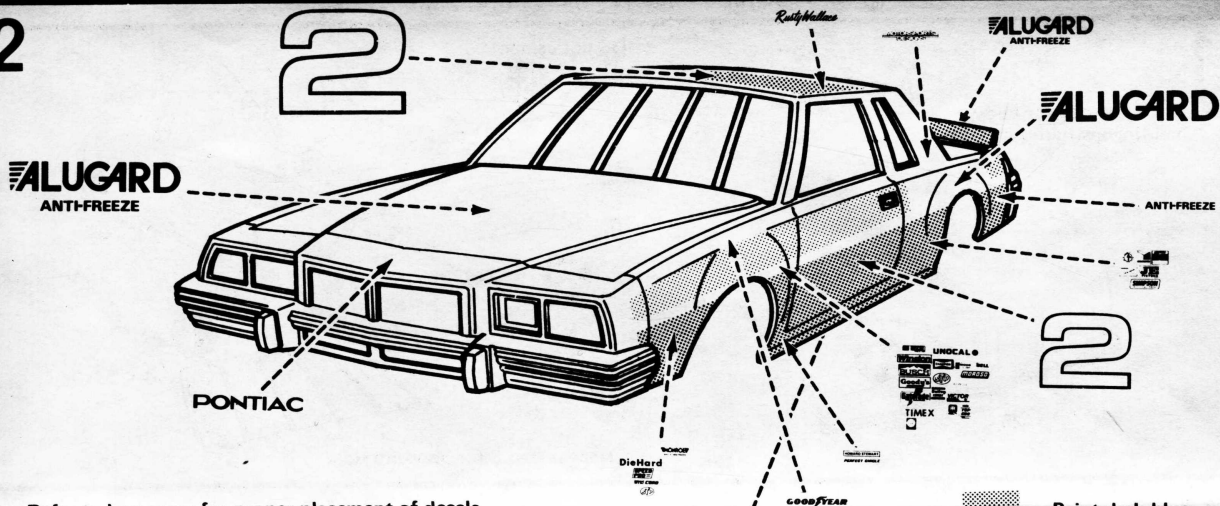

Note: Refer to box cover for proper placement of decals.  
 Repeat decal placement on opposite side where applicable.

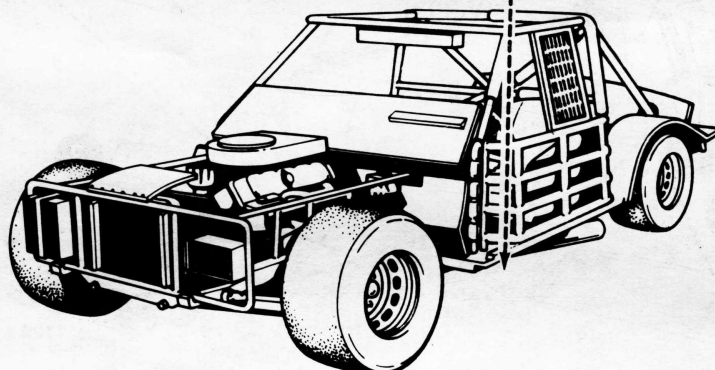

LICENSED UNDER AUTHORITY OF PATRUM MOTOR RACING PROPERTIES