



# 1:48 Westland Sea King HC.4

A11008 SCALE MODEL CONSTRUCTION KIT | Rotor Diameter: 397mm Length: 460mm | Four Decal Schemes Included | Two Build Options

EN

Well-suited for amphibious warfare and the tactical insertion of ground troops, the 'Commando' was an important variant of the Sea King. It was initially proposed as a tactical transport for the Egyptian Air Force for which the amphibious capability of earlier Sea Kings was not required and so the side floats were deleted. With folding rotors and tail, the Commando entered service with the Royal Navy as the Sea King HC.4. It would eventually be provided with radar-warning and infrared jamming devices, and could also deploy M130/M147 flares as countermeasures. Besides troops, it could also be fitted to carry underslung loads of up to 2.5 tonnes. Increased range and a 28-troop capacity made it ideal as an amphibious transport aircraft, and the HC.4 would see operational service in the Falklands, Balkans, Gulf, Lebanon and Afghanistan conflicts. It was often deployed in order to evacuate wounded personnel and refugees, as well as preparing for and supporting ground advances.

FR

Idéal pour la guerre amphibie et pour l'insertion tactique de troupes au sol, le Commando était une importante variante du Sea King. Il fut proposé au début comme transport tactique pour l'armée de l'air égyptienne qui n'avait pas besoin de la capacité amphibie des premiers Sea King et donc les flotteurs latéraux furent supprimés. Doté de rotors et queue repliables, le Commando dénommé Sea King HC.4 entra en service au sein de la Royal Navy. Il sera équipé d'avertisseur de radars et de brouilleur infrarouge tout en étant capable de lancer des leumes M130/M147 comme des contre-mesures. En plus des troupes, il pouvait être aménagé pour le transport de charges sous coisse jusqu'à 2,5 tonnes. Idéal comme appareil de transport amphibie avec son rayon d'action accru et sa capacité de transporter 28 troupes, le HC.4 fut en service opérationnel au cours des conflits aux Malouines, aux Balkans, au Golfe, au Liban et en Afghanistan. Il fut souvent utilisé pour évacuer les blessés et les réfugiés ainsi que pour la préparation et l'appui des attaques sur sol.

DE

Der für die amphibische Kriegsführung und die taktische Anlandung von Bodentruppen gut geeignete 'Commando' war eine wichtige Variante des Sea King. Ursprünglich sollte er als taktisches Transportmittel der Ägyptischen Luftwaffe dienen: weil sie die amphibischen Eigenschaften früherer Sea Kings jedoch nicht benötigte, wurden die seitlichen Schwimmkörper weggelassen. Der mit Klapprotoren und -leitwerk ausgerüstete Commando wurde bei der Royal Navy als Sea King HC.4 in Dienst gestellt. Später wurde er mit Radarwarngeräten und Infrarotstörgeräten ausgerüstet und konnte auch M130/M147 Störkörper als Gegenmaßnahme einsetzen. Entsprechend ausgerüstet konnte er neben Truppen auch bis zu 2,5 Tonnen schwere untergehängte Lasten mitführen. Mit seiner größeren Reichweite und Platz für 28 Soldaten ist der HC.4 ein ideales amphibisches Transportflugzeug und wurde im Falklands-, Balkan-, Golf-, Libanon- und Afghanistan-Konflikt eingesetzt. Oft evakuierte er verwundete Militärangehörige und Flüchtlinge, hinzu kam die Vorbereitung und Unterstützung des Bodenvormarsches.

ES

Bien adaptado para la guerra anfibia y para la introducción táctica de tropas de tierra, el 'Commando' fue una importante variante del Sea King. En un principio se propuso como transporte táctico para la aviación egipcia. Al no precisar las capacidades anfibas de los anteriores, se eliminaron los flotadores laterales. Con hélices y cola plegables, el Commando entró en servicio en la Royal Navy como Sea King HC.4. Posteriormente se equiparía con radar y dispositivos de interferencia por infrarrojos, y también podía equipar balizas M130/M147 como sistemas defensivos. Además de tropa, podía adaptarse para transportar hasta 2,5 toneladas de carga colgante. Su mayor autonomía y capacidad para 28 hombres lo hacían ideal como avión para transporte anfibia, y el HC.4 entró en servicio activo en los conflictos de las Malvinas, los Balcanes, el Golfo, Líbano y Afganistán. Fue muy utilizado para evacuar personal y refugiados, así como para preparar y apoyar avances por tierra.

SV

'Commando', som passade väl för amfibiekrigföring och taktisk insättning av marktrupper, utgjorde en viktig variant av Sea King. Inledningsvis föreslogs att den skulle utgöra taktisk transport för det egyptiska flygvapnet. Man tog då bort sidoflotterierna från de tidigare Sea King-helikopterns amfibiekapacitet. Med fallbar rotor och stjärt inleddes Commando sin tjänstgöring i Royal Navy som Sea King HC.4. Den skulle så småningom förses med radarvarning och infraröd störändare, och kunde även utrustas med M130/M147-lysraketer som motvapen. Bortsett från trupper kunde den även transportera last på upp till 2,5 ton på undersidan. Den ökade räckvidden och en truppkapacitet på 28 innebar att helikopterna passade utmärkt för amfibietransport, och HC.4 användes därför i aktiv tjänst i konflikterna på Falklandsöarna, Balkan, Persiska viken, Libanon och Afghanistan. Den användes ofta för att evakuera sårade och flyktingar samt under förberedelser och genomförande av framryckningar på marken.

### Specification

Speed: 129 mph (208km/h)  
Range: 246 miles (396 km) at full troop capacity  
Rotor Diameter: 62 ft 0 in (18.9m)  
Length: 55 ft 10 in (22 m)  
Engines: 2x Rolls Royce Gnome Turboshifts

### Spécification:

Vitesse: 208 km/h  
Autonomie: 396 km appareil chargé de 28 soldats  
Diamètre du rotor: 18.9m  
Longueur: 22 m  
Moteurs: deux Rolls Royce Gnome Turboshift

### Spezifikation:

Geschwindigkeit: 208 km/Std.  
Reichweite: 396 km bei voller Truppenkapazität  
Rotordurchmesser: 18,9 m  
Länge: 22 m  
Triebwerke: 2 Rolls-Royce Gnome Wellenturbinen

### Especificación:

Velocidad: 208 km/h  
Autonomía: 396 km con plena capacidad de tropas  
Diámetro de las hélices: 18,9 m  
Longitud: 22 m  
Motores: 2 Rolls Royce Gnome de turbosje

### Spekifikation:

hastighet: 208 km/h  
Räckvidd: 396 km fullastad med trupper  
Rotordiameter: 18,9 m  
Längd: 22 m  
Motorer: Två Rolls Royce Gnome-turbinmotorer

Airfix would like to thank the following individuals/organisation for their assistance in the development of this model: Historic Helicopters, HeliOperations, Bournemouth Aviation Museum, HMS Sultan, Crispin Morton, Lee Howard, Chris Page MBE, South Yorkshire Aviation Museum, Aerospace Logistics Ltd and the Fleet Air Arm Officers Association.

**HORNBY  
HOBBIES**

### FOR BEST RESULTS:

Surfaces to be painted should be clean — before parts are removed from the sprue, wash in warm, soapy water, rinse and dry thoroughly. Stir paints thoroughly before use.

### PLEASE NOTE:

Some parts in the kit may not be required to build the model specified.

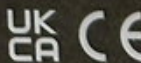

Manufactured by: Hornby Hobbies Ltd Westwood, Margate, Kent, CT9 4JX, UK +44(0)1843 233525 customerservices.uk@hornby.com

EU Authorised Representative: Hornby Italia SRL Viale dei Caduti, 52/A6, Castel Mella (BS), Italy, 25030 +39 0687501292 customerservices.it@hornby.com

**Note:** Before you start, choose which scheme layout option to build and drill the holes highlighted on page 3 to page 5.  
**Important :** Only drill the holes shown in red.

Bottom View

**A B C D HC.4**

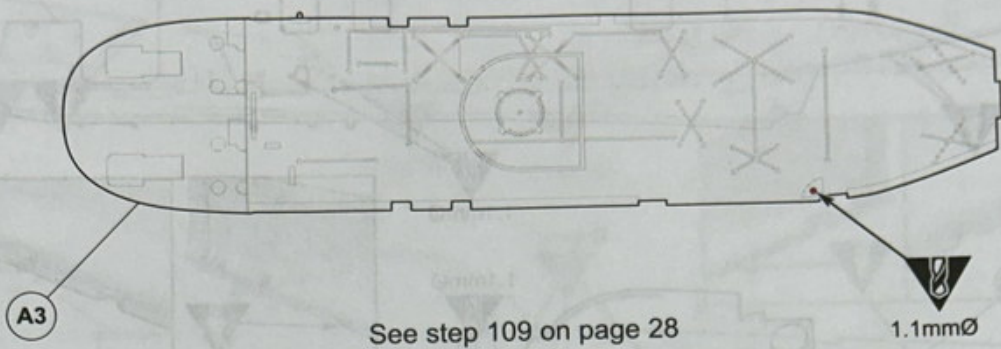

Top View

**A B C D HC.4**

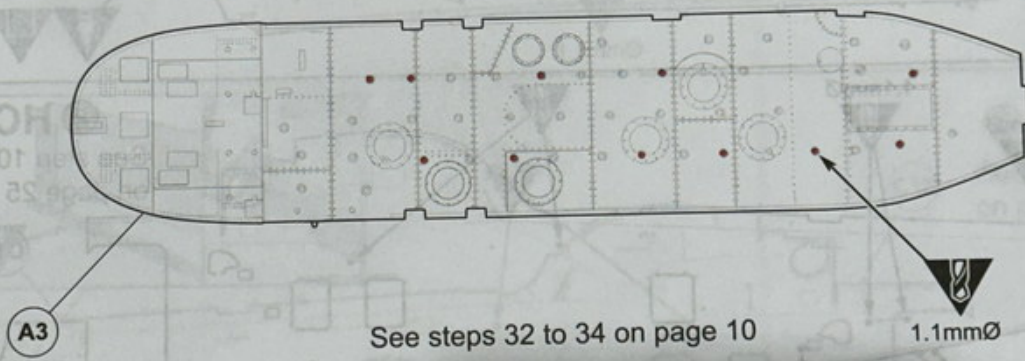

Top View

**D HC.4**

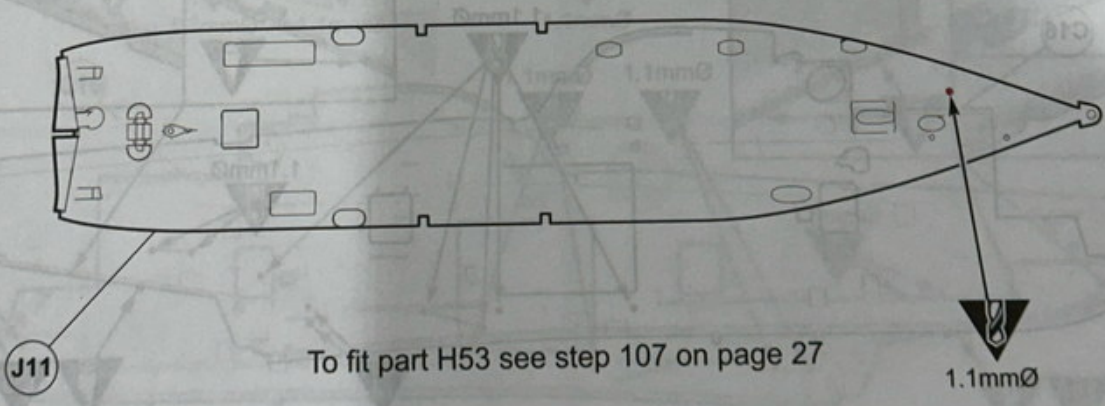

**A HC.4**

See step 104  
on page 24

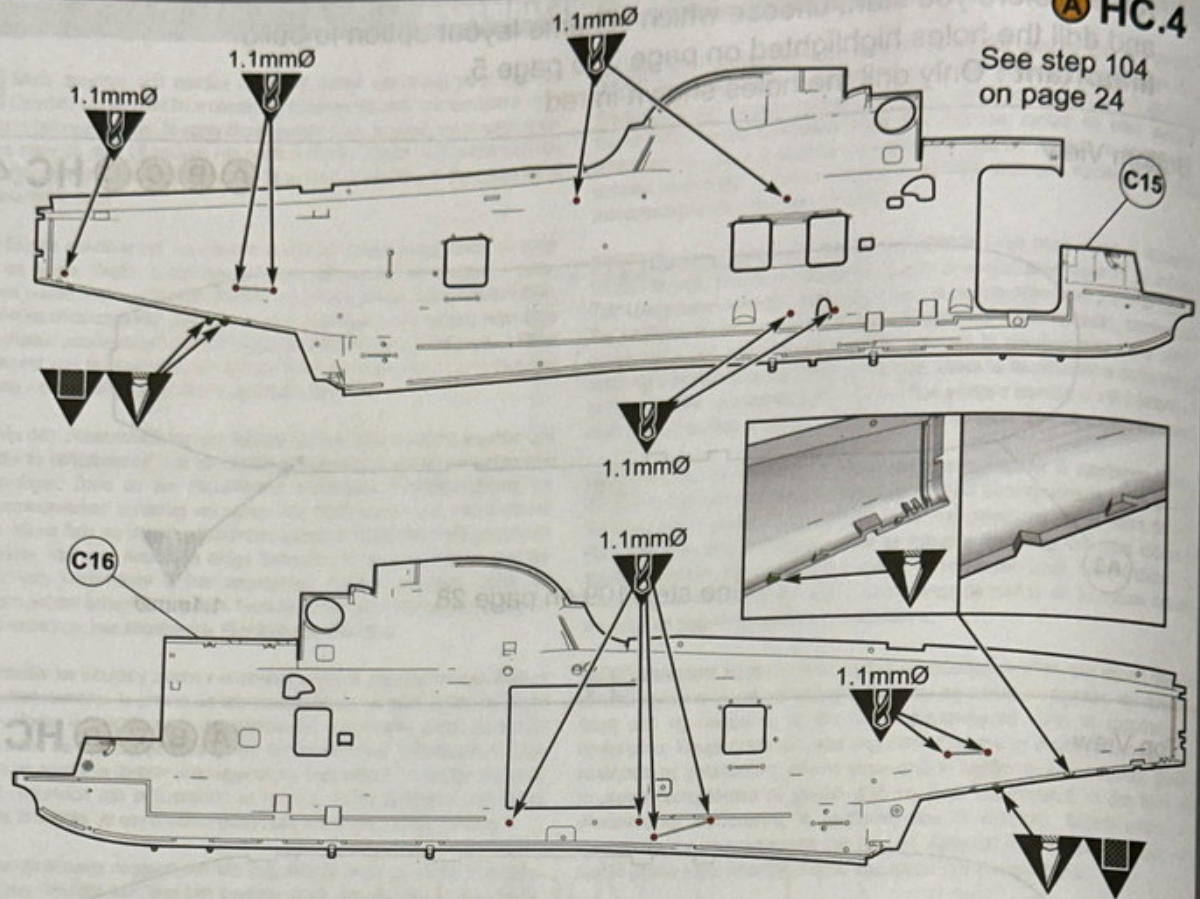

**B HC.4**

See step 105  
on page 25

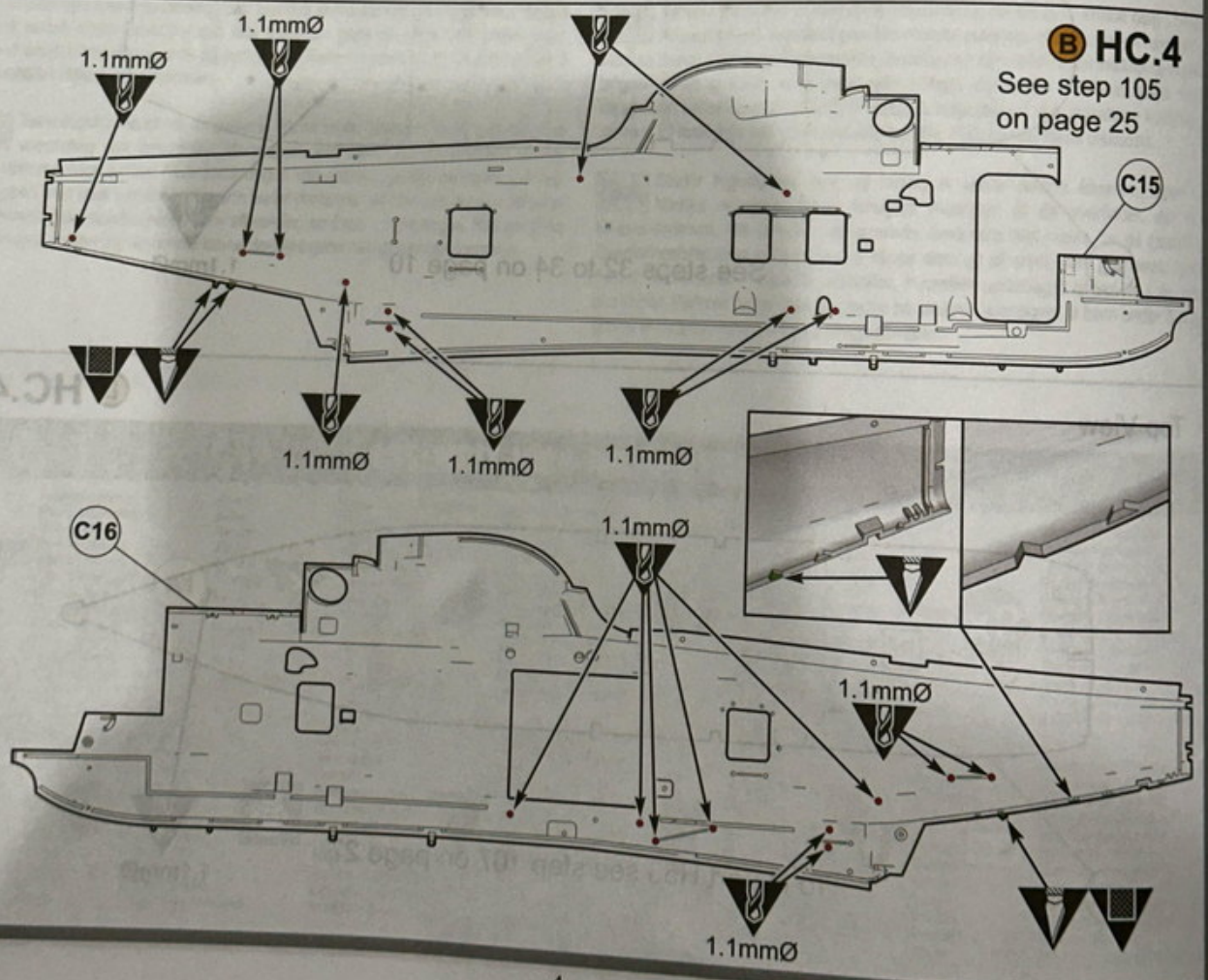

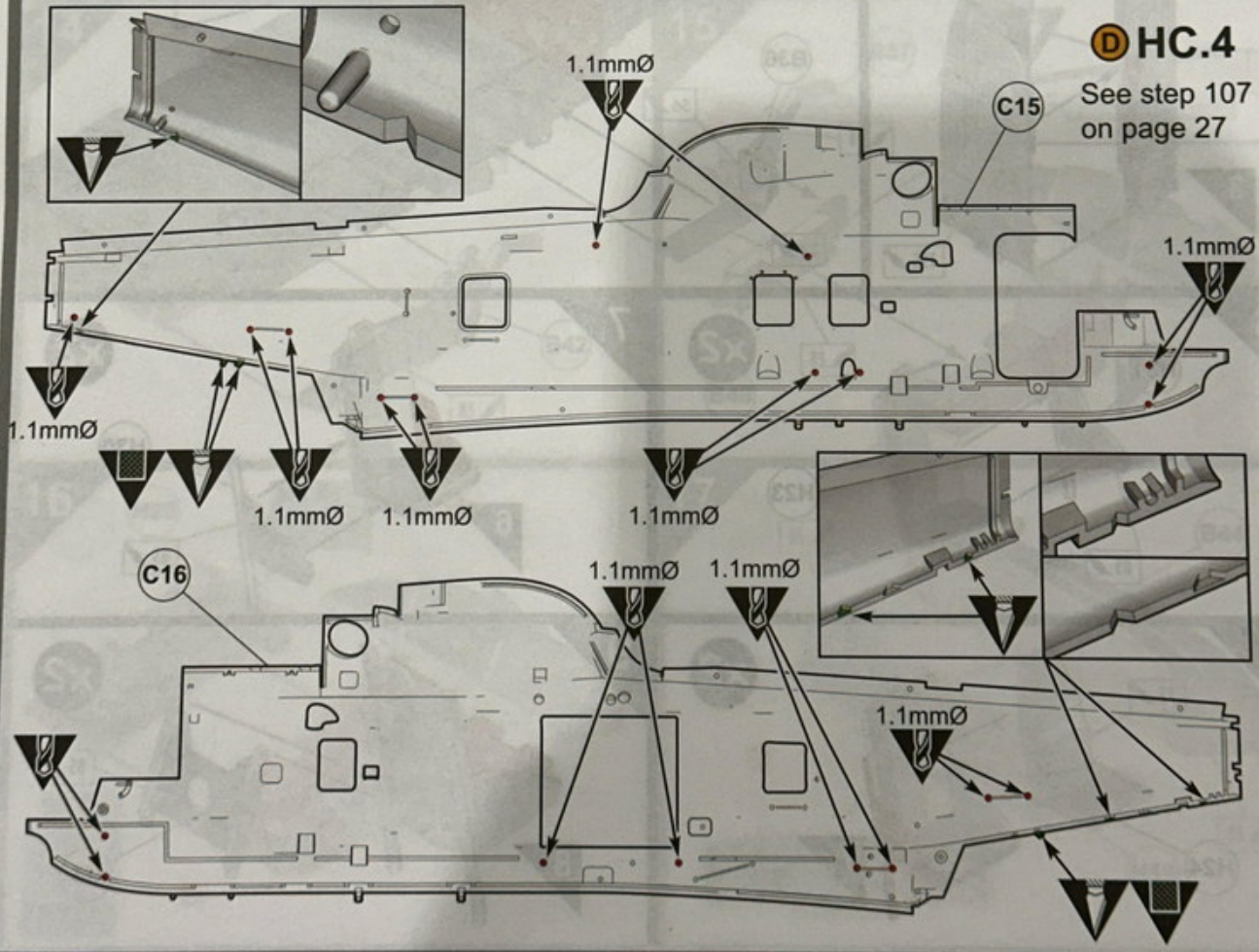
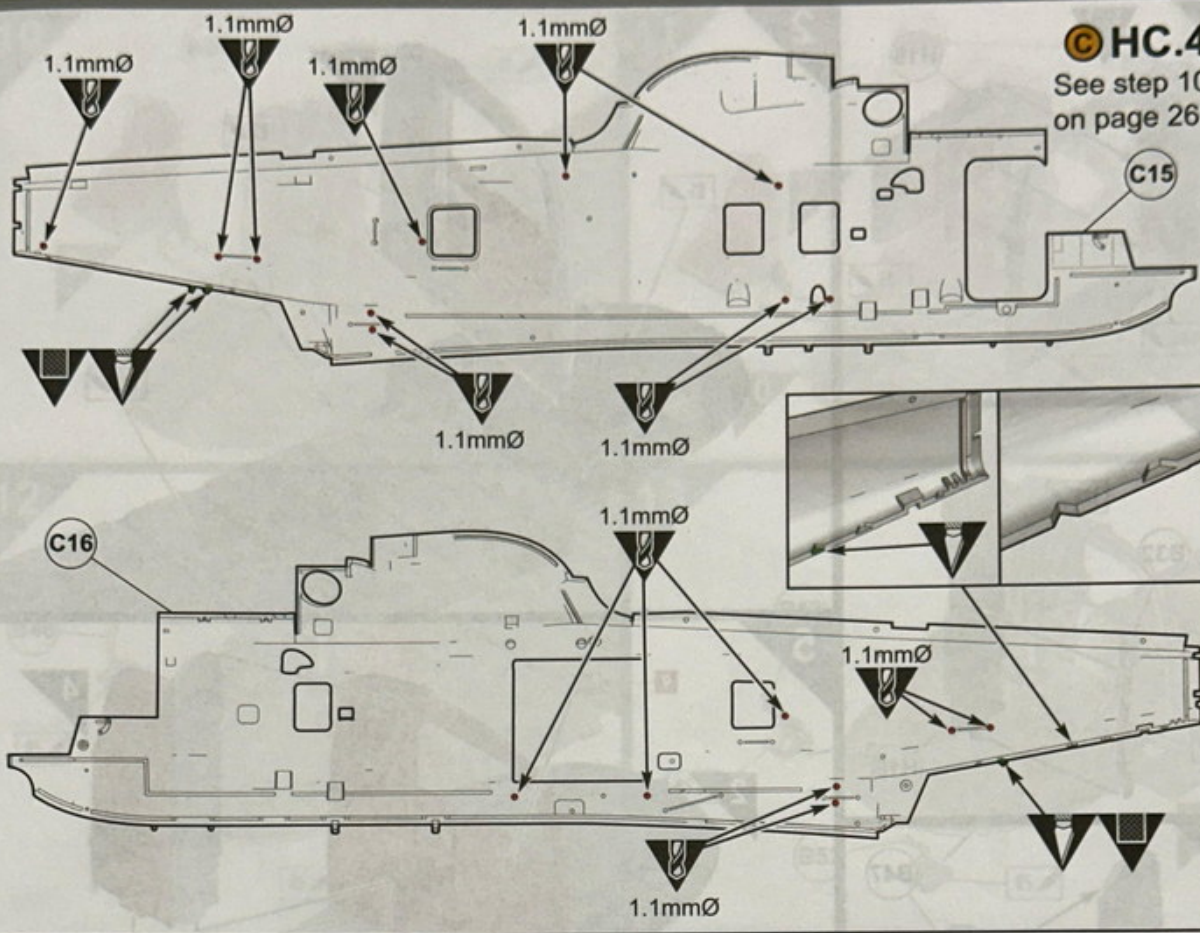

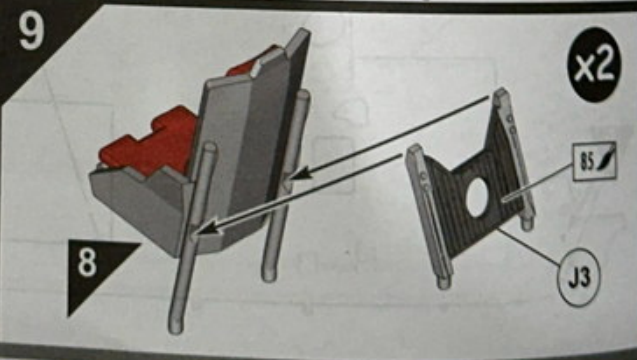
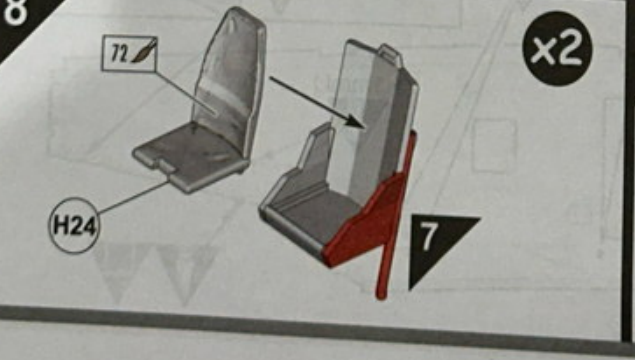
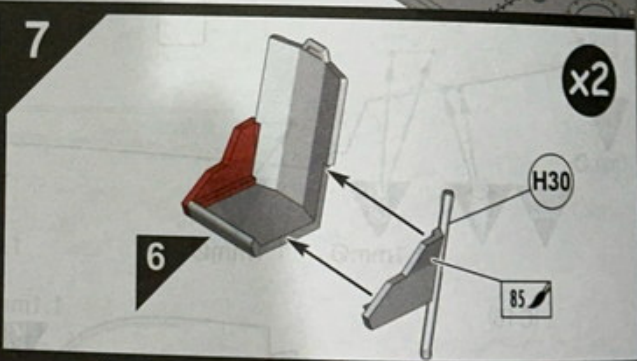
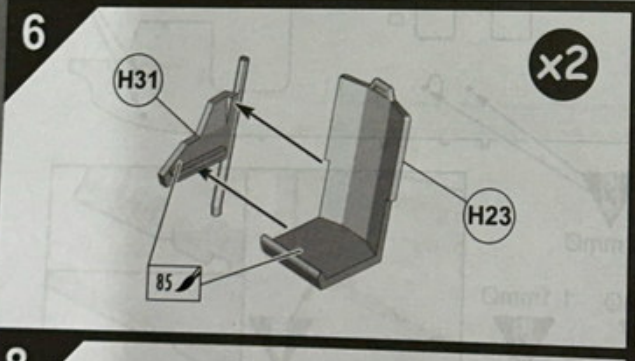
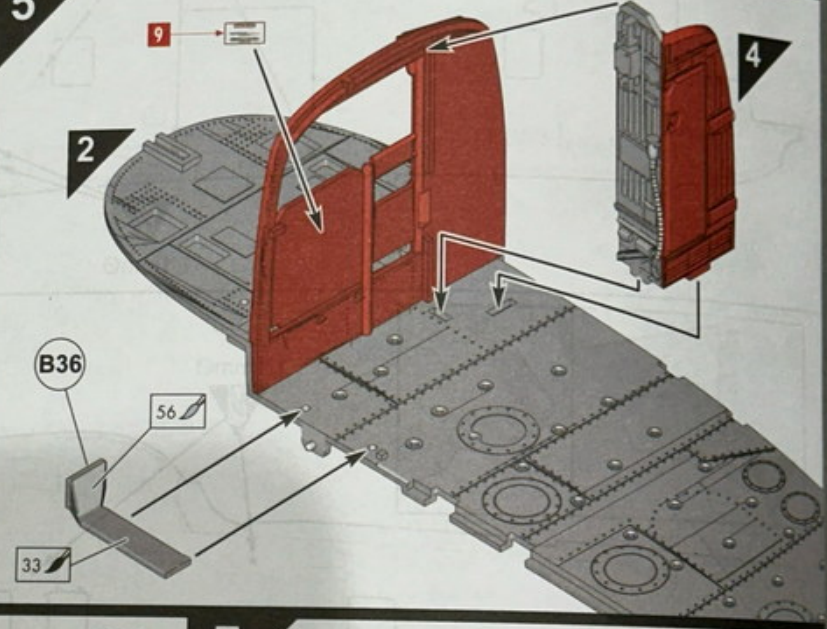
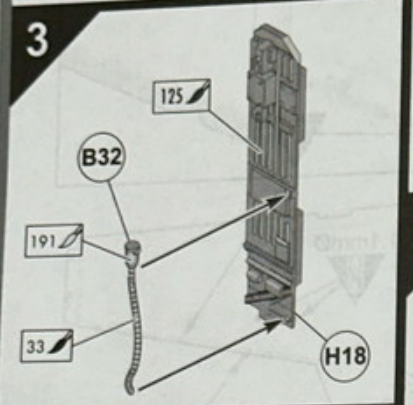
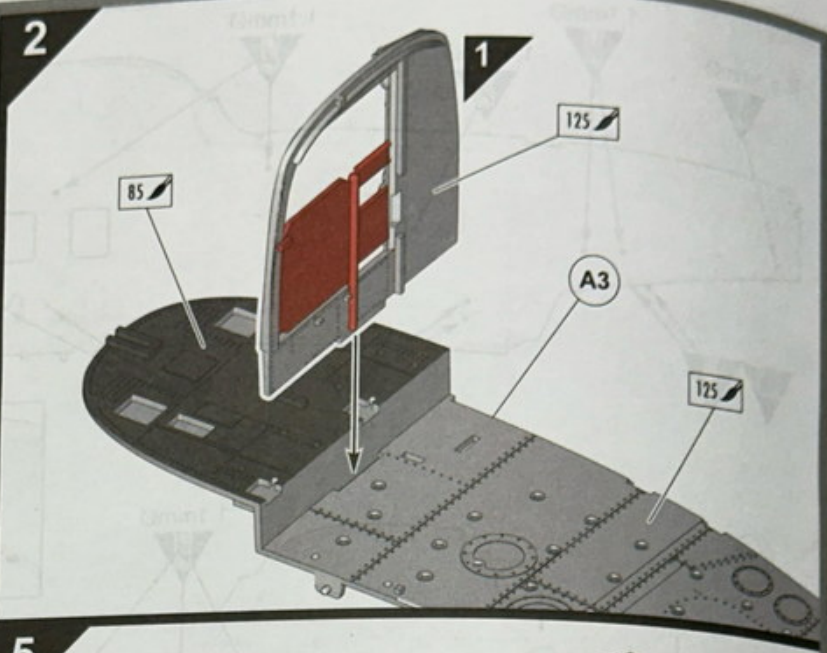
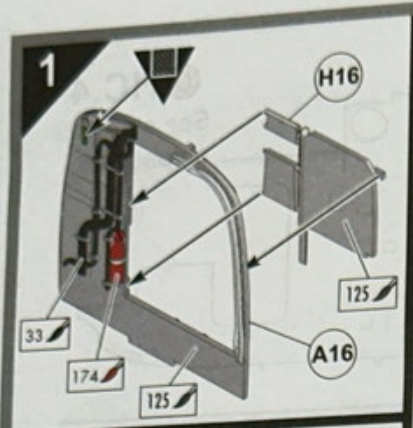

10

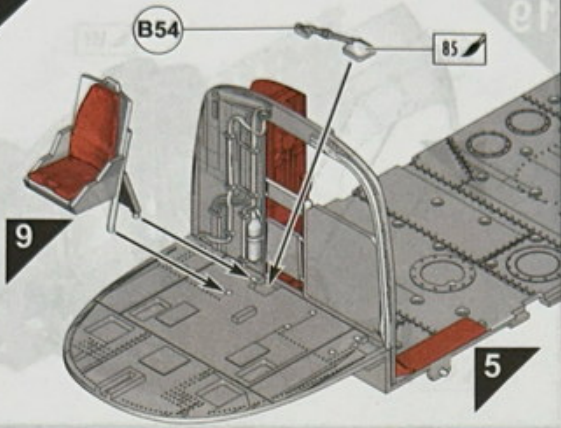

11

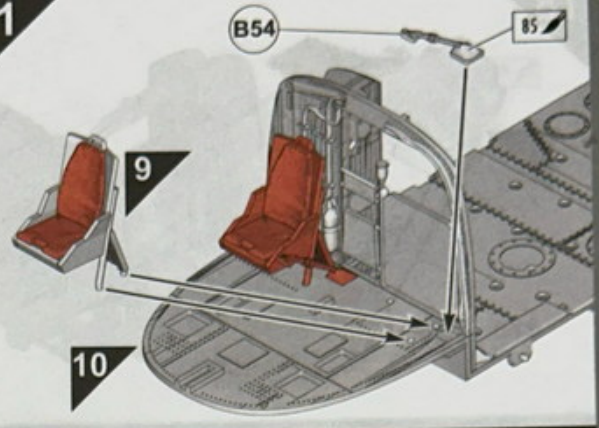

12

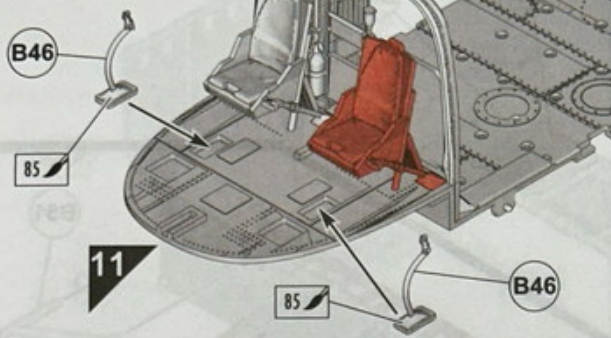

13

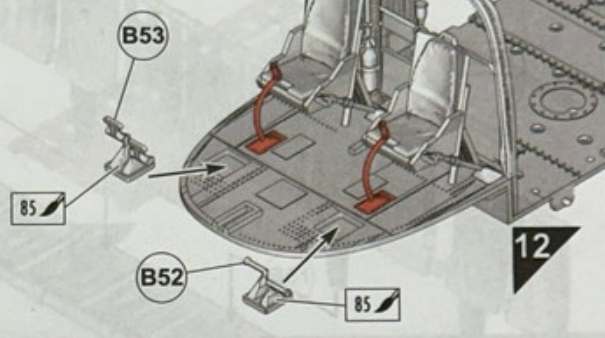

14

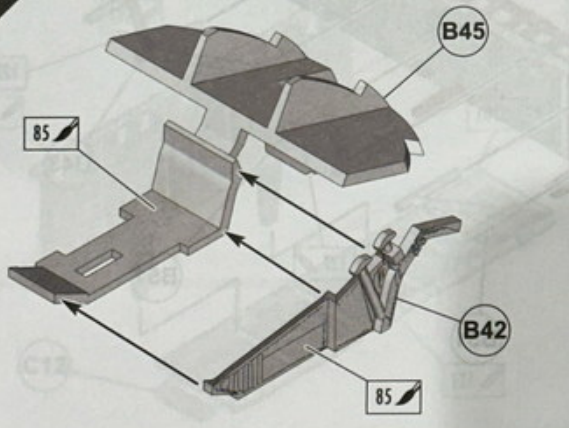

15

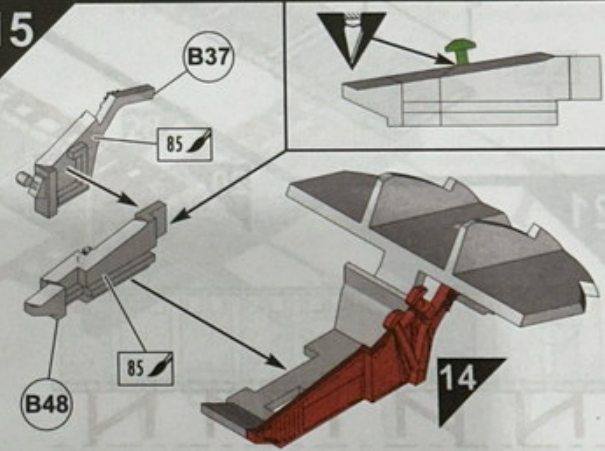

16

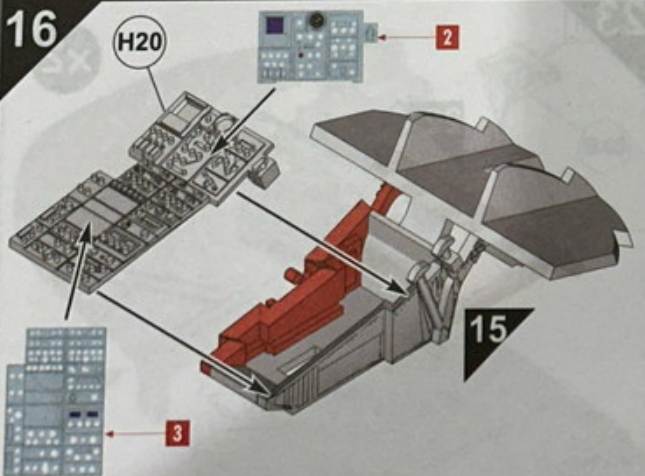

17

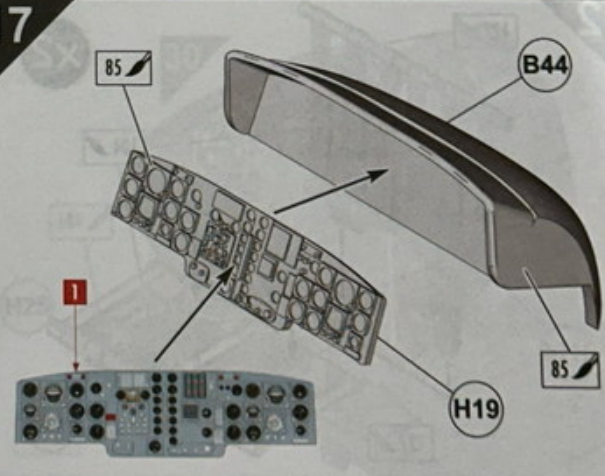

18

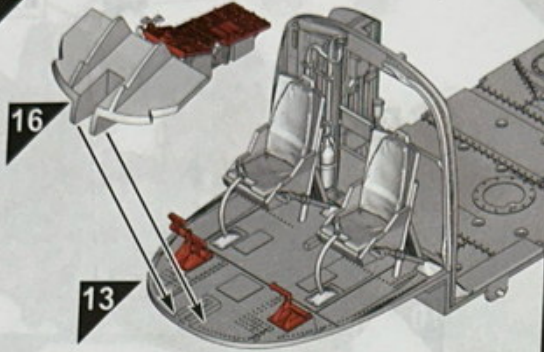

19

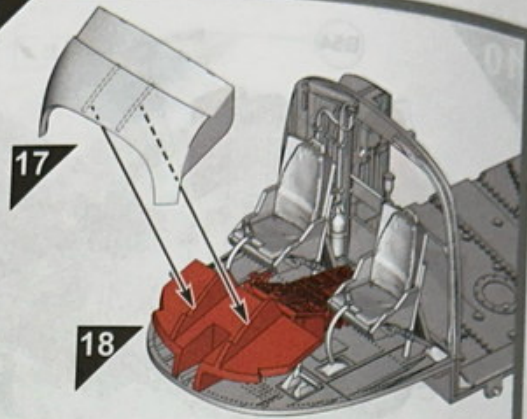

20

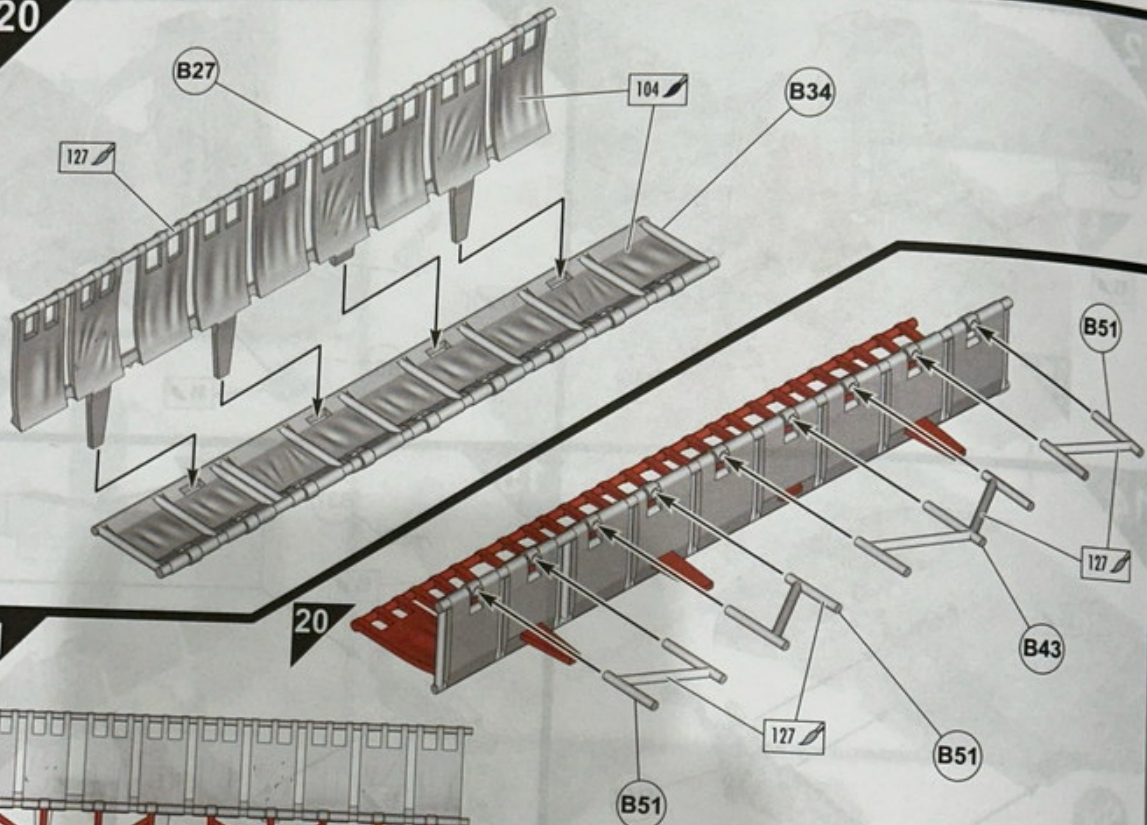

21

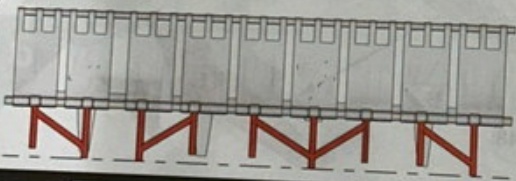

22

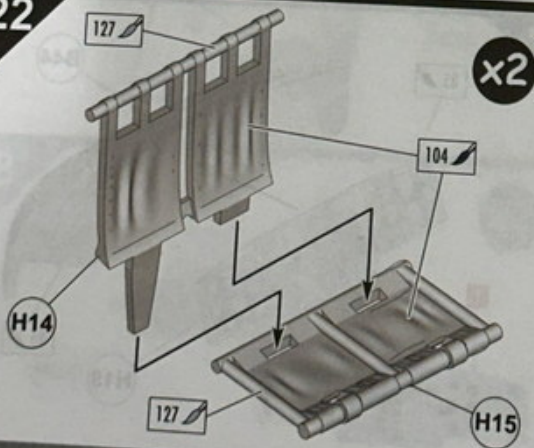

23

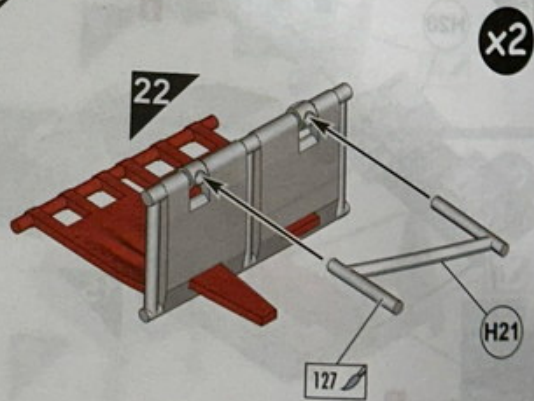

24

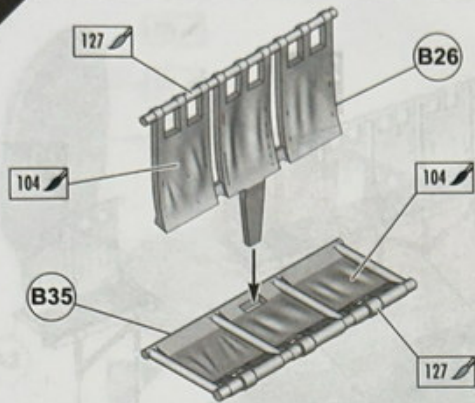

25

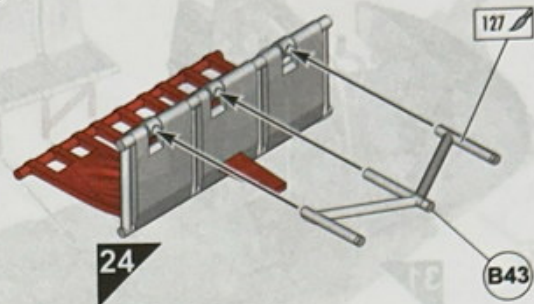

26

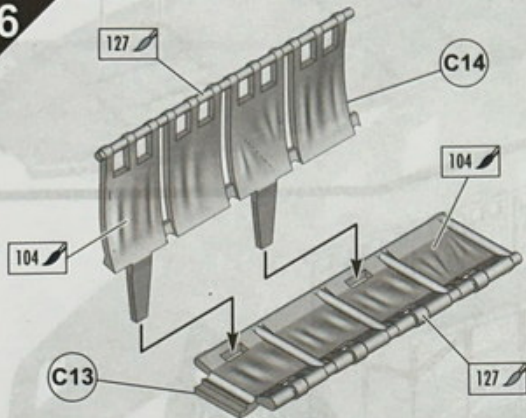

27

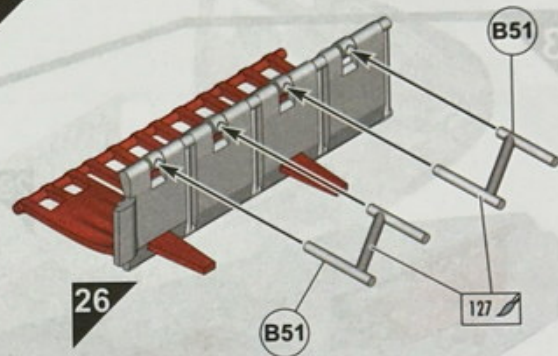

28

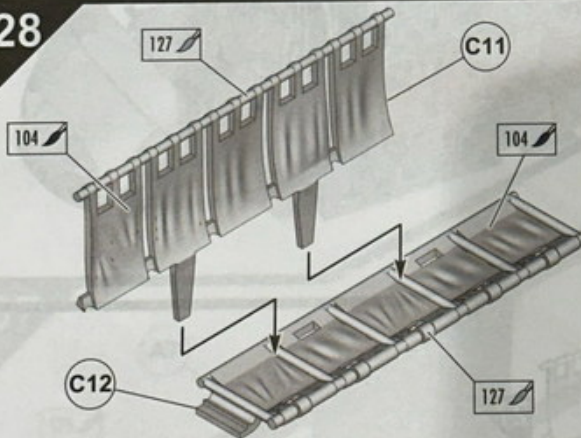

29

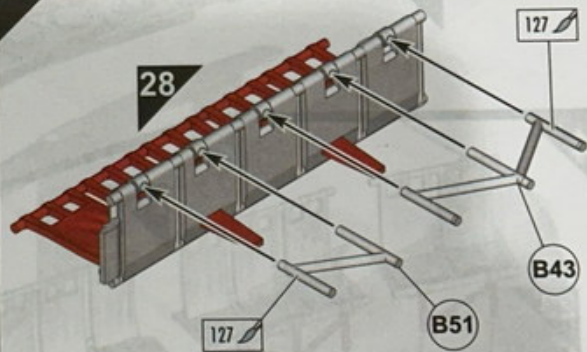

30

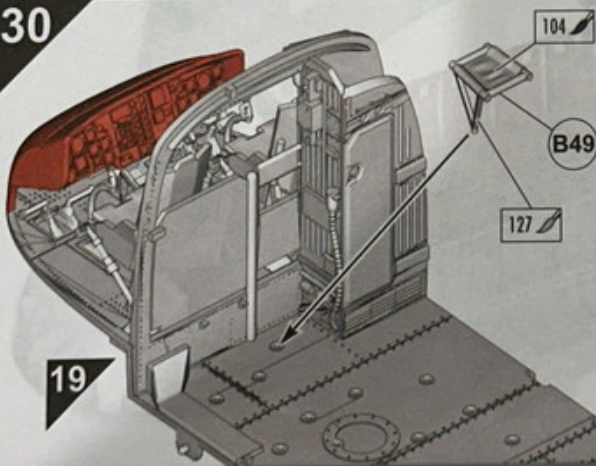

31

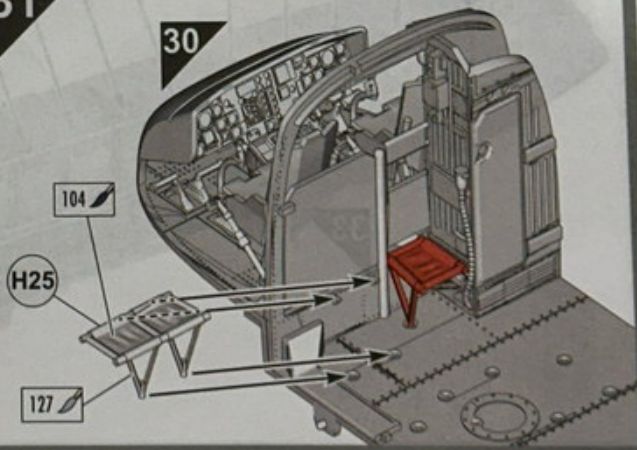



32

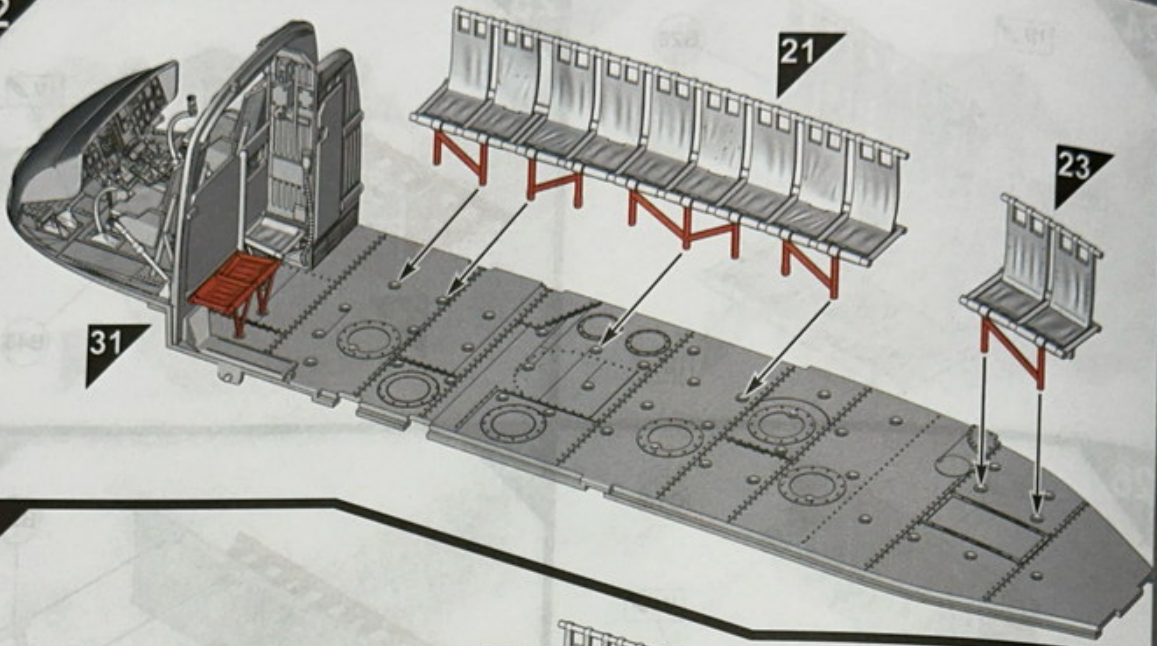

33

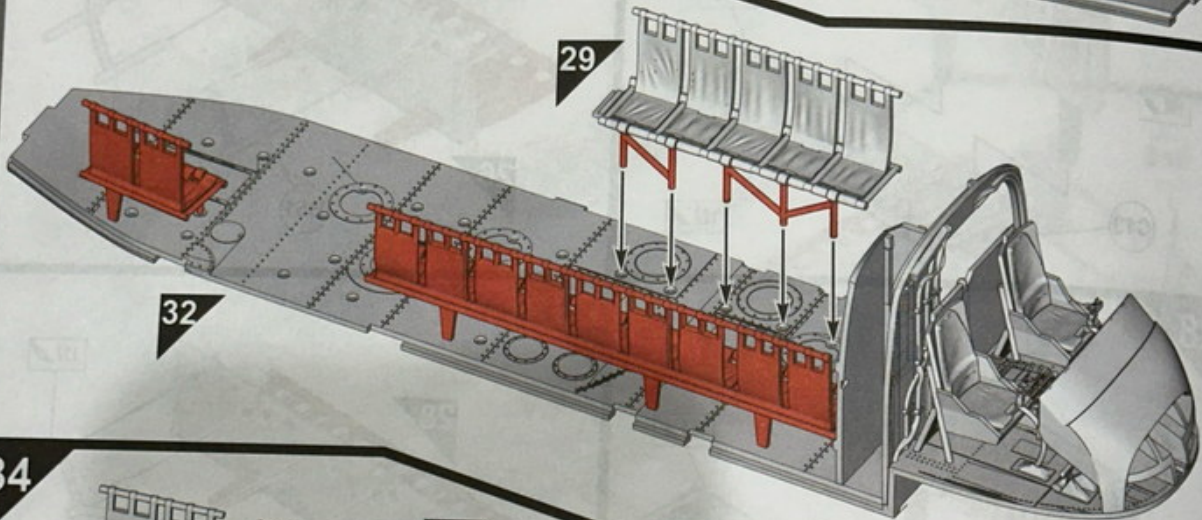

34

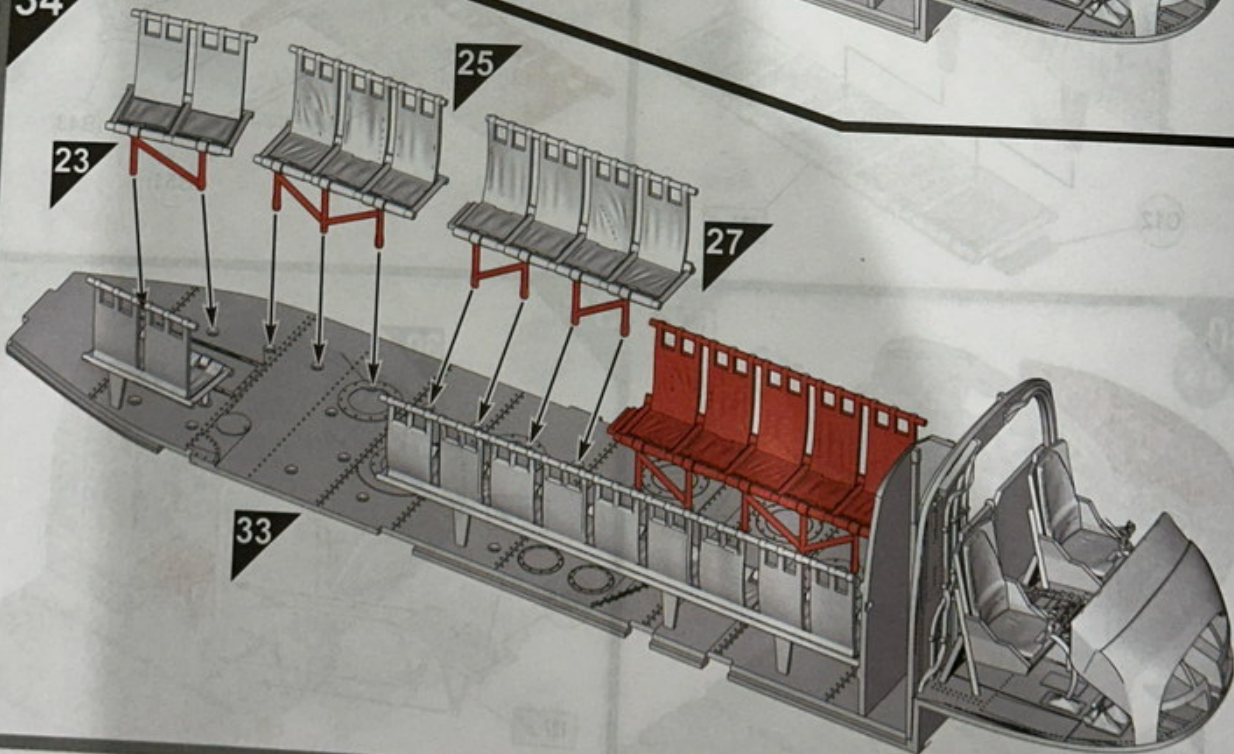

35

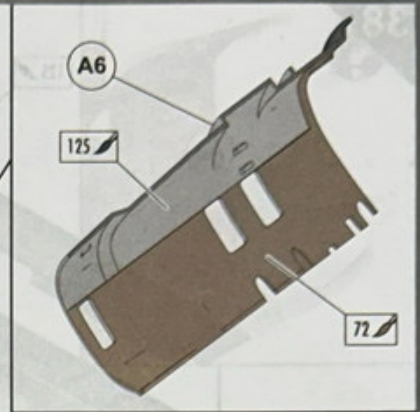
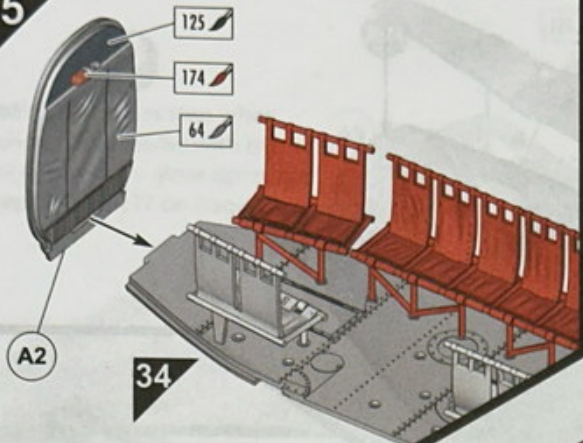

36

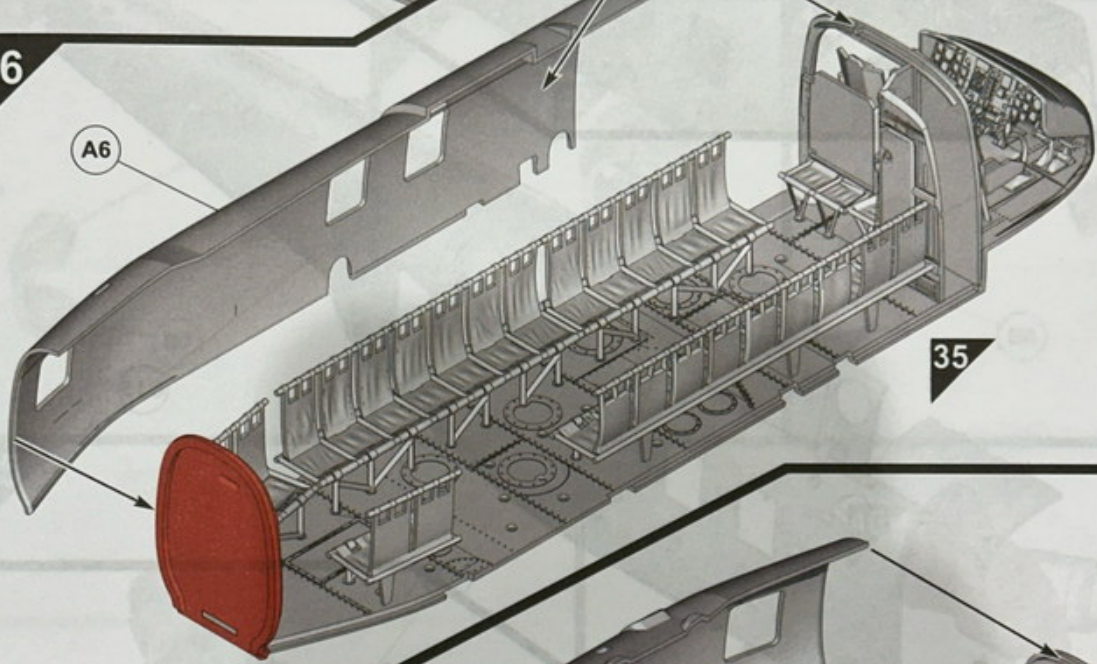

37

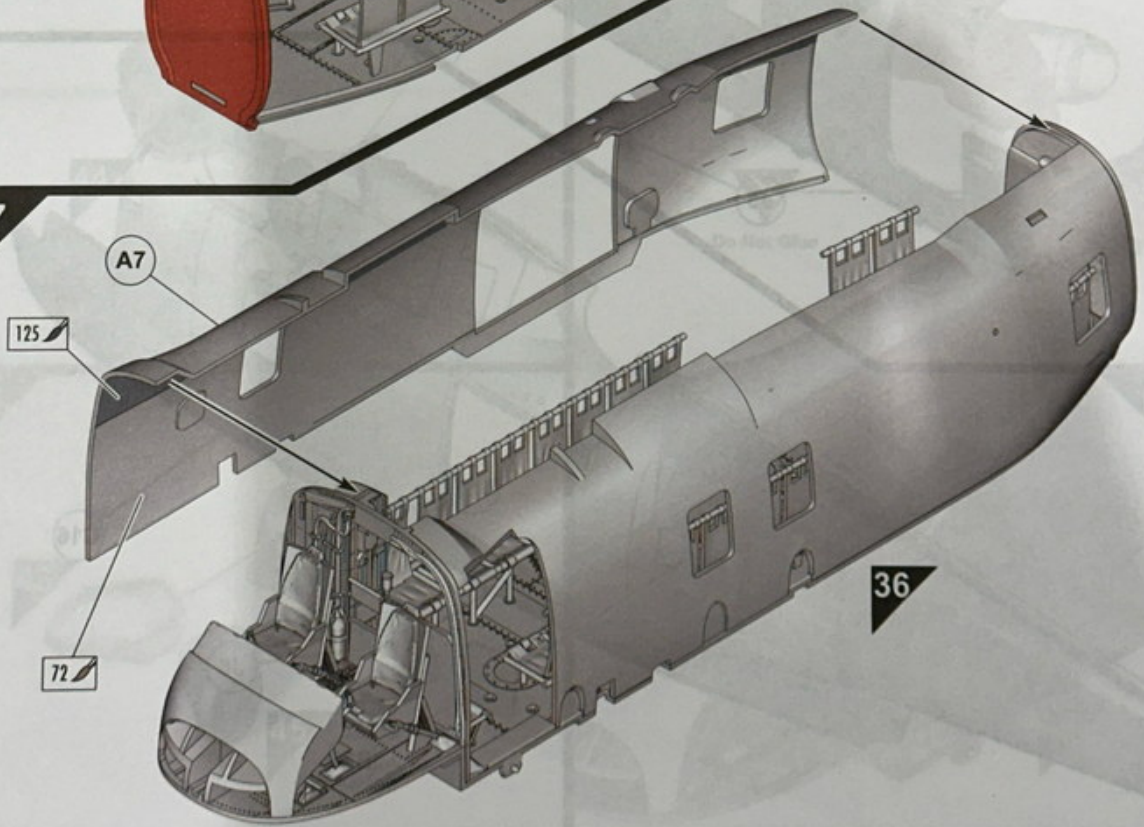

38

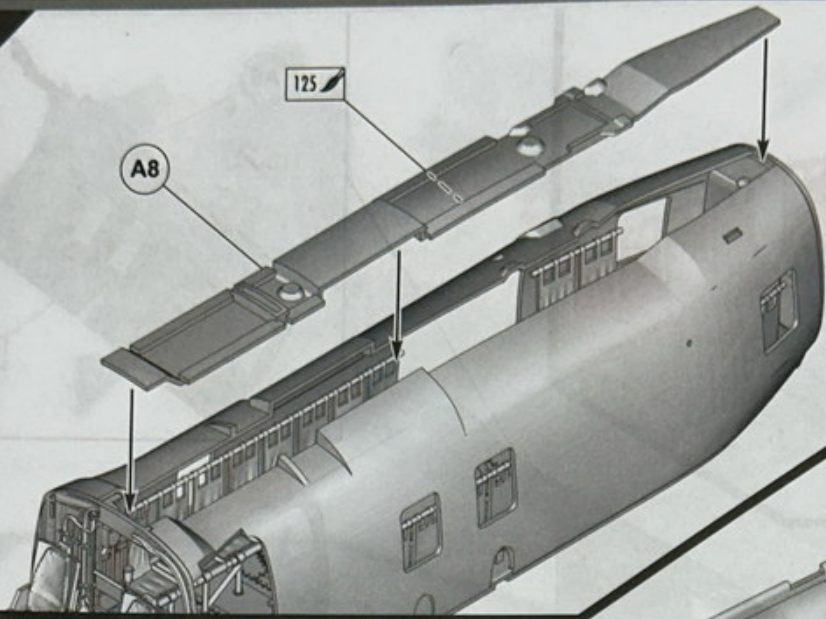

37

39

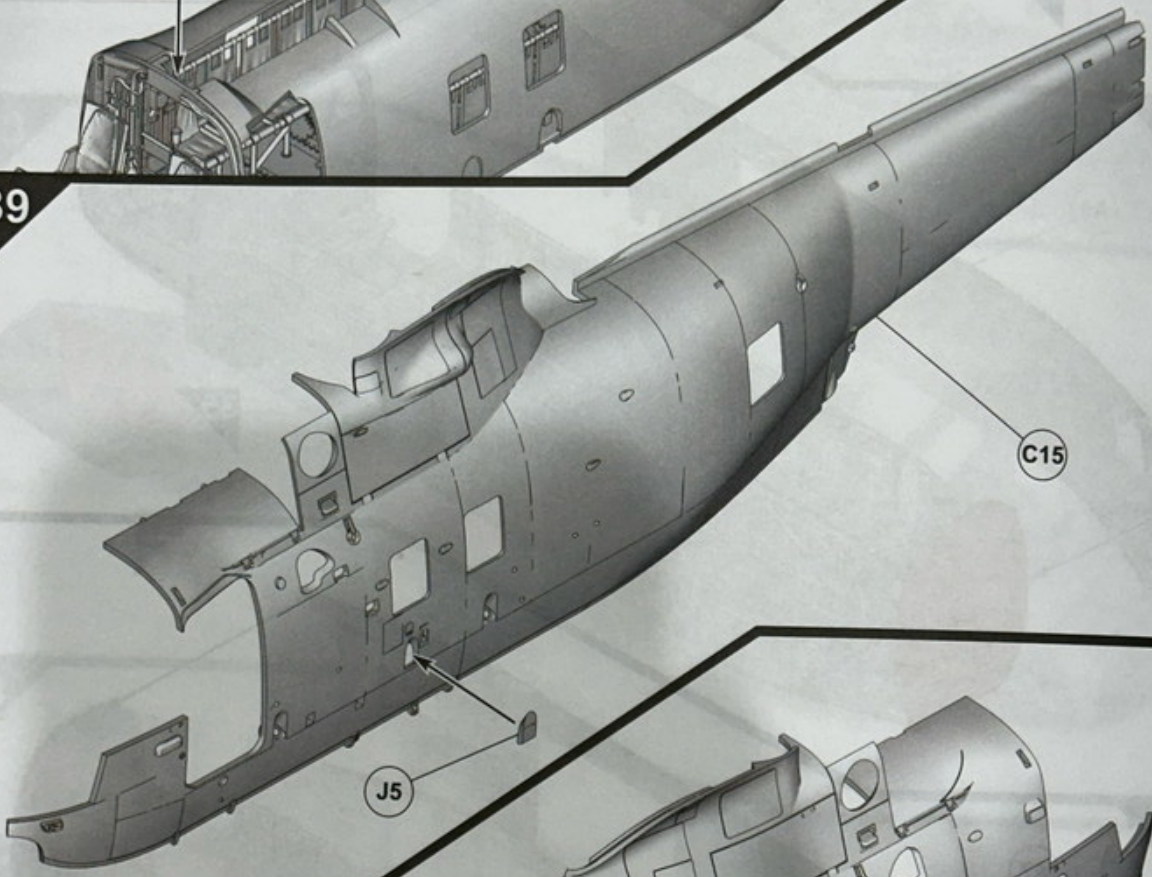

C15

40

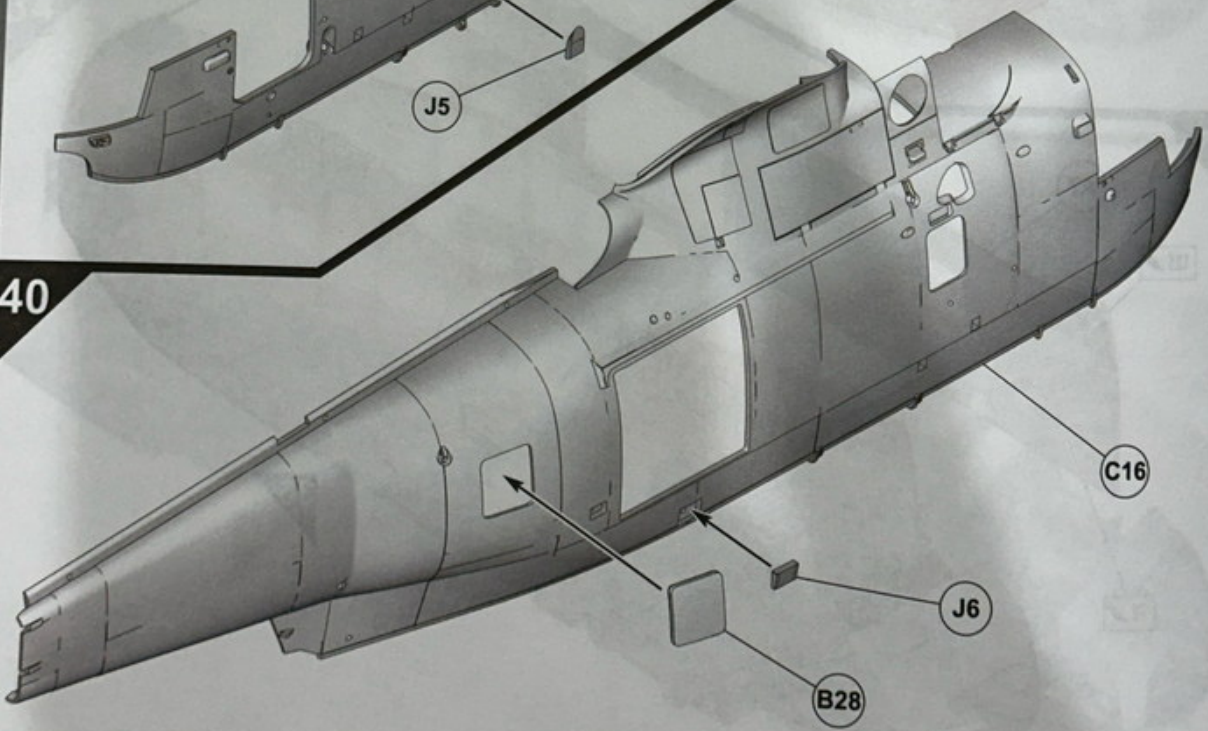

C16

J6

B28

41

Note: For building door close Steps 1

42

45

46

43

41



**Note:** Follow this step when building this model with the door closed. For door open, see Steps 115 to 117 on page 29.

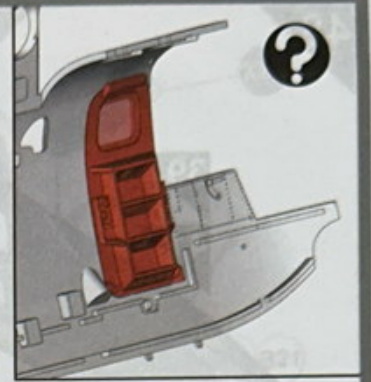
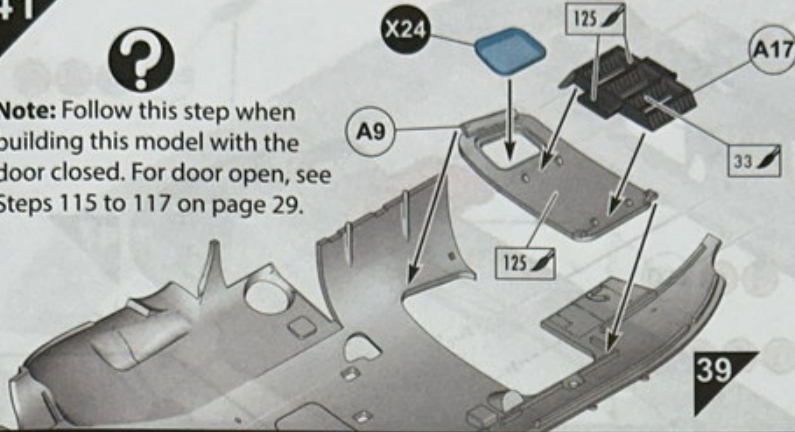

42

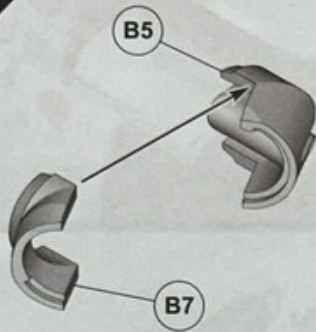

43

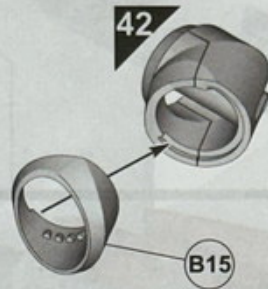

44

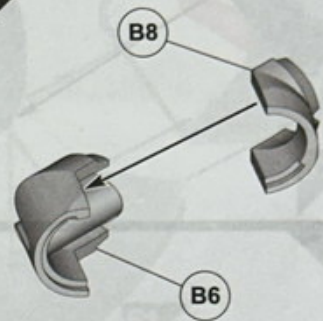

45

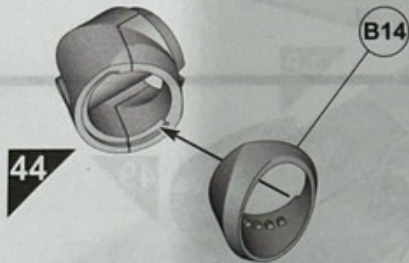

47

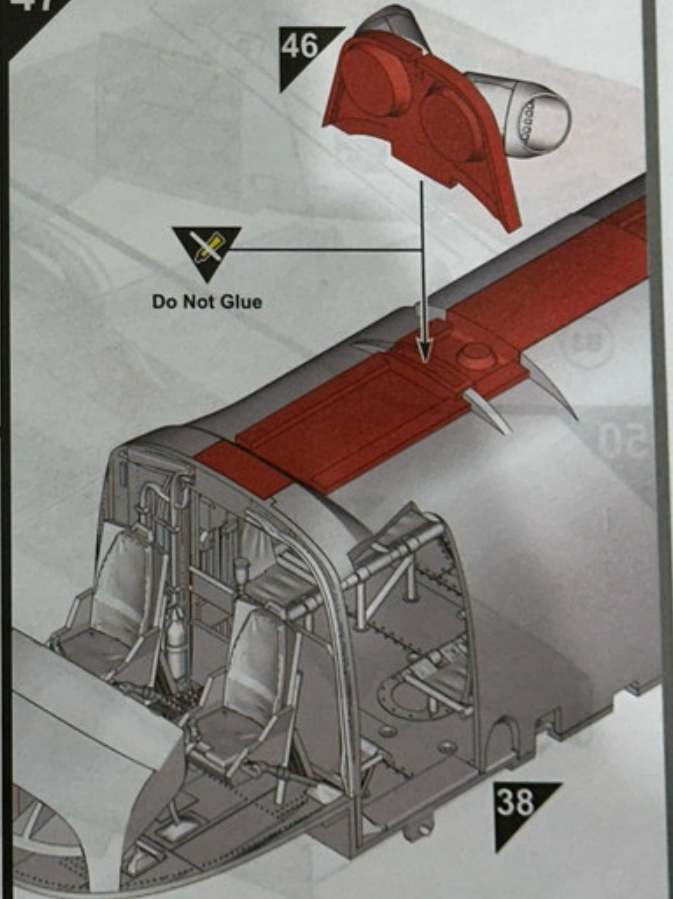

46

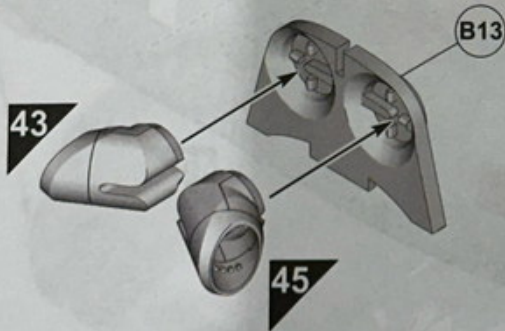

48

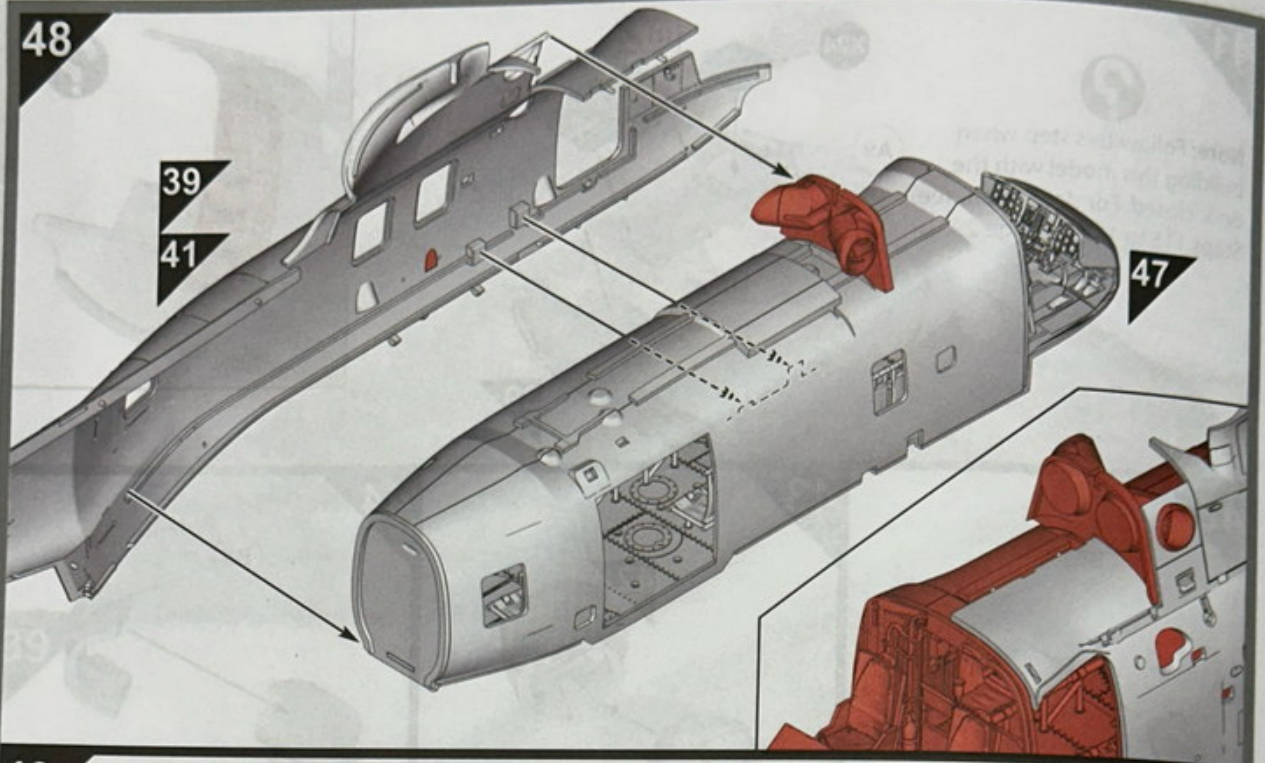

49

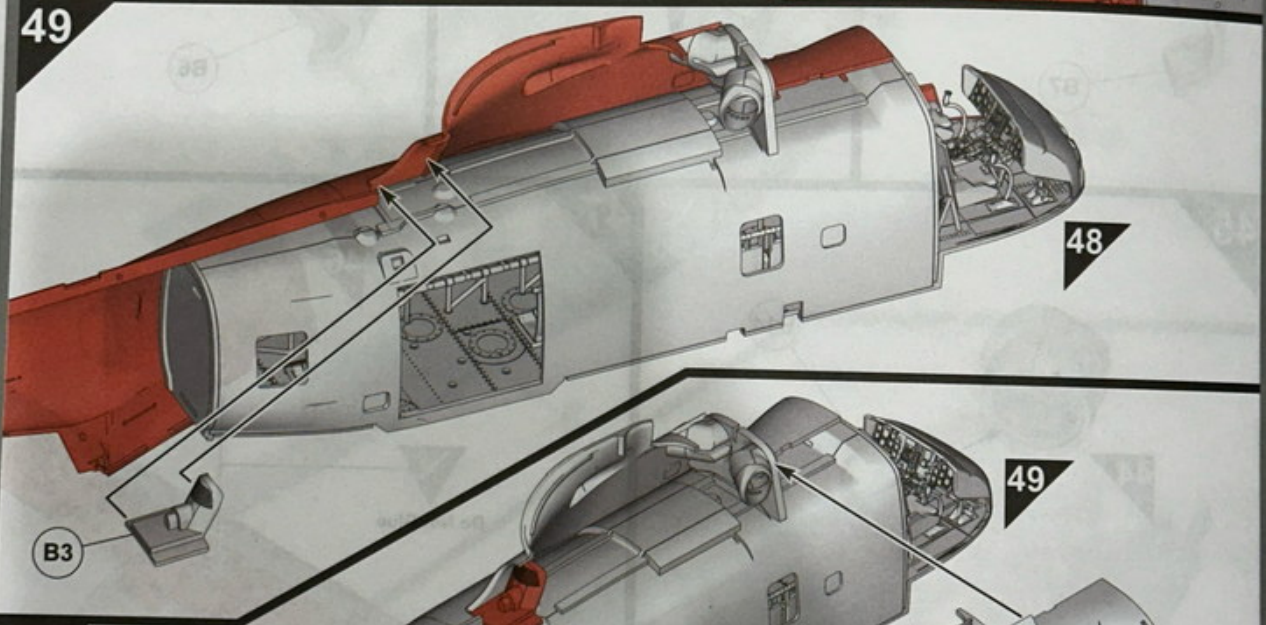

50

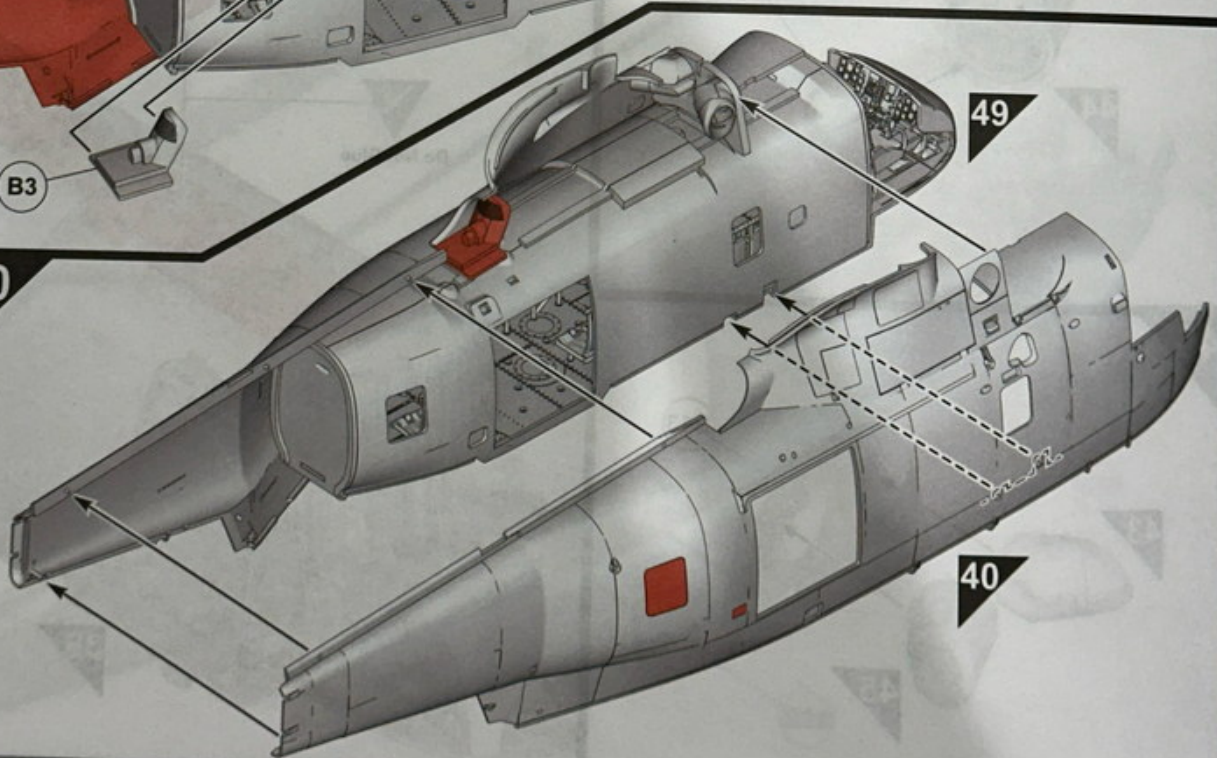

51

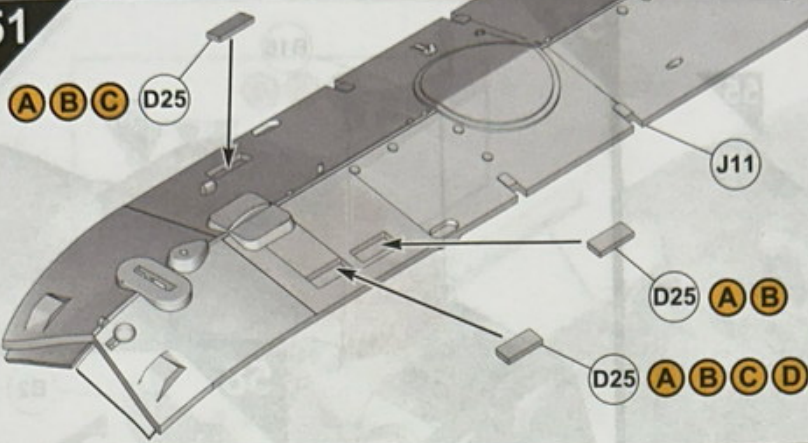

52

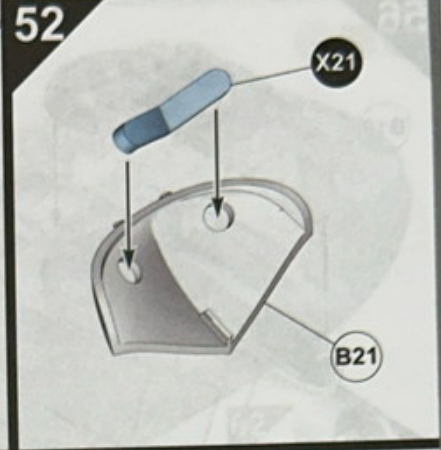

53

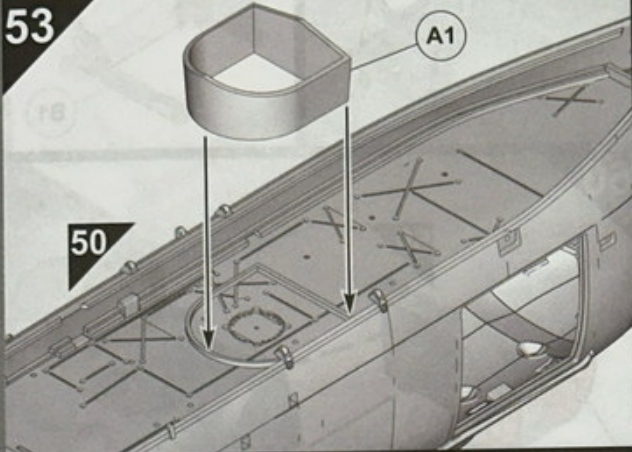

54

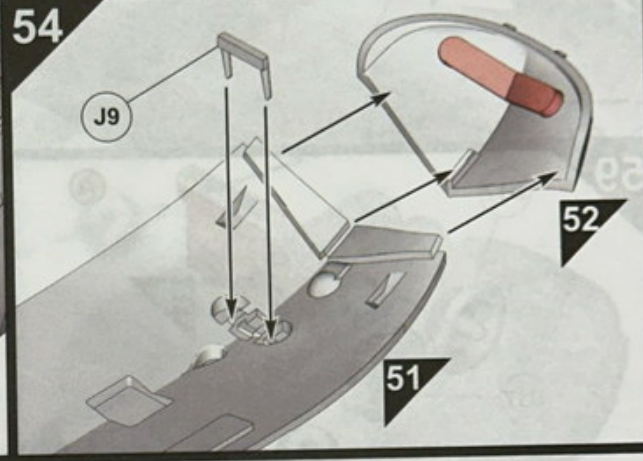

55

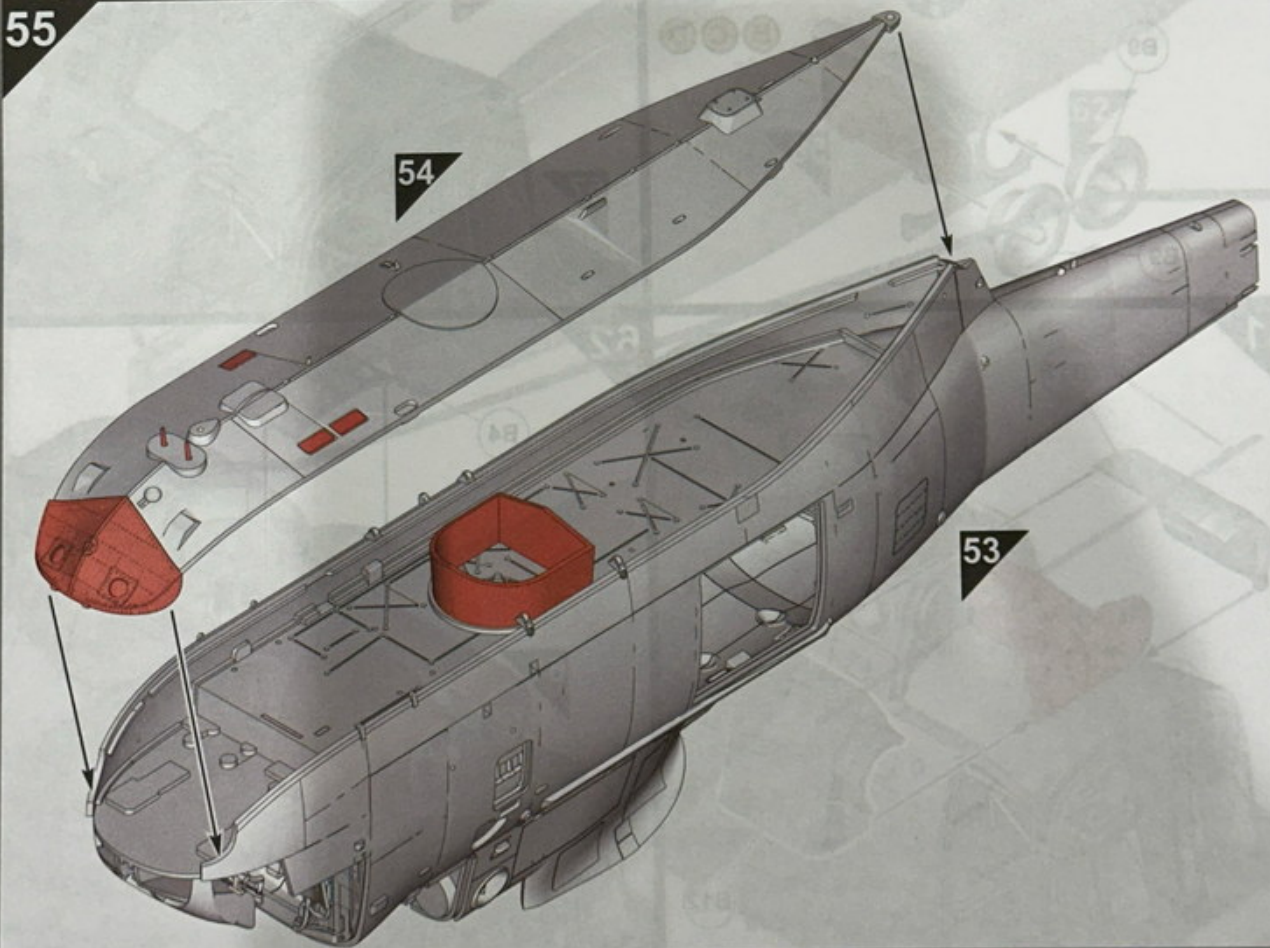

56

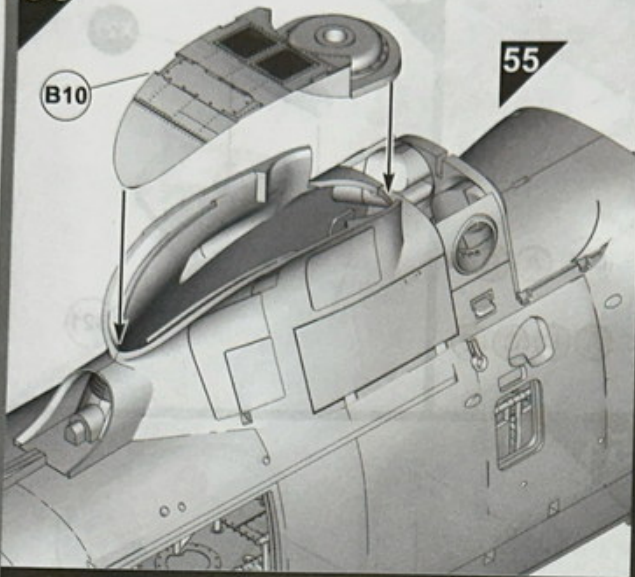

57

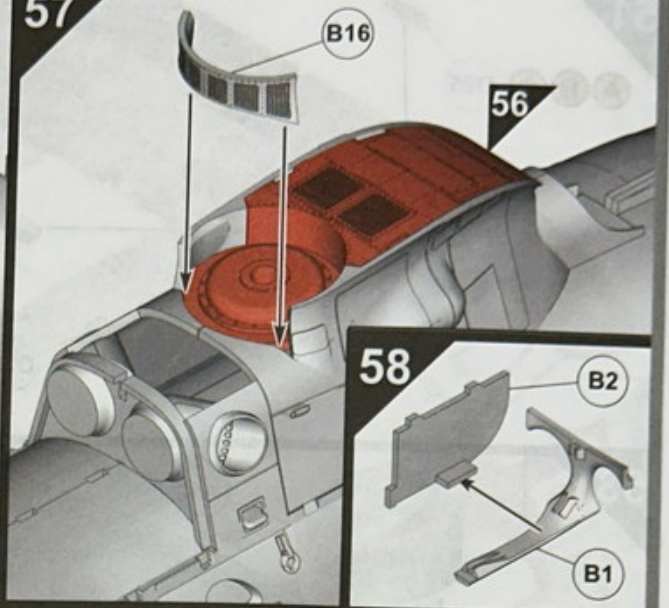

59



60

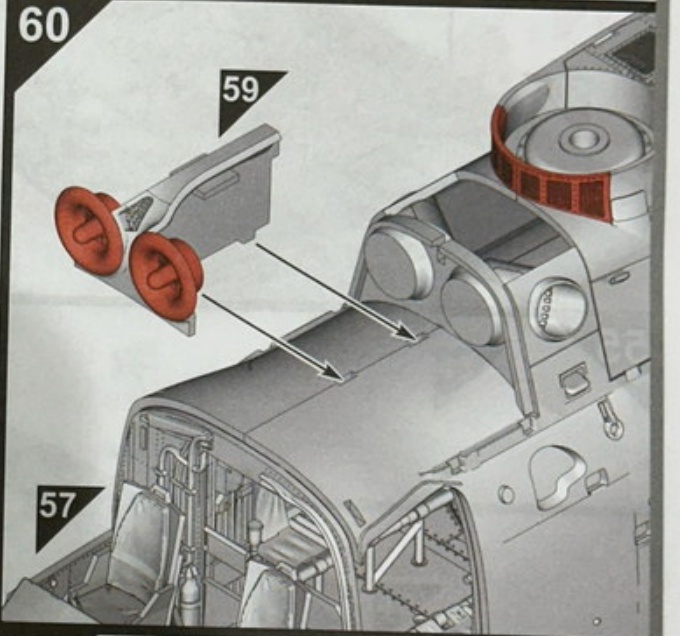

61

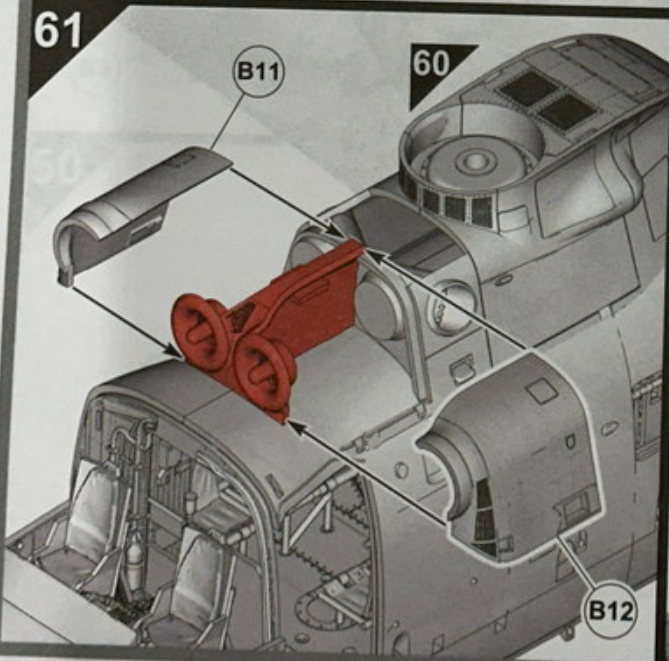

62

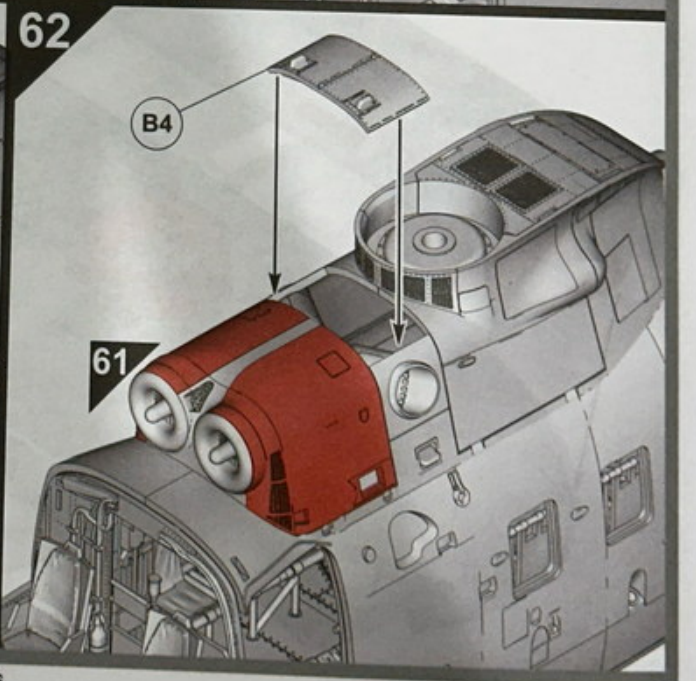

63

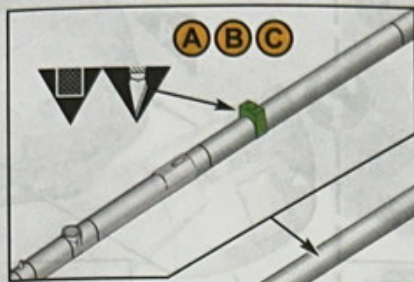

A B C

H27

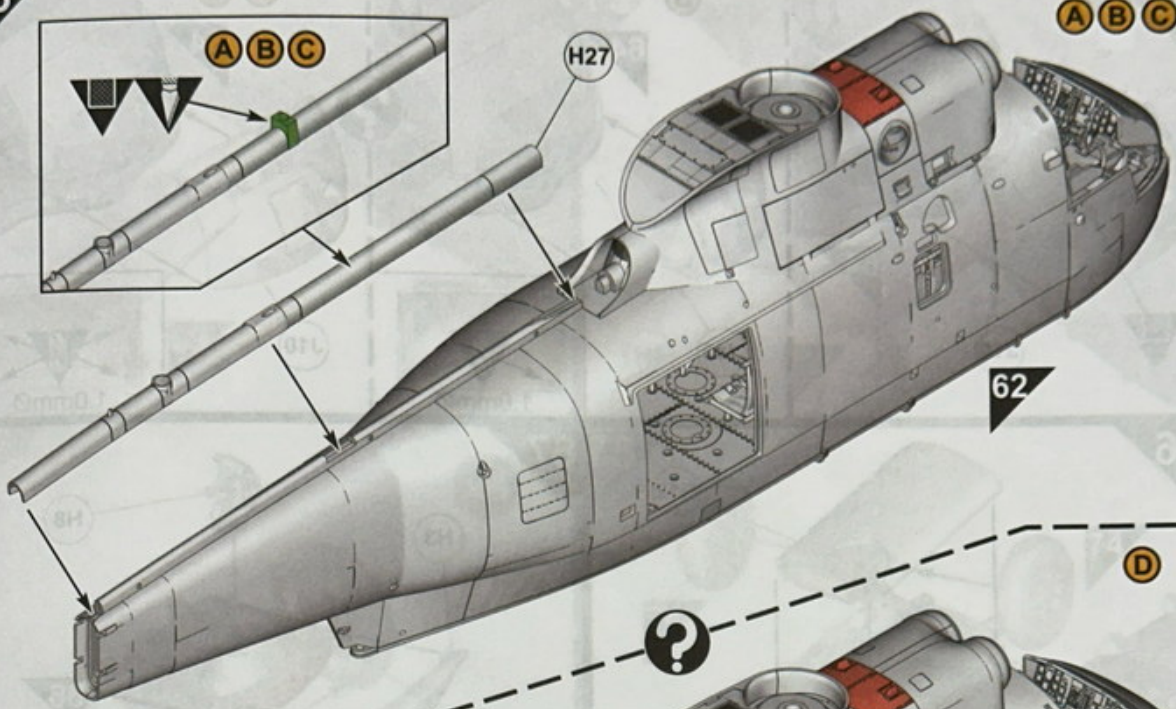

62

D



H26

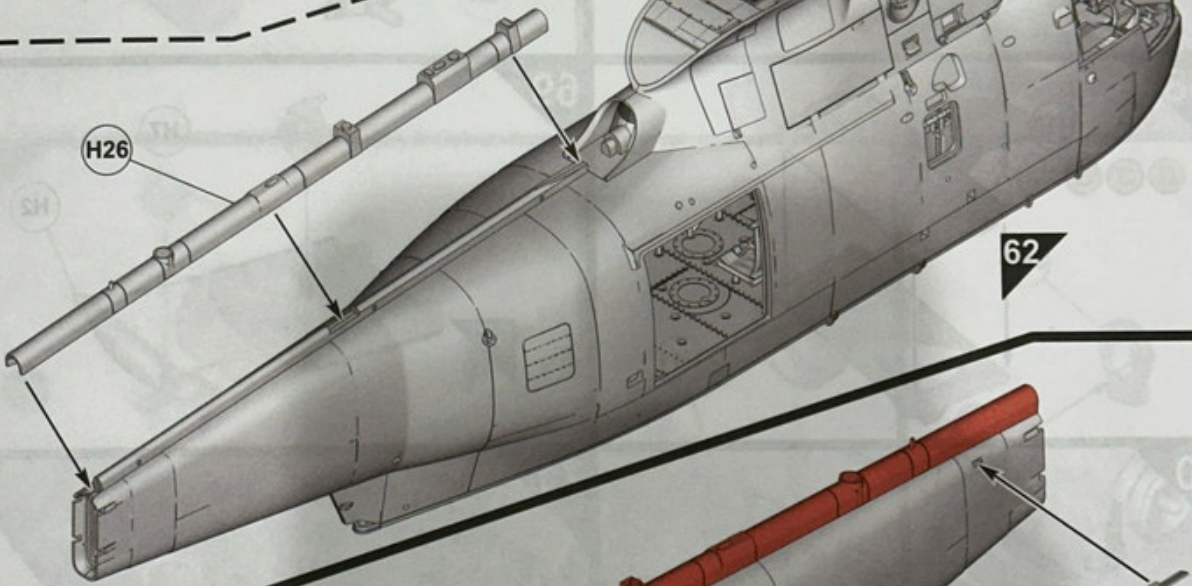

62

64

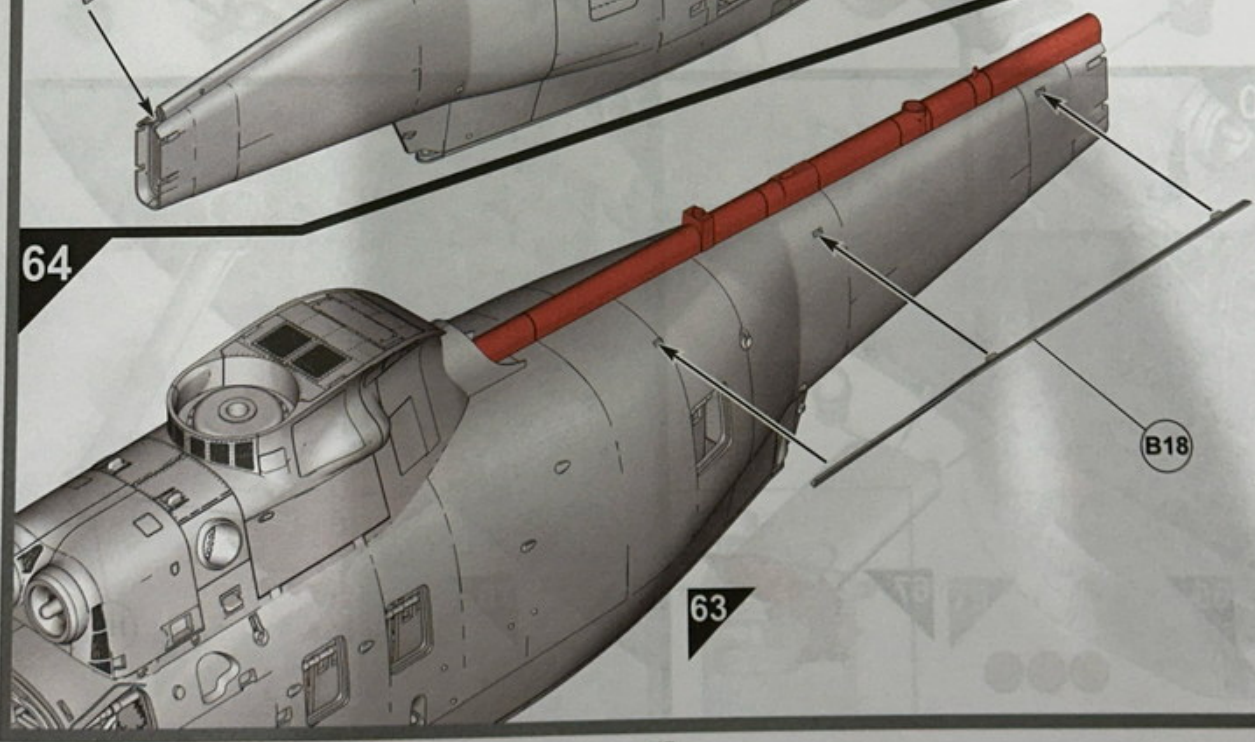

63

B18



65

A

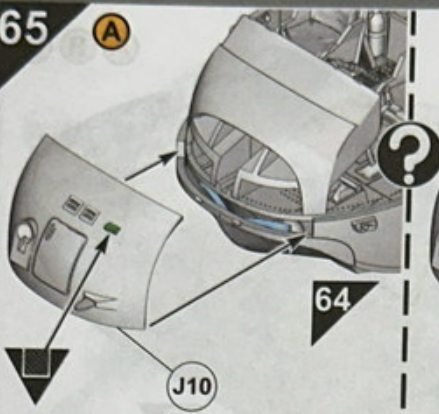

B

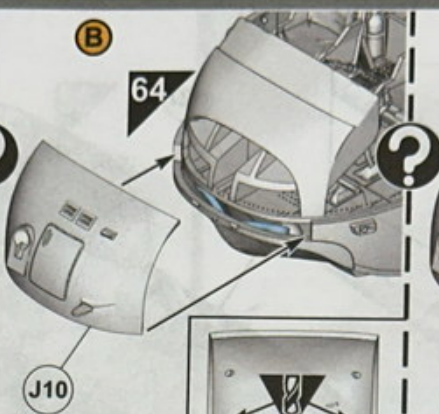

C

D

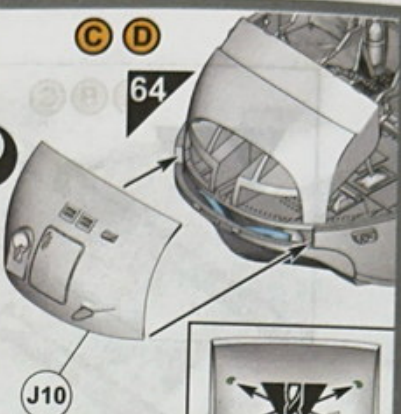

64

64

64

J10

J10

J10

1.0mmØ

1.0mmØ

66

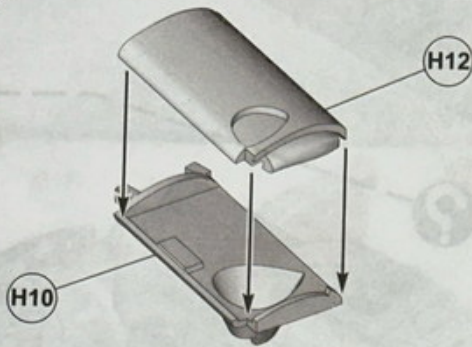

67

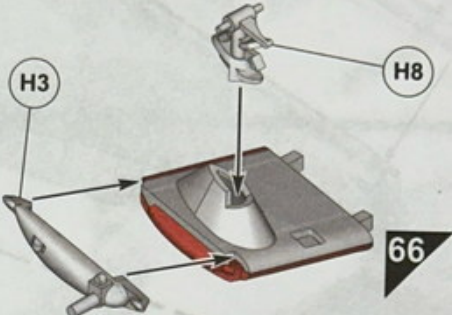

68

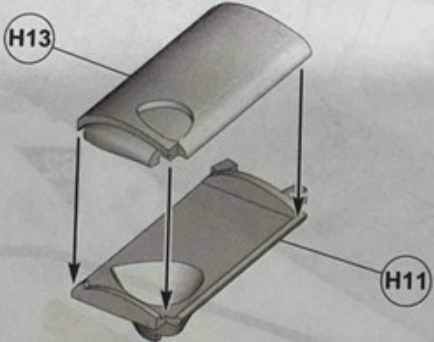

69

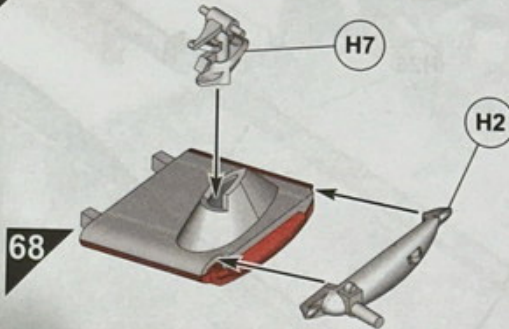

70

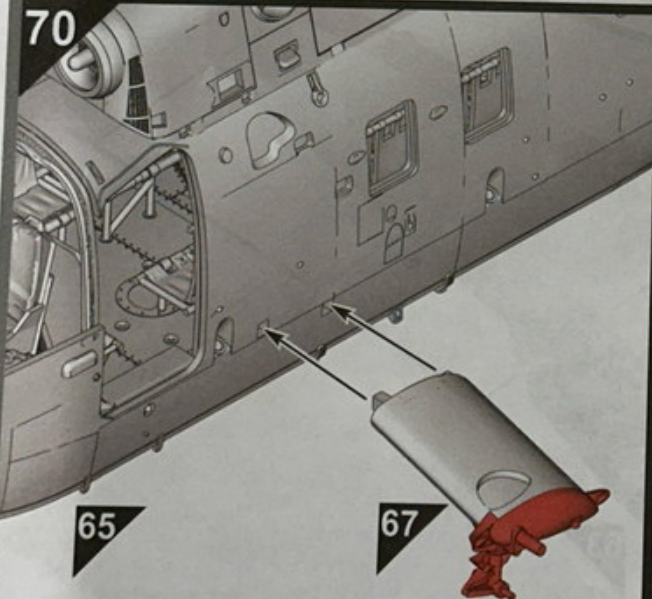

71

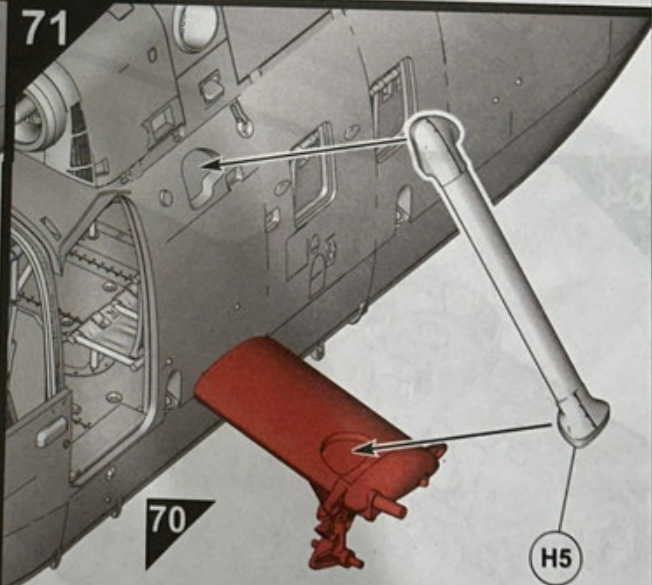

65

67

70

H5

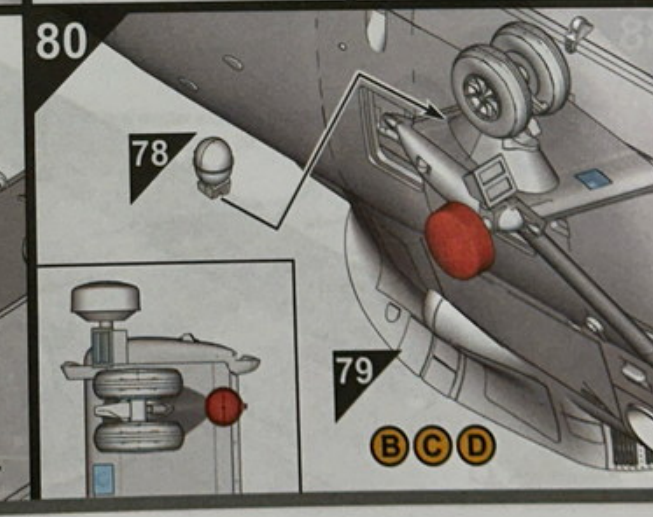
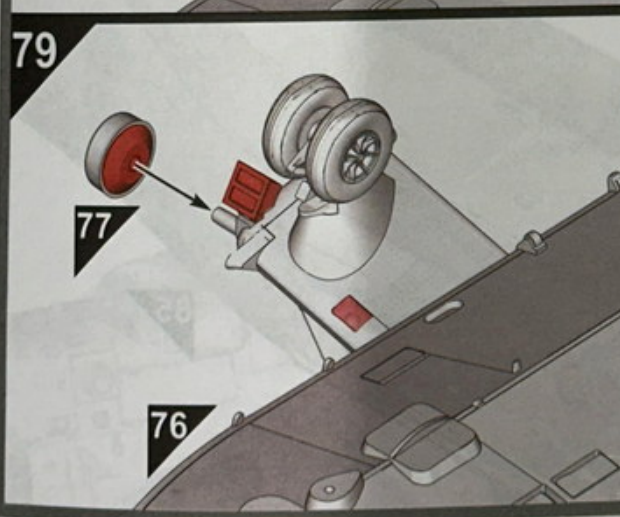
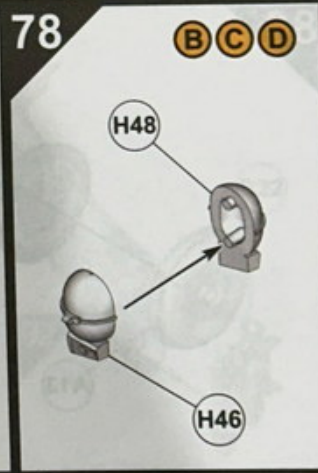
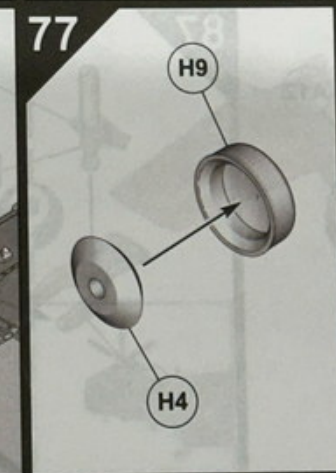
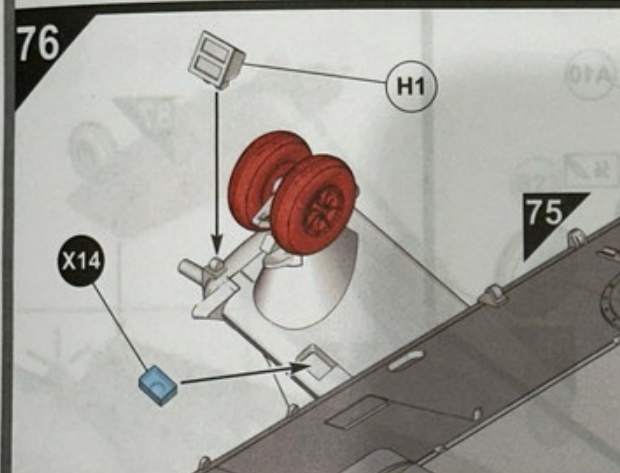
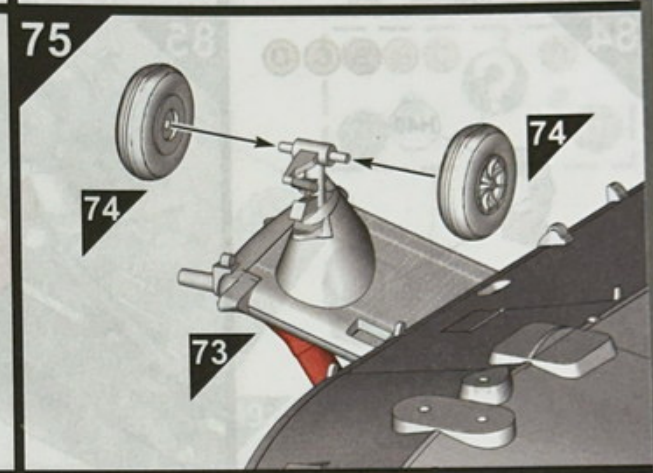
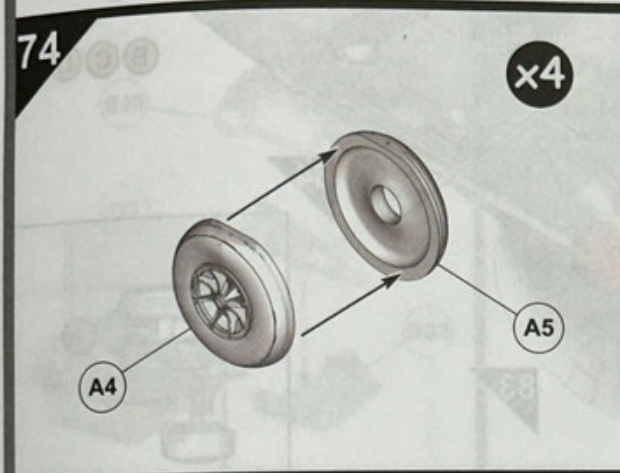
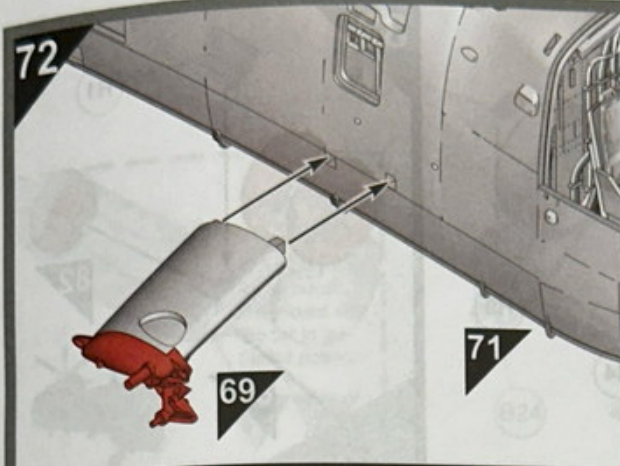

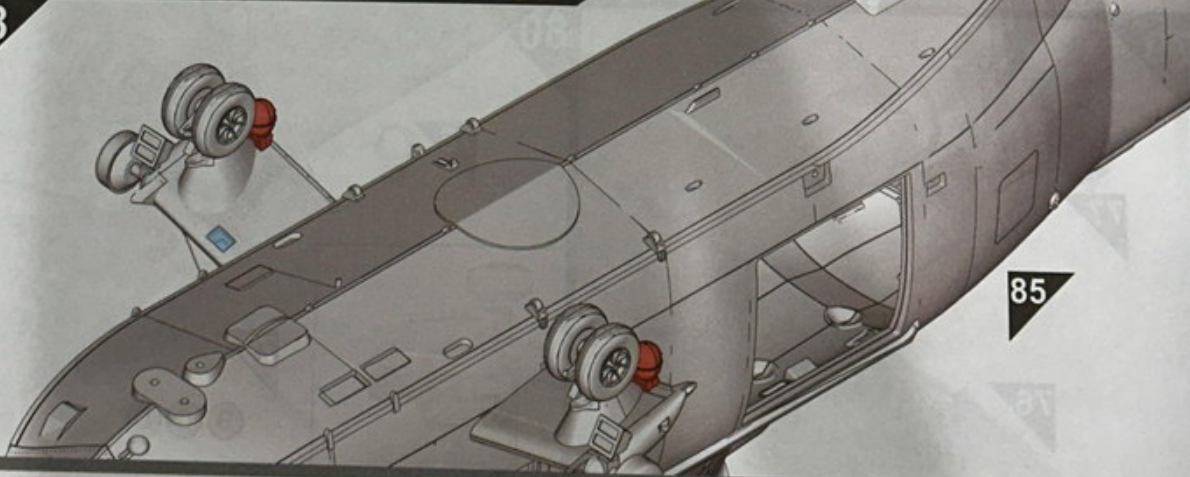
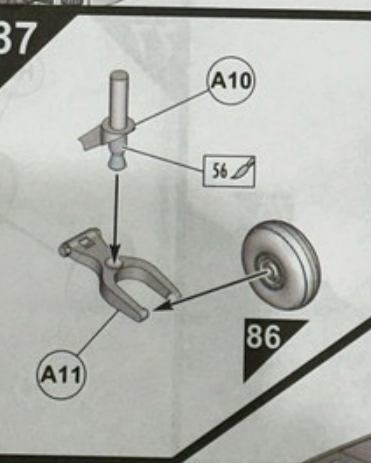
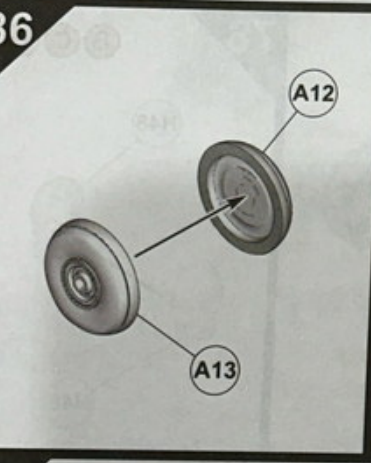
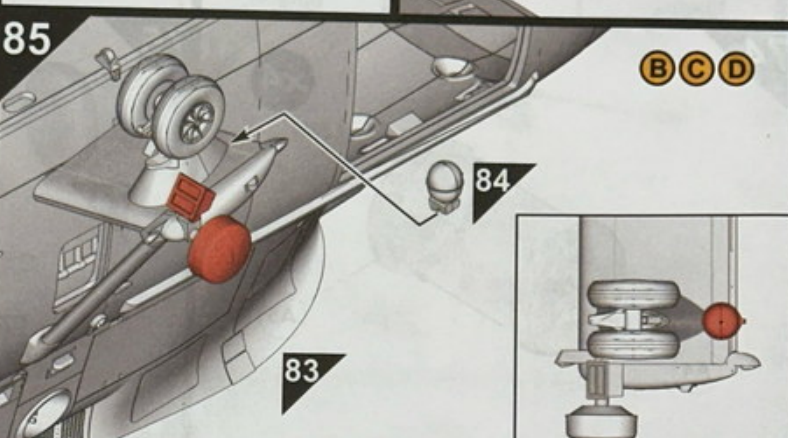
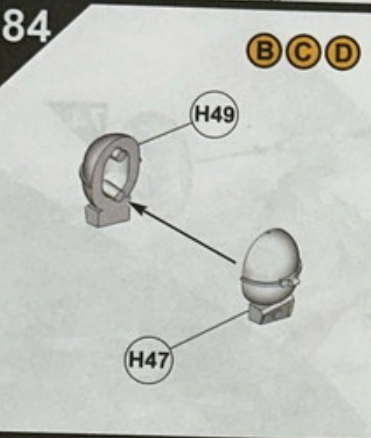
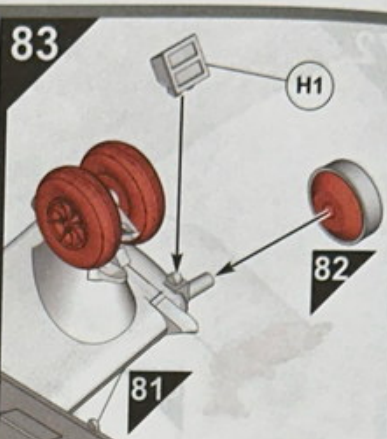
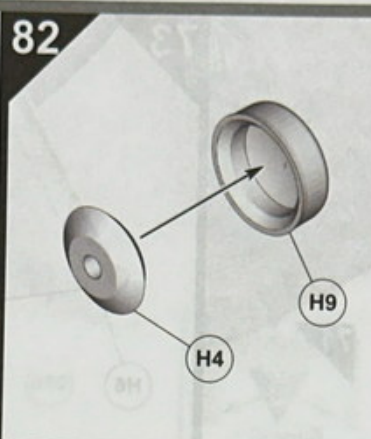
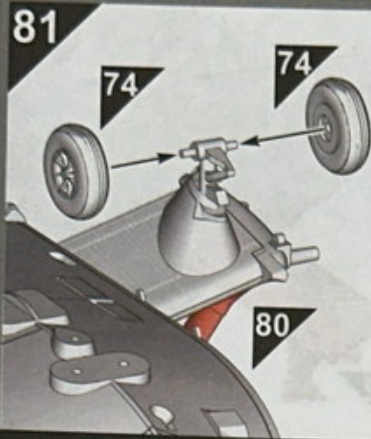

H1

82

89

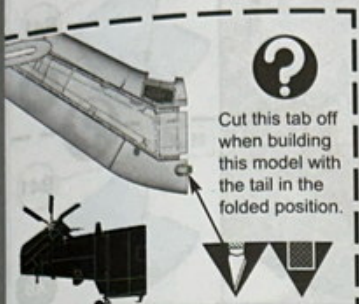

B50

B24

B25

90

B19



B20

91

B30

D3

Do Not Glue

B33

92

90

89

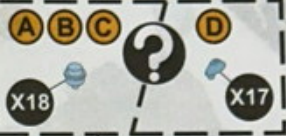

X18

X17

91

93



B23

92



B22

92

94

Note: When building this model with the folded tail option, Follow Step 118 on page 30.

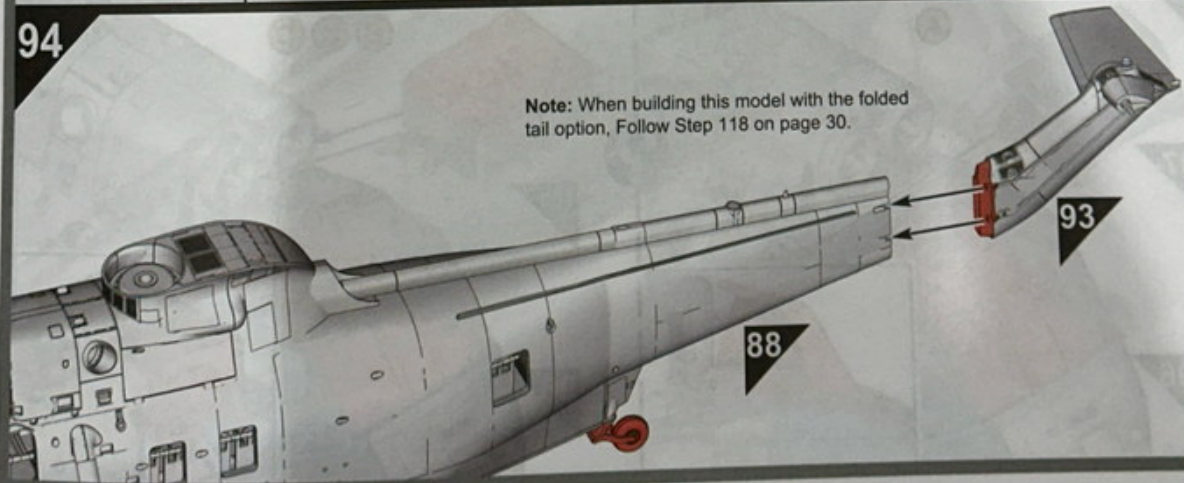

88

93

95

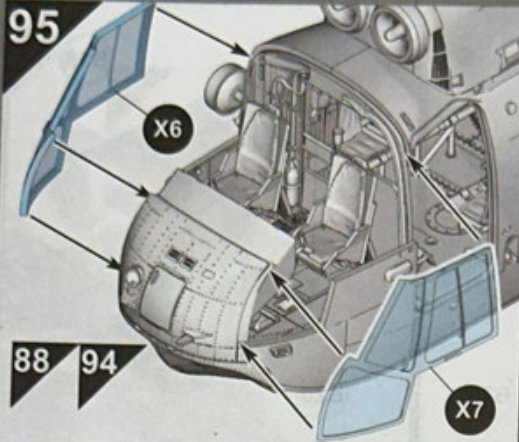

96

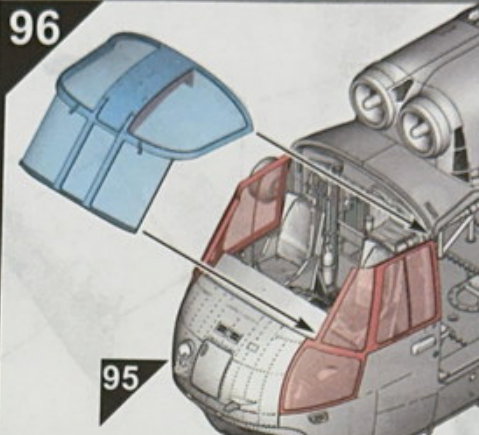

Note: The windscreen option without the wipers X9 has been included to allow a photo-etched wipers to be fitted.

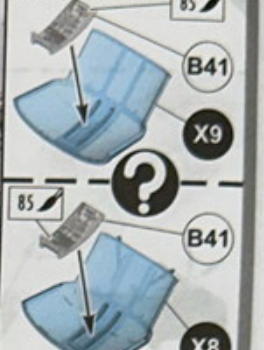

97

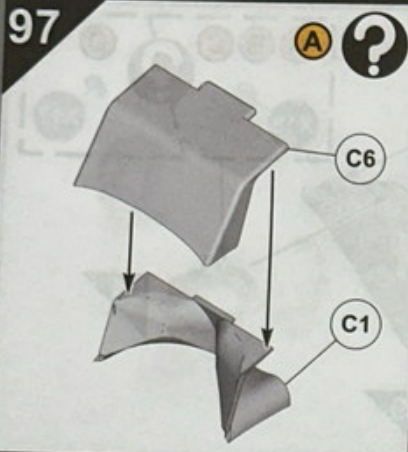

98

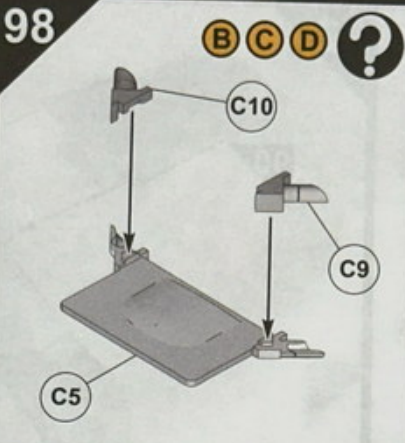

99

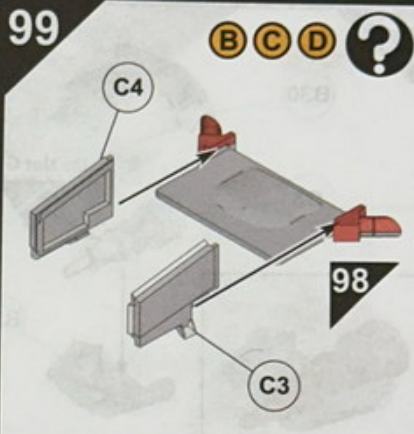

100

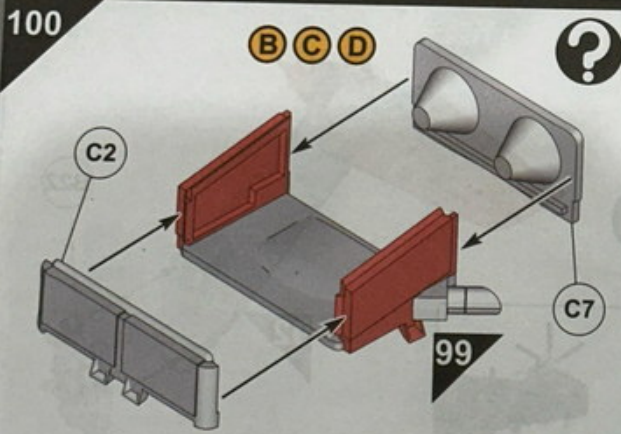

101

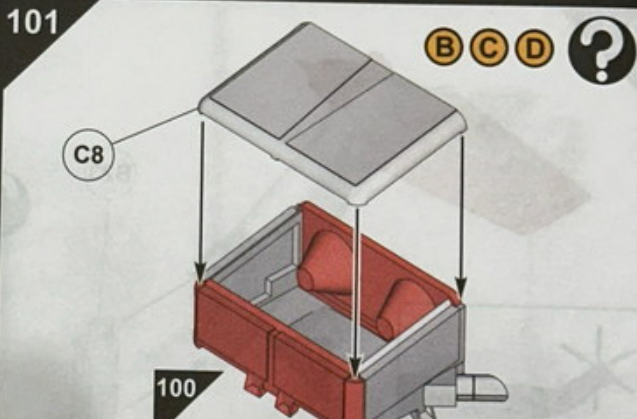

102

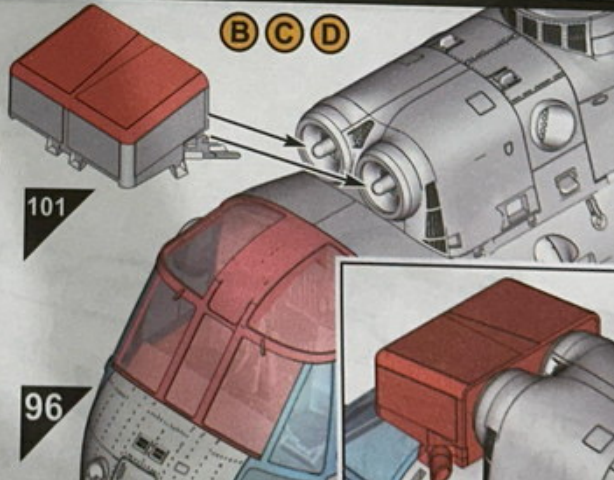
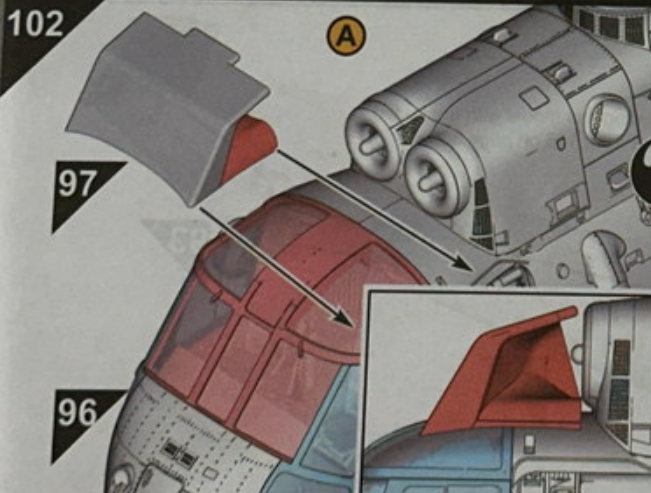

...en option  
X9 has been  
photo-etched

85

B41

X9

B41

X8

98

103

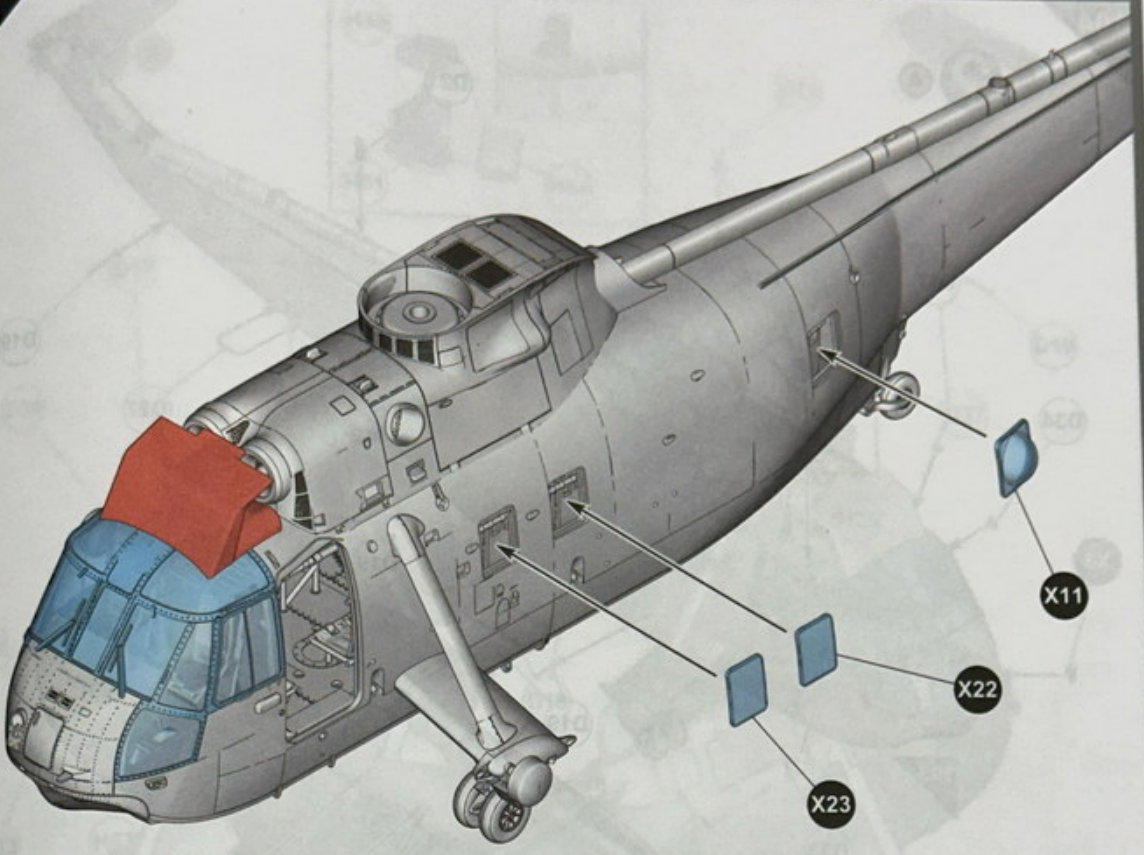

102

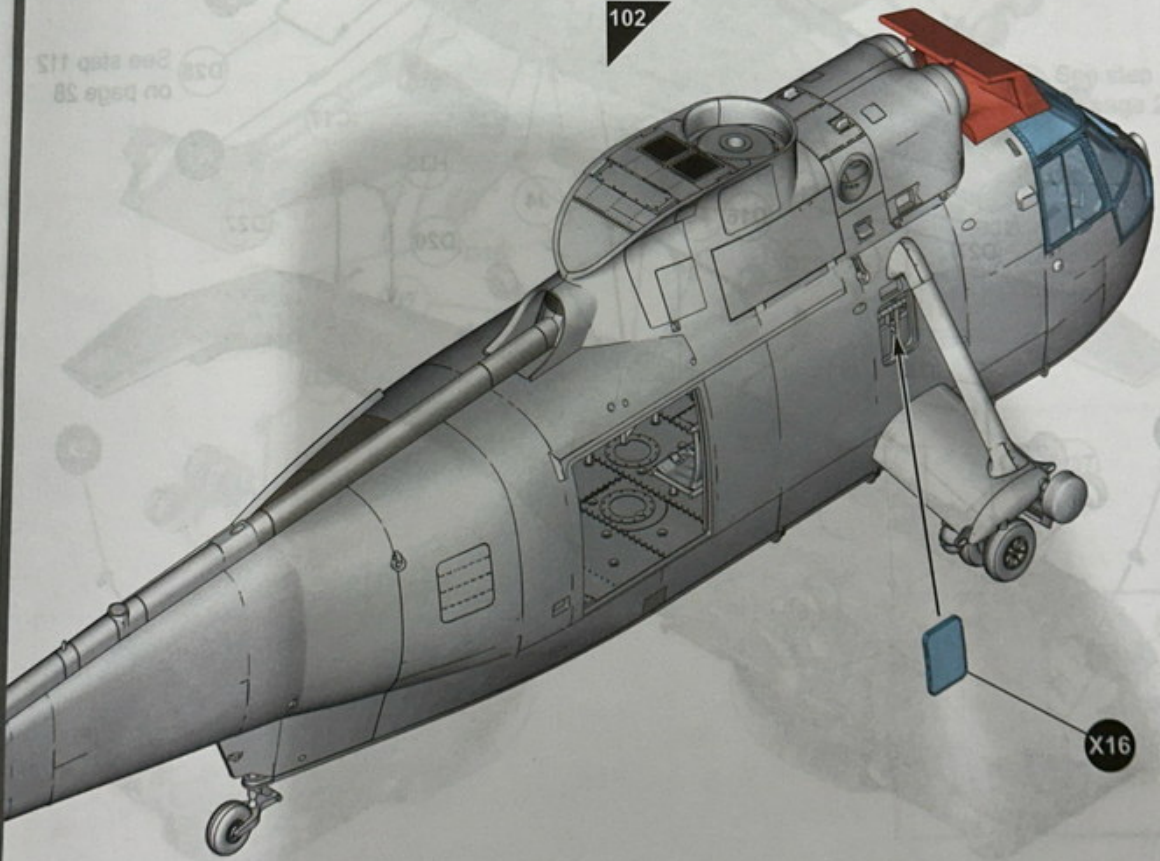

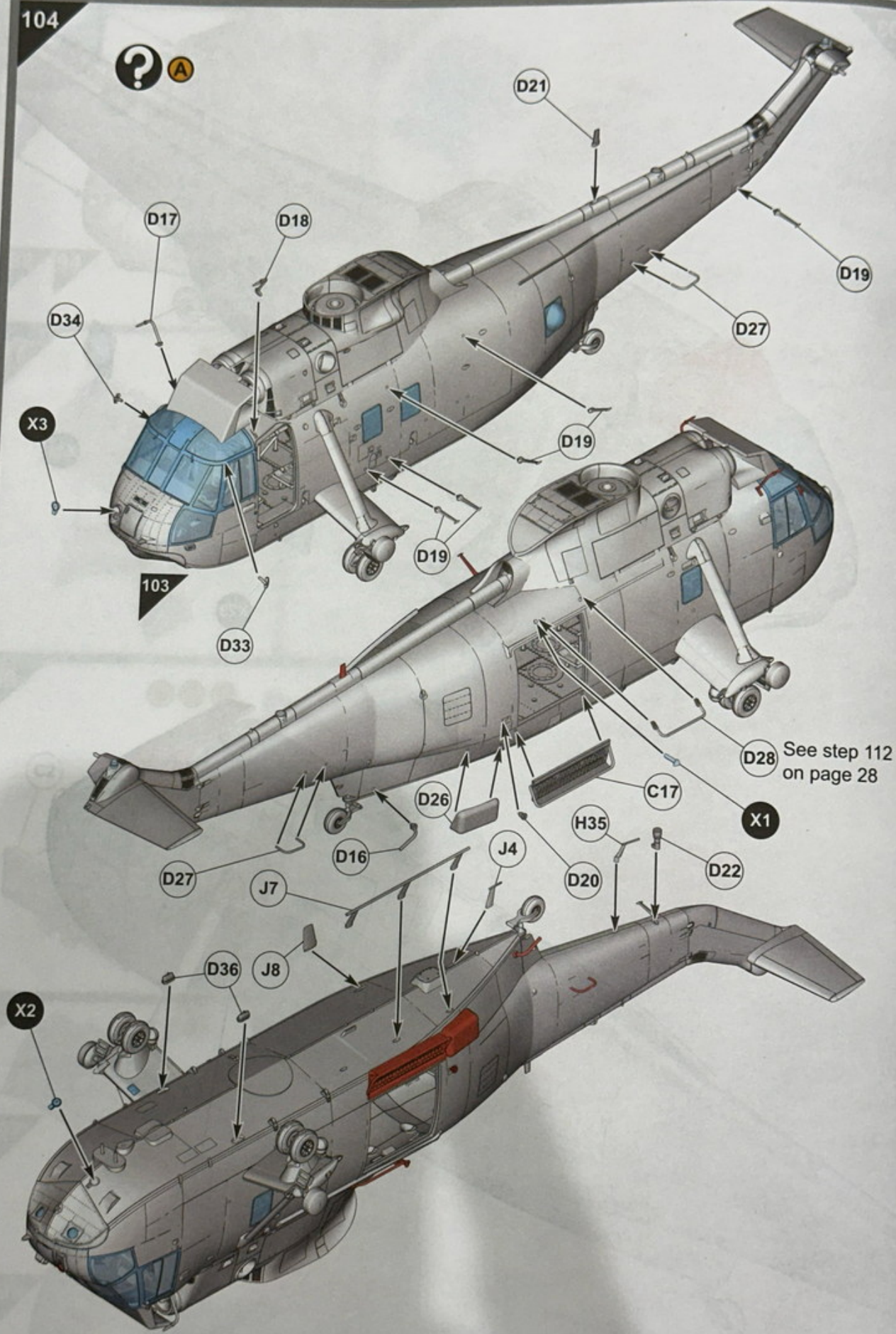

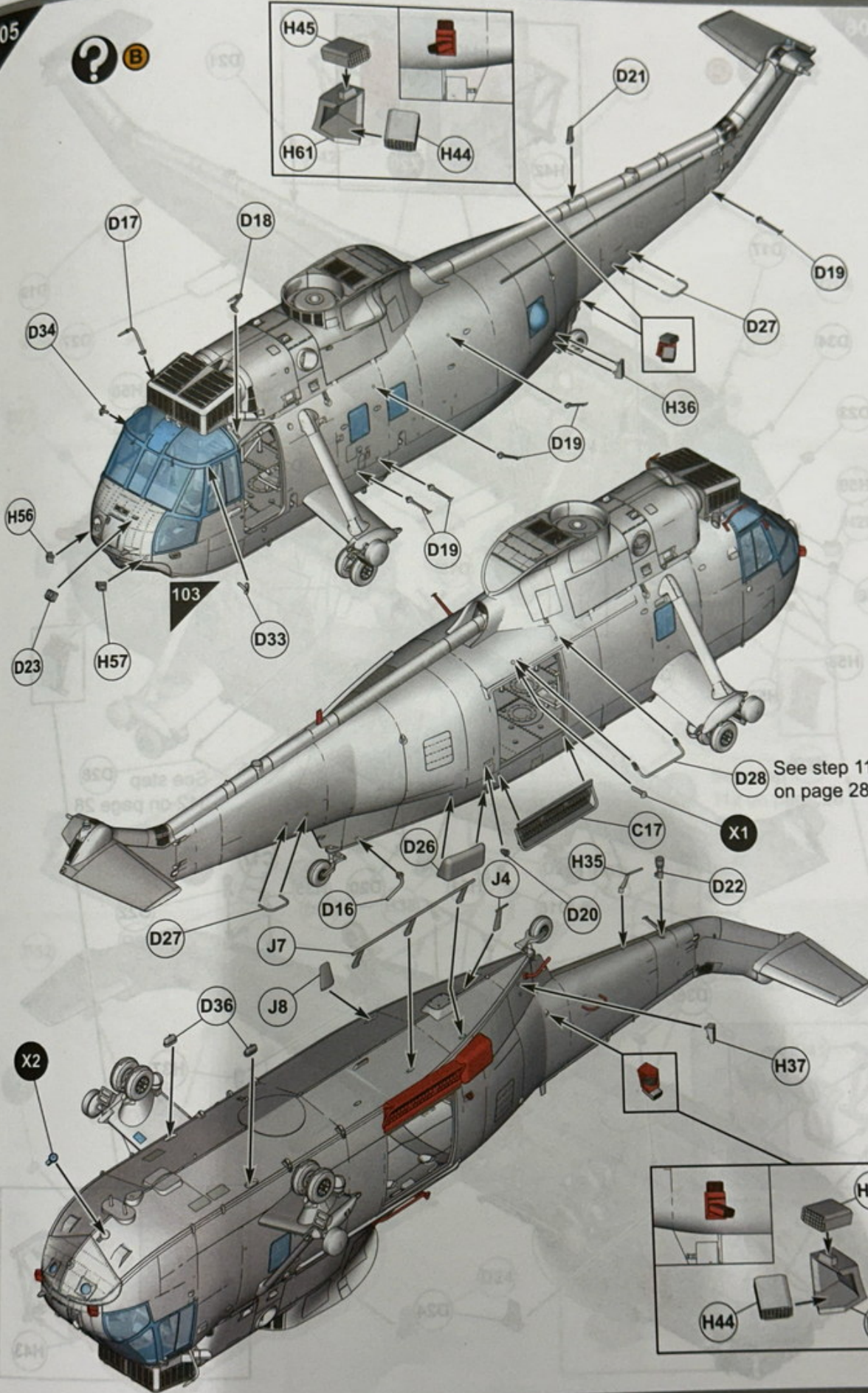
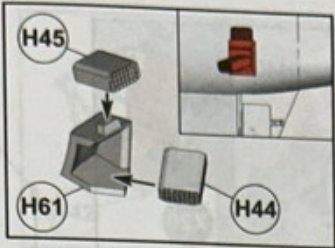

See step 112 on page 28

Step 112 on page 28



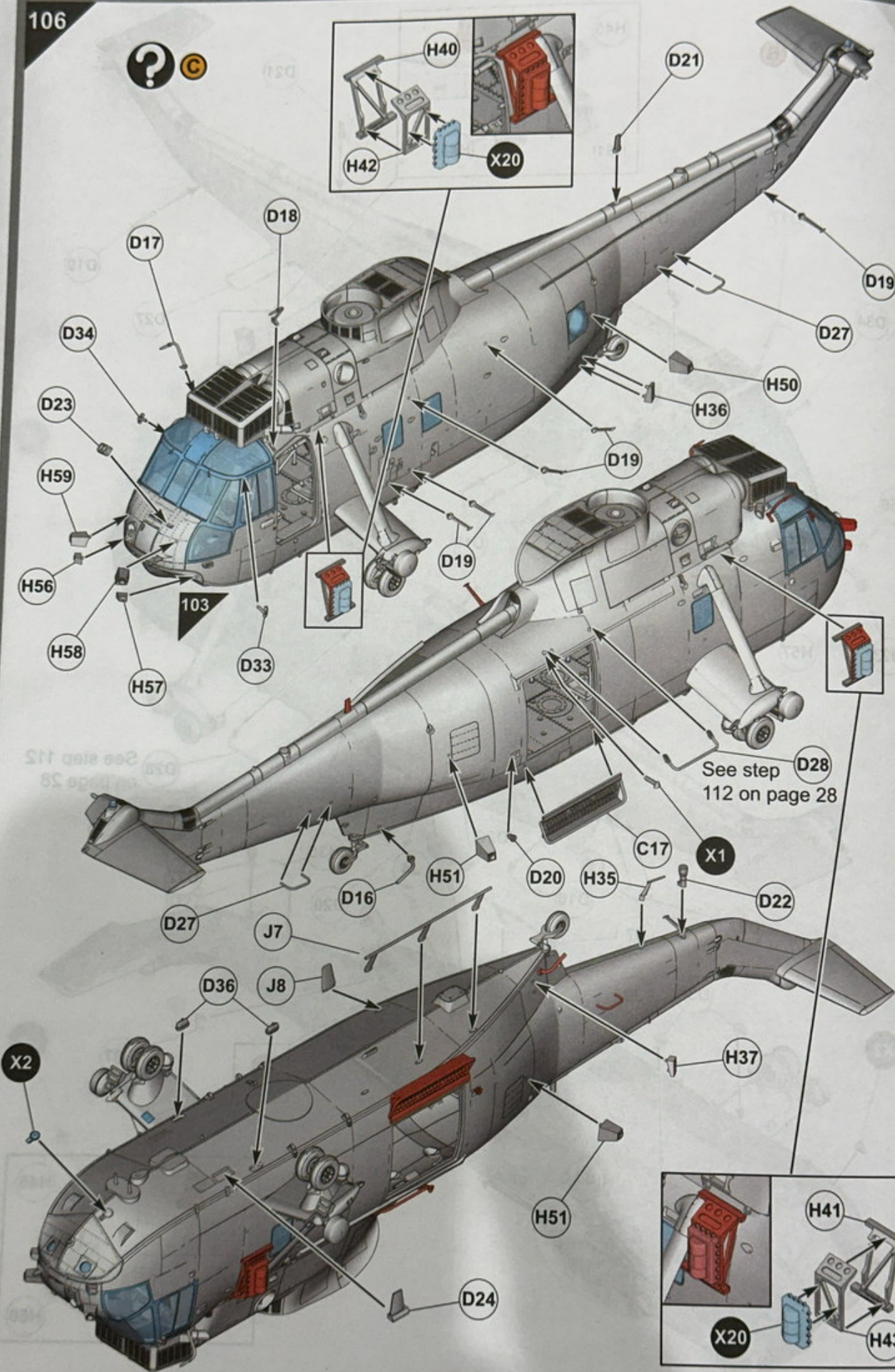
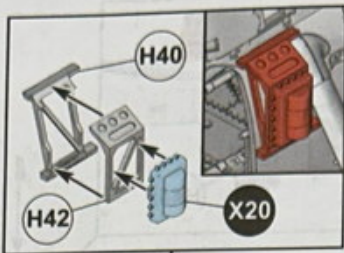

103

See step D28  
112 on page 28

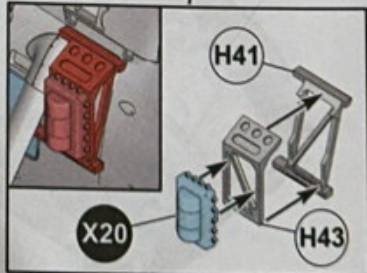

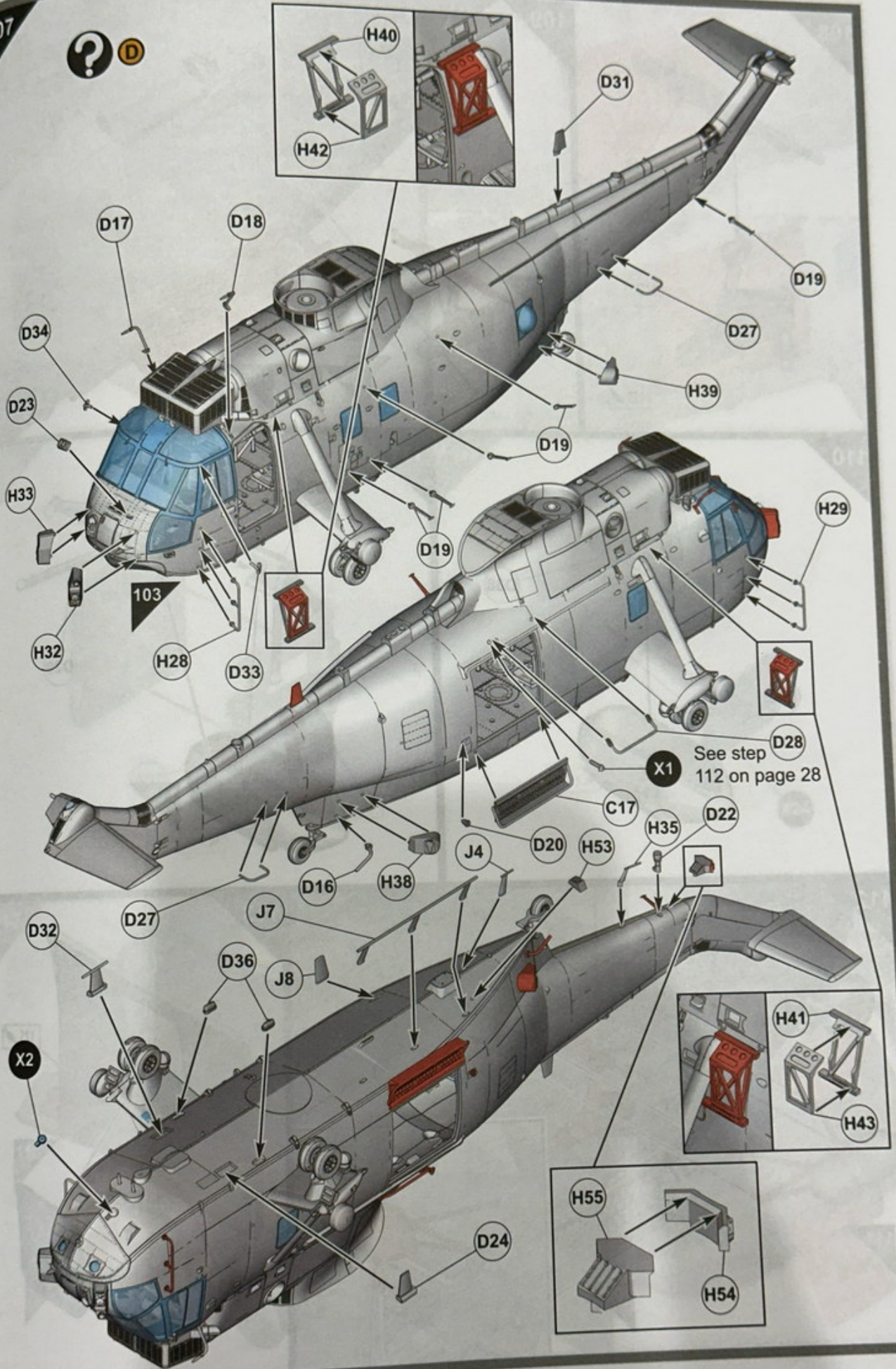

108

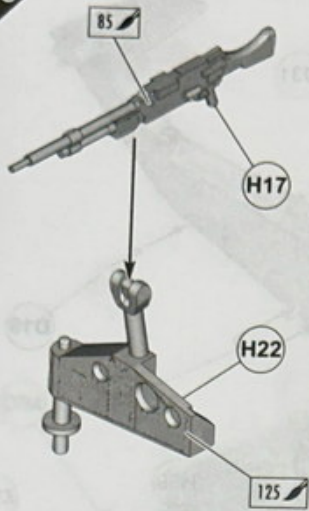

109

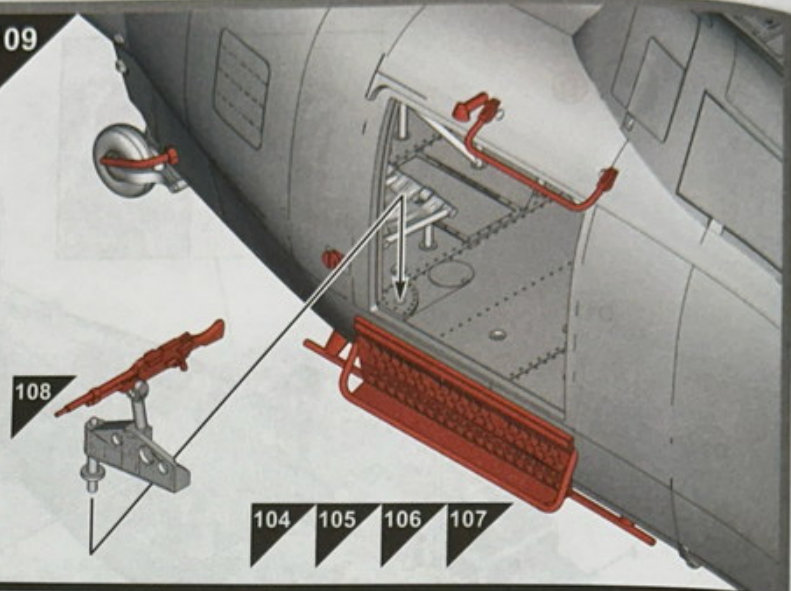

110

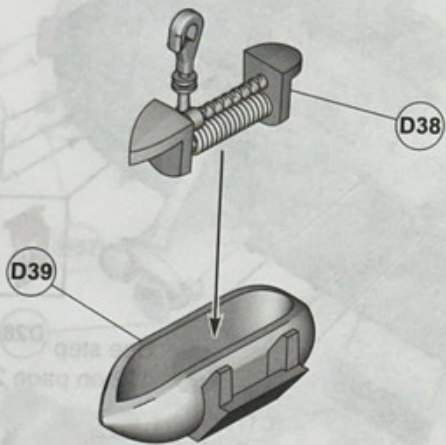

111

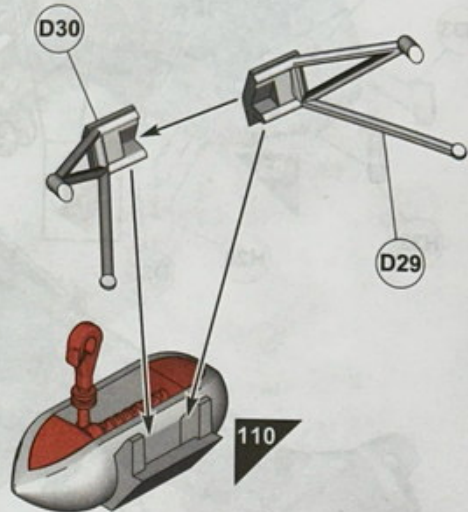

112

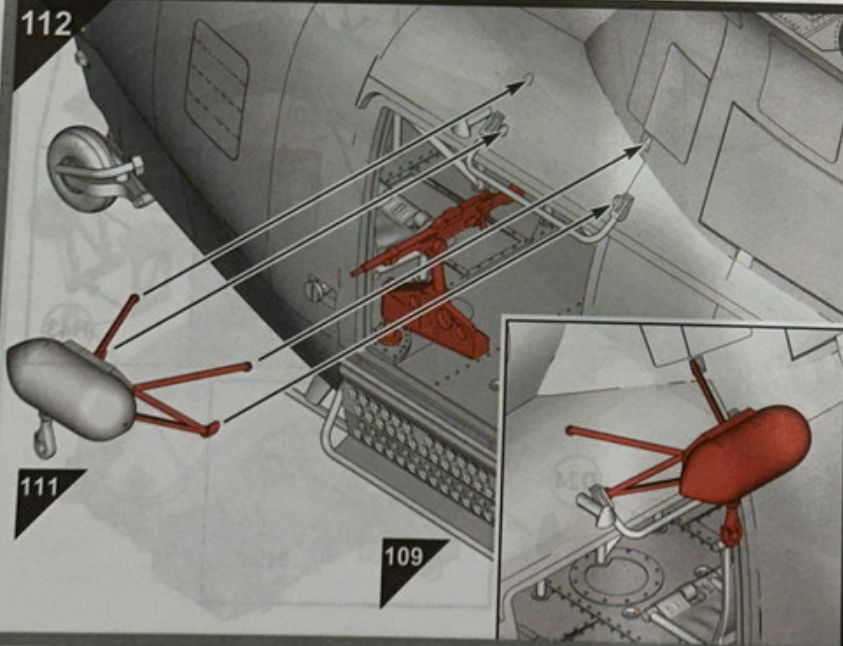

113

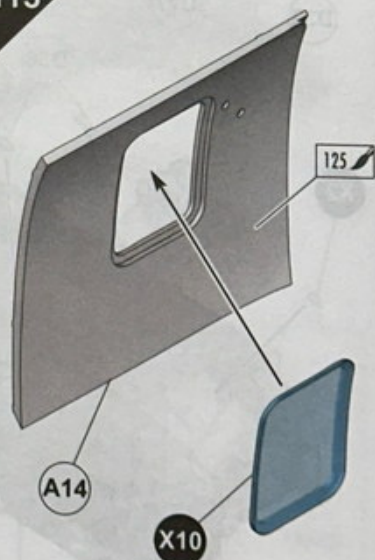

114

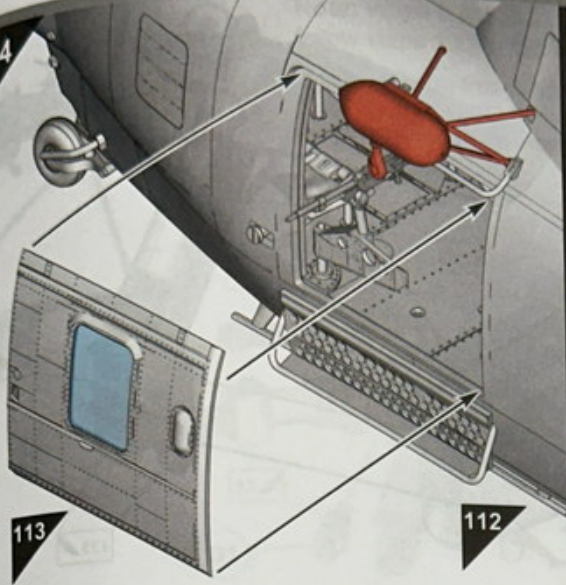

113

112

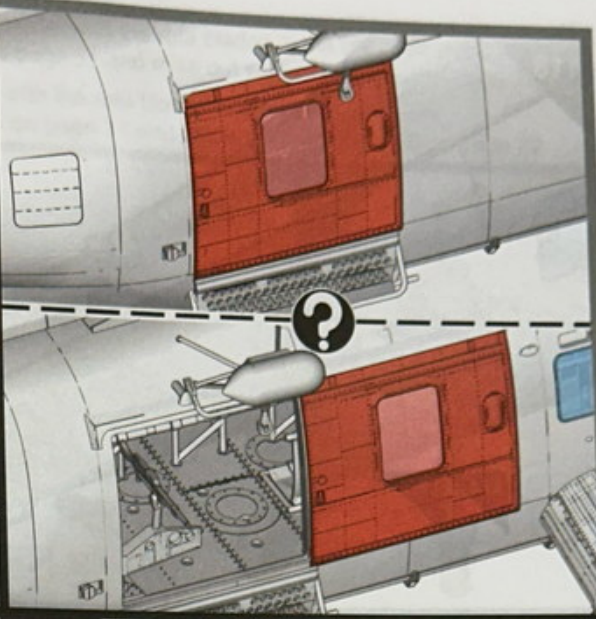

115

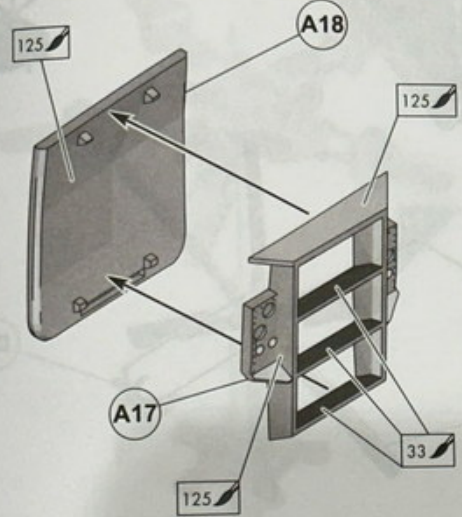

116

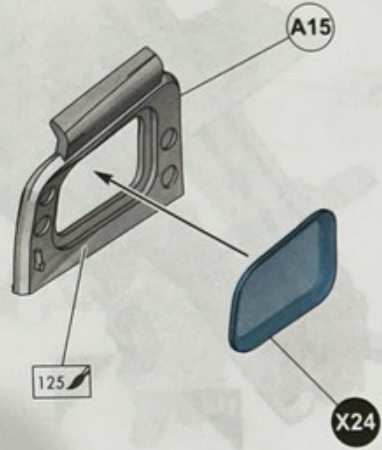

117

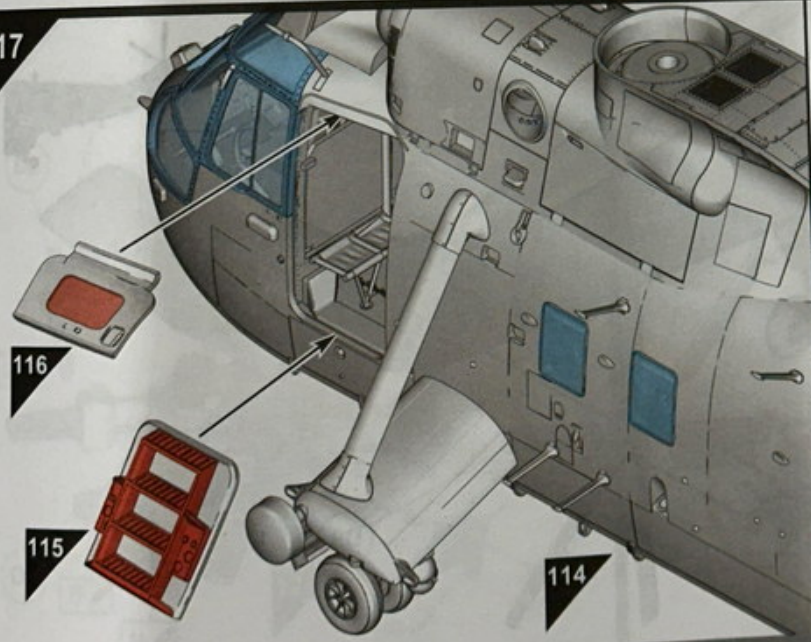

116

115

114

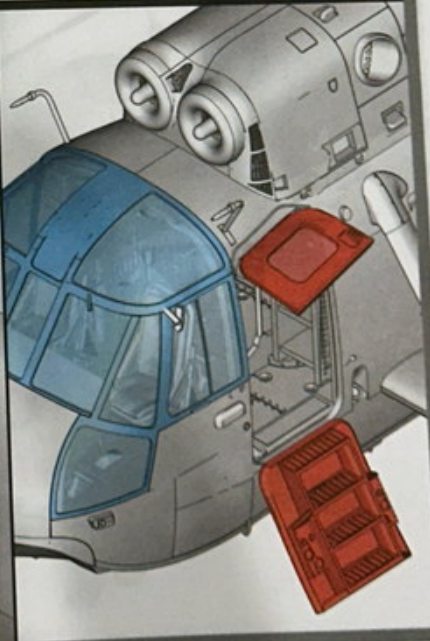

118

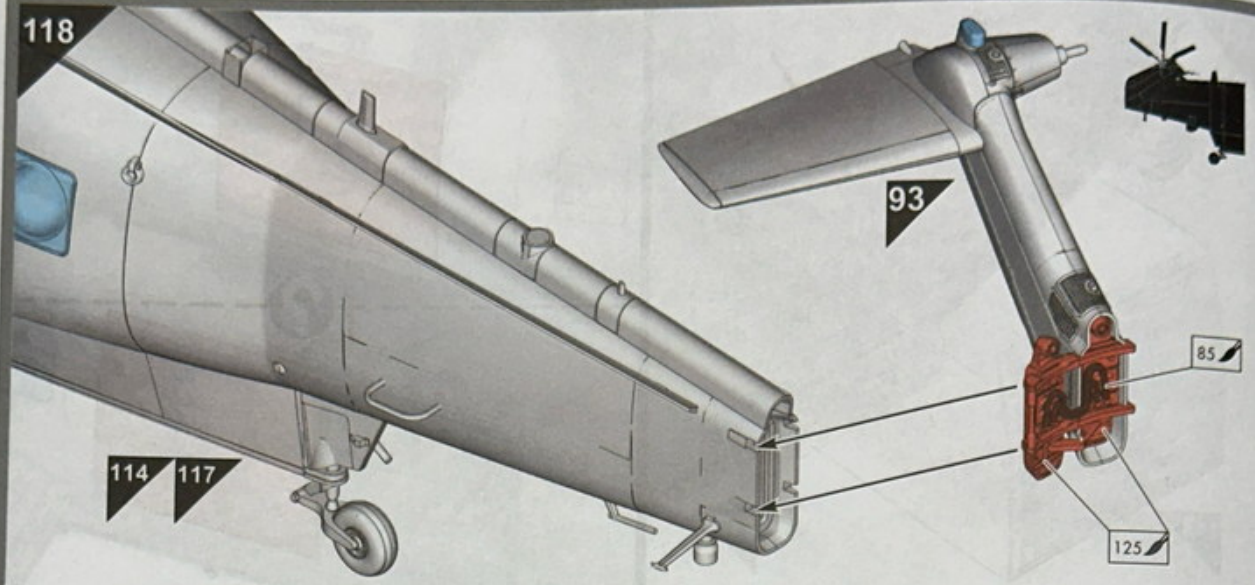

119

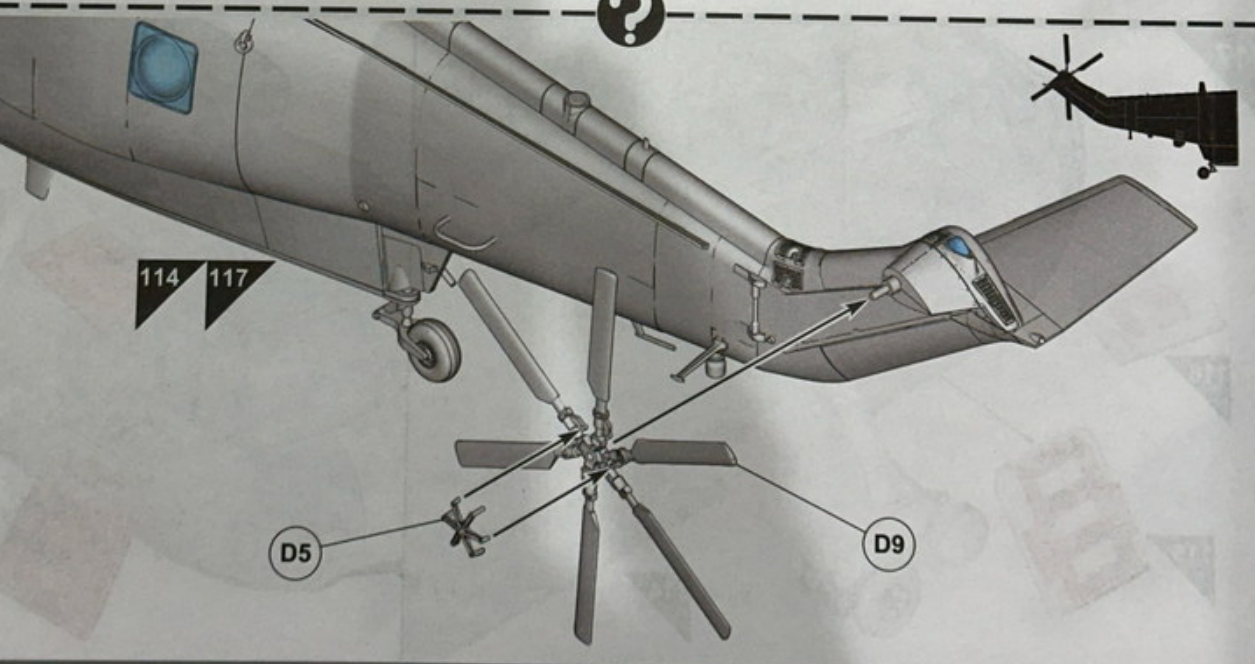
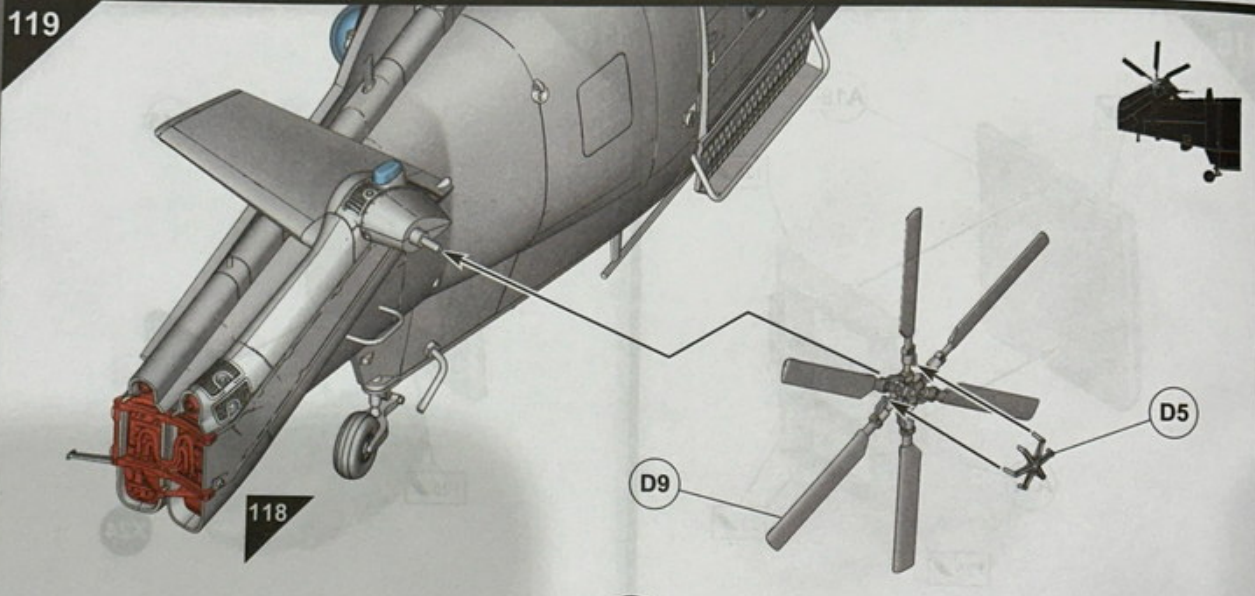



**Note:** When building this model with the rota blades in the unfolded position, follow steps 120 to 125 on page 31 and miss out steps 177 to 132 on page 32. When building this model with the rota blades in the folded position, miss out steps 120 to 125 on page 31 and follow on from step 126 on page 32.

120

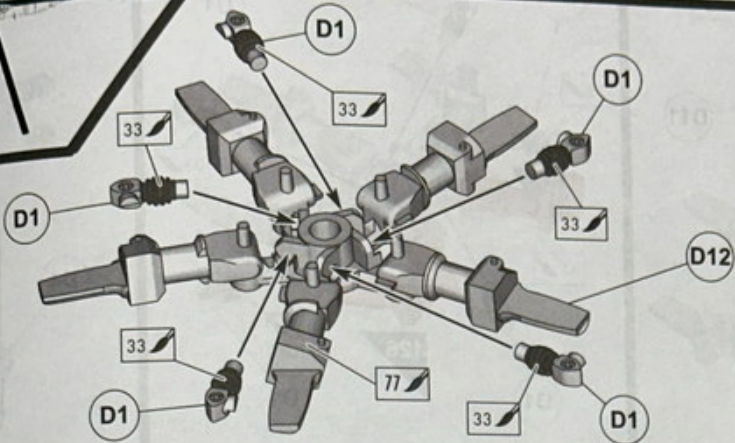

121

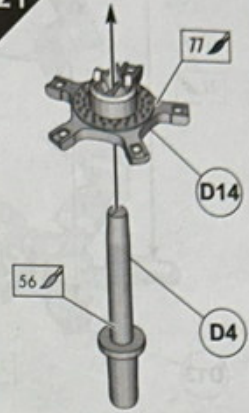

122

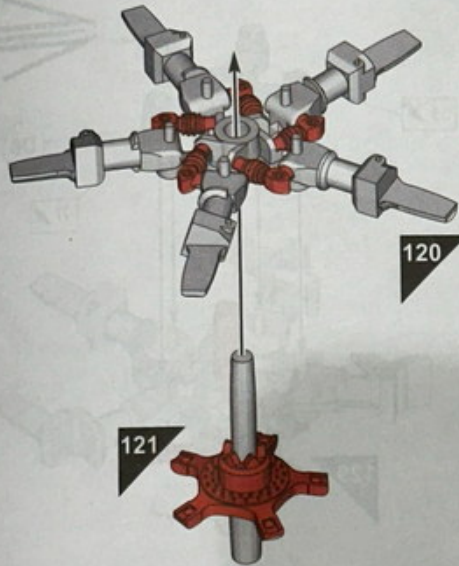

123

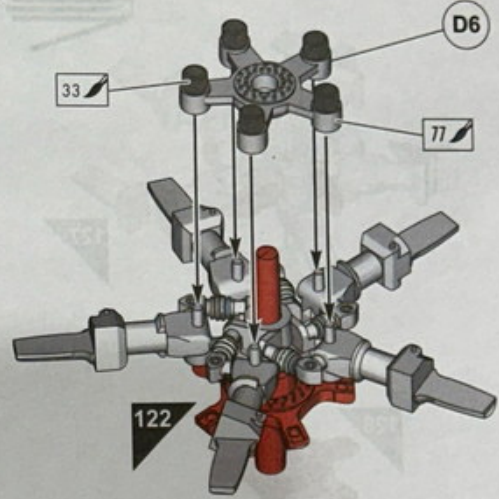

124

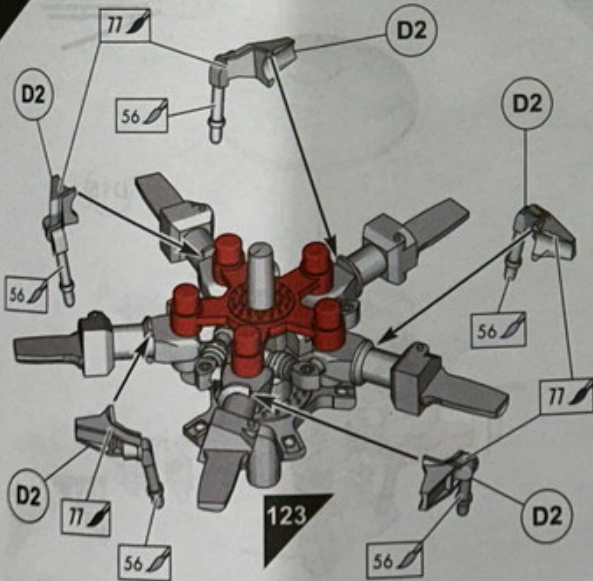

125

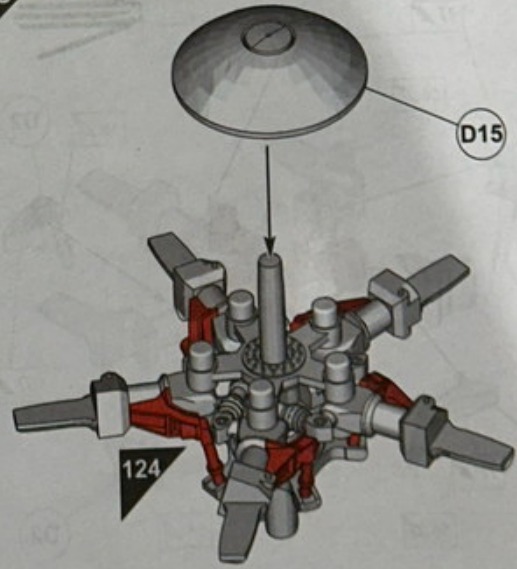

126

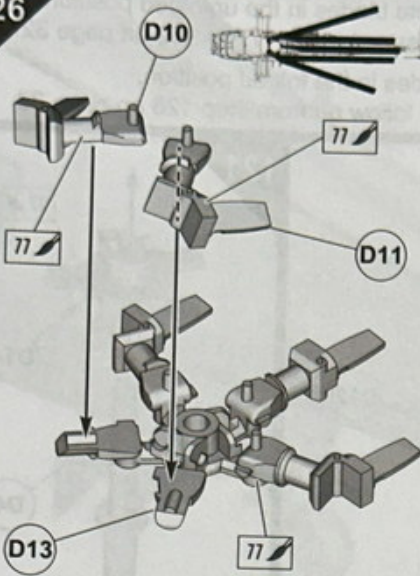

127

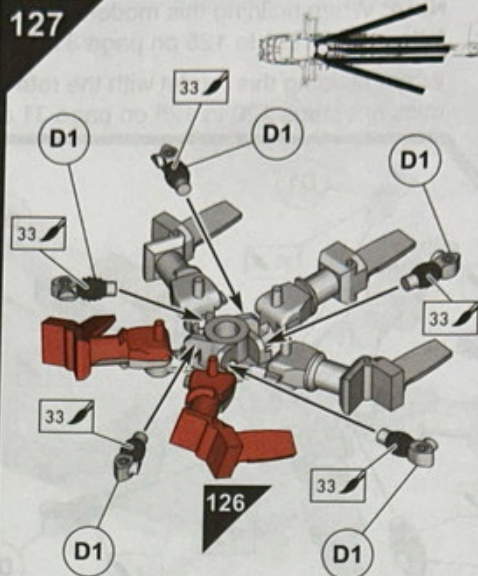

128

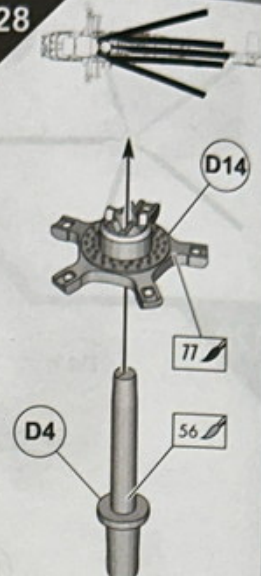

129

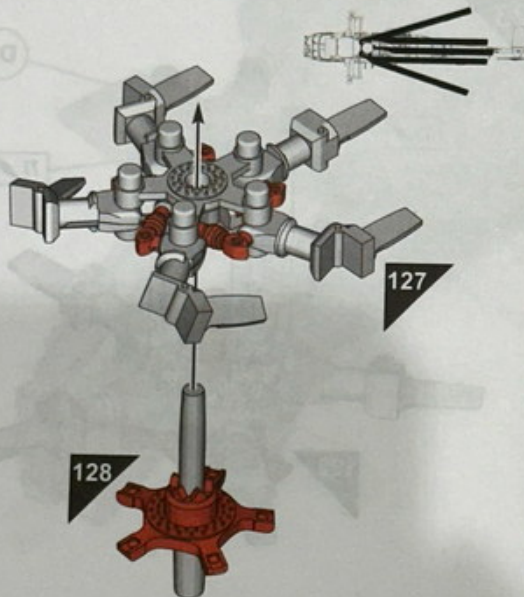

130

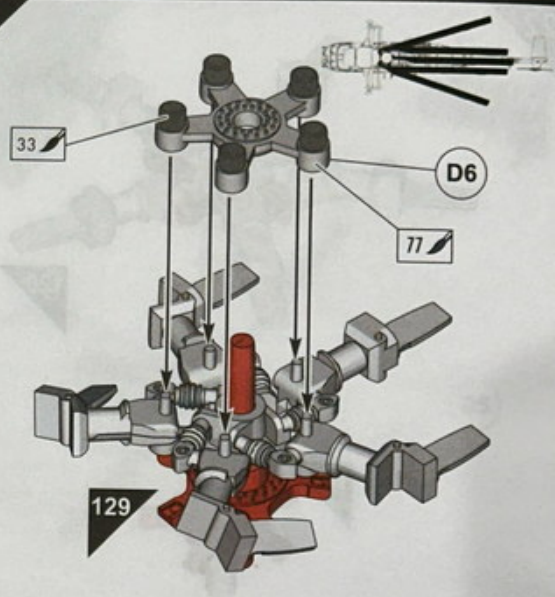

131

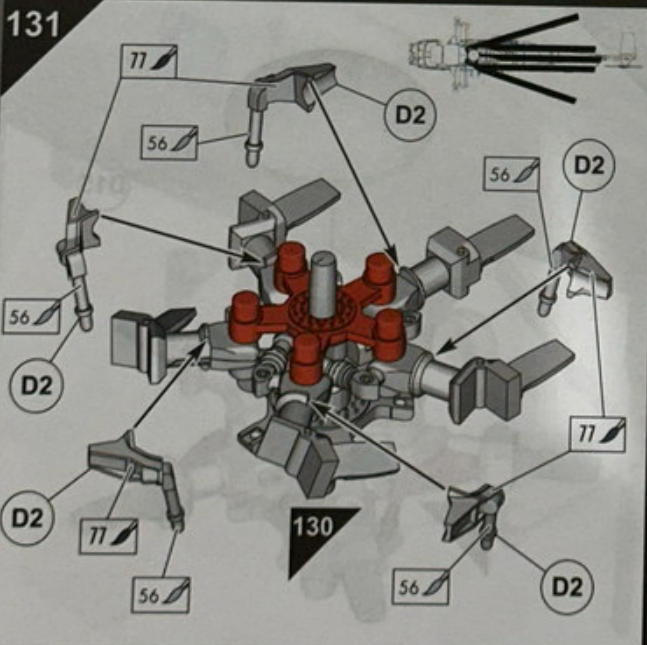

132

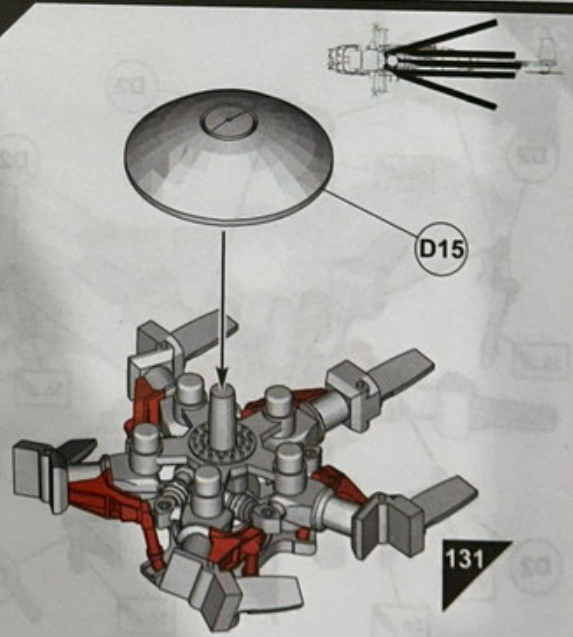

D14

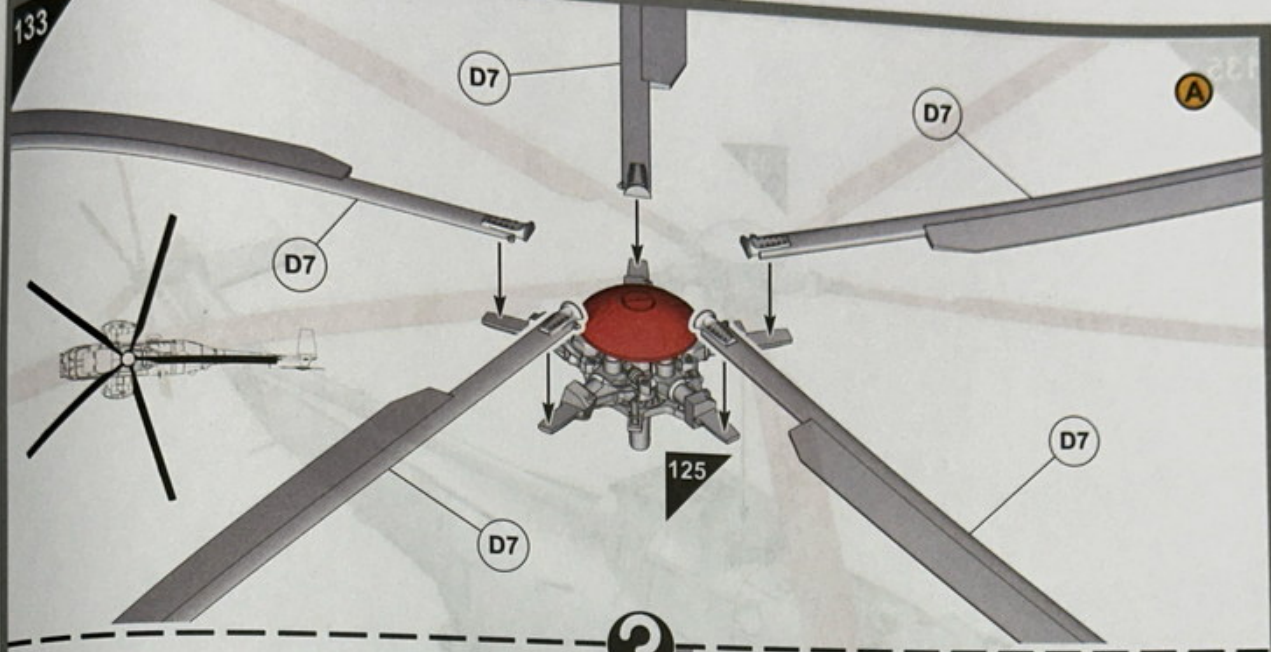

?

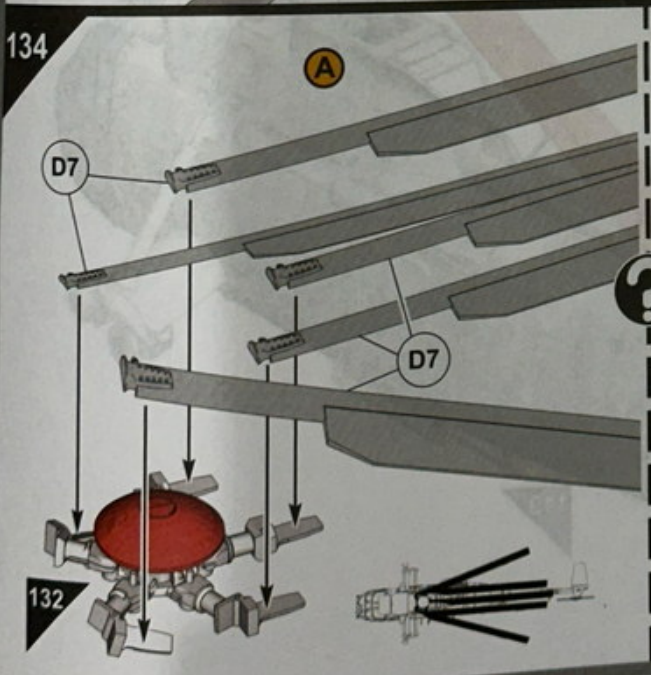
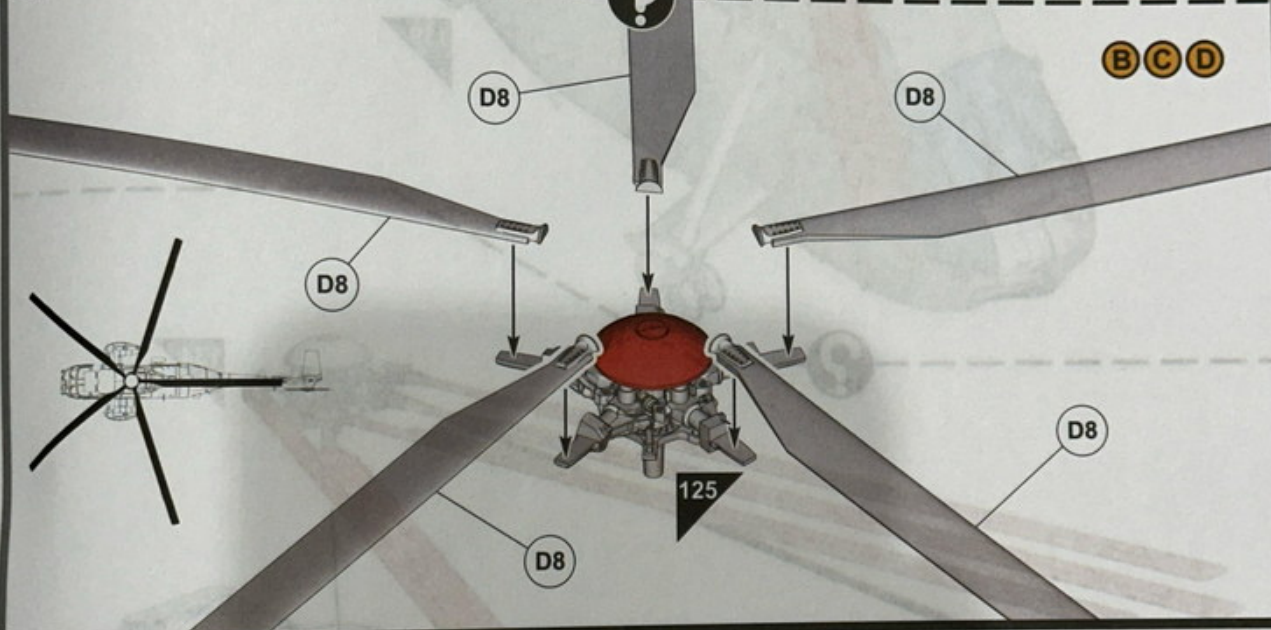

?

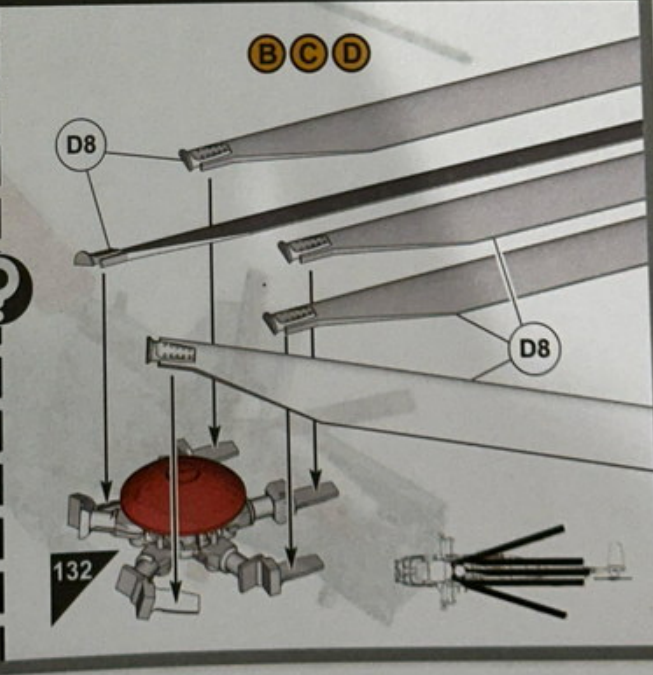



135

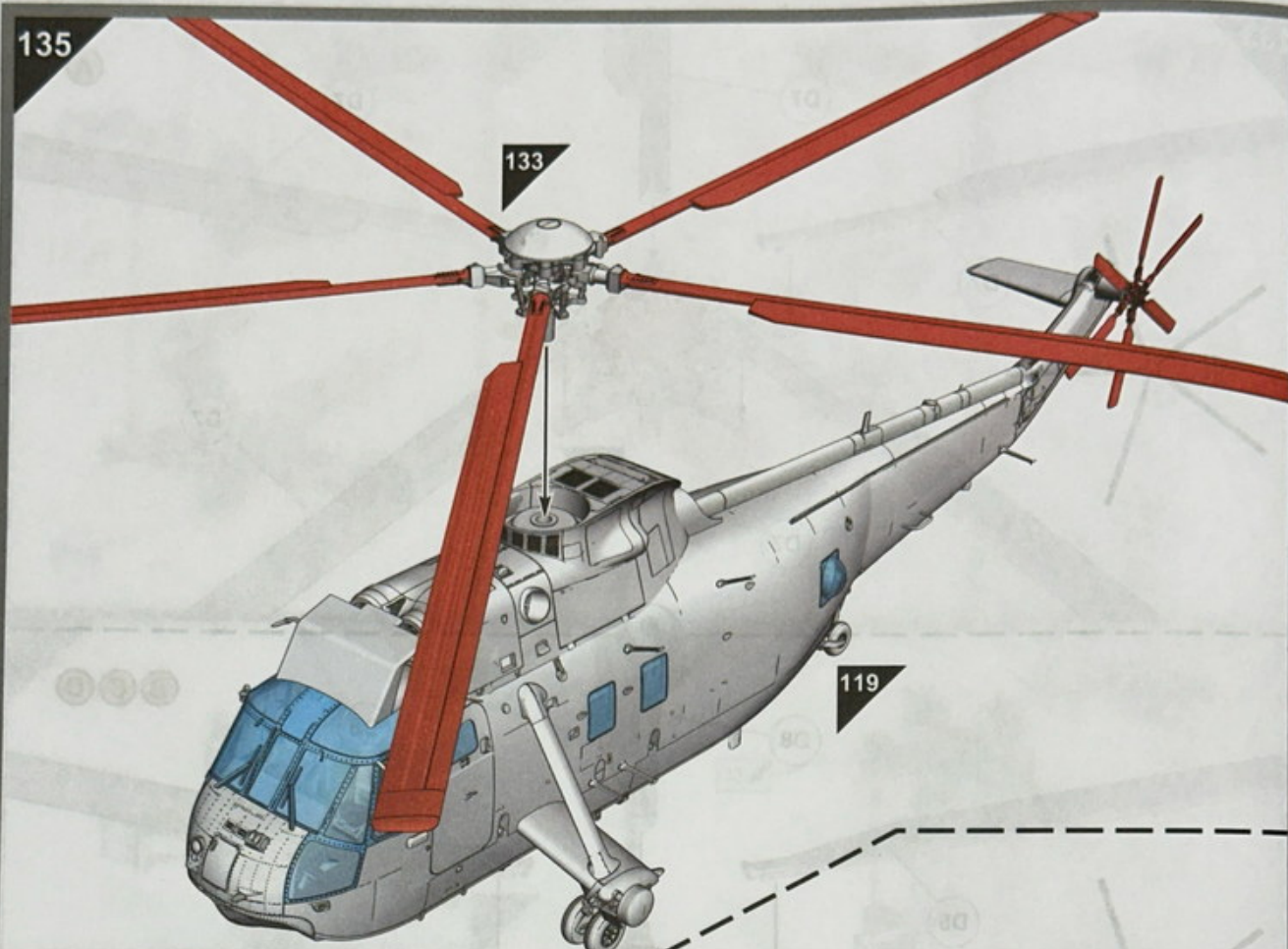

ZD 180  
ROYAL NAVY

UNUNUN

ROYAL NAVY  
ROYAL NAVY

Westland Sea King HC.4  
A11008

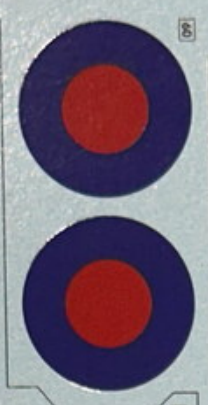

VAVA



ROYAL NAVY  
ROYAL NAVY

ZA298  
ZA298

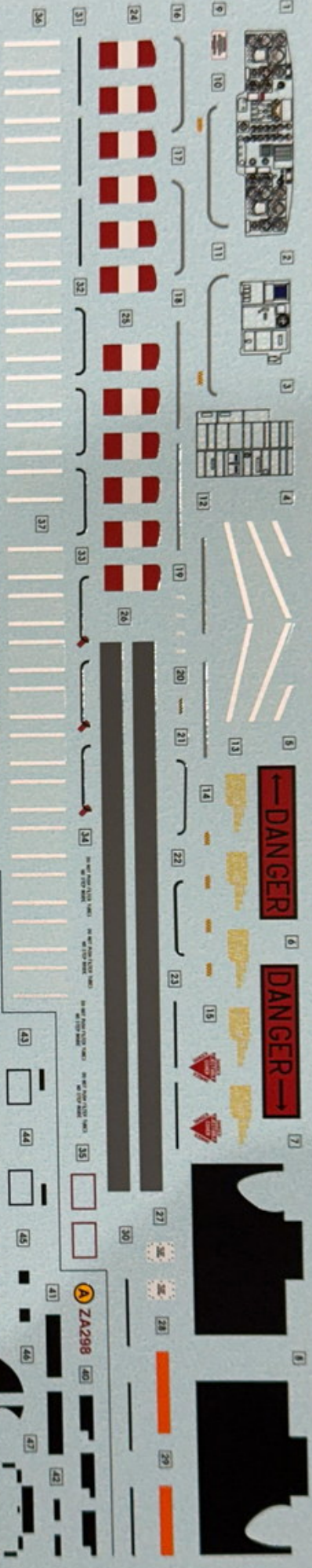

DANGER

DANGER

ZF122

ZA312

ZA298

V

DANGER DANGER

VA

V

B

VA

V

V

B

## B Westland Sea King HC.4

ZA312, No.845 Naval Air Squadron, Operation 'Granby'/Desert Storm, Fleet Air Arm, Royal Navy, King Khalid Military City, Saudi Arabia, January-February 1991.

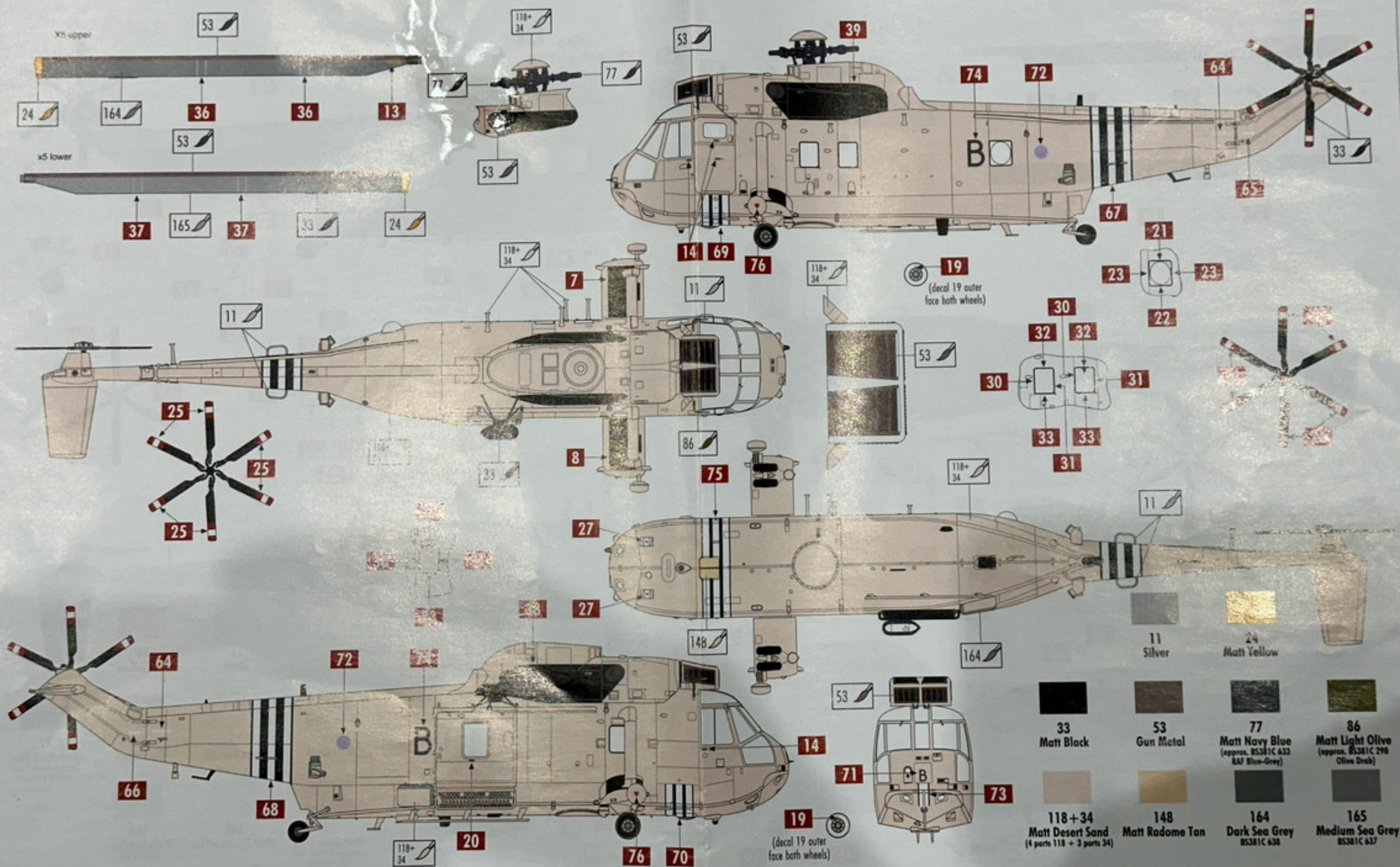

11	Silver	24	Matt Yellow
33	Matt Black	53	Gun Metal
77	Matt Navy Blue (approx. BS381C 633 RAF Blue-Grey)	86	Matt Light Olive (approx. BS381C 298 Olive Drab)
118+34	Matt Desert Sand (4 parts 118 + 3 parts 34)	148	Matt Radome Tan
164	Dark Sea Grey BS381C 638	165	Medium Sea Grey BS381C 637

## Westland Sea King HC.4

ZA298 'King of the Junglies', No. 846 Naval Air Squadron, Fleet Air Arm, Royal Navy, HMS Fearless, Operation 'Corporate', Falkland Islands, 1982.

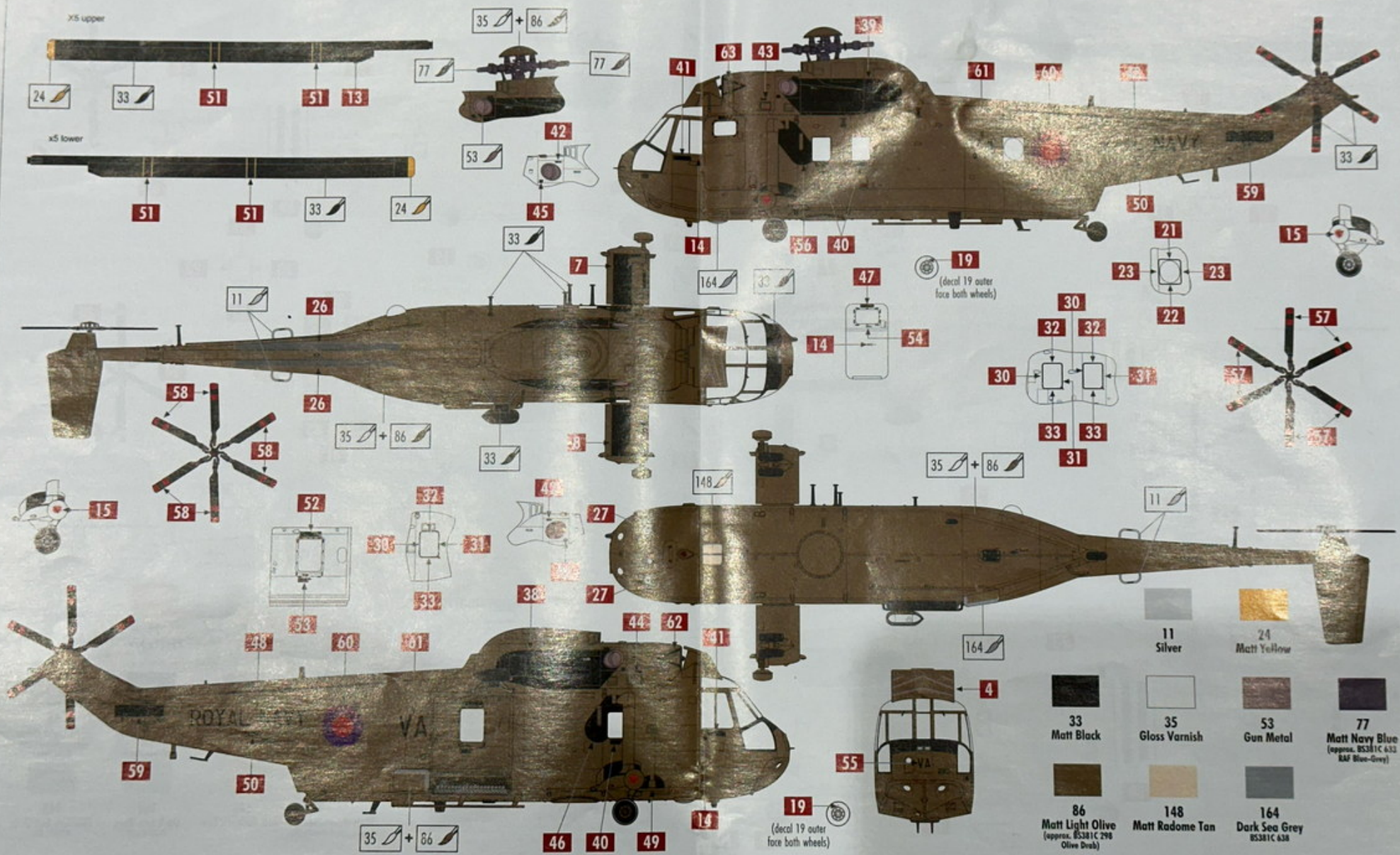

- |     |  |     |   |
|-----|--|-----|---|
| 11  | Silver   | 24  | Matt Yellow   |
| 33  | Matt Black   | 53  | Gun Metal   |
| 35  | Gloss Varnish  | 77  | Matt Navy Blue<br>(approx. BS381C 432<br>RAF Blue-Grey) |
| 86  | Matt Light Olive<br>(approx. BS381C 298<br>Olive Drab) | 148 | Matt Radome Tan   |
| 164 | Dark Sea Grey<br>BS381C 438                            |     |   |

# Westland Sea King HC.4

ZD480, No.845 Naval Air Squadron, Fleet Air Arm, Royal Navy, Croatia, 1995.

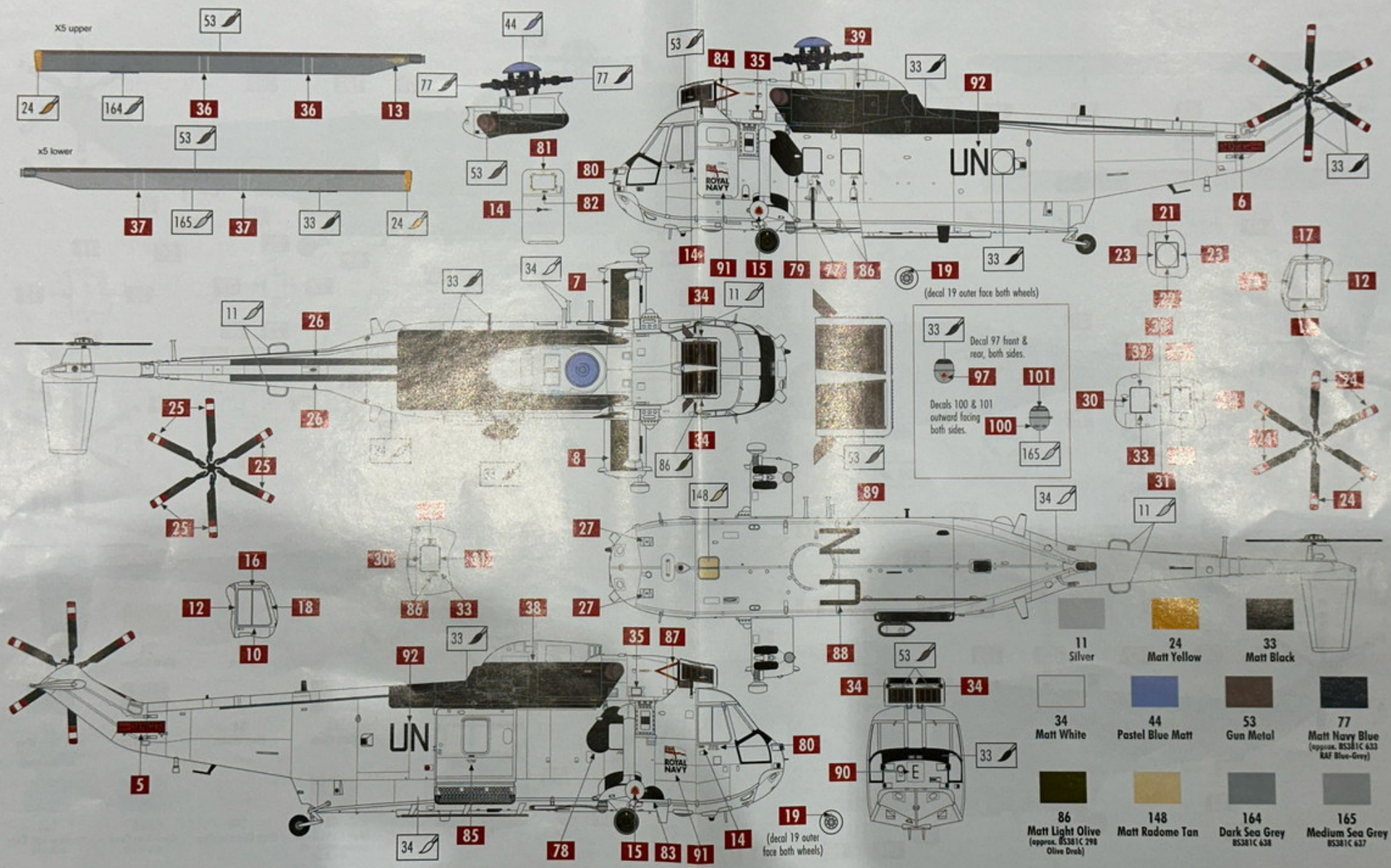

# Westland Sea King HC.4

ZF122, No.845 Naval Air Squadron, Fleet Air Arm, Royal Navy, Royal Naval Air Station Yeovilton, Somerset, 2013.

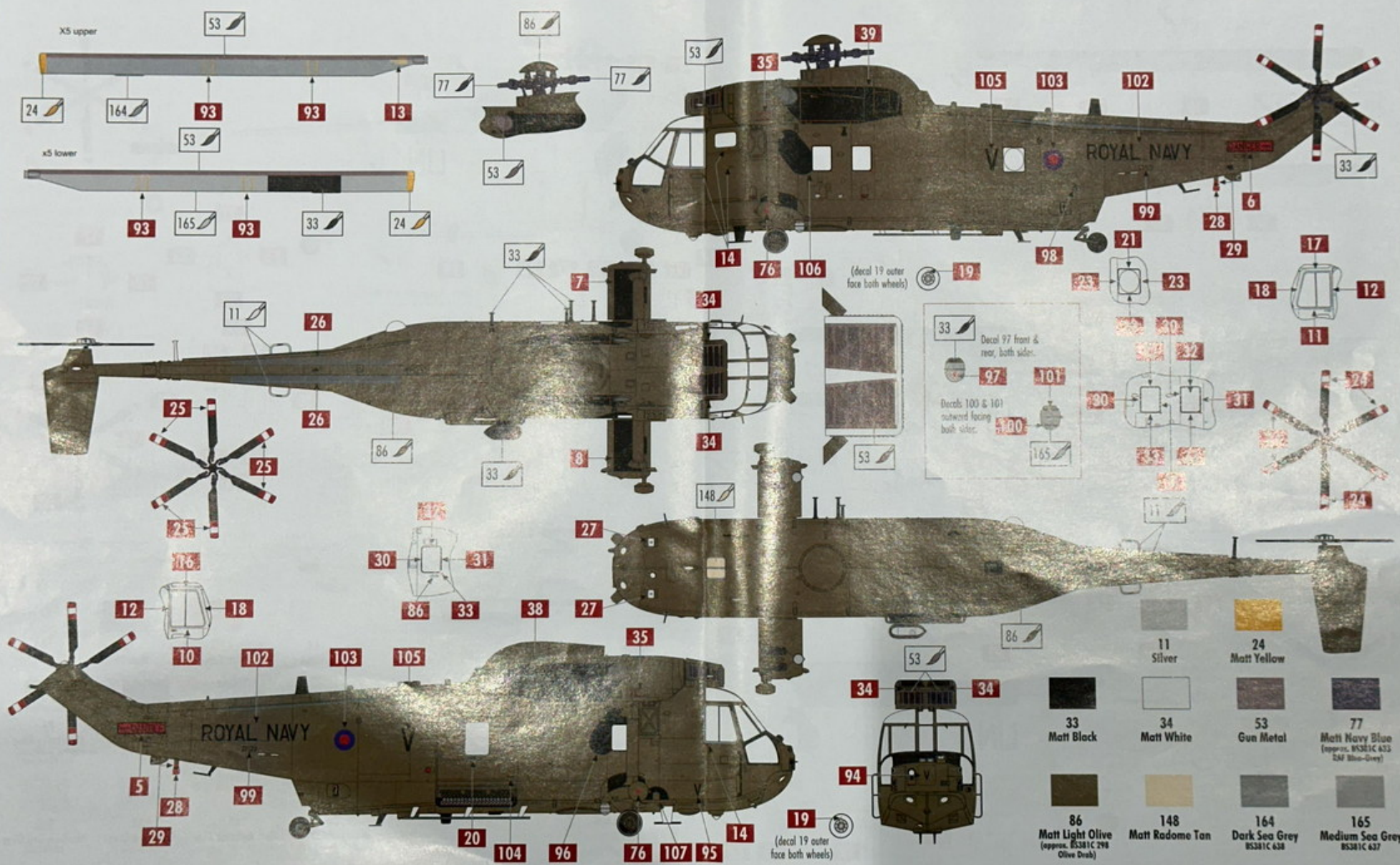

Decal 19 outer face both wheels

Decal 97 front & rear, both sides.

Decals 100 & 101 outward facing both sides.

11	Silver	24	Matt Yellow
33	Matt Black	53	Gun Metal
34	Matt White	77	Matt Navy Blue (approx. BS381C 633 RAF Blue-Grey)
86	Matt Light Olive (approx. BS381C 298 Olive Drab)	148	Matt Radome Tan
164	Dark Sea Grey BS381C 638	165	Medium Sea Grey BS381C 637