



BOEING C-97 STRATOFREIGHTER ANGEL OF DELIVERANCE

IN 1/144 SCALE

MINICRAFT
MODEL KITS
Legends in the making



The Berlin Airlift Historical Foundation acquired Boeing C-97G 52-2718 in 1996. A former KC-97, 52-2718 is one of only 2 remaining airworthy C-97's in the world. We plan to operate the "Angel of Deliverance" as a "flying museum, and classroom", in the same manner as we do with our Douglas C-54, "Spirit of Freedom". We plan to tell the story of the Cold War, from the Berlin Airlift of 1948 to the fall of the Berlin Wall in 1989.

These topics will be represented as part of a Timeline-oriented display throughout the fuselage of the aircraft. It will be augmented by artifacts, photographs, personal experiences, and it will be all housed in the hull of a true Cold Warrior, a former KC-97. The KC-97 helped the USAF maintain a "round the clock" presence in the air by becoming the first real air-to-air refueler. BOEING C-97G ANGEL OF DELIVERANCE sn 52-2718 Manufactured by

Boeing Aircraft Company, Seattle WA, as KC-97G and delivered to the USAF on April 27, 1954.

It had been operated as a cargo transport for humanitarian missions to South America and to carry fish in Alaska.

On April 22, 1996 it was purchased by the Berlin Airlift Historical Foundation.

Nov. 1997. It was flown from Moses Lake, Washington to Greybull, Wyoming for inspection and restoration.

Sep. 1999, Received FAA Approval of Inspection program achieved.

2000. Aircraft painted in colors of YC-97A 45-59595, the sole C-97 used in the Berlin Airlift.

July 2001, Flown from Greybull, Wyoming to Aberdeen South Dakota.

Nov. 2001 Flown from Aberdeen SD to Millville, NJ.

Minicraft Models. 1501 Commerce Drive, Wlgin, IL 60123 USA. e-mail:models@minicraftmodels.com



Cement
Coller
Kleben
Pegar
Incollare
Colar
Kleven



DO NOT Cement
Ne pas Coller
Nicht Kleben
No Pegar
Non Incollare
Nao Colar
Niet Kleven



Cut away
Couper
Scheiden
Cortar
Tagliere
Cortar
Snijden



Optional parts
Choix
Auswahlmoglichkeit
Eleccion
Scelta
Opaco
Keuze

1 FUSELAGE ASSEMBLY

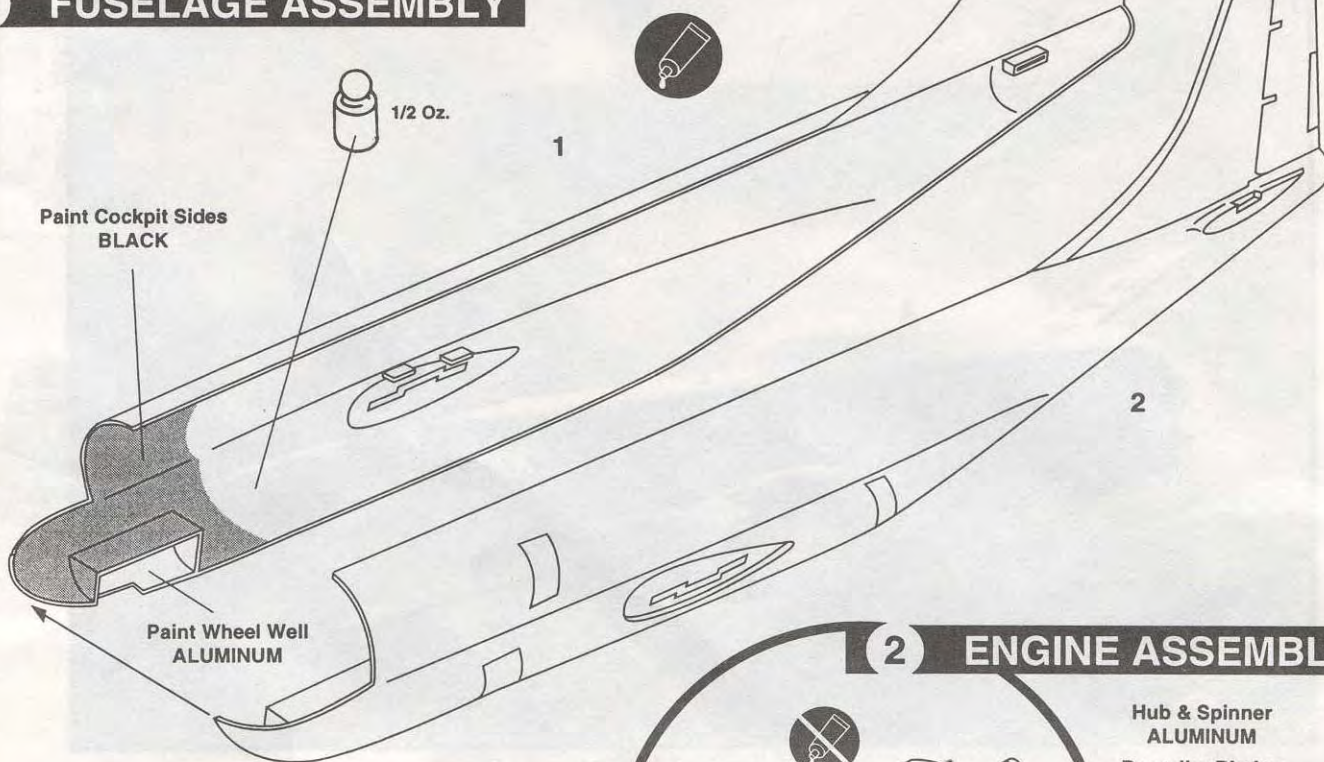

2 ENGINE ASSEMBLY

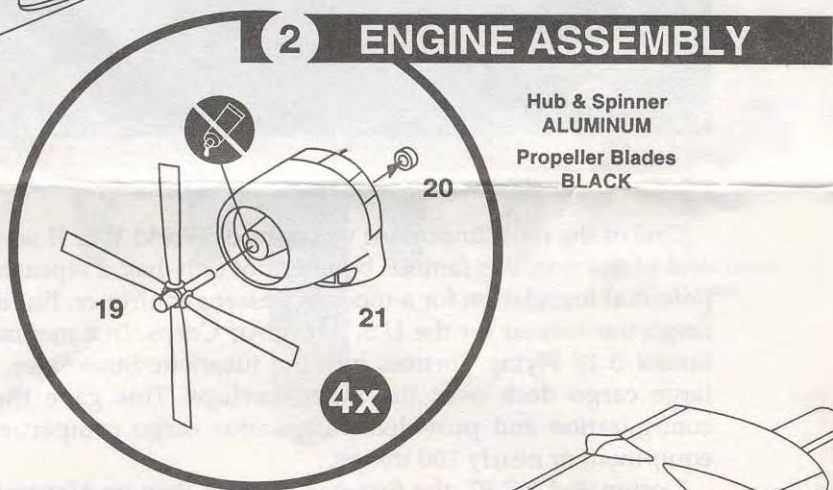

3 WING ASSEMBLY

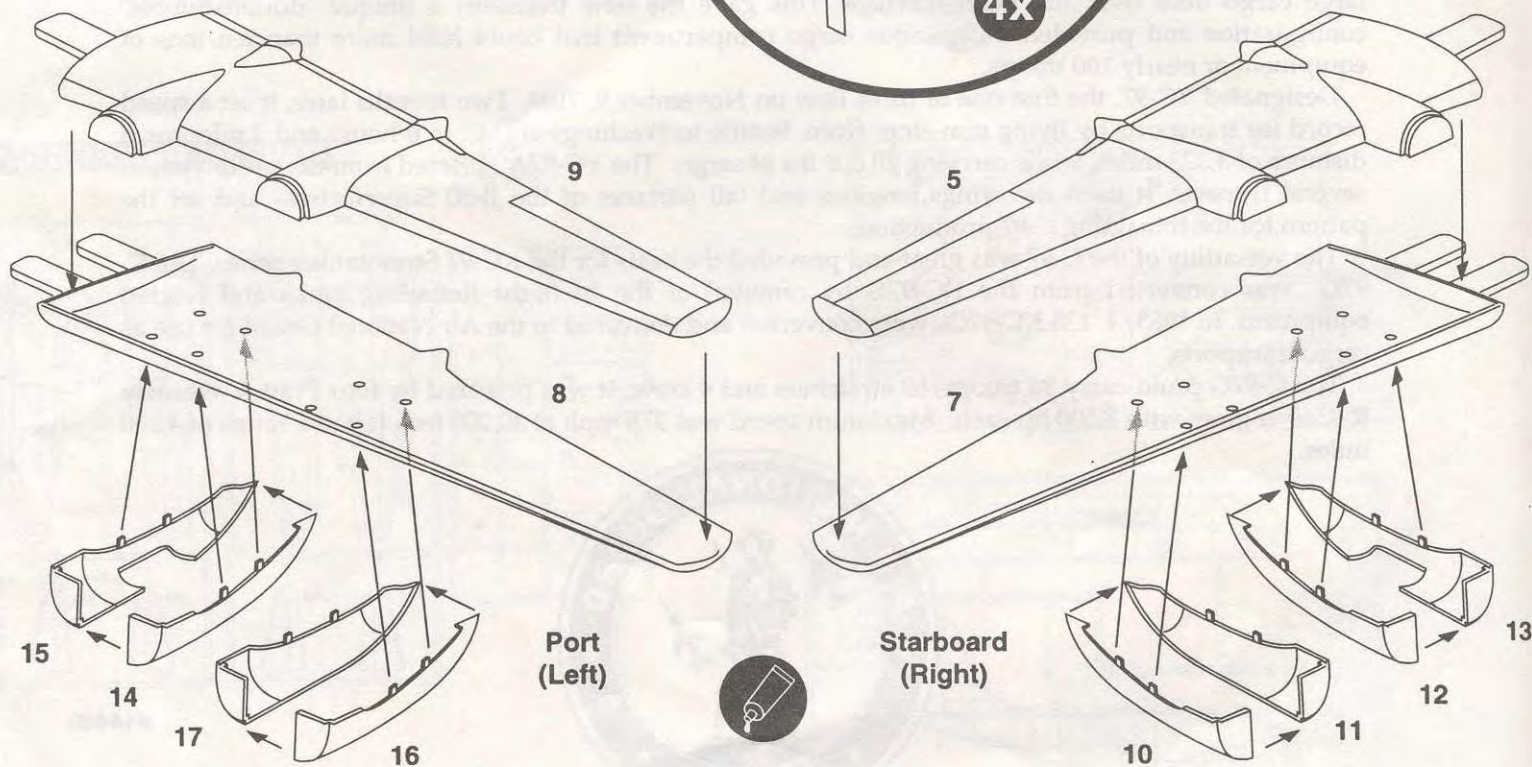

4 MAIN ASSEMBLY

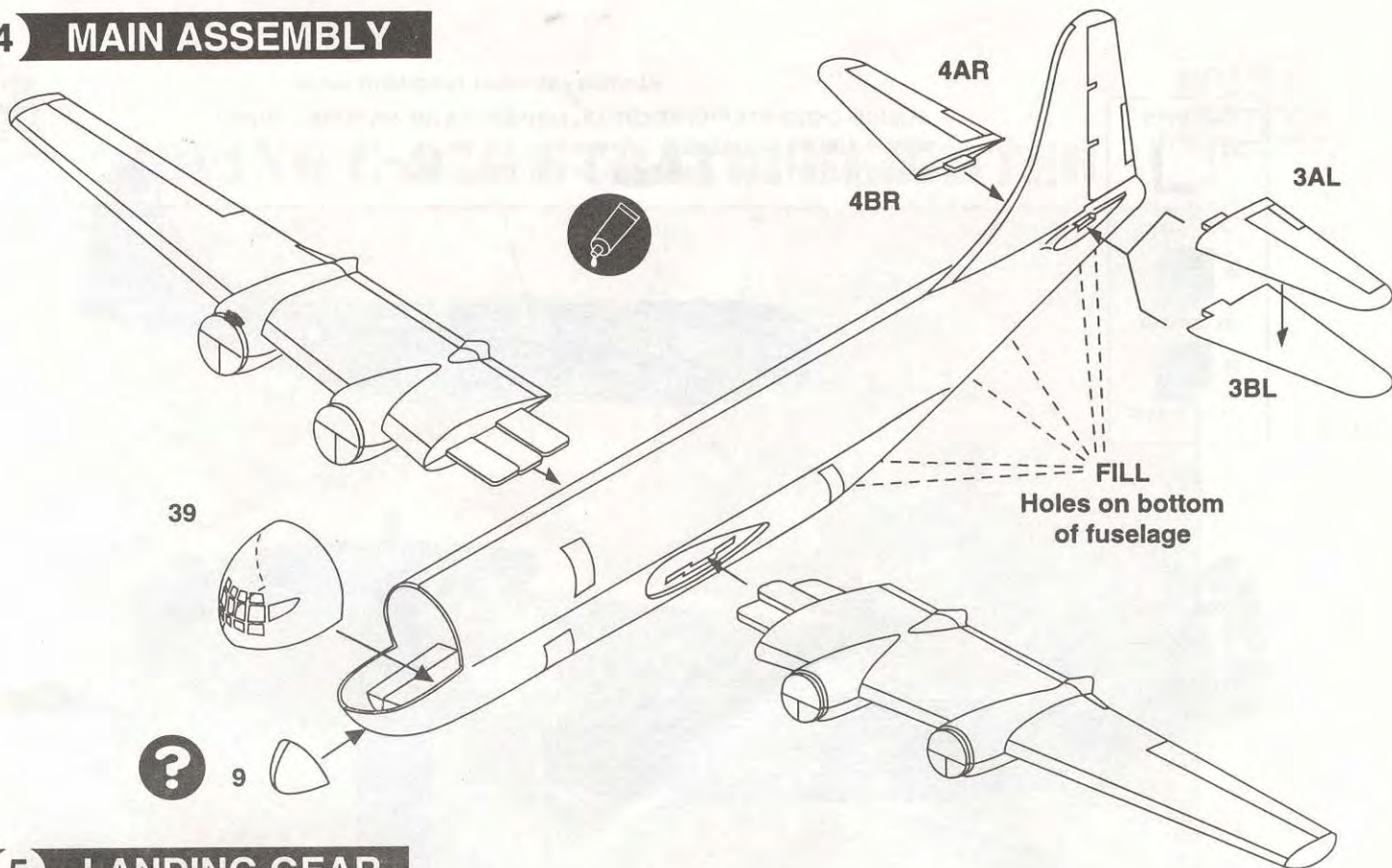

5 LANDING GEAR

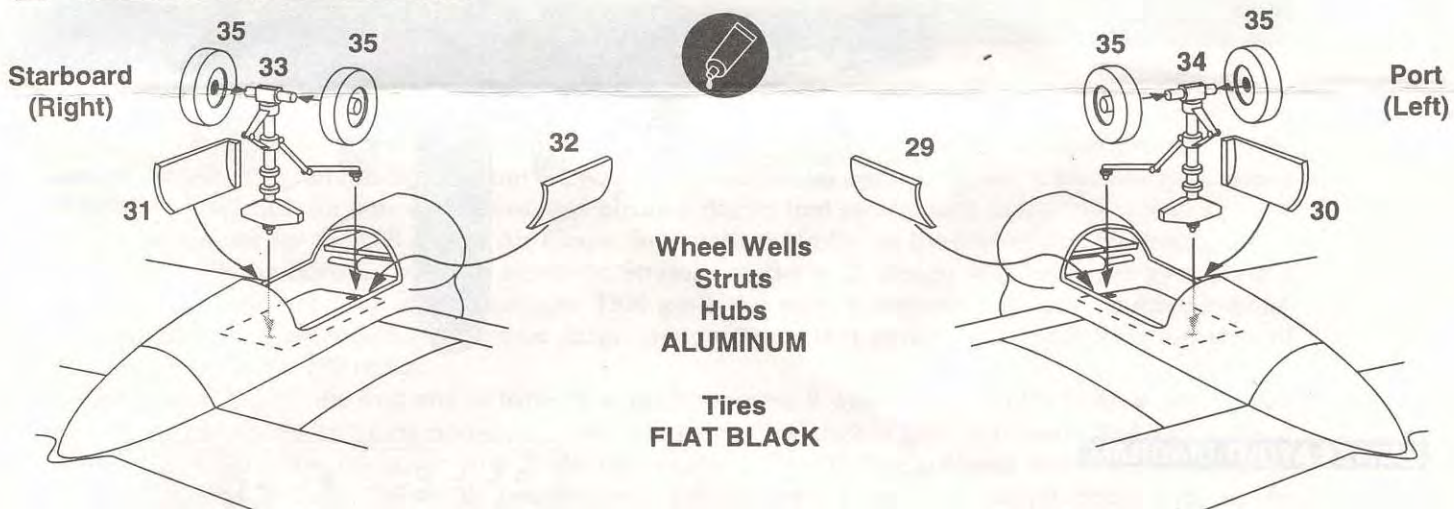

6 POWERPLANT ASSEMBLY

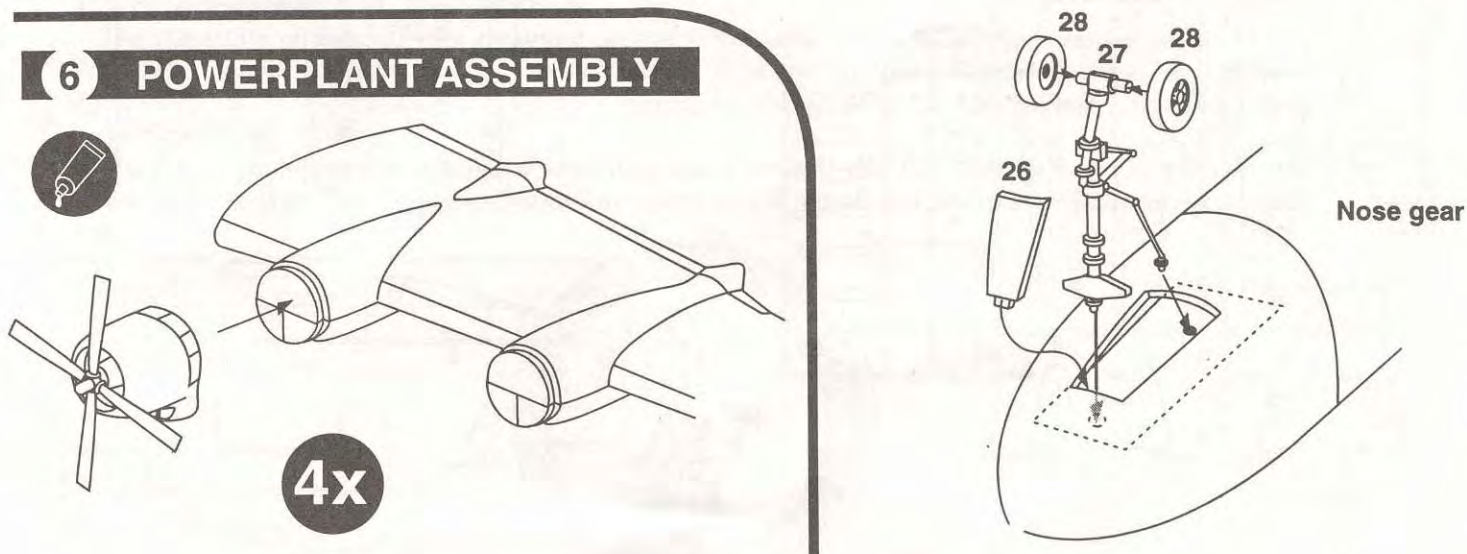



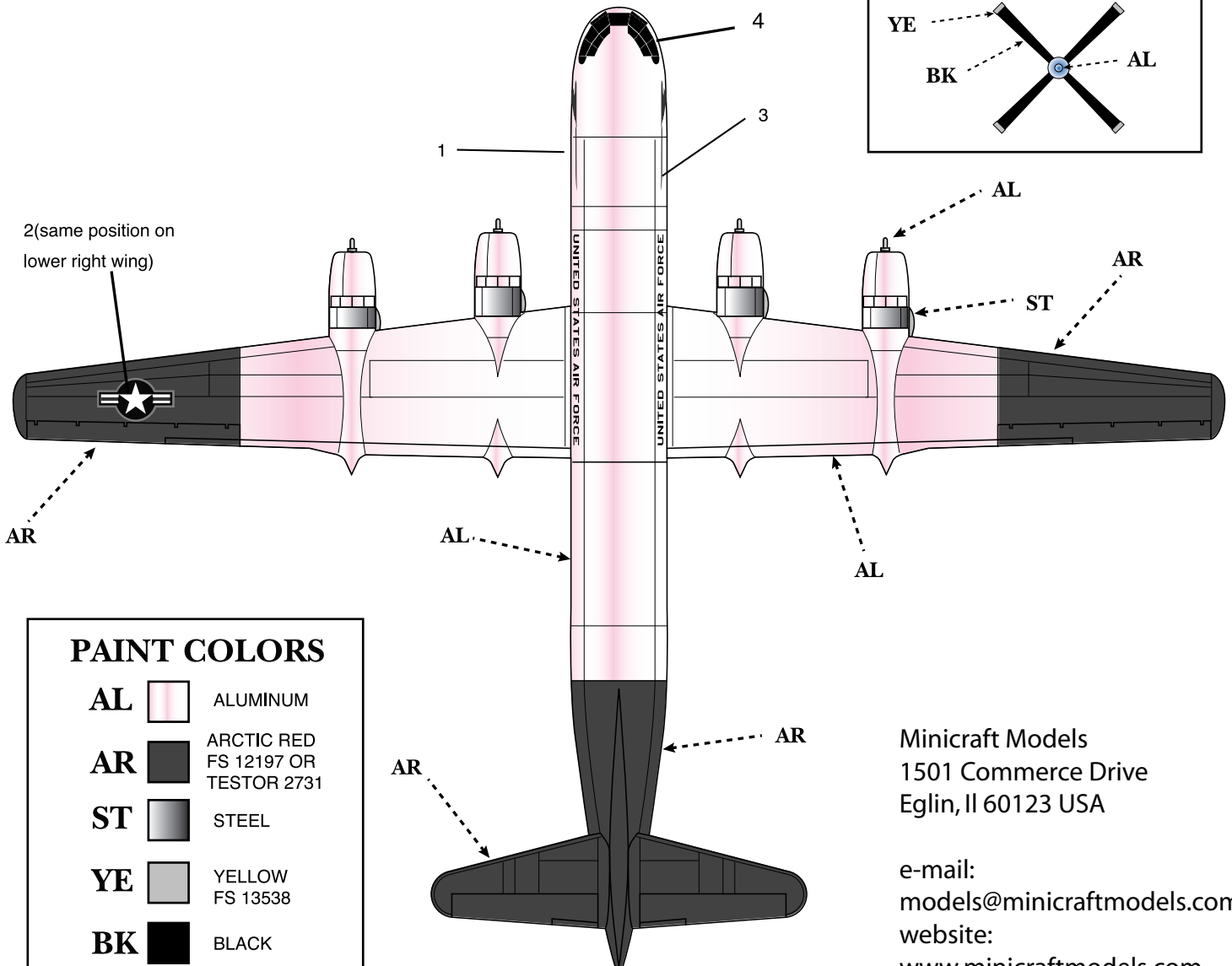
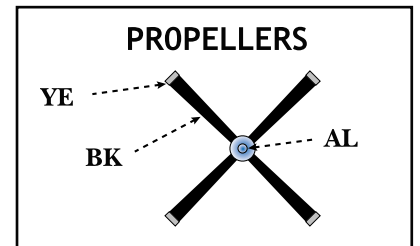
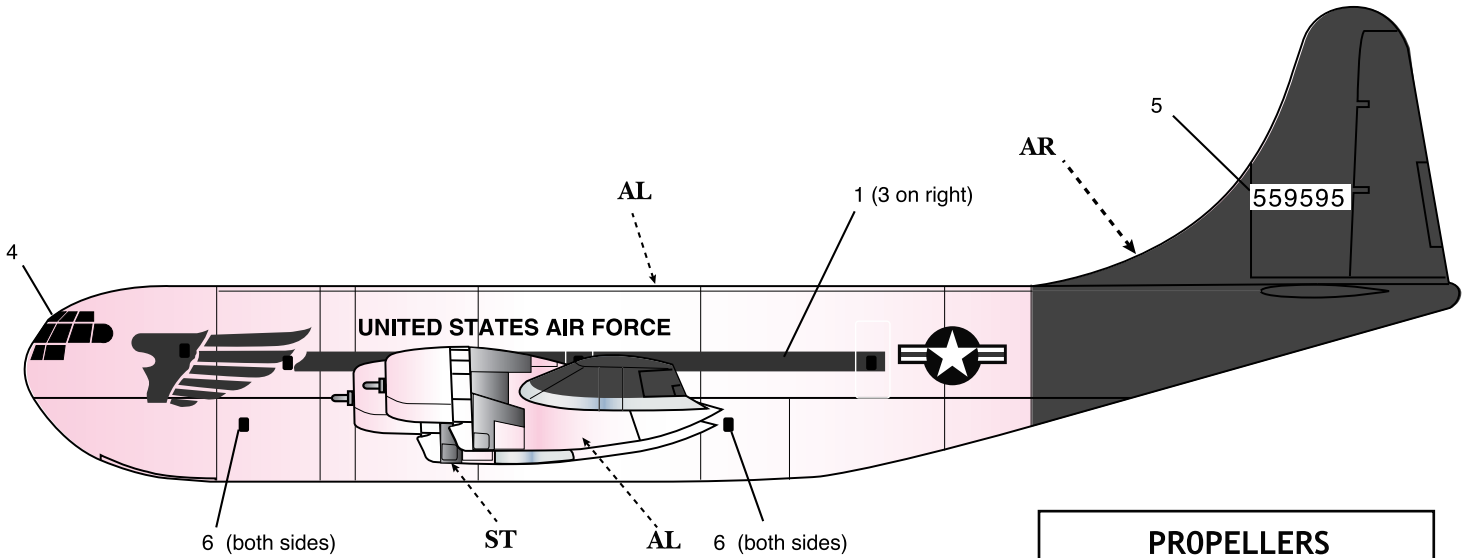

BOEING C-97 STRATOFREIGHTER ANGEL OF DELIVERANCE

**MINICRAFT
MODEL KITS**

Legends in the making



PAINT COLORS

AL		ALUMINUM
AR		ARCTIC RED FS 12197 OR TESTOR 2731
ST		STEEL
YE		YELLOW FS 13538
BK		BLACK

Minicraft Models
1501 Commerce Drive
Eglin, IL 60123 USA

e-mail:
models@minicraftmodels.com
website:
www.minicraftmodels.com