

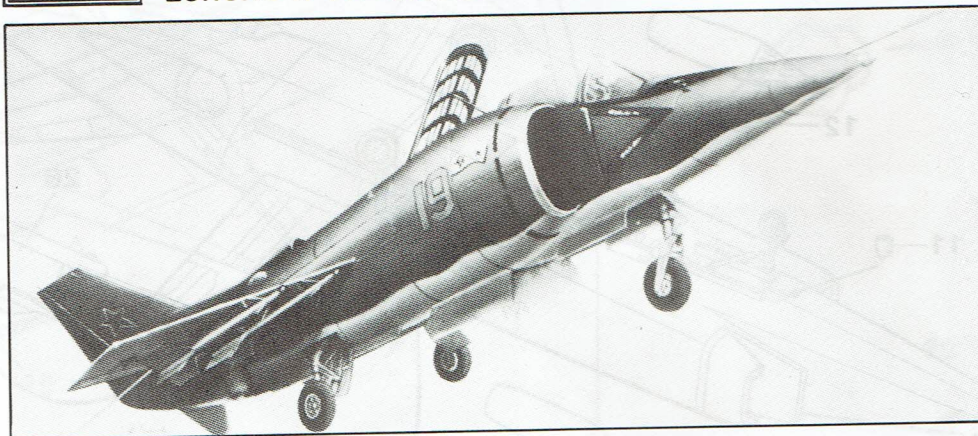

YAK38 "Forger A" ATTACK AIRCRAFT AVION D'ATTAQUE

Echelle 1/72 SCALE



SPECIFICATIONS

Type: Light VTOL Shipboard Strike Fighter

Powerplant: One 16500 lb. class lift/cruise engine and two 5500 lb. Kolesov Lift Jets

Performance: Maximum speed at 36000 ft. 800 MPH or Mach 1.2 at sea level 650 MPH or Mach 0.85; service ceiling 46000 ft.; combat radius 150 miles

Dimensions: Span 23 ft., length 49 ft. 2 in., 10 ft. 6 in., wing area 170 sq. ft.

Armament: Four external pylons for UIP to 2200 lb. of stores including AA-8 "APHID" air to air missiles and gun pods

Operator: USSR/UDSSR

The YAK-38 is positioned on the modern Soviet Kiew-class Nuclear Carriers and prepared for vertical take off in a very short time to defend the ships against other attack-aircraft or Lockheed P-3's with their harpoon missiles. It can be compared with the AV-8 Barrier of the U.S. Navy.

SPECIFICATIONS:

Type: Chasseur léger ATV de navire

Performance: Vitesse Maximale a 36000 pi — 800 mi/h ou Mach 1.2 Niveau de la mer — 650 mi/h ou Mach 0.85; Plafond: 46000 pi; portee de combat 150 milles

Dimensions: Envergure 23 pi, longueur 49 pi 2 po, 10 pi 6 po, surface portante 170 pi ca.

Armement: Quatre pilons extérieurs pour 2200 lb d'armes dont des missiles "APHID" AA-8 air/air et des nacelles de canon

Utilisateurs: URSS/UDRSS

Le YAK-38 est en position sur les porte-avions modernes sovietiques de classe kiew et se prepare rapidement au decollage vertical pour proteger les navires contre les attaques aeriennes ou des missiles harpons des lockheed P-3. Il se compare au harrier AV-8 de la U.S. Navy.

TYPENBESCHREIBUNG

Typ: Leichter schiffsgestutzter VTOL abfangjager

Triebwerke: Ein 7500 kg class lift/cruise engine triebwerk und zwei 2500 kg kolesov lift jets.

Leistungen: Höchstgeschwindigkeit in 11000 m 1280 km/h oder Mach 1.2, in meereshöhe 1050 km/h oder Mach 0.85; dienstgipfelhöhe 14000 m; aktionsradius: 250 km.

Abmessungen: Spannweite 7.00 m, lange 15.00 m, höhe 3.20 m, flugelfläche 15,8 m²

Bewaffnung: Vier außenpylons für bis zu 1000 kg zuladung (z.b. AA-8 "APHID" luft-luft raketen bzw. kanonenbehälter)

Betreiber: USSR/UDSSR

Die YAK-38 ist derzeit auf den sovietischen nuklear-trägern der kiew-klasse stationiert und ist für äußerst schnelle senkrecht-starts zur abwehr von feindlichen jagern ausgelegt. Im prinzip kann sie als gegenstück der amerikanischen AV-8 harrier angesehen werden.

READ THIS BEFORE YOU BEGIN:

- Study the assembly drawings.
- Each plastic part is identified by a number.
- Check the fit of each piece before cementing in place.
- Do not use too much cement to join parts.
- Model may be painted to match photos on box.

LIRE CECI AVANT DE COMMENCER:

- Étudier les dessins d'assemblage.
- Chaque pièce de plastique est numérotée.
- S'assurer que la pièce convient avant de la coller.
- Ne pas utiliser trop de colle.
- On peut peindre le modèle pour l'apparier aux photos de la boîte.

VOR ZUSAMMENBAU BITTE SUFMERKSAM LASAN

- Studiere die bauanleitung.
- Jedes Plastikteil ist gakenzeichnet burch sine nummer.
- Prüfe vor dem kleban ob die teile zusammenpassen.
- Benutze nicht zuviel kleber.
- Die bemalung des modells ist auf dem deckelbild gazeigt.

1 PILOT SEAT ASSEMBLY ASSEMBLAGE DE PLACE ET PILOTE

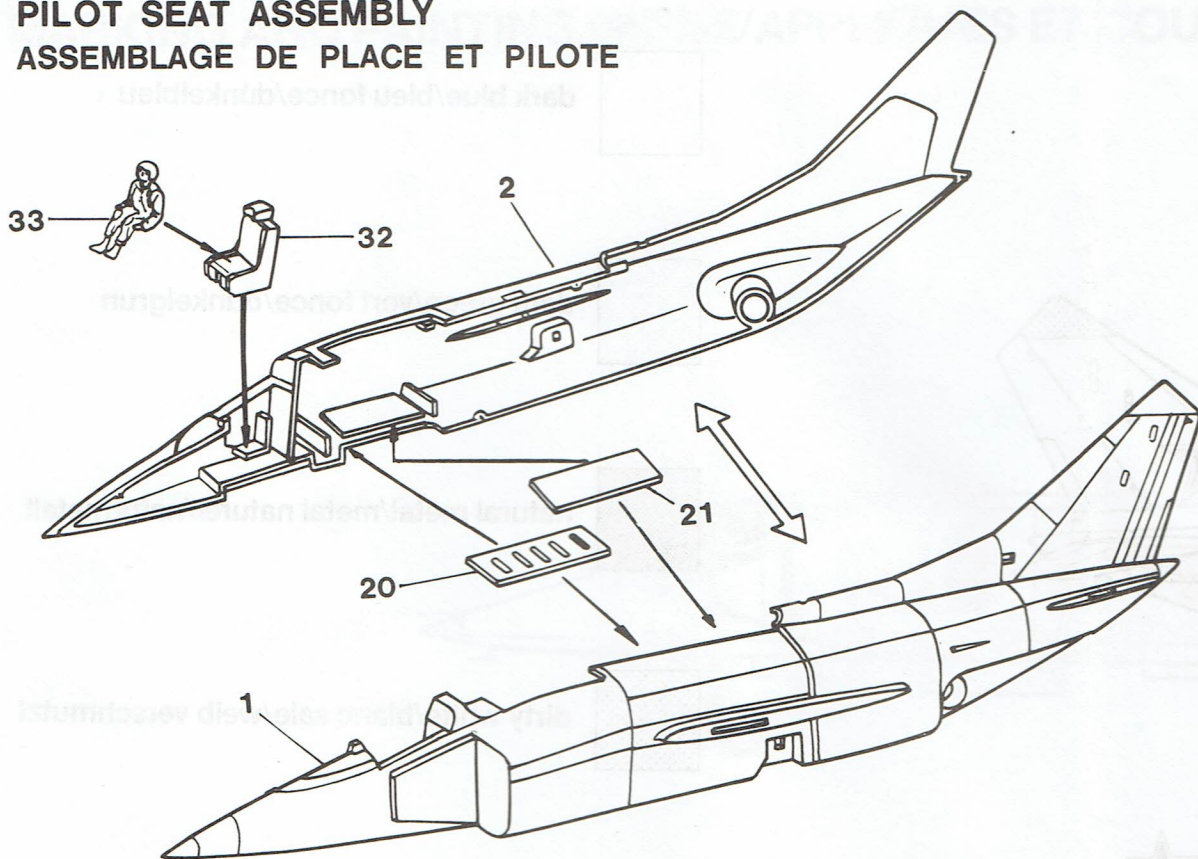

2 WING ASSEMBLY ASSEMBLAGE DES AILES

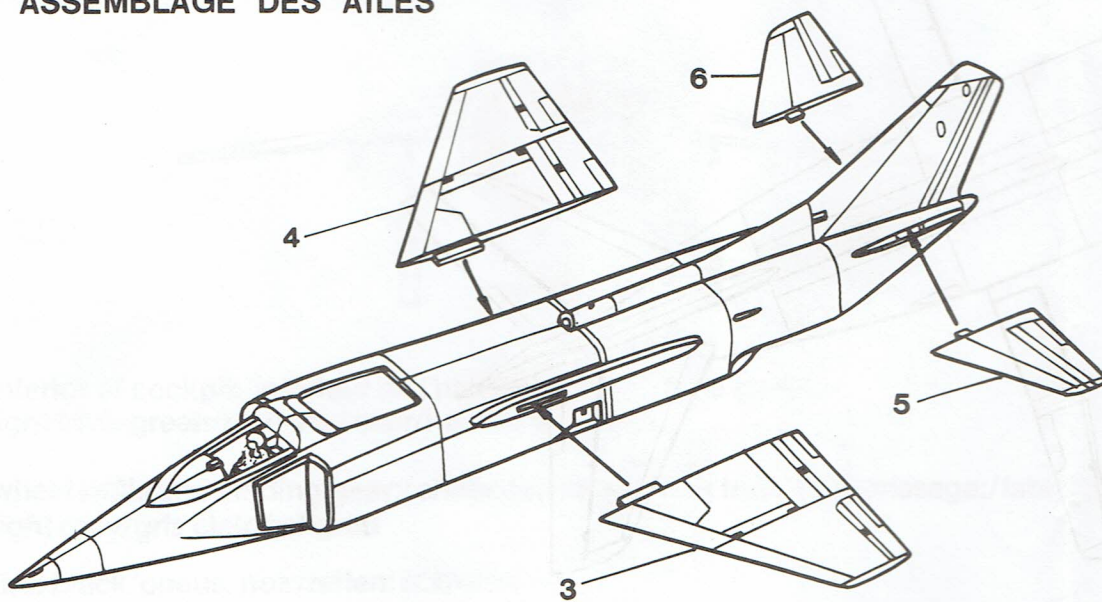

3 AIR ASSE

4 PART ASSE

3 AIR INTAKE ASSEMBLY ASSEMBLAGE DE CONDUIT L'AIR

5

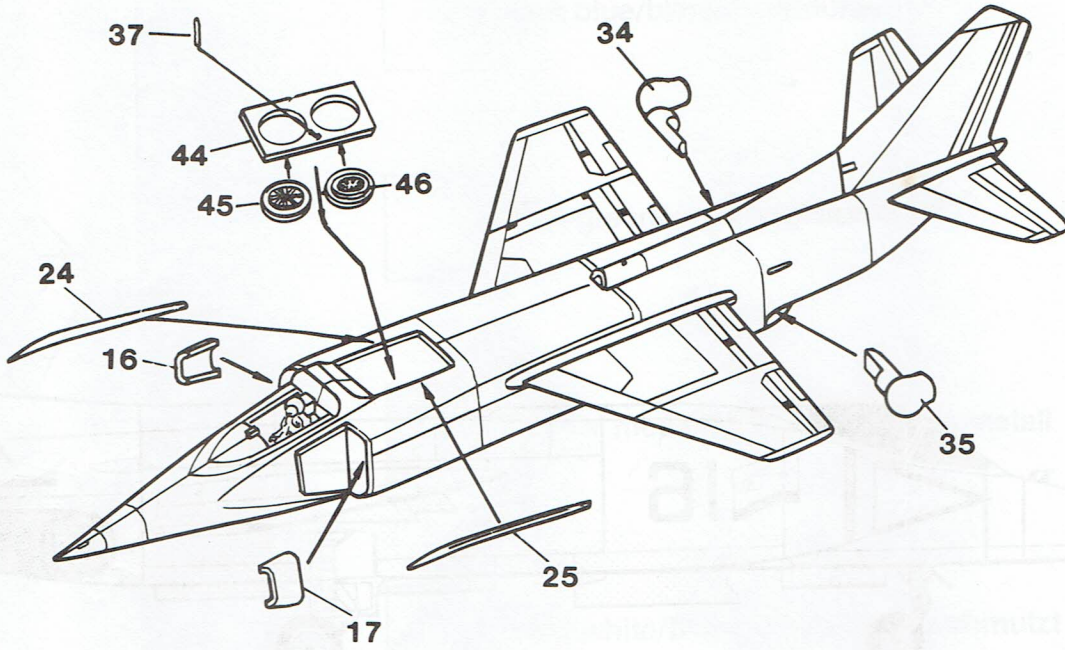

4 PARTS ASSEMBLY ASSEMBLAGE DES PIÈCES

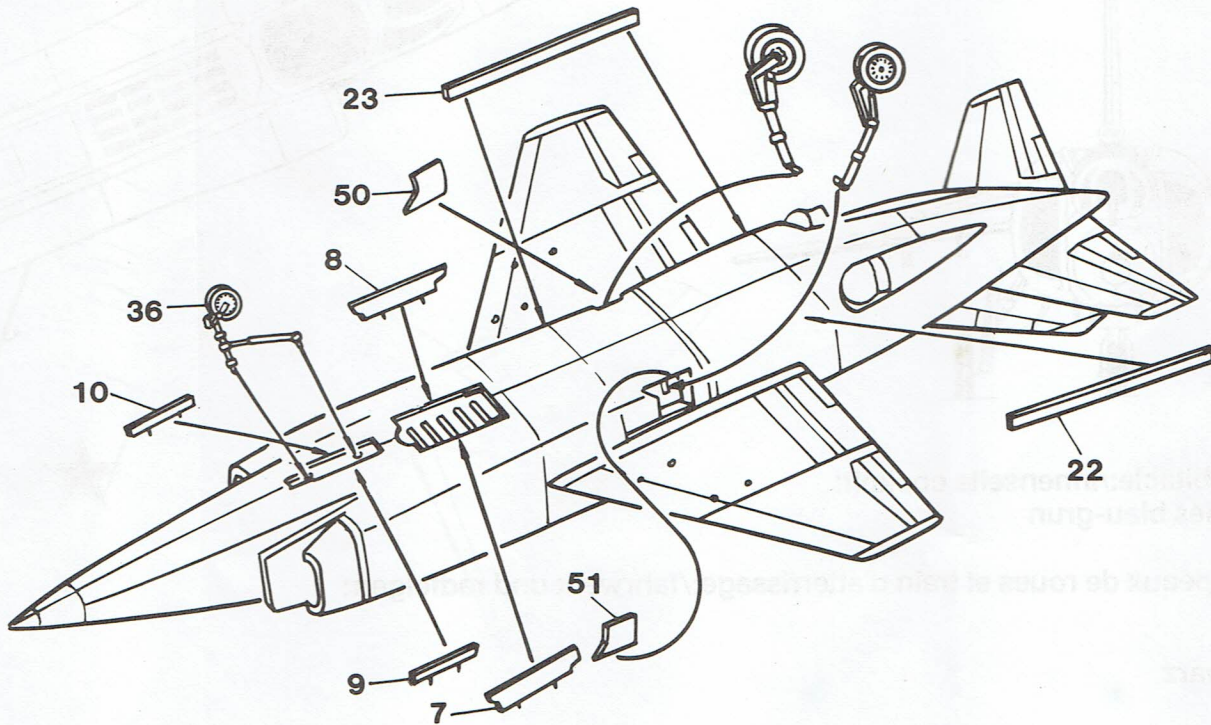

5 BOMB ASSEMBLY ASSEMBLAGE DES BOMBES

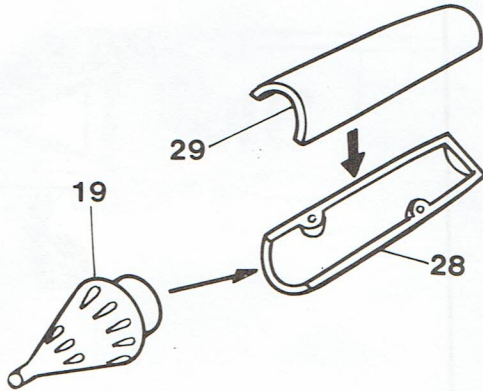
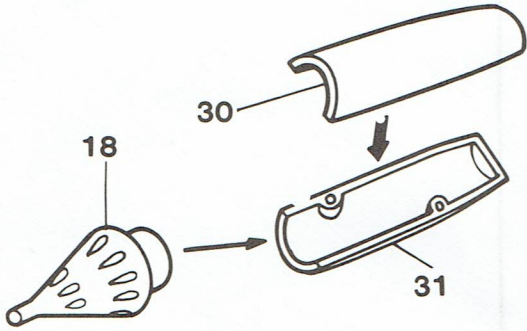

7 ARMAMENT ARMEMENT

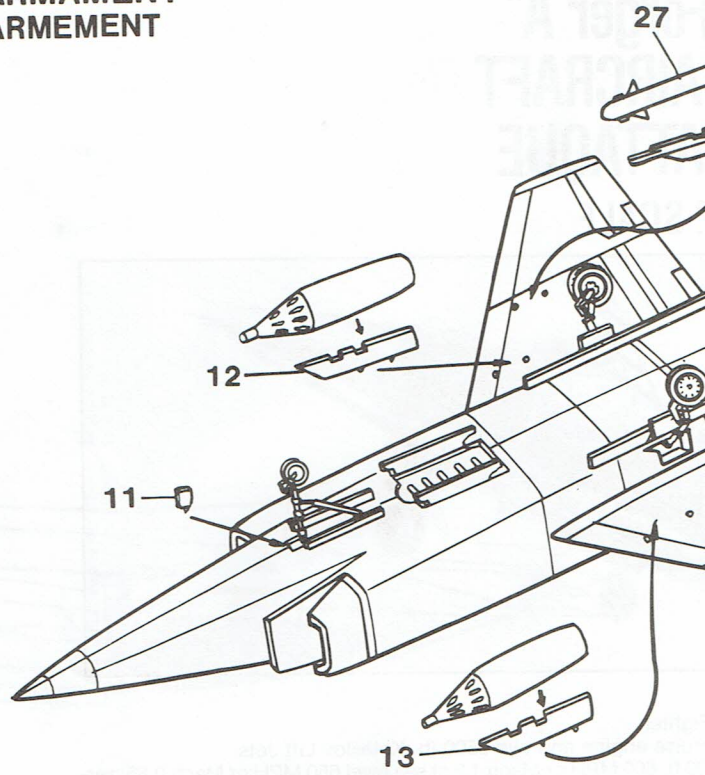

6 LANDING GEAR ASSEMBLY TRAIN D'ATERRISSAGE

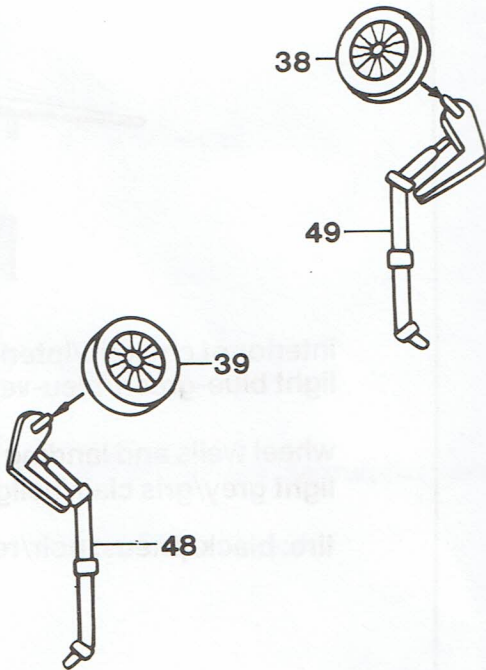

8 CANOPY ASSEMBLY ASSEMBLAGE D'VERRIERE

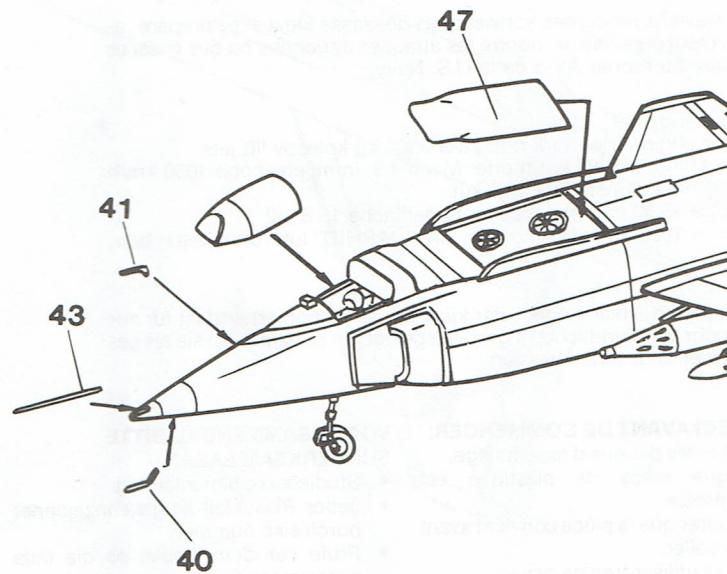

7 ARMAMENT ARMEMENT

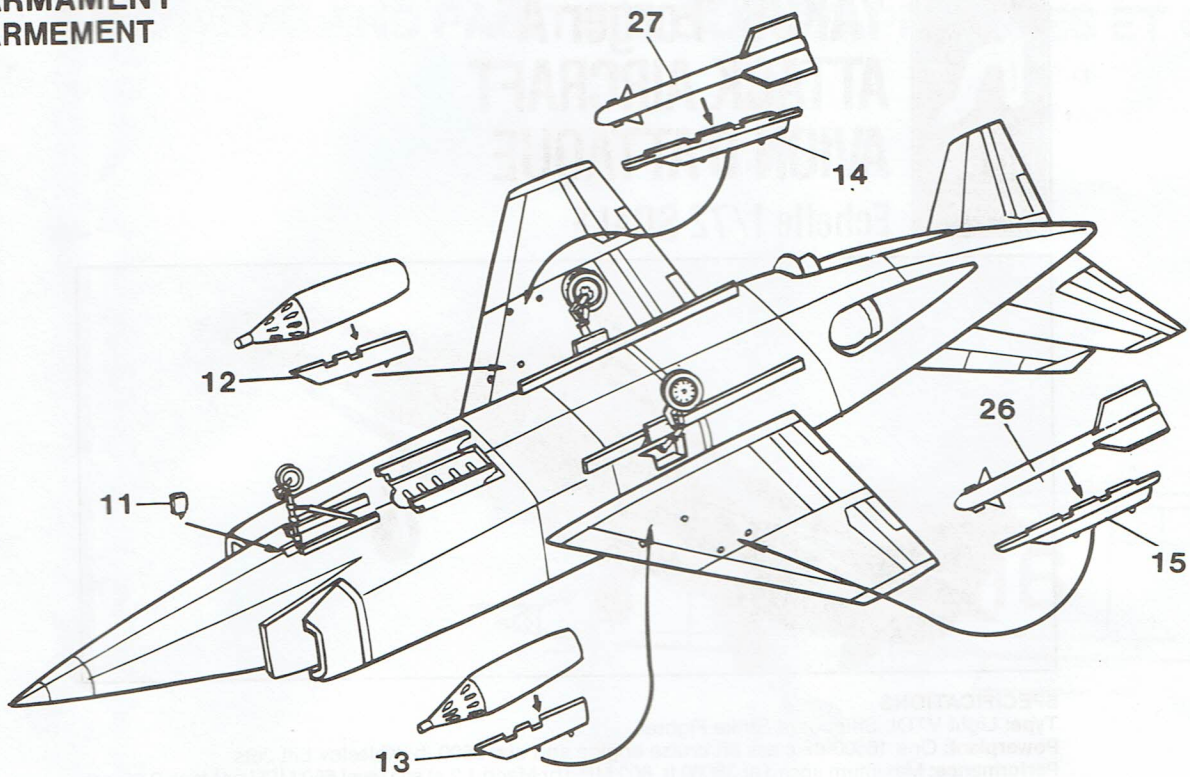

8 CANOPY ASSEMBLY ASSEMBLAGE D'ARRIERE

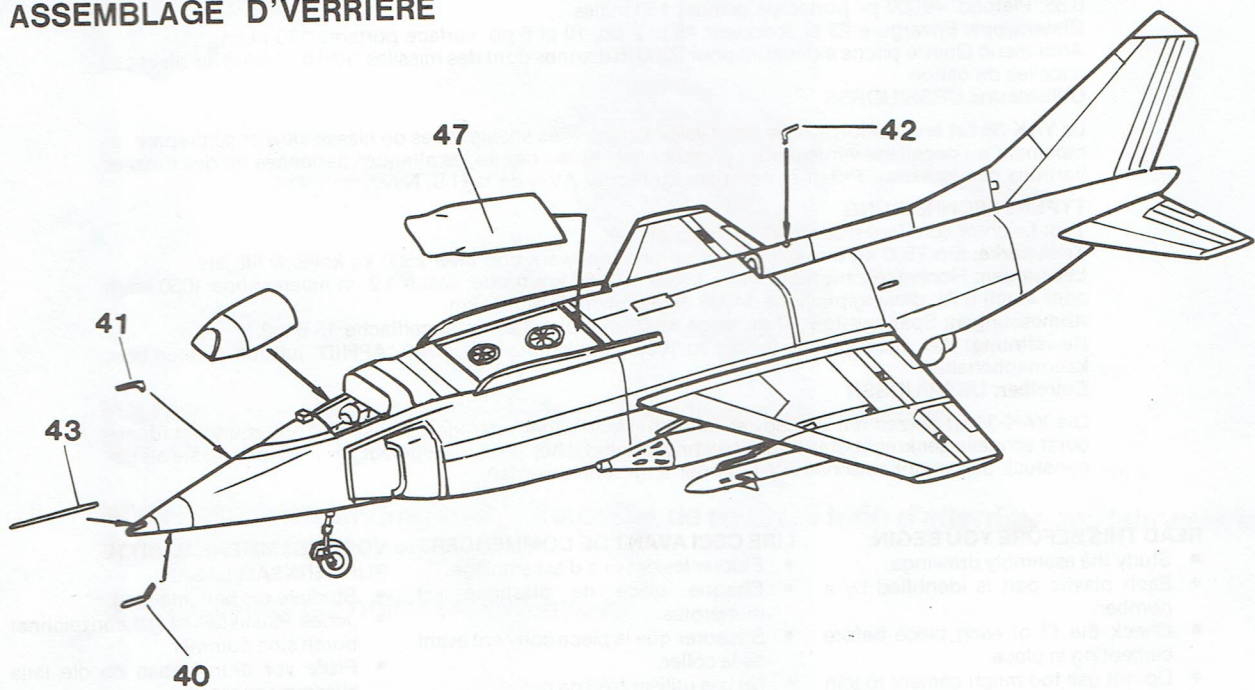

EUR



elgen:

MARKING AND PAINTING GUIDE/APPLIQUES ET COULEUR

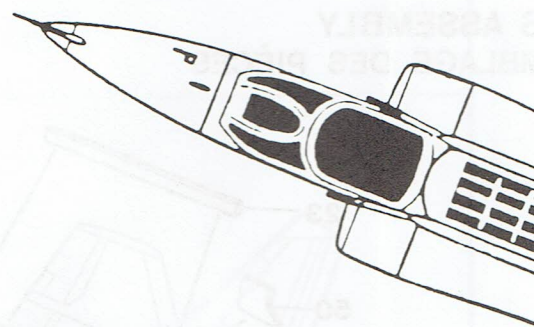
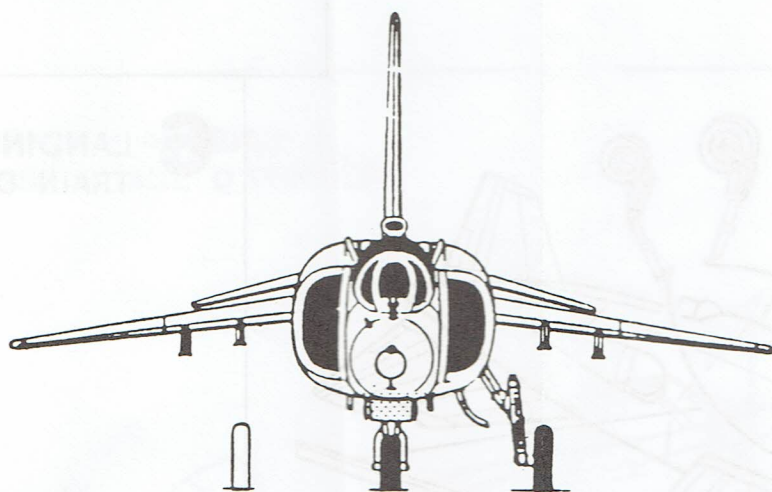
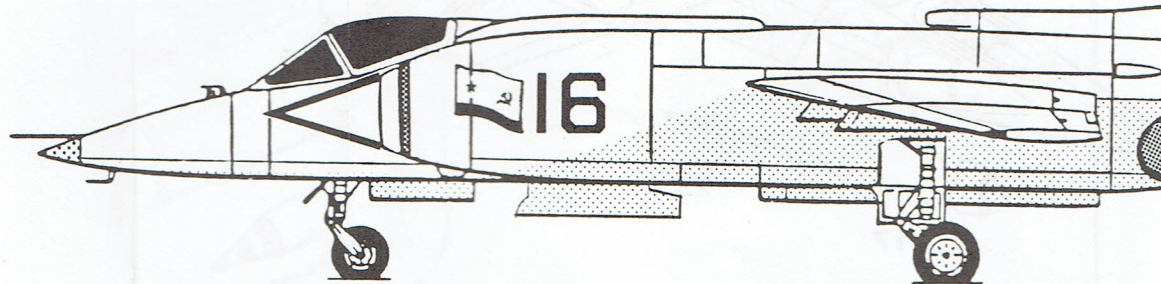

interior of cockpit:/interieur de l'habitacle:/innenseite cockpit:
light blue-green/bleu-vert clair/helles blau-grun

wheel wells and landing gear:/chapeaux de roues et train d'atterrissage:/fahrwerk und radfelgen:
light grey/gris clair/hellgrau

tire: black/pneus: noir/reifen: schwarz



dark blue/bleu fonce/dunkelblau

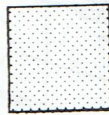

dark green/vert fonce/dunkelgrun

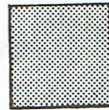

natural metal/metal naturel/naturmetall

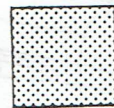

dirty white/blanc sale/weib verschmutzt

