



Carefully read instruction sheet before assembling. When you use glue or paint, do not use near open flame and use in well ventilated room. Keep out of reach of small children. Children must not be allowed to suck any part, or pull vinyl bag over the head.



Před započatím stavby si pečlivě prostudujte stavební návod. Při používání barev a lepidel pracujte v dobře větrané místnosti. Lepidla ani barvy nepoužívejte v blízkosti otevřeného ohně. Model není určen malým dětem, mohlo by dojít k požití drobných dílů.

INSTRUCTION SIGNS * INSTR. SYMBOLS * INSTRUKTION SINNBILDEN * SYMBOLES * 記号の説明



OPTIONAL
VOLBA



BEND
OHNOUT



SAND
BROUSIT



OPEN HOLE
VYVRTAT OTVOR



SYMETRICAL ASSEMBLY
SYMETRICKÁ MONTÁŽ



REMOVE
ODRÍZNOUT



REVERSE SIDE
OTOČIT



APPLY EDUARD MASK
AND PAINT
POUŽÍT EDUARD MASK
NABARVIT

PARTS



DÍLY



TEILE



PIÈCES



部品

PLASTIC PARTS

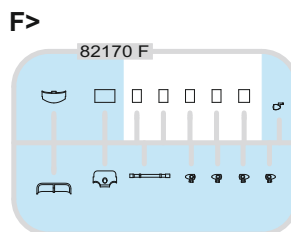
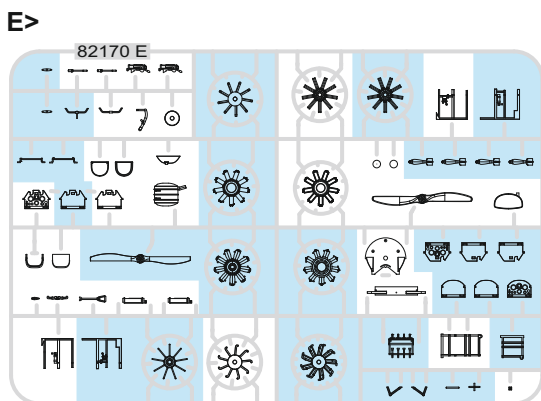
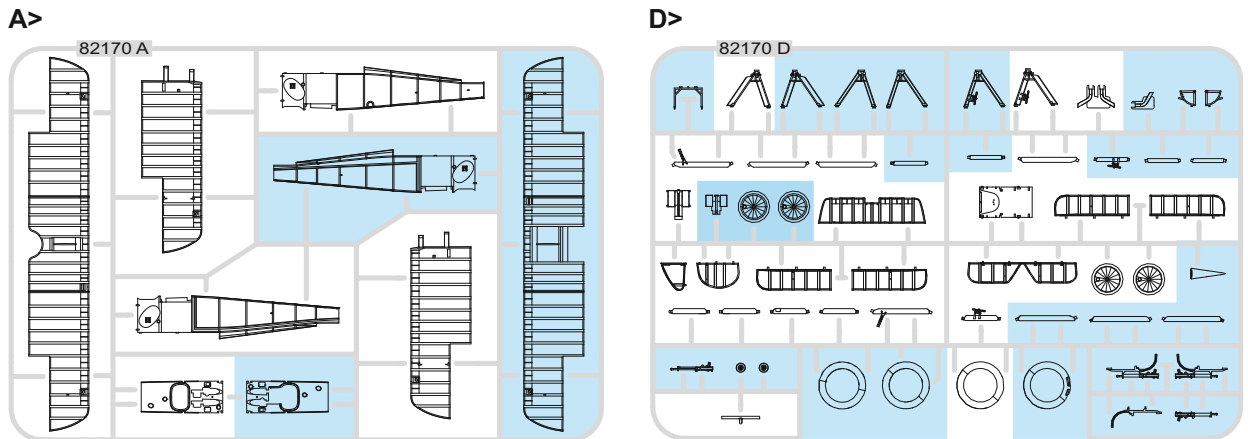

PE - PHOTO ETCHED DETAIL PARTS

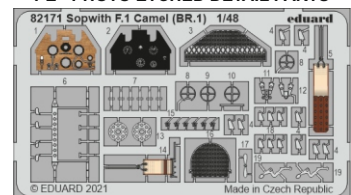

-Parts not for use. -Teile werden nicht verwendet. -Pièces à ne pas utiliser. -Tyto díly nepoužívejte při stavbě. - 使用しない部品

COLOURS



BARVY



FARBEN



PEINTURE



色

GSI Creos (GUNZE)		MISSION MODELS	
AQUEOUS	Mr.COLOR	PAINTS	
H8	C8		SILVER
H11	C62	MMP-001	FLAT WHITE
H12	C33	MMP-047	FLAT BLACK
H25	C34		SKY BLUE
H37	C43		WOOD BROWN
H51	C11	MMP-063	LIGHT GULL GRAY
H53	C13		NEUTRAL GRAY
H78	C38		OLIVE GREEN

GSI Creos (GUNZE)		MISSION MODELS	
AQUEOUS	Mr.COLOR	PAINTS	
H85	C45		SAIL COLOR
H318	C318	MMP-070	RADOME
	C19		SANDY BROWN
Mr.METAL COLOR		METALLICS	
MC214		MMM-001	DARK IRON
MC215		MMM-004	COPPER
MC218		MMM-003	ALUMINIUM

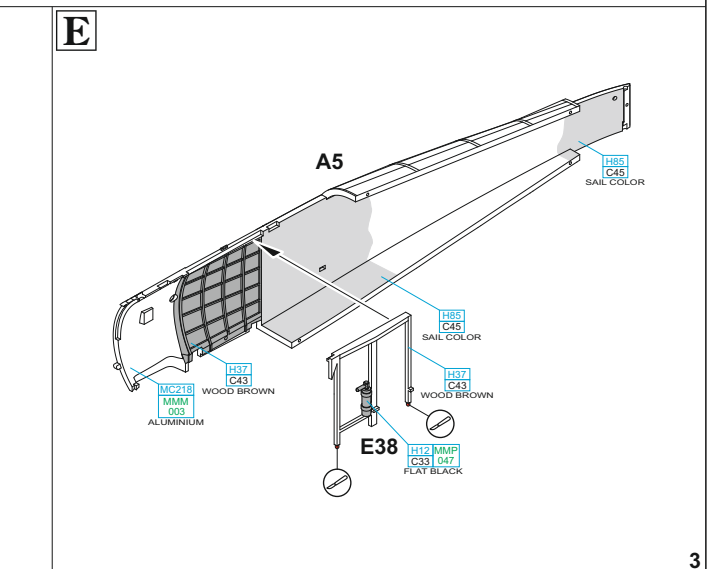
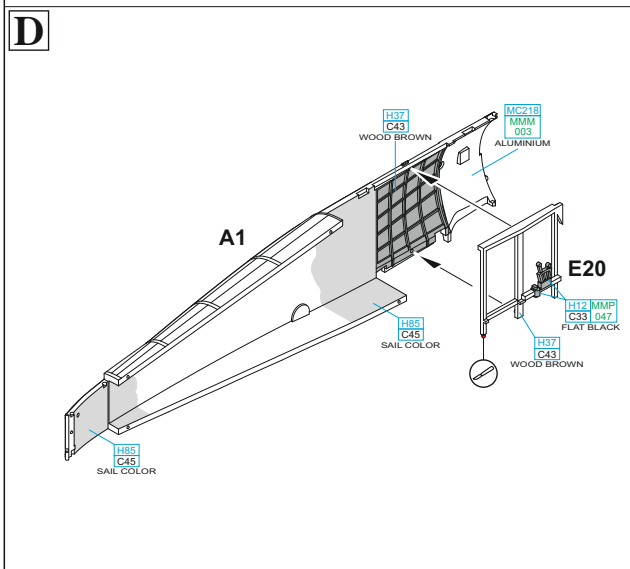
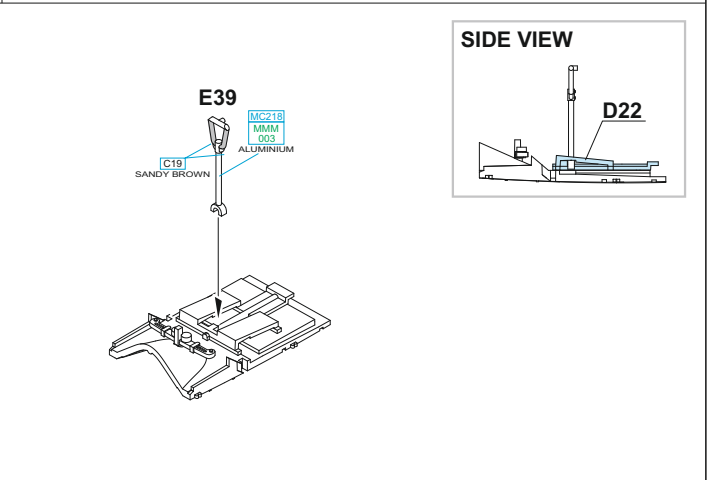
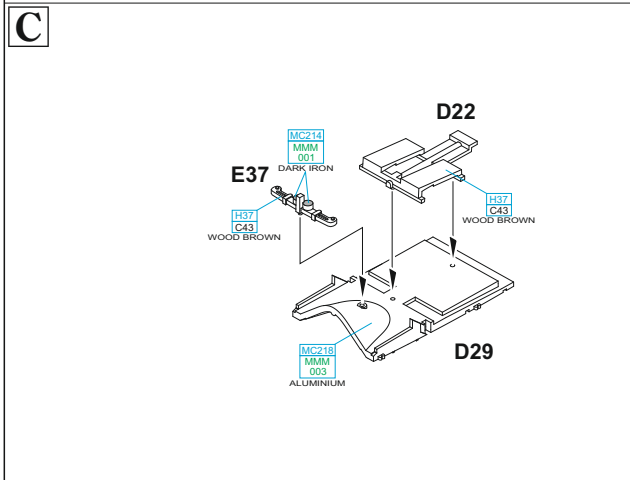
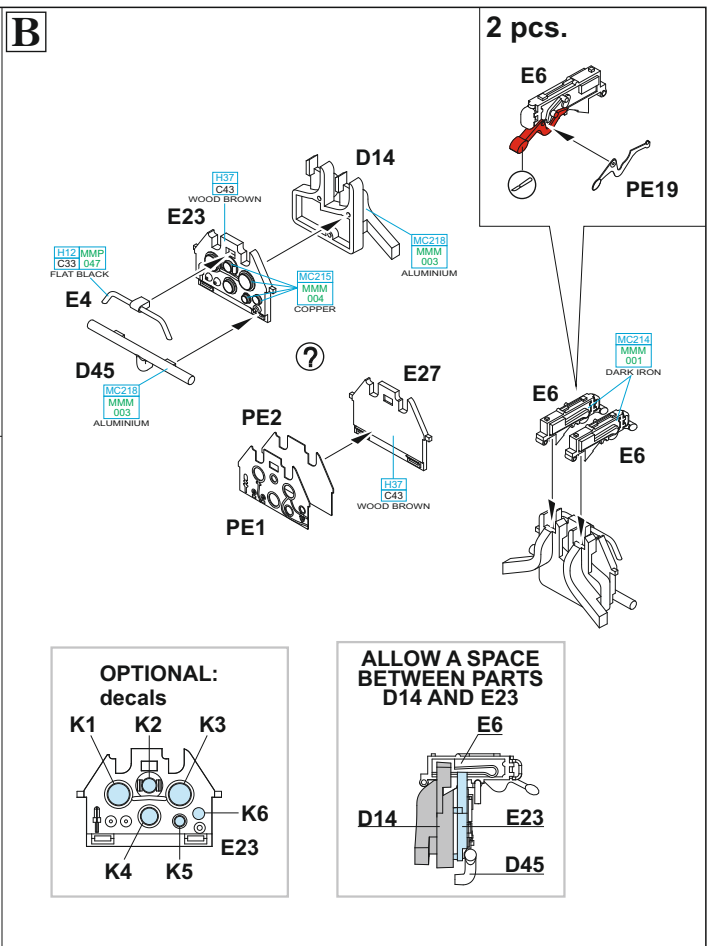
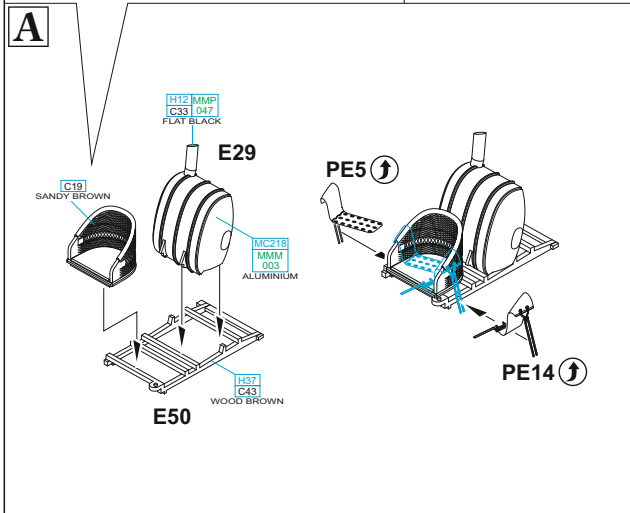
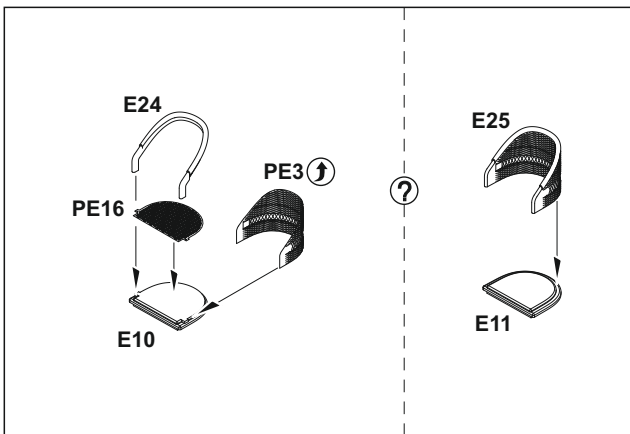

SIDE VIEW

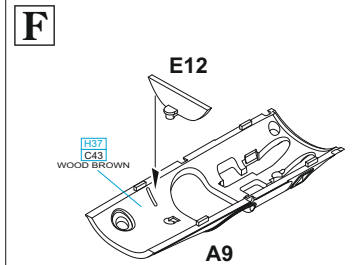
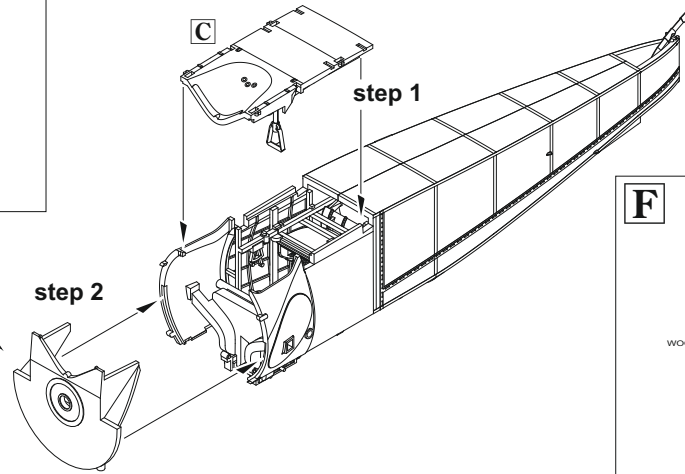
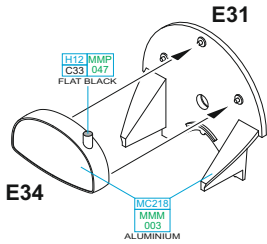
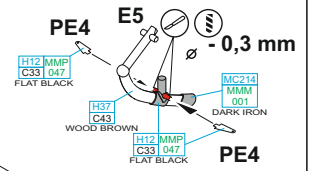
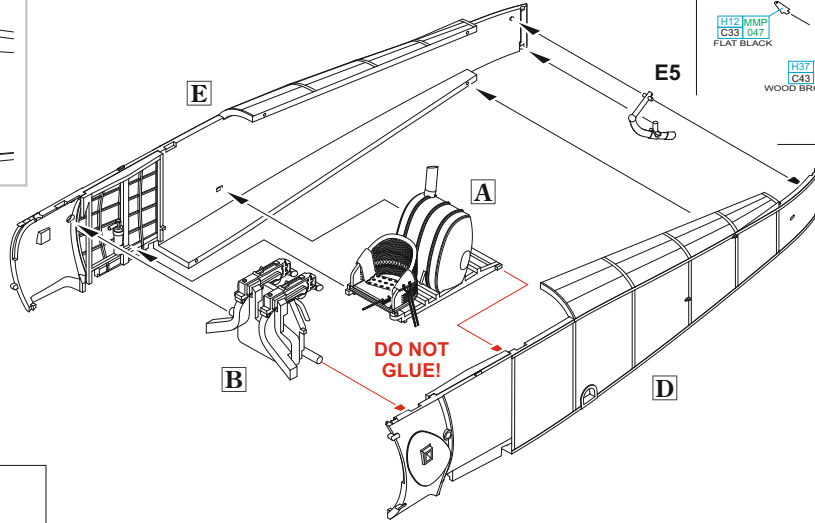
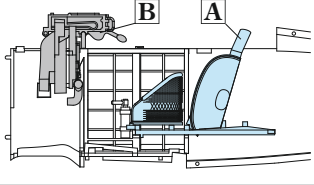

G Bentley engine

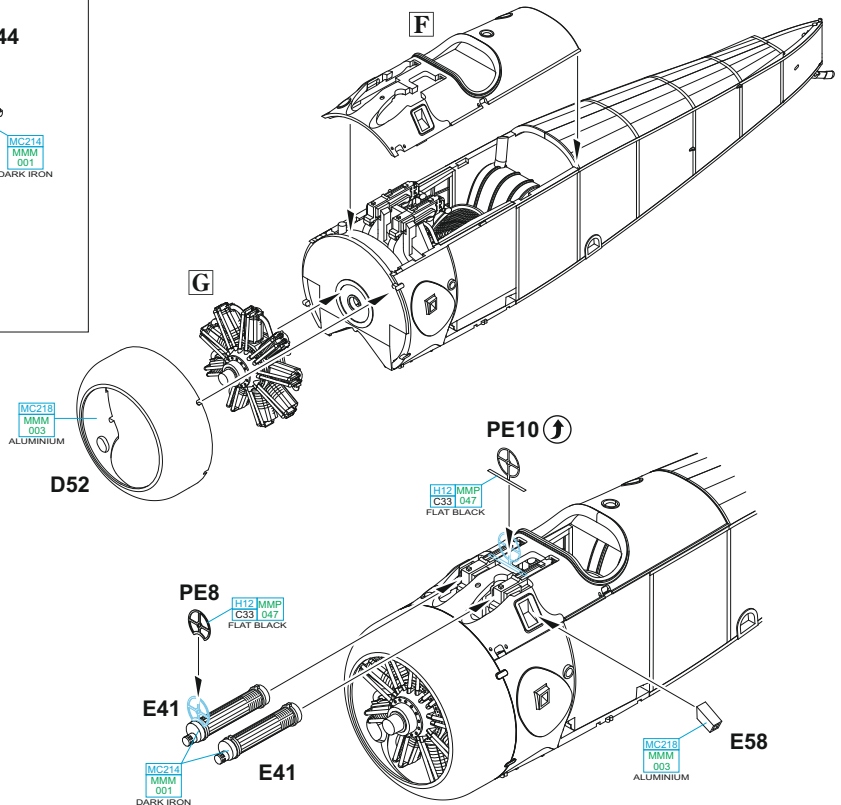
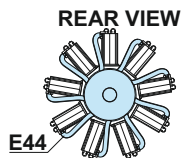
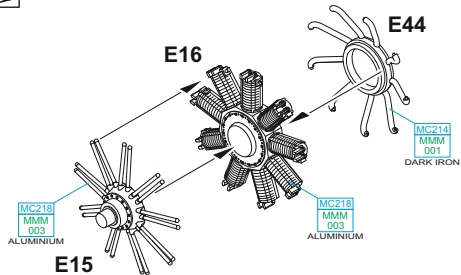

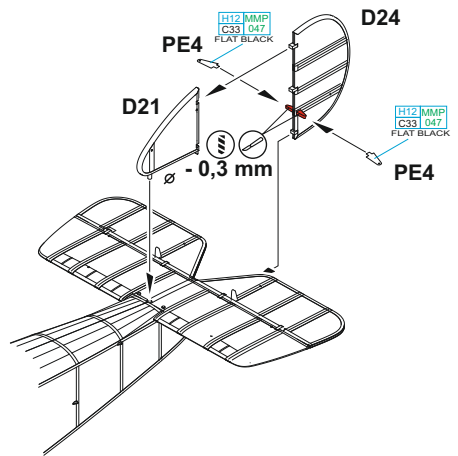
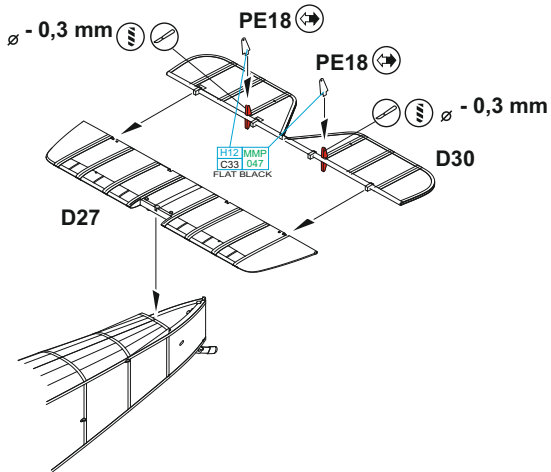

K

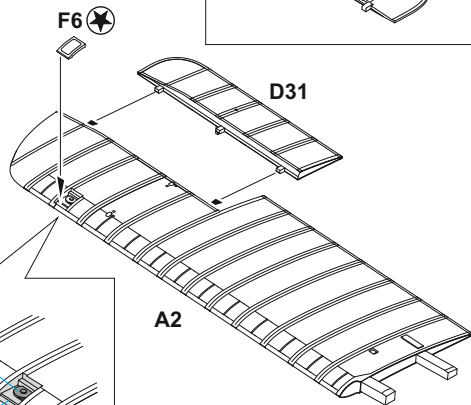
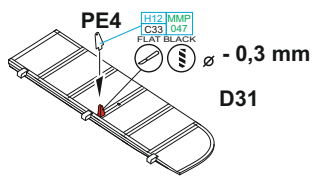

L

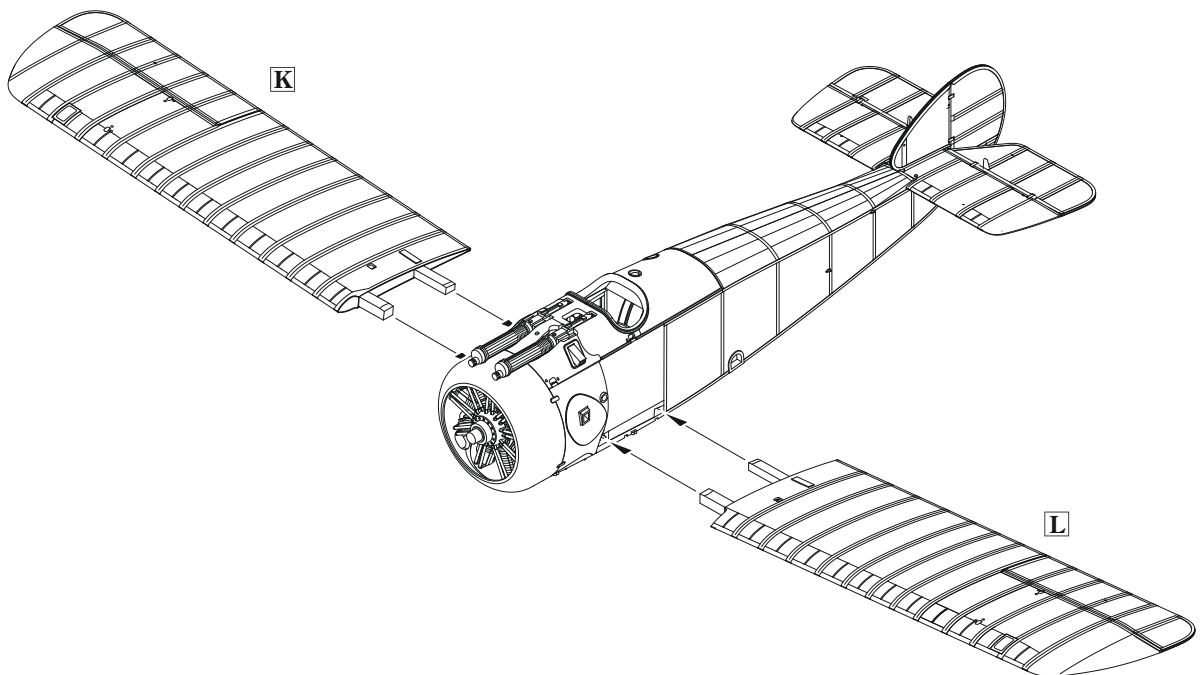
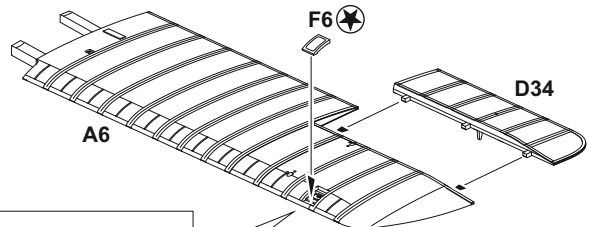
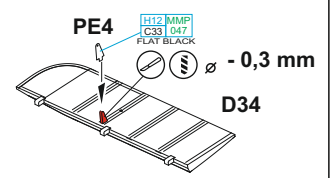

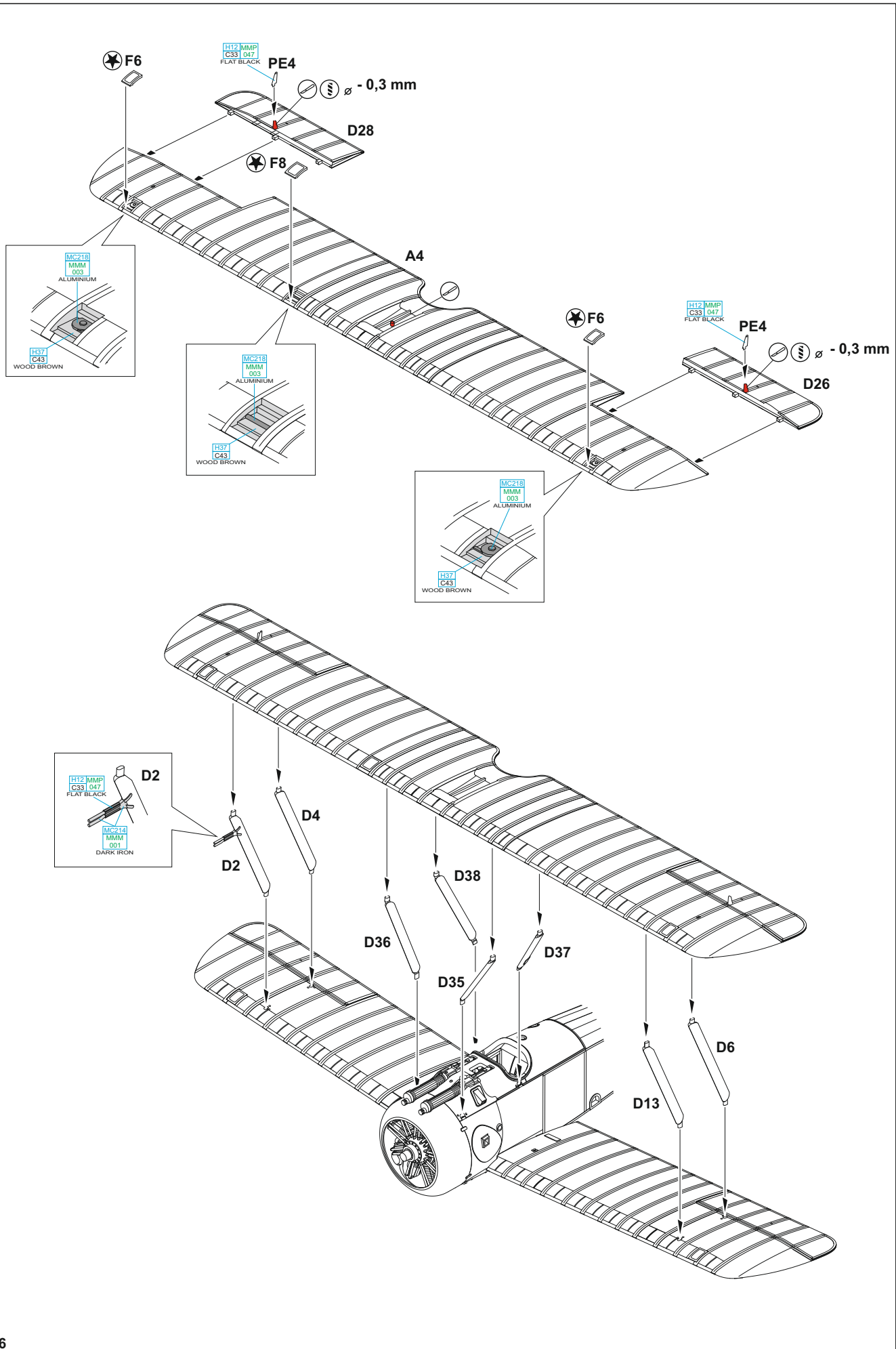

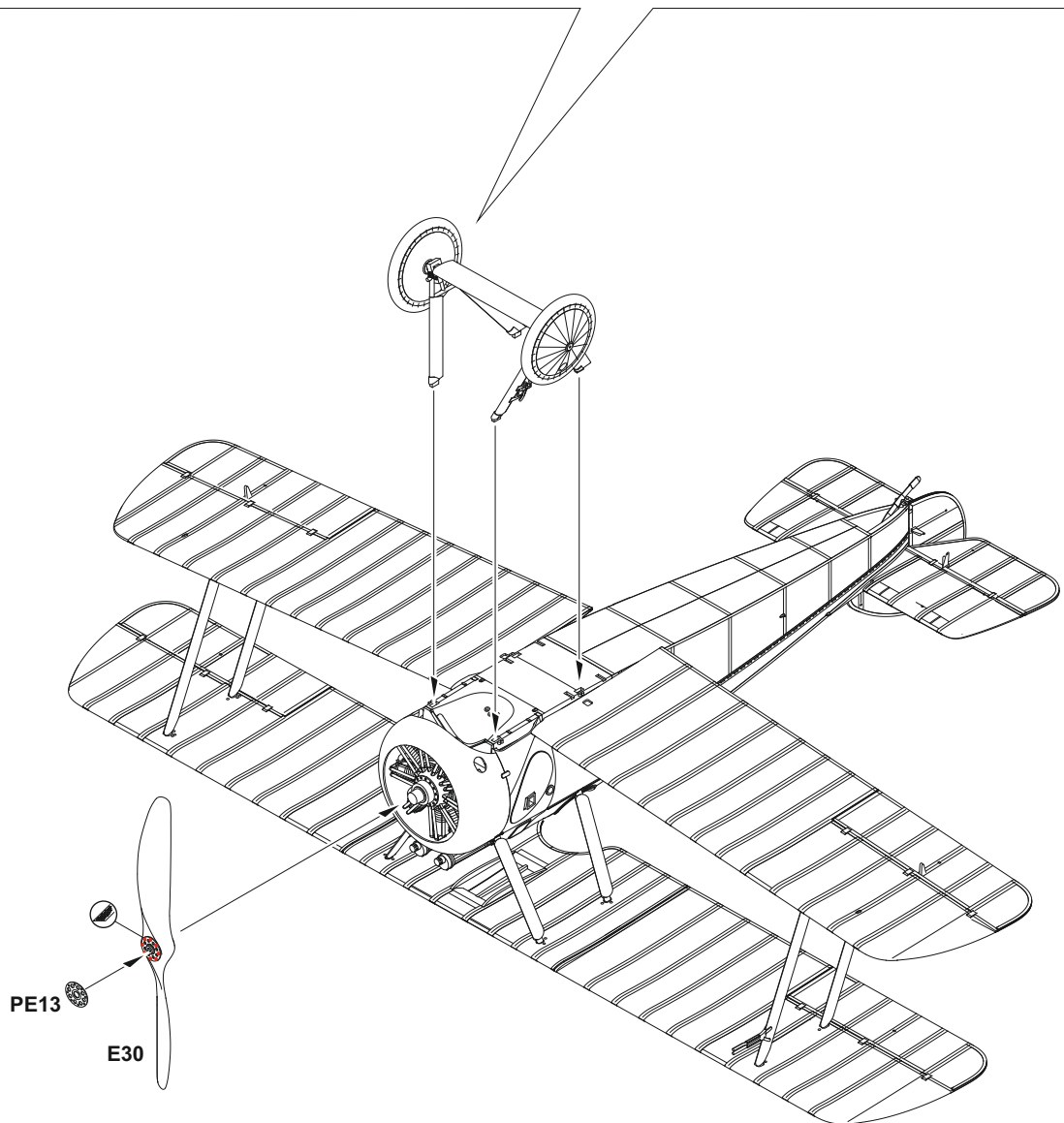
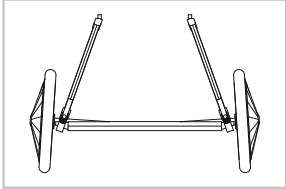
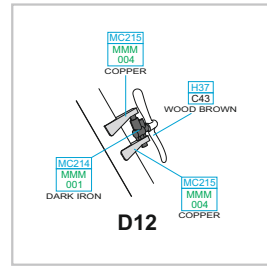
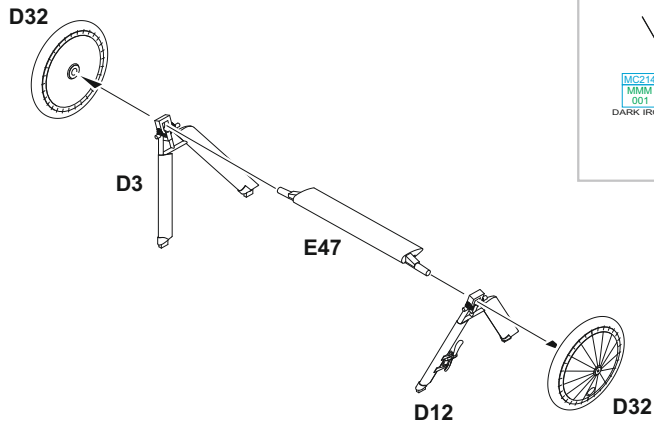

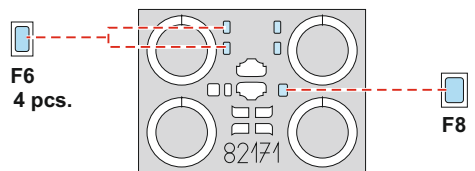
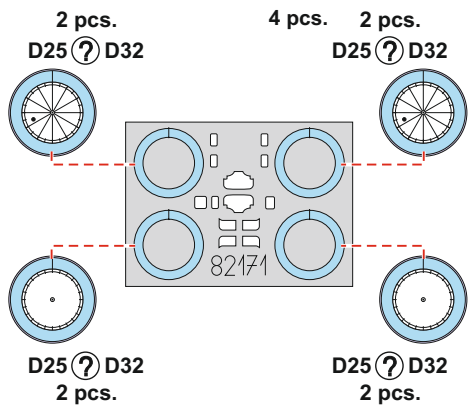
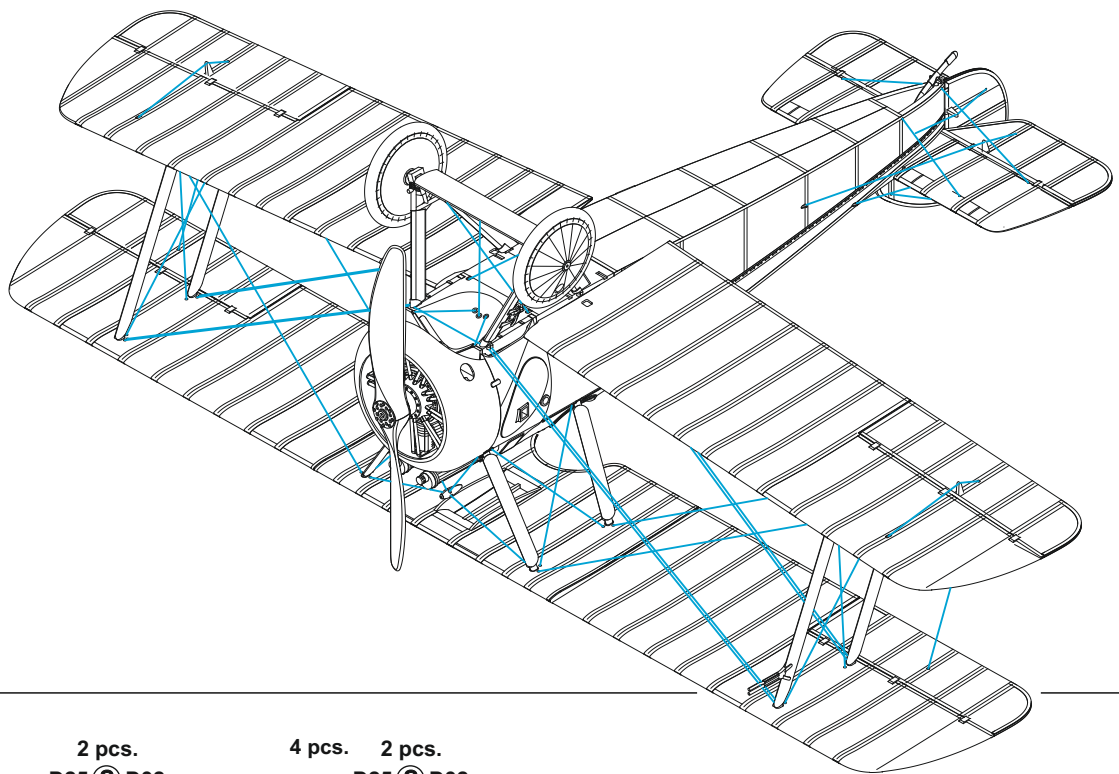
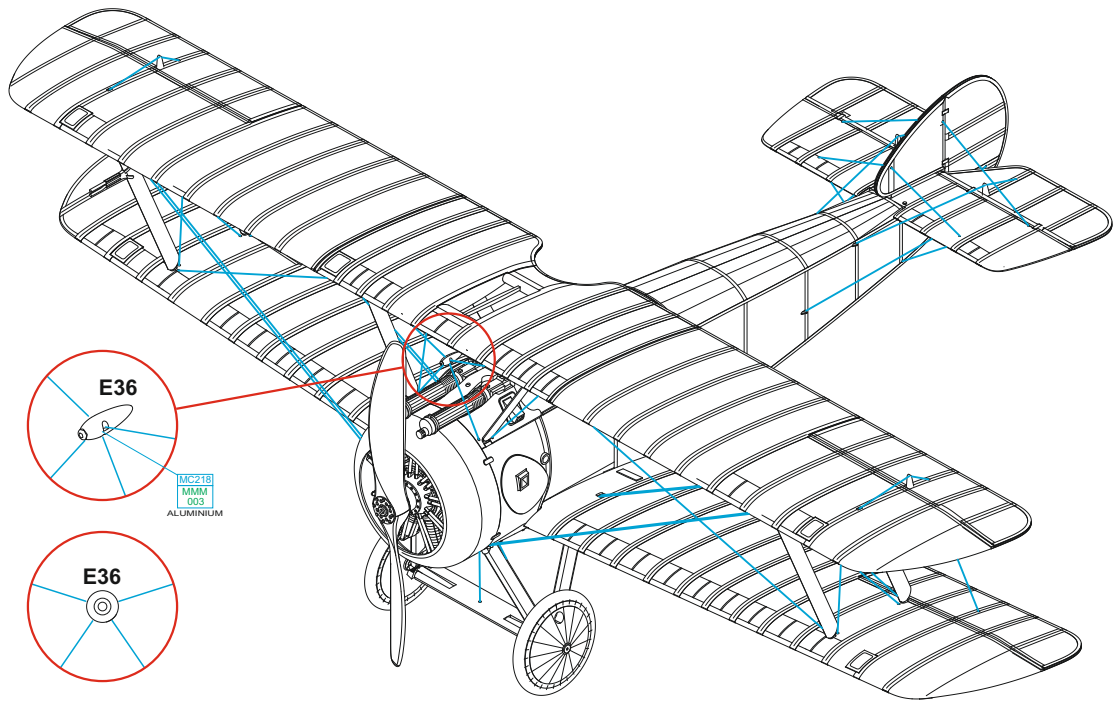

RIGGING DIAGRAM

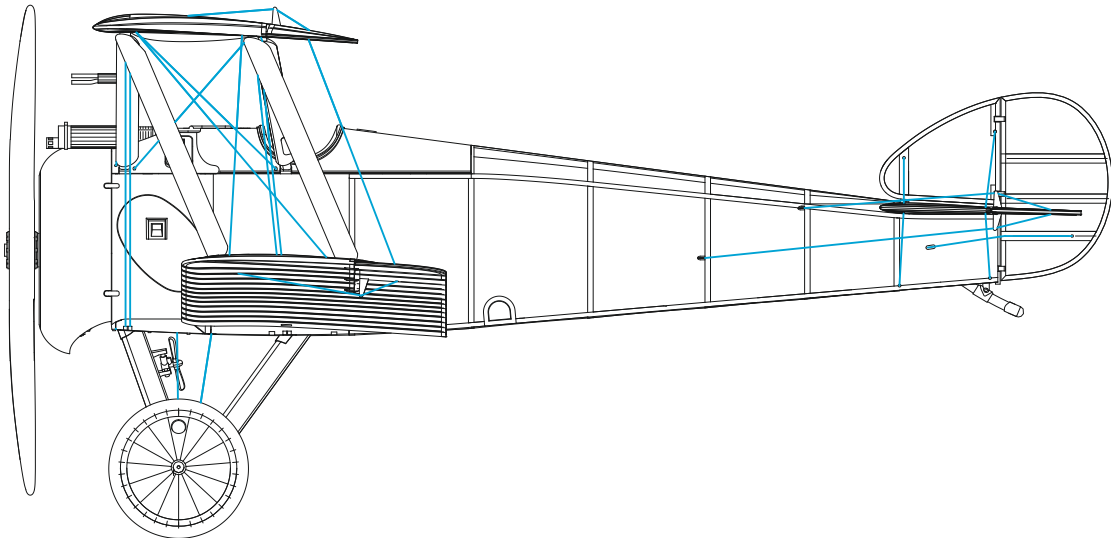
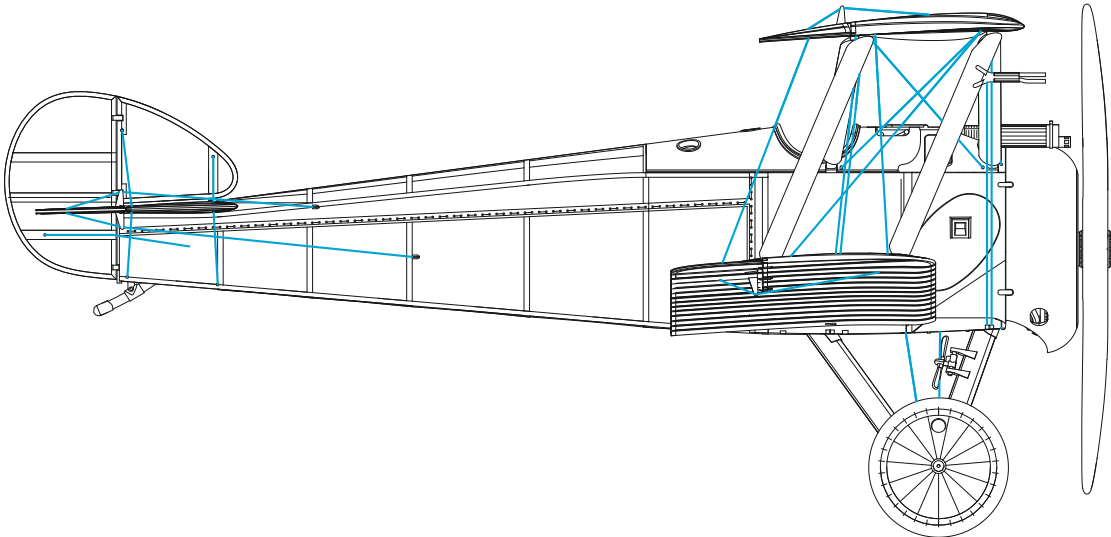
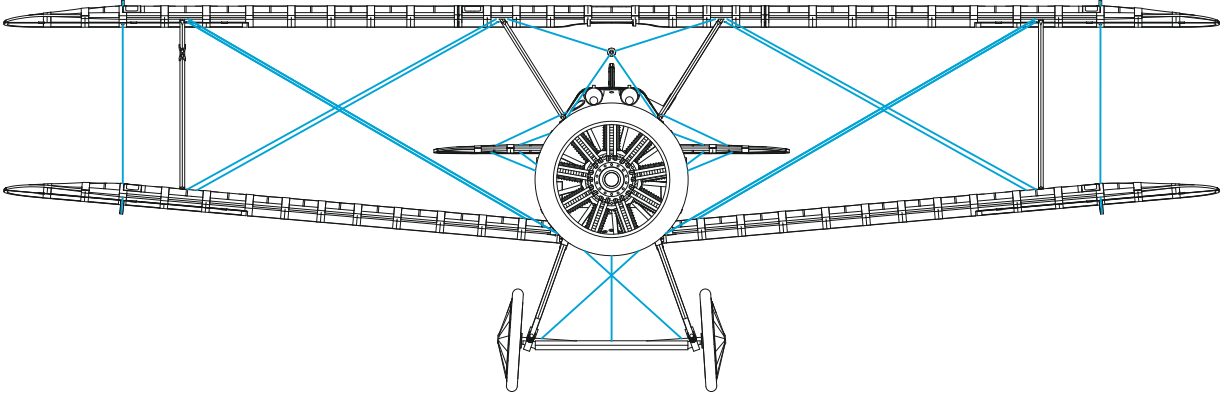

On January 23, 1918, eight Camels from No. 3(N) Squadron RNAS took off for offensive patrol at the Ostende – Torhout – Roulers line. Britons encountered a formation of four D.F.W.'s escorted by several D.IIIa Pfalz's from Jasta 7 over the Houthulst Forest (Forêt D'Houthulst). In the ensuing battle, one of the Camels crash-landed behind enemy lines. It was Camel flown by Flight Sub-Lieutenant Hubert St. John Edgerley Youens, a twenty year old inexperienced pilot. The one who, according to records, forced him to land was Carl Degelow, later commander of Jasta 40 and also the last pilot to be awarded Pour le Mérite during the Great War. The flight letter of B7184 remains unknown, as no photograph of this machine exists, partly because it was lost just nine days after it was taken into service on January 14, 1918. The marking of B7184 is usually compared to another Camel, the B7275, which bore the letter P in the blue field. However, this one joined No. 3(N) Sqn in March 1918, so the P letter cannot be excluded as possibility for B7184 as well.

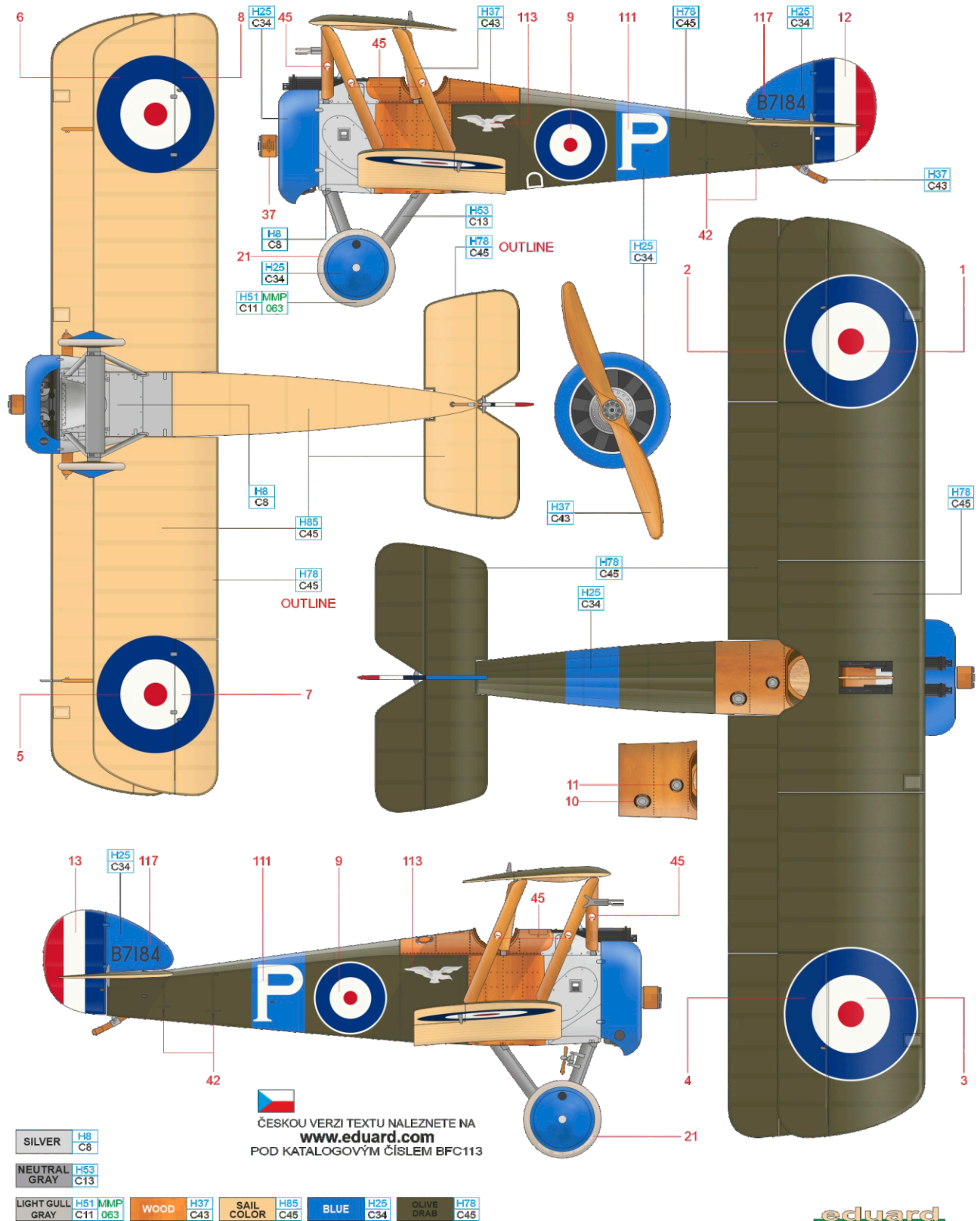

B B7184, Oblt. Otto Kissenberth, Jasta 23, Epinoy, France, May 1918

The Camel B7184 captured on January 23, 1918, was just slightly damaged and Luftstreitkräfte took the opportunity to flight-test the near-new condition enemy aircraft in the months following the incident. After the testing had been finalized, the Camel was used by Jasta 23 commanding officer Otto Kissenberth. German pilot even achieved a victory flying it when he shot down S.E.5a on May 16, 1918. It was his twentieth and last kill. Two weeks later he crashed this Camel shortly after take-off and severe injuries prevented him from return to combat action. The German livery is reasonably well documented. The British cockades were overpainted with white on the upper side of the top wing and with light yellow on the bottom of the lower wing while fuselage cockades disappeared under black fields on the fuselage sides. It is interesting the eagle symbol of the No.3(N) Sqn was retained. The horizontal stabilizer was given white and black stripe, the marking of Jasta 23.

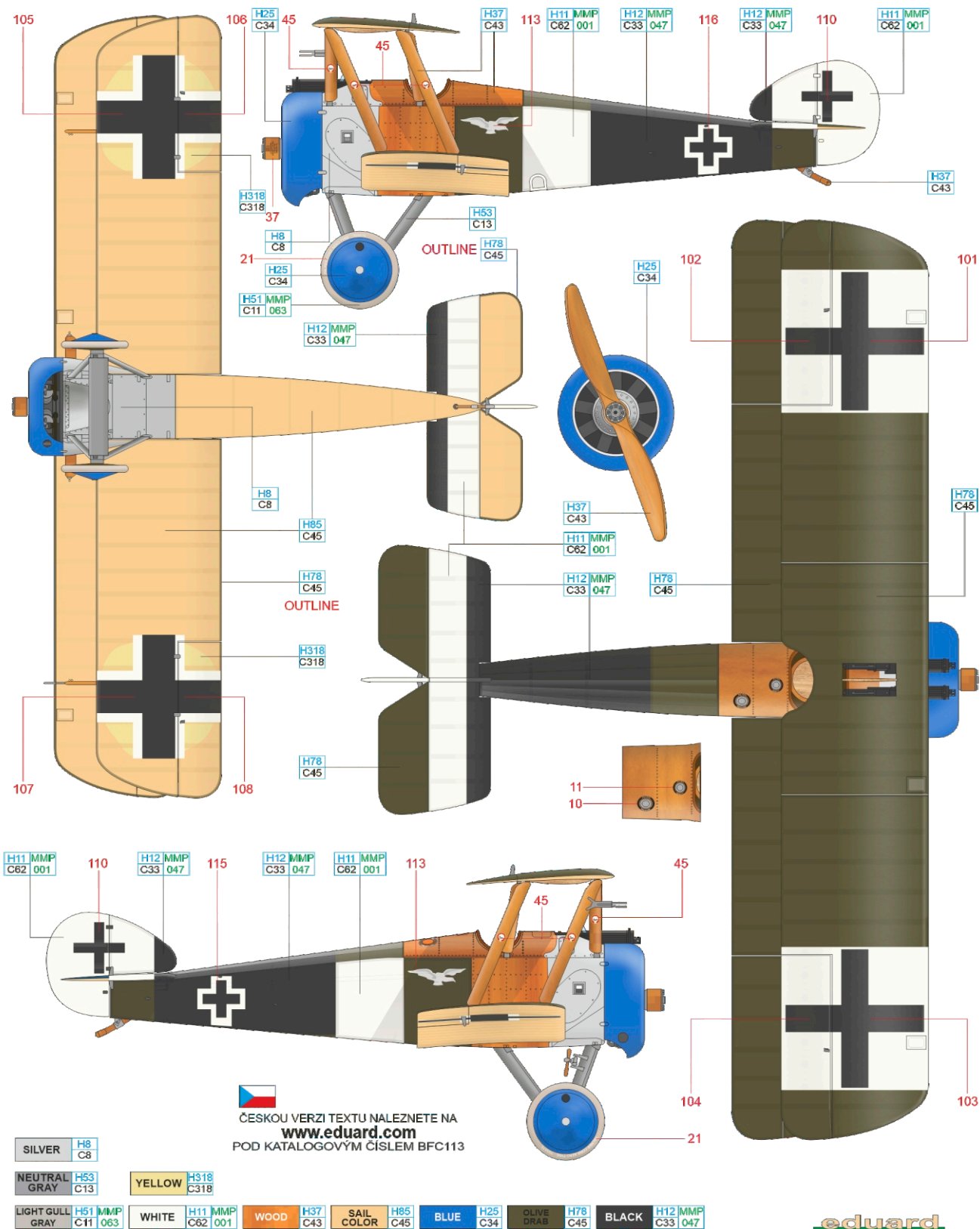

ČESKOU VERZI TEXTU NALEZNETE NA
www.eduard.com
 POD KATALOGOVÝM ČÍSLEM BFC113

SILVER H8 C8

NEUTRAL GRAY H53 C13

YELLOW H318 C318

LIGHT GULL GRAY H51 MMP C11 063

WHITE H11 MMP C62 001

WOOD H37 C43

SAIL COLOR H85 C45

BLUE H25 C34

OLIVE DRAB H78 C45

BLACK H12 MMP C33 047

eduard