

# PZL P.11b in Romanian Service



Cat. No. 72518  
Scale 1/72



3d design: Przemysław Głogowski  
Research: IBG Crew

**IBG Models pragnie podziękować Panom Radu Brinzanowi i Horii Stoicy za pomoc przy opracowaniu tego modelu!**  
*IBG Models would like to thank Mr. Radu Brinzan and Horia Stoica for help in developing this model!*

Samolot myśliwski, będący eksportową odmianą wersji P.11a, opracowany pod kierownictwem inż. Wsiewołoda Jakimiuka jako rozwinięcie samolotu P.6 konstrukcji inż. Zygmunta Puławskiego.

Już w połowie 1932 r. francuska wytwórnia silników Gnome-Rhône wyraziła zainteresowanie wyposażeniem obiecującej konstrukcji P.11 w swój silnik, licząc na zamówienia eksportowe. Jeszcze w tym samym roku prototyp P.11/IV z silnikiem Gnome-Rhône 9Kcr Mistral o mocy 550 KM został zaprezentowany w barwach polskiego lotnictwa wojskowego na Międzynarodowym Salonie Lotniczym w Paryżu. Wzbudził zainteresowanie sił powietrznych Turcji, Rumunii, Portugalii, Grecji, Szwecji, Czechosłowacji, Japonii i Jugosławii.

Kilka z tych krajów zdecydowało się na zakup późniejszej wersji samolotu P.24, natomiast Rumunia zamówiła wersję samolotu P.11 wyposażoną w silnik GR 9Krsd produkowany w Rumunii na licencji. Tak napędzany samolot otrzymał oznaczenie P.11b. Ponieważ strona rumuńska wymagała bardzo szybkiego terminu dostawy gotowych maszyn, zakłady PZL rozpoczęły ich produkcję przed wariantem P.11a dla lotnictwa polskiego. Aby przyspieszyć prace, wykorzystano część rozwiązań konstrukcyjnych (skrzydło) z poprzedniego typu myśliwca, PZL P.7a. Zamówienie, opiewające na 50 sztuk płatowców, zrealizowano na przełomie lat 1933-34.

Do dziś nie zachował się żaden egzemplarz myśliwca P.11b.

Fighter plane, an export version of P.11a, designed under inż. Wsiewołod Jakimiuks supervision as a development of inż. Zygmunt Puławski's P.6 construction.

Already in mid 1932 French engine manufacturer Gnome-Rhône expressed interest in equipping P.11 construction with their engine, counting on export orders. In the same year the prototype – P.11/IV with Gnome-Rhône 9Kcr Mistral 550 hp engine was presented in Polish Airforce colors on the International Air Exhibition. It aroused interest of Turkish, Romanian, Portugese, Greek, Swedish, Czechoslovak, Japanese and Yugoslavian airforces.

Several of these countries decided to purchase the subsequent P.24 version of the plane, only Romania ordered the P.11 version equipped with GR 9Krsd produced in Romania under licence. Plane with such propulsion was named P.11b. Because of the Romanian side demand to deliver the planes on short notice PZL factory started their production even before the P.11a for Polish Airforce. To speed up the works some of the structural solutions (the wing) from previous project – PZL P.7a were used. The order for 50 planes was delivered at the turn of 1933 and 34.

No P.11b plane survived until this day.



**Element złożony we wcześniejszym etapie**  
*Element assembled in previous step*



**Kolor farby**  
*Paint colour*



**Wersja do wyboru**  
*Version to choose*



**Element po złożeniu w aktualnym etapie**  
*Element after assembly in current step*



**Kalkomania**  
*Decal*

## Elementy Fototrawione / Photo-etched Parts

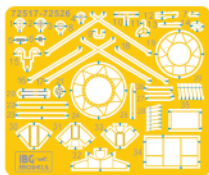

## Kalkomanie / Decals



**Przed montażem przeczytać instrukcję. Przestrzegać kolejności montażu podanego w instrukcji. Klej i farby nie wchodzi w skład zestawu.**  
*Please read instructions before assembly. Follow the sequence of assembly presented in instructions. Glue and paint not included.*

IBG Models  
ul. Benedykta Hertza 2  
04-603 Warszawa  
Poland

tel +48 22 8159150  
fax +48 22 8159151  
ibgsc@ibg.com.pl  
www.ibg.com.pl  
www.ibgmodels.com

**Elementy modelu**  
*Elements of the model kit*

**Ramka A / Frame A**

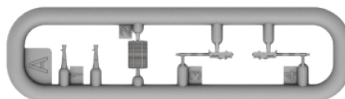

**Ramka B / Frame B**

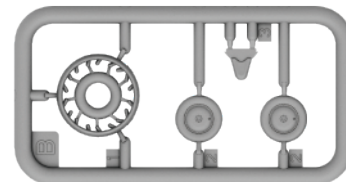

**Ramka K przezroczysta / Frame K transparent**

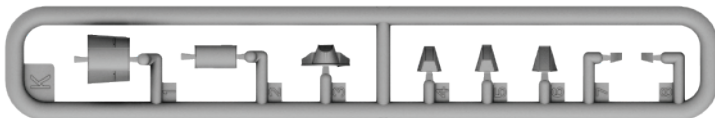

**Ramka P / Frame P**

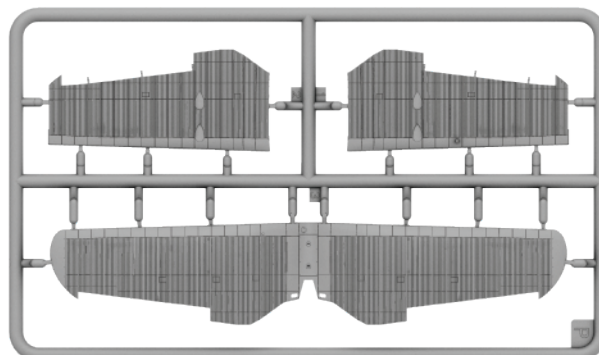

**Ramka G / Frame G**

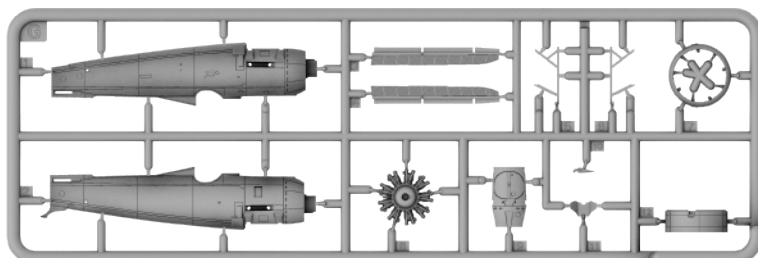

**Ramka T / Frame T**

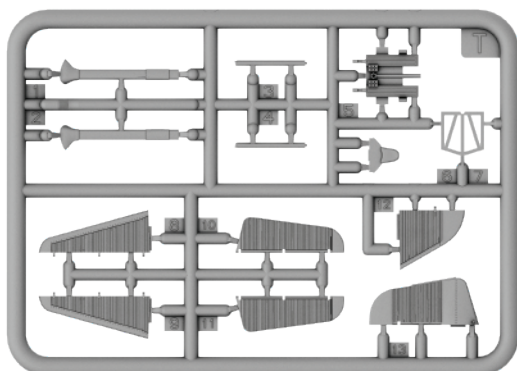

**Ramka V / Frame V**

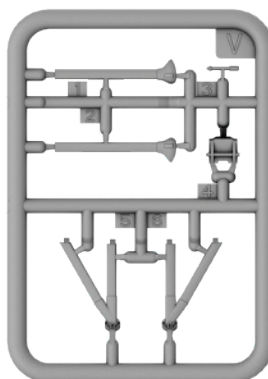

**Ramka J / Frame J**

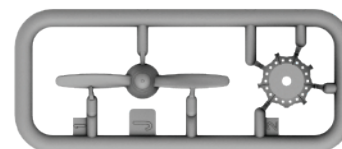

|                   |   | VALLEJO | HATAKA   | LIFE COLOR | MR HOBBY | AK INTERACTIVE | MISSION MODELS |
|-------------------|---|---------|----------|------------|----------|----------------|----------------|
| Dark Earth        | A | 71.323  | HTK-_009 | UA547      | H72      | RC287          | MMP078         |
| Black             | B | 71.057  | HTK-_100 | LC02       | H12      | RC001          | MMP047         |
| Silver            | C | 71.067  | HTK-_003 | LC24       | H8       | AK479          | MMP006         |
| Rust              | D | 71.130  | HTK-_132 | LC32       | H47      | AK708          | MMW001         |
| Sky Blue          | E | 71.404  | HTK-_028 | UA518      | H418     | RC291          | MMP080         |
| Brown Leather     | F | 72.740  | HTK-_186 | UA764      | H460     | AK3031         | MMP-002        |
| Black Leather     | G | 71.057  | HTK-_100 | UA763      | H12      | AK3034         | MMP-040        |
| Gunmetal          | H | 71.072  | HTK-_106 | LC26       | H018     | AK798          | MMM-010        |
| Dark Green        | J | 71.324  | HTK-_016 | UA546      | H73      | RC286          | MMP-077        |
| Sand              | K | 71.074  | HTK-_097 | UA090      | H318     | RC227          | MMP-129        |
| Yellow            | L | 71.002  | HTK-_107 | LC03       | H34      | RC007          | MMP041         |
| Light Brown       | M | 71.027  | HTK-_074 | UA767      | H455     | AK787          | MMP131         |
| Polish Dark Khaki | N | 71.265  | HTK-_010 | TM008      | H420     | RC042          | MMP026         |
| White             | S | 71.001  | HTK-_101 | LC01       | H1       | RC004          | MMP001         |
| Terracota         | T | 71.038  | HTK-_130 | UA211      | H47      | RC066          | MMP142         |
| Light Olive Green | U | 71.126  | HTK-_091 | UA060      | H312     | RC232          | MMP018         |
| Olive Green       | W | 71.289  | HTK-_021 | UA206      | H6       | RC231          | MMP032         |
| Light Blue-Grey   | X | 71.046  | HTK-_036 | TM009      | H67      | RC239          | MMP096         |

**Malowanie wnętrza**  
*Painting of the interior*

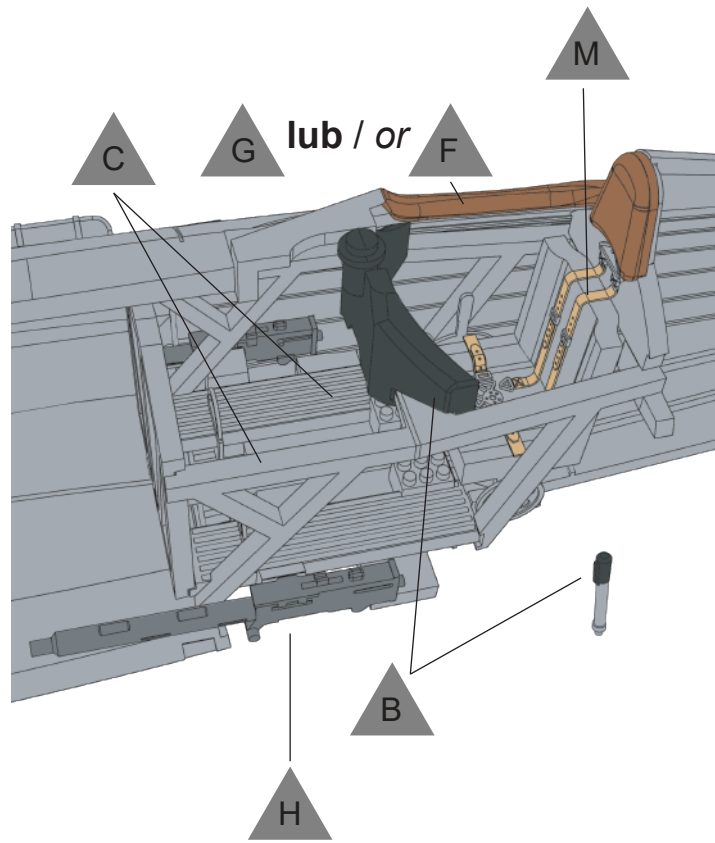

**Etap 1**  
*Step 1*

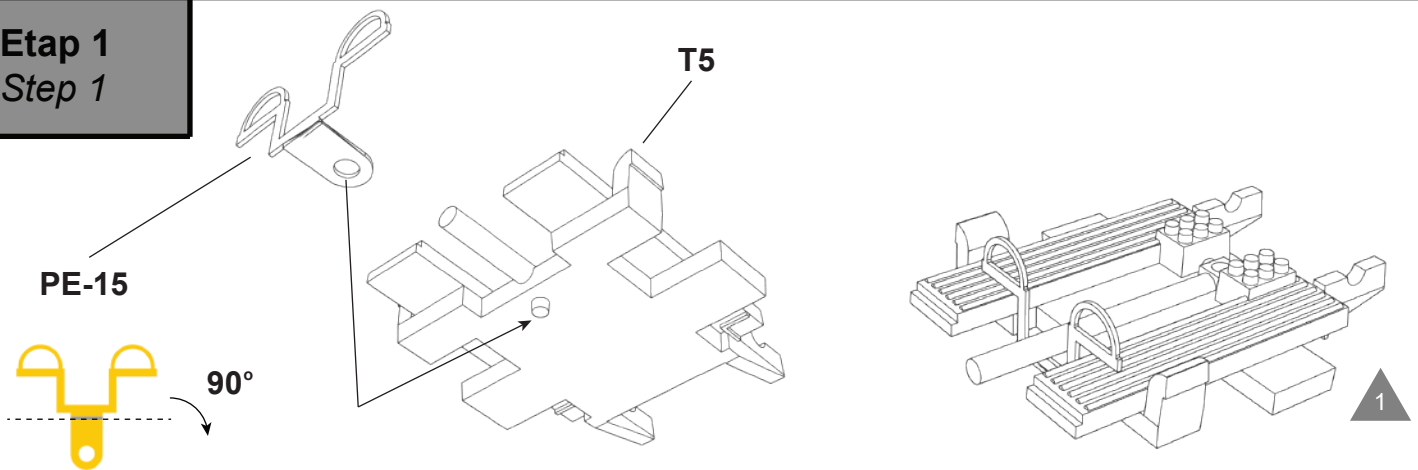

**Etap 2**  
*Step 2*

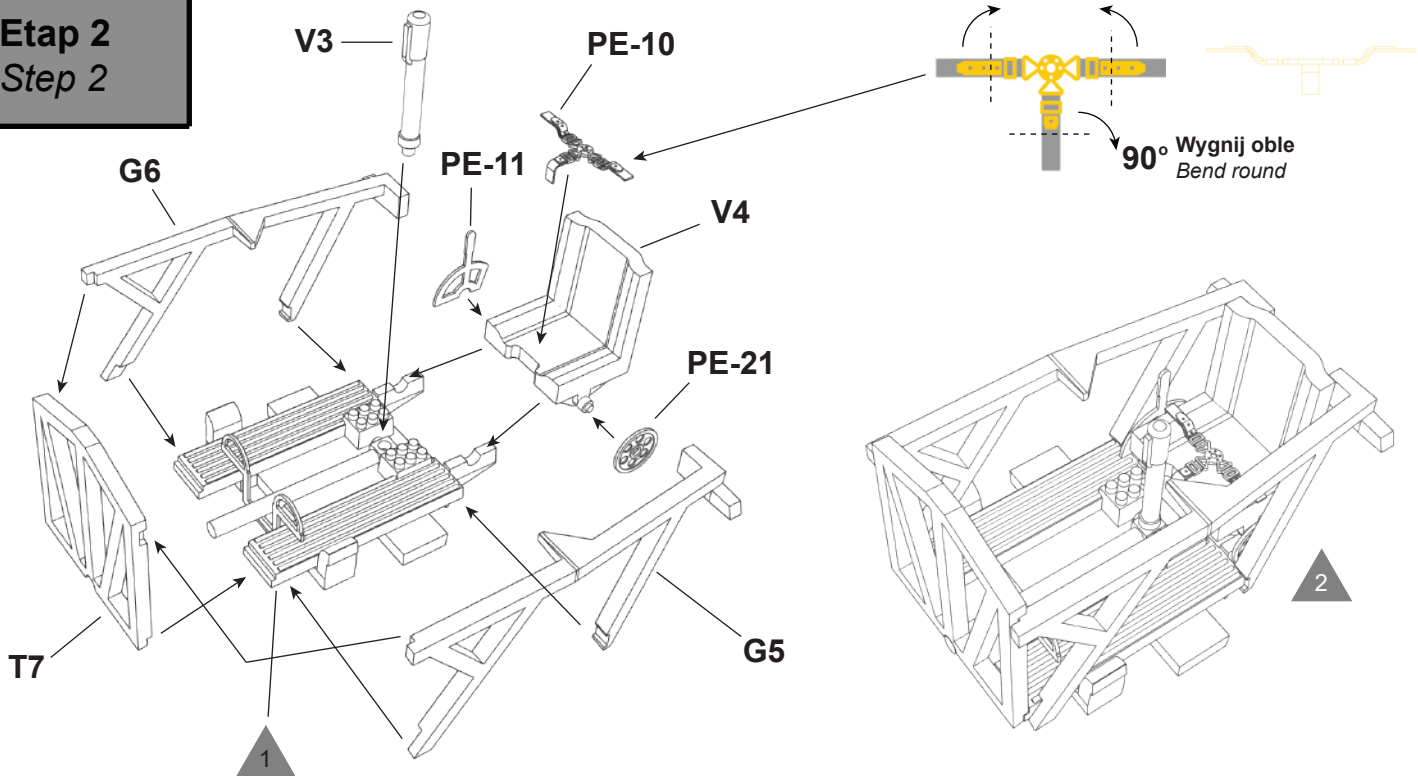

**Etap 3**  
*Step 3*

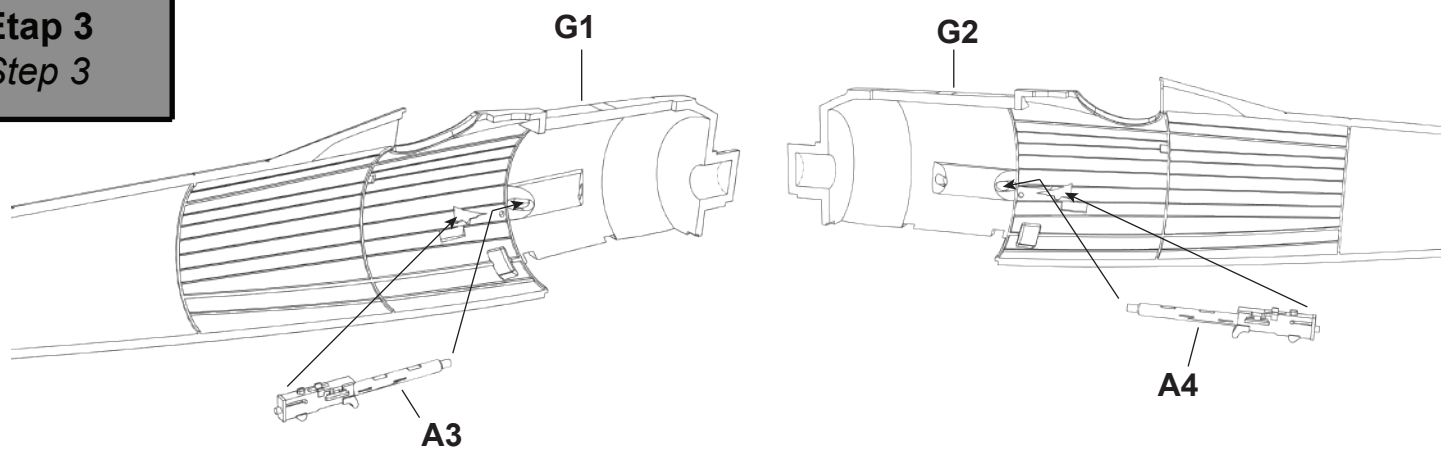

**Etap 4**  
*Step 4*

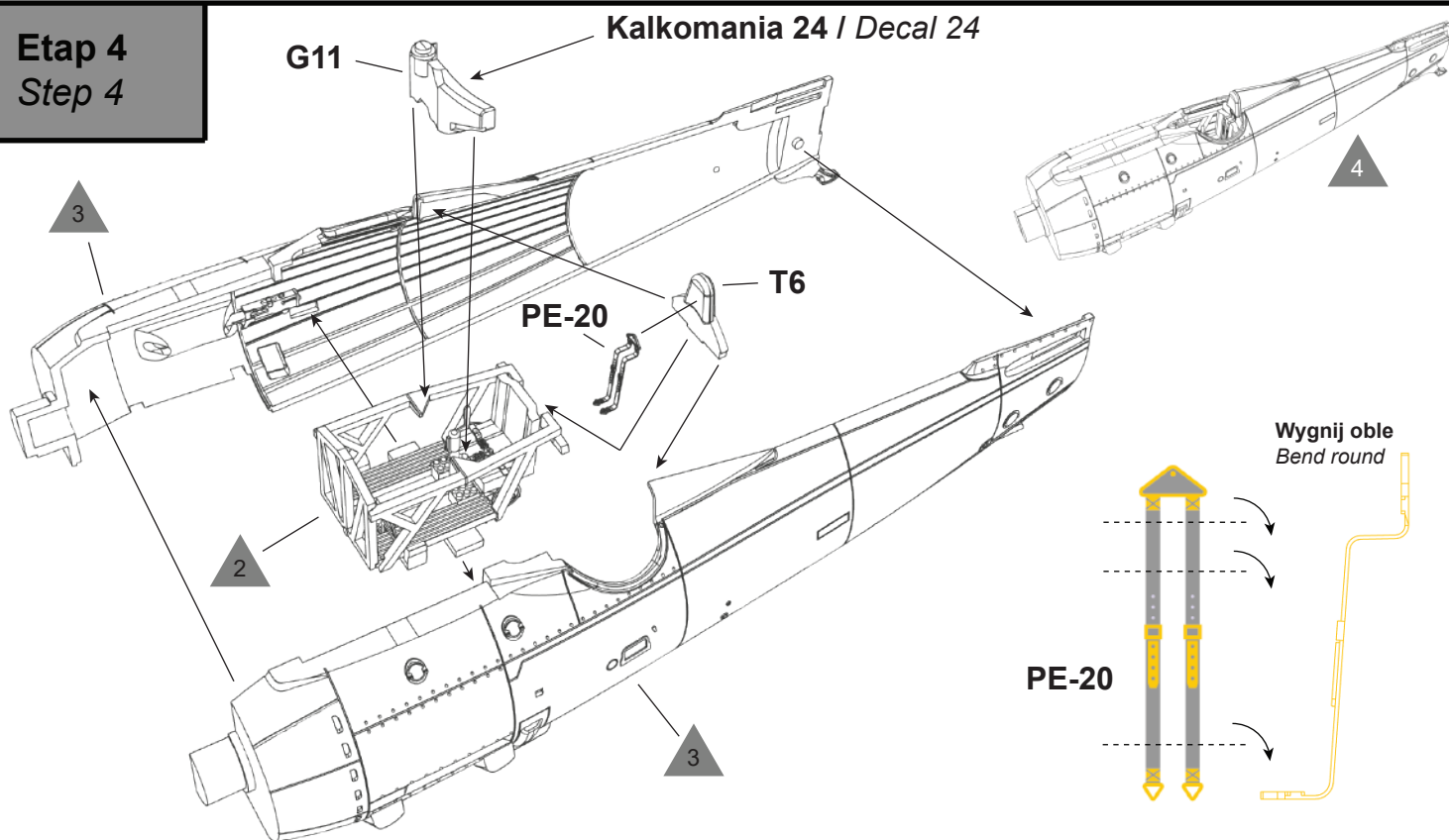

**Etap 5**  
*Step 5*

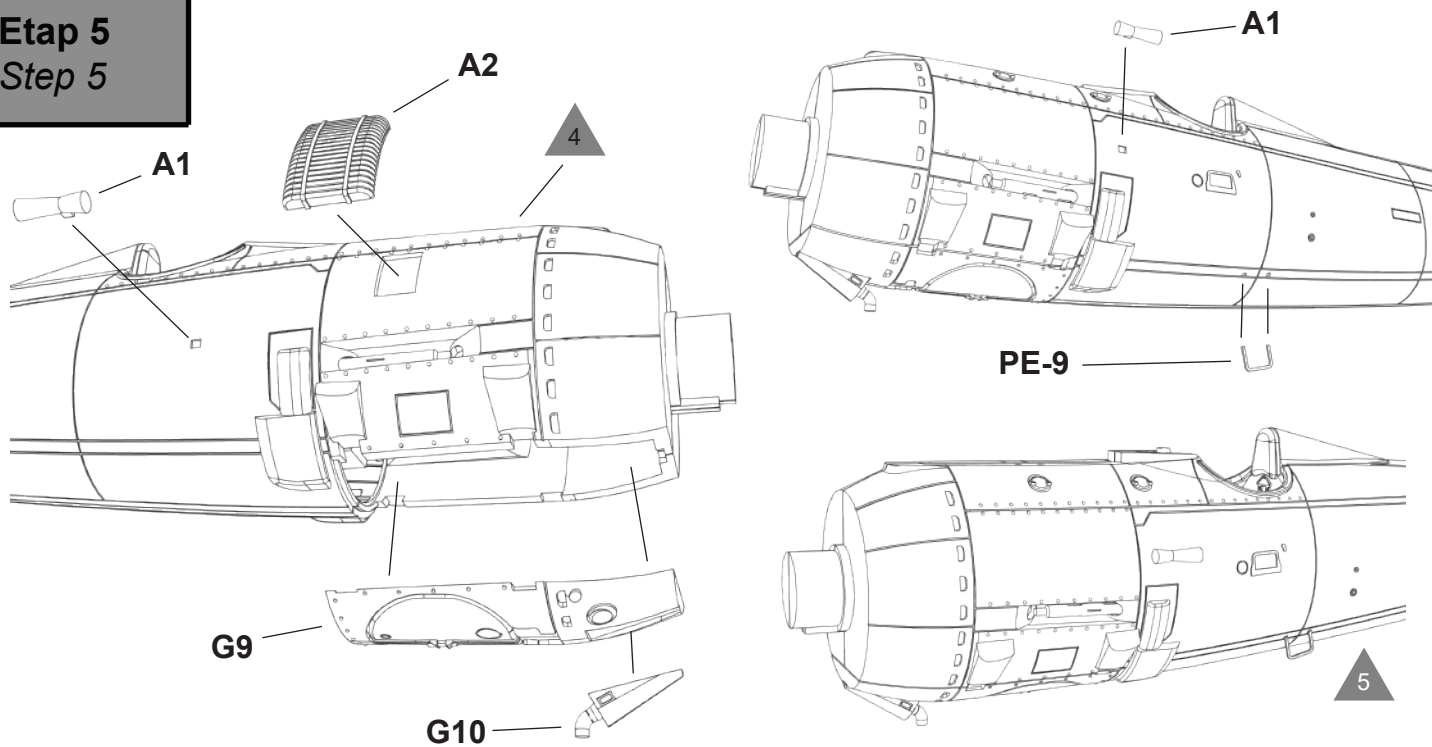



**Etap 6**  
*Step 6*

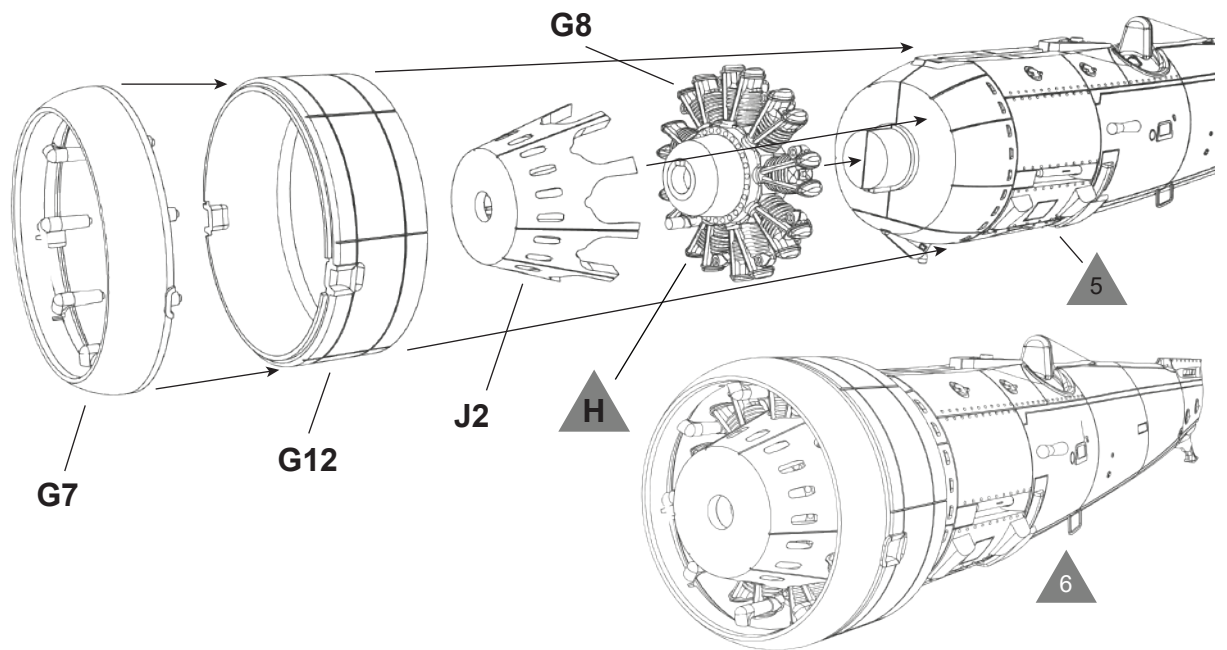

**Etap 7**  
*Step 7*

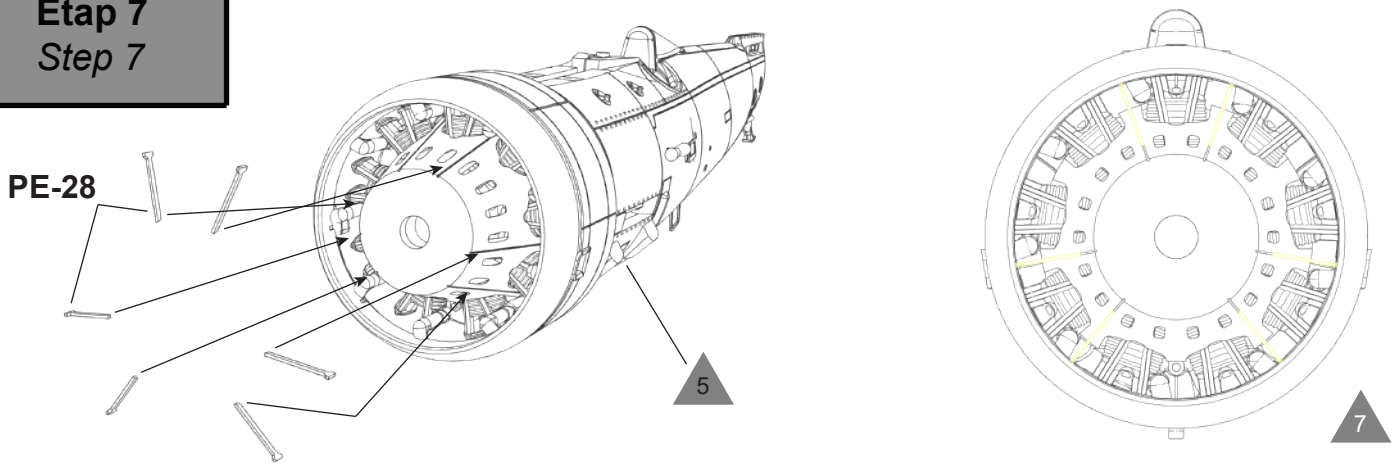

**Etap 8**  
*Step 8*

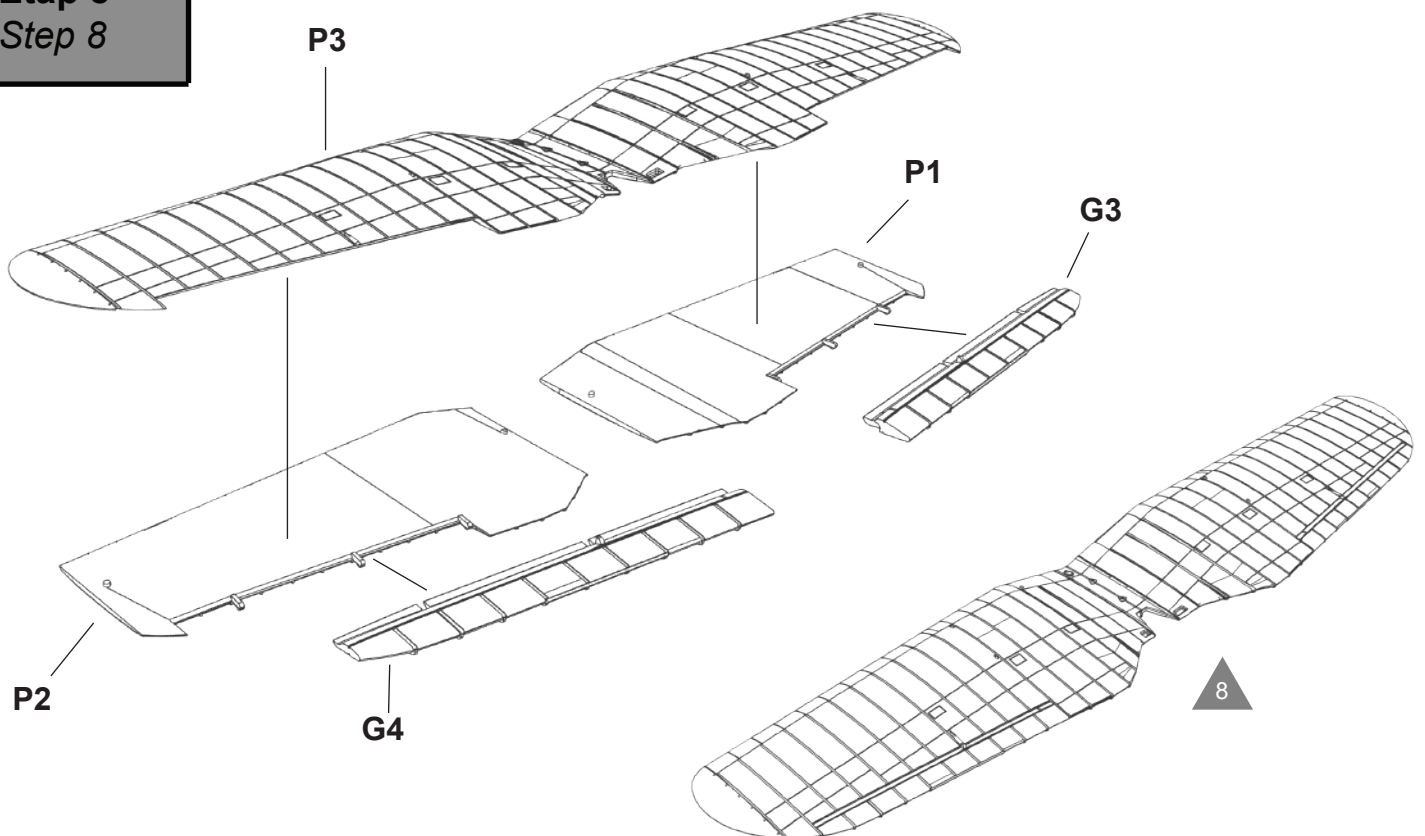

**Etap 9**  
**Step 9**

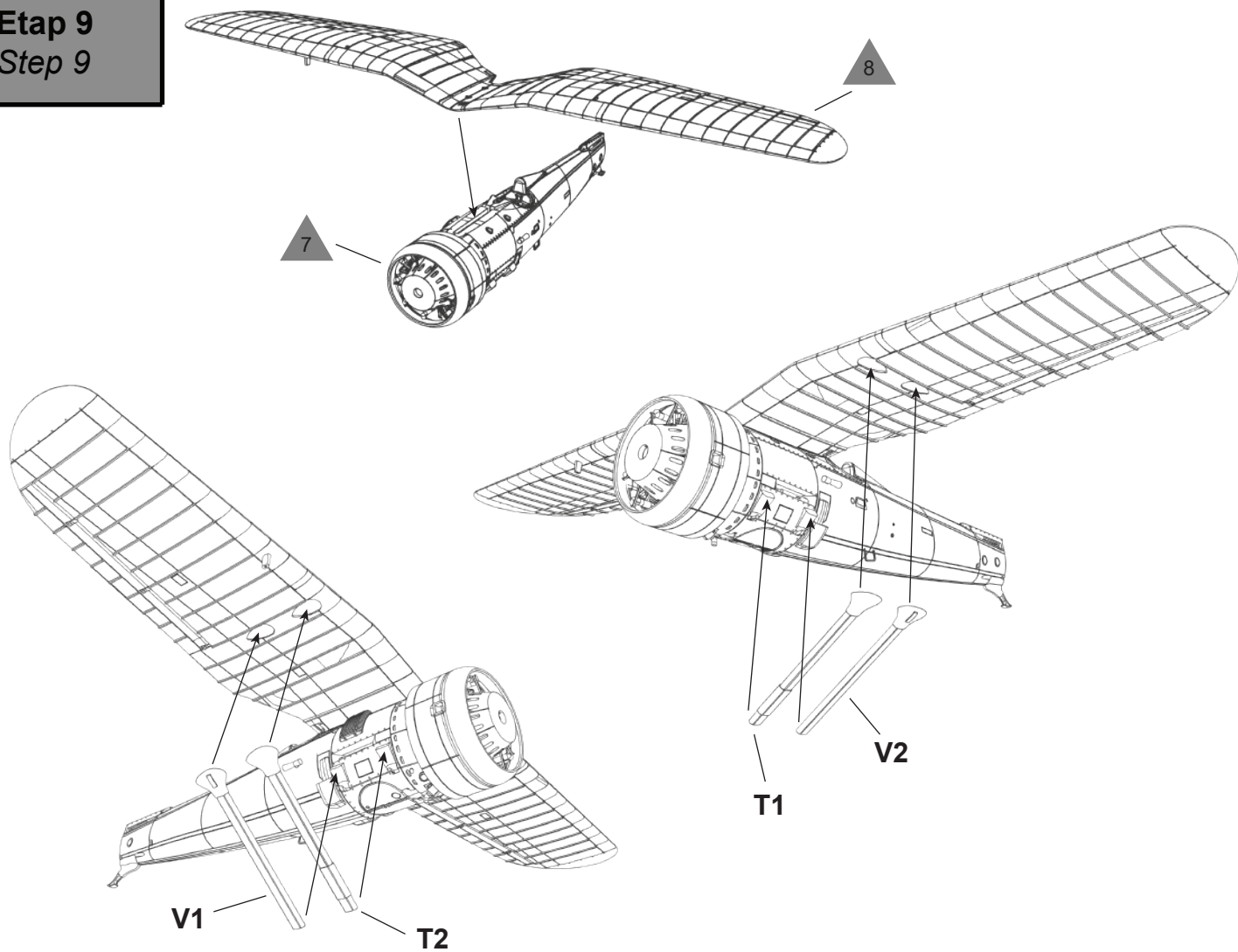

**Etap 10**  
**Step 10**

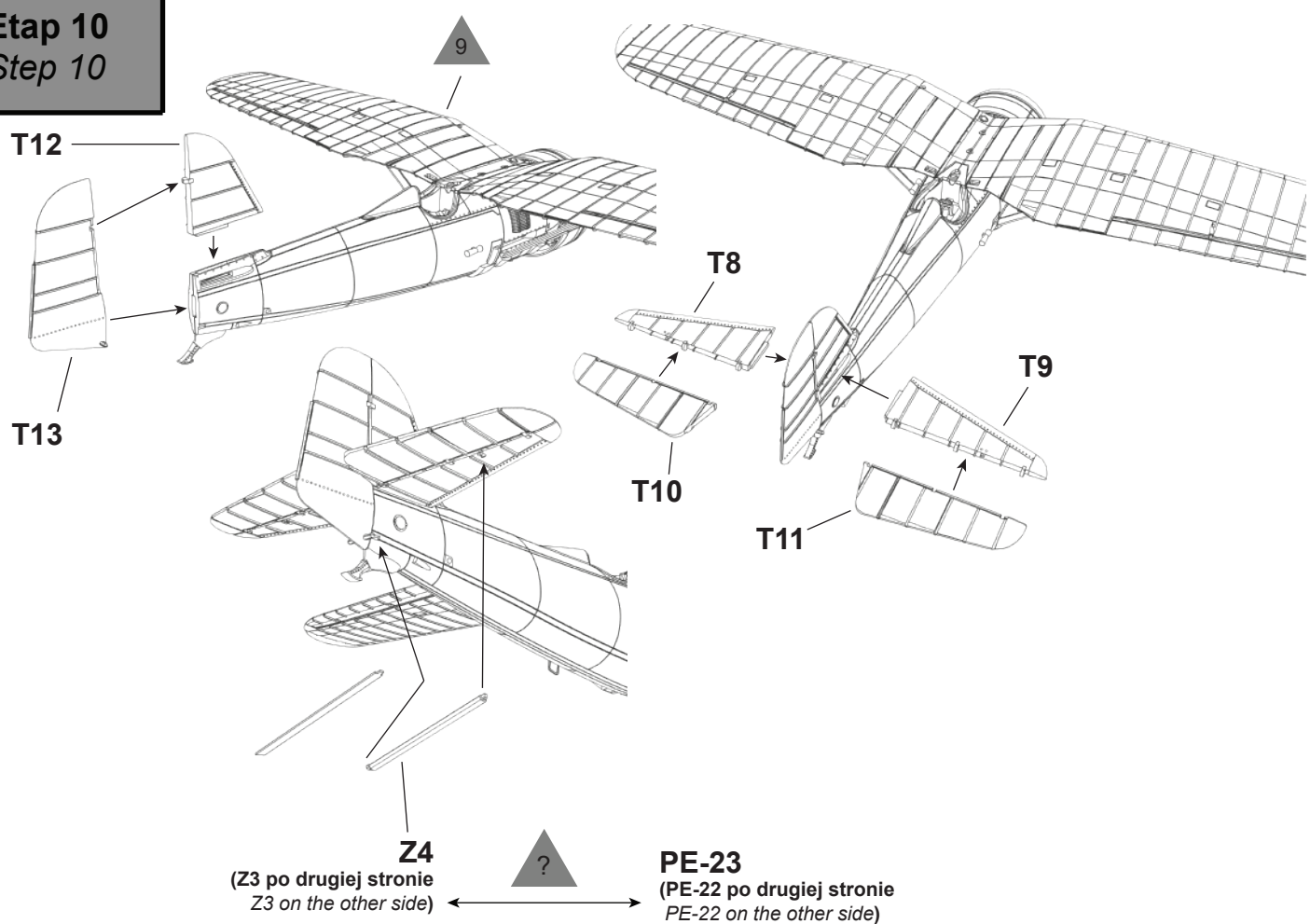

**Etap 11**  
**Step 11**

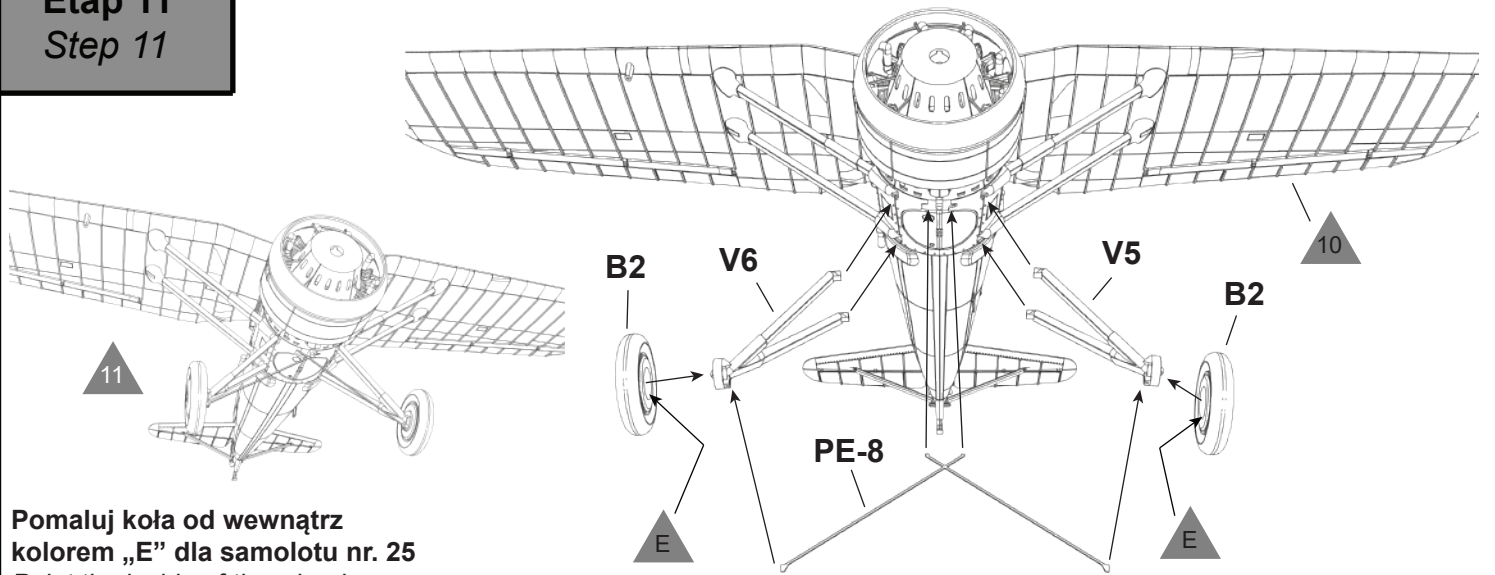

**Pomaluj koła od wewnątrz**  
**kolorem „E” dla samolotu nr. 25**  
*Paint the inside of the wheels*  
*in color „E” for the plane no. 25*

**Etap 12**  
**Step 12**

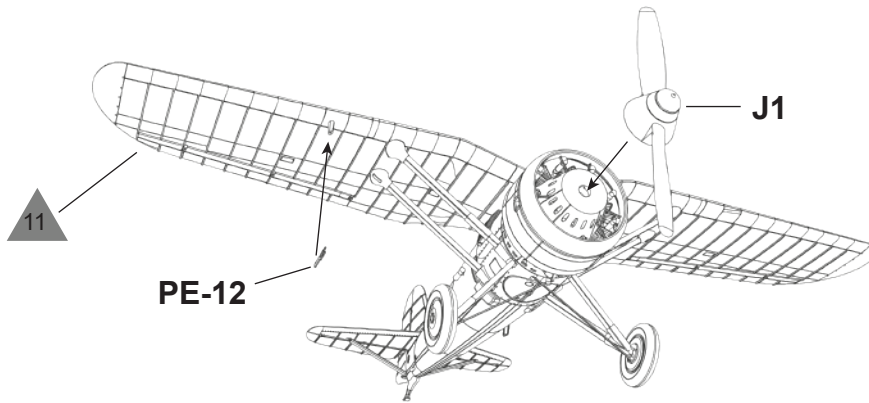

**Etap 13**  
**Step 13**

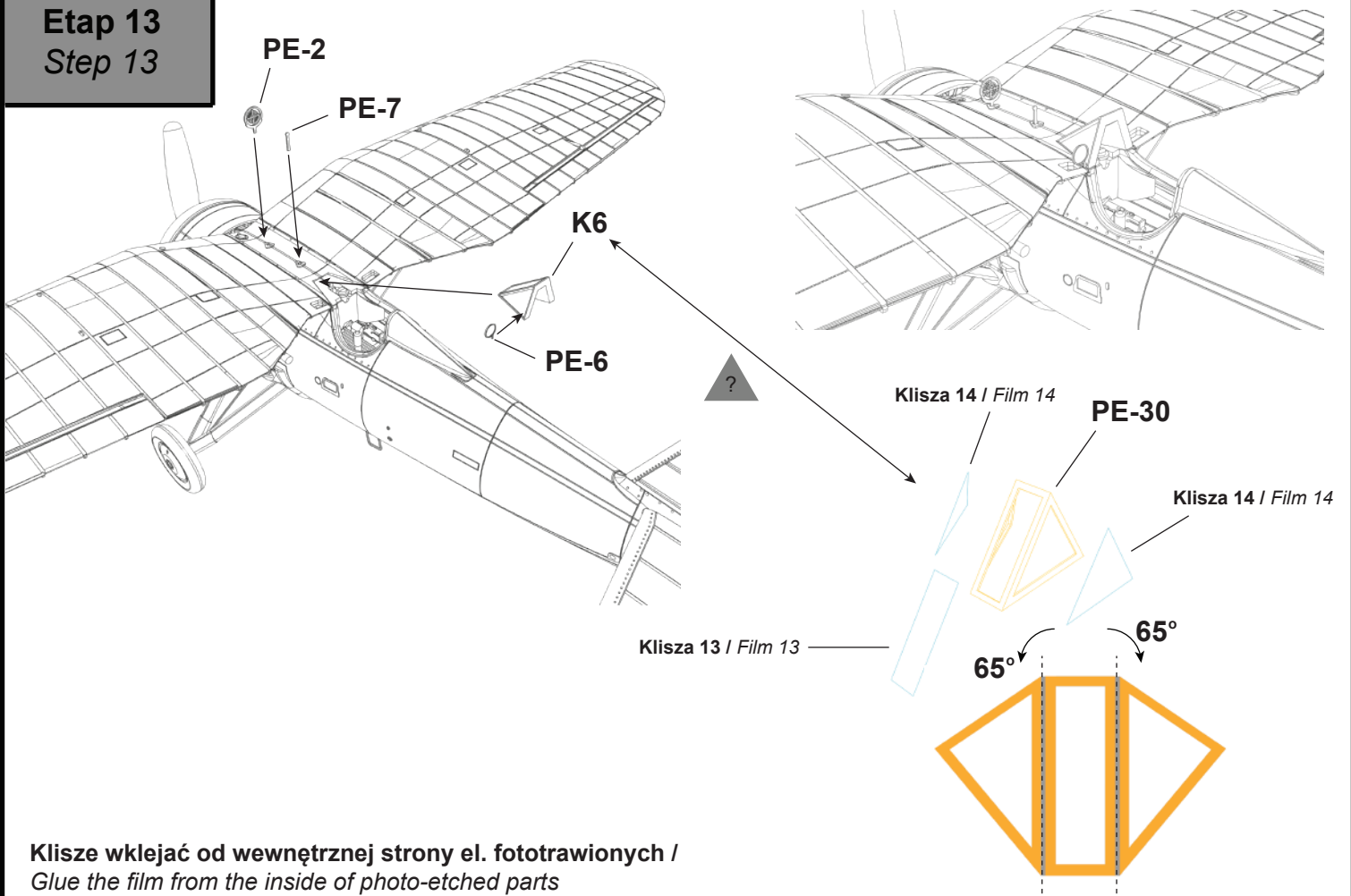

**Klisze wklejać od wewnętrznej strony el. fototrawionych /**  
*Glue the film from the inside of photo-etched parts*



**Wykonany Model**  
*Built Model*

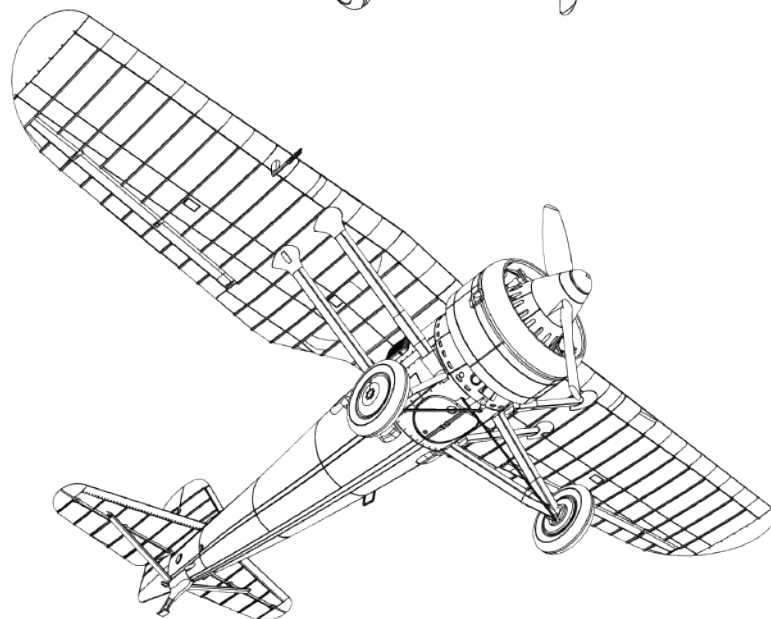
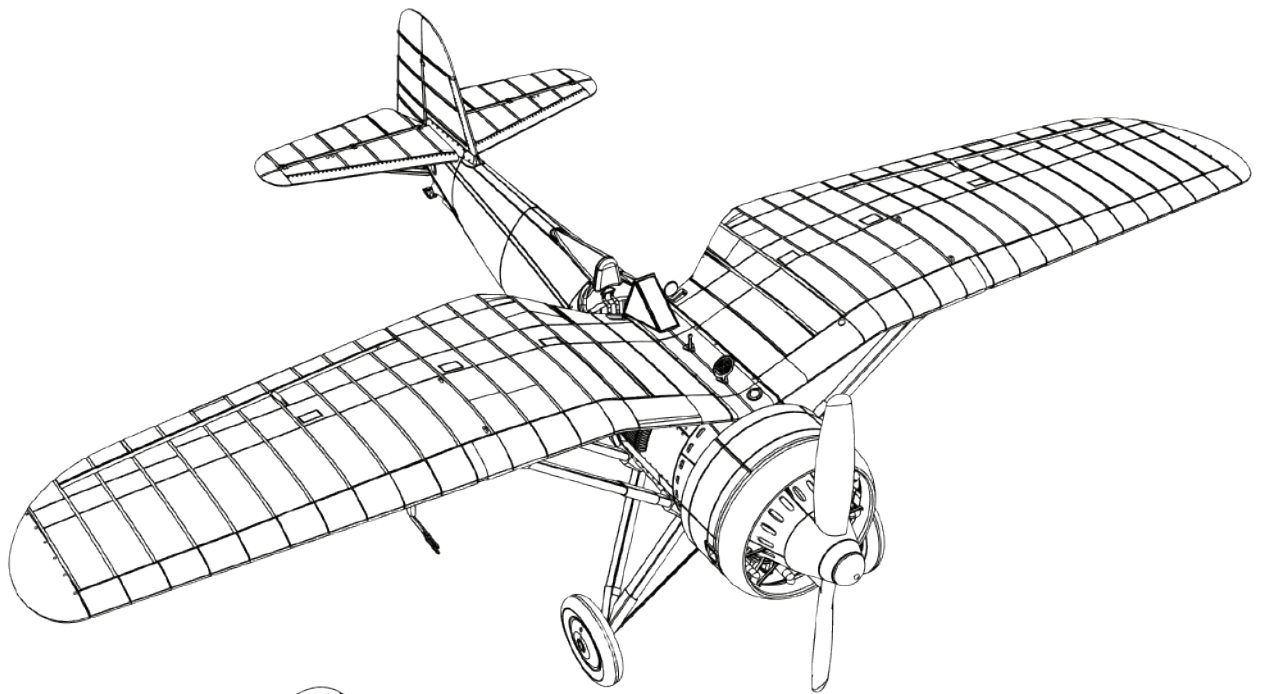
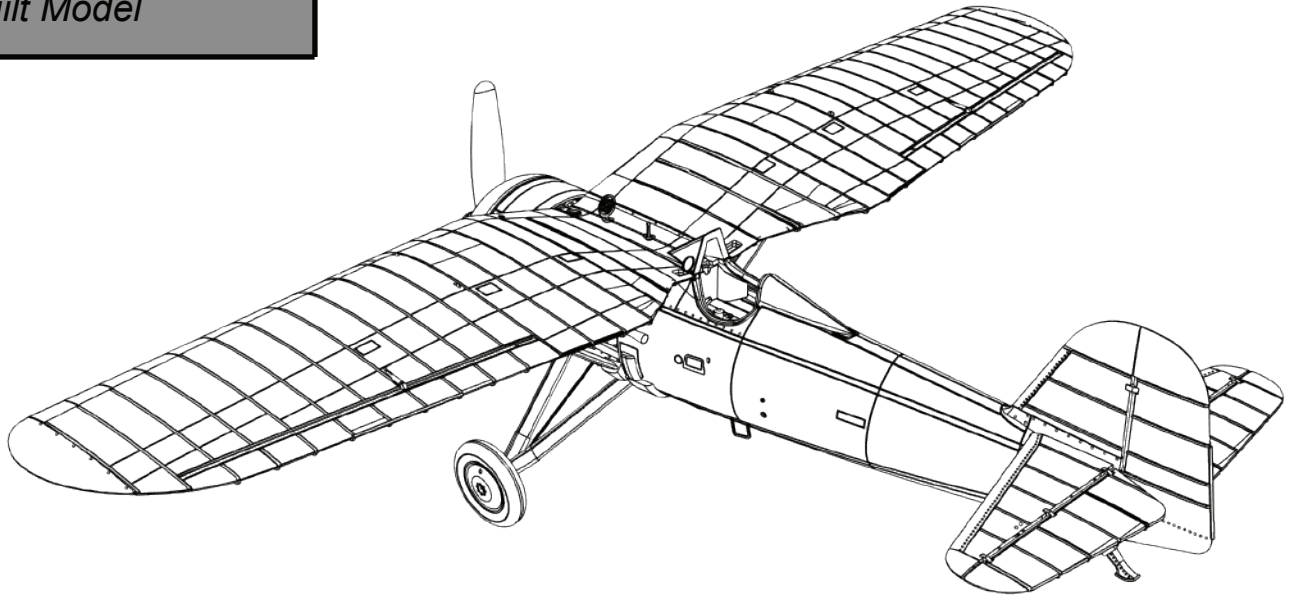



# ALSO AVAILABLE FROM IBG MODELS

1:72  
72512

IBG MODELS



PZL. 37 A bis I  
Polish Medium Bomber

This image shows a detailed model of a PZL. 37 A bis I Polish Medium Bomber. The aircraft is a twin-engine, high-wing monoplane with a large fuselage and a prominent nose section. It is shown on a runway at dusk or dawn, with the sun low on the horizon, creating a soft glow and long shadows. The aircraft has a dark paint scheme with red and white markings on the wings and tail. The background shows a misty or hazy atmosphere over the runway.

1:72  
72507

IBG MODELS



PZL-23B Karaś  
Polish Light Bomber (Late)

This image shows a PZL-23B Karaś Polish Light Bomber in flight. The aircraft is a single-engine, low-wing monoplane with a rounded fuselage and a large, rounded nose. It is shown in a steep climb, banking to the right. The background is a blurred landscape of green fields and trees, suggesting high speed. The aircraft has a dark paint scheme with a white cross on the tail.

1:72  
72517

IBG MODELS



PZL. P.11A  
Polish Fighter

This image shows a PZL. P.11A Polish Fighter in flight. The aircraft is a single-engine, high-wing monoplane with a large, rounded fuselage and a prominent nose. It is shown in a steep climb, banking to the right. The background is a blurred landscape of green fields and trees, suggesting high speed. The aircraft has a dark paint scheme with a white cross on the tail.

1:72  
72527

IBG MODELS



RWD-8 DWL in Palestine (Israeli Service)

This image shows an RWD-8 DWL biplane on the ground. The aircraft is a two-engine, high-wing biplane with a large, rounded fuselage and a prominent nose. It is shown on a dirt airfield. The background is a blurred landscape of green fields and trees, suggesting a rural setting. The aircraft has a dark paint scheme with a white cross on the tail.

1:72  
72510

IBG MODELS



PZL. 23 B Karaś  
Polish Light Bomber in Romanian Service

This image shows a PZL. 23 B Karaś Polish Light Bomber in flight. The aircraft is a single-engine, low-wing monoplane with a rounded fuselage and a large, rounded nose. It is shown in a steep climb, banking to the right. The background is a blurred landscape of green fields and trees, suggesting high speed. The aircraft has a dark paint scheme with a white cross on the tail.

1:72  
72511

IBG MODELS



PZL 37A ŁOŚ - Polish Medium Bomber

This image shows a PZL 37A ŁOŚ Polish Medium Bomber in flight. The aircraft is a twin-engine, high-wing monoplane with a large fuselage and a prominent nose section. It is shown in a steep climb, banking to the right. The background is a blurred landscape of green fields and trees, suggesting high speed. The aircraft has a dark paint scheme with a white cross on the tail.

September Sky 1939  
2 in 1: PZL P.11a and PZL 37B Łoś

IBG MODELS



1:72  
72528

This image shows two aircraft in flight. The foreground aircraft is a PZL 37B Łoś, a twin-engine, high-wing monoplane with a large fuselage and a prominent nose section. The background aircraft is a PZL P.11a, a single-engine, high-wing monoplane with a large, rounded fuselage and a prominent nose. Both aircraft are shown in a steep climb, banking to the right. The background is a blurred landscape of green fields and trees, suggesting high speed. The aircraft have dark paint schemes with white crosses on their tails.



**Malowanie**  
Painting

**PZL P.11b nr 23, Școala de Perfecționare, lato 1940**  
*PZL P.11b no.23, Școala de Perfecționare, summer 1940*

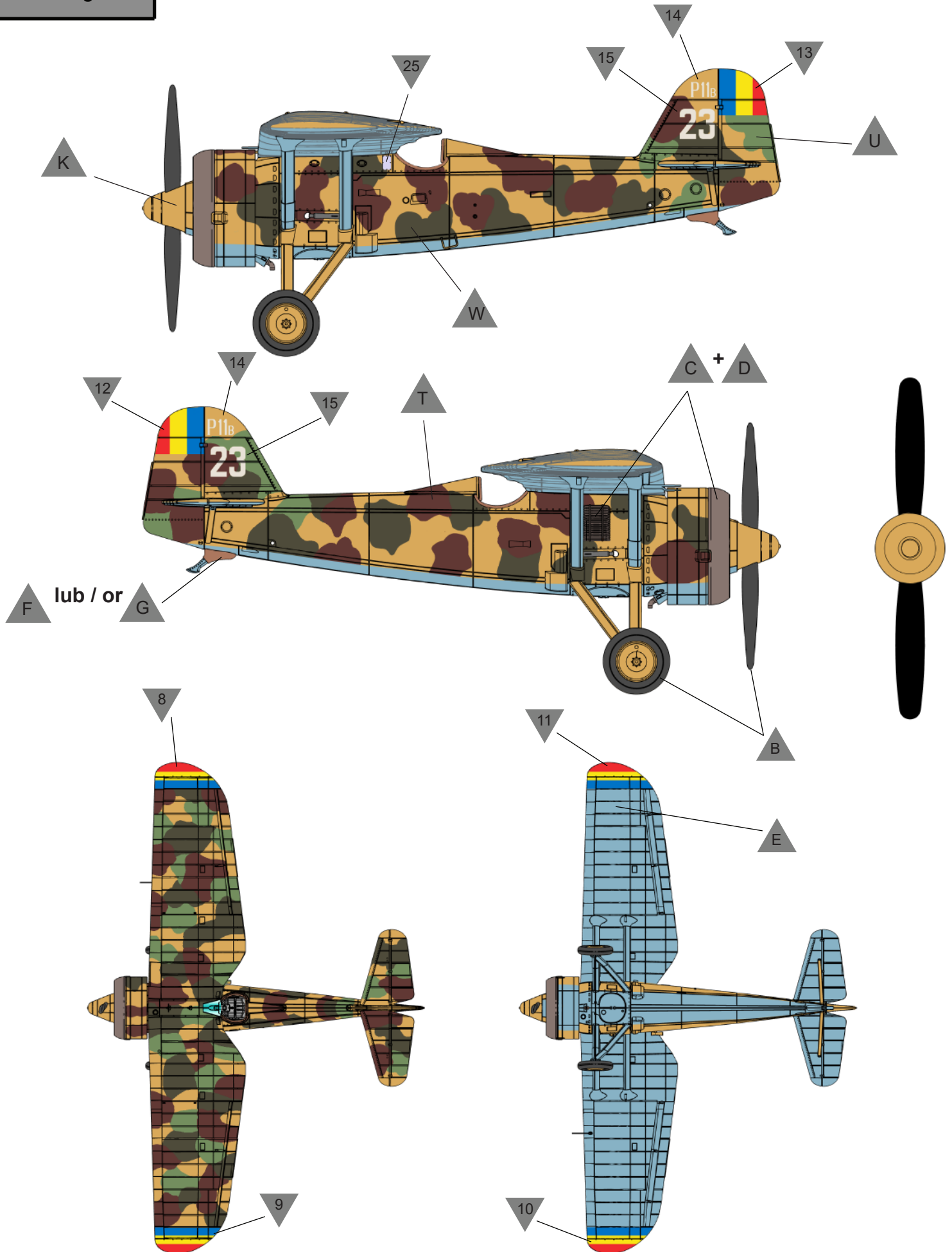

**Note:**  
In our analysis we have put every effort possible into proper identification of colours. Our camouflage color reconstruction is based on the fact, that Romania imported aircraft paints from Italy at the time.



**Malowanie**  
*Painting*

**PZL P.11b nr 25, lotnisko Târgșoru Nou w okolicach Ploești, lato 1941**  
*PZL P.11b no.25, Târgșoru Nou airfield near Ploești, summer 1941*

