



AR-2 (43105)

1/35 SCALE MODEL KIT No 35003

AR-2 (43105), Пожежний рукавний автомобіль

Спеціальний пожежний рукавний автомобіль AR-2 (43105) призначений для механізованого прокладання пожежних рукавних ліній від до місця пожежі. Випуск автомобіля розпочався у 1989 році. На спеціально підготовленому шасі розміщено суцільнометалевий кузов, який має бічні і задні двері. Всередині кузов розділено на два відсіки, в передньому розміщується протипожежне обладнання, в задньому вкладаються пожежні рукави. У кузові також знаходяться спеціальні стійки, що можуть утворювати секції різного розміру. Екіпаж автомобіля складається із водія та двох операторів, до завдань першого оператора входить управління механізмом збирання пожежних рукавів, другий оператор спостерігає за їхнім прокладанням і контролює укладання у кузов після використання. Довжина такої рукавної лінії може сягати понад 2,5 кілометри. Деяка частина таких автомобілів продовжує експлуатуватися в пожежних частинах і в даний момент.

Тактико-технічні характеристики AR-2 (43105)

Повна маса, кг	14530
Довжина, мм	8840
Ширина, мм	2500
Висота, мм	3530
Максимальна швидкість, км/год	85
Екіпаж (бойовий розрахунок), чел.	3

AR-2 (43105), Hose fire truck

The special fire hose truck AR-2 (43105) is designed for mechanised laying of fire hose lines from the fire site. Production of the vehicle began in 1989. The vehicle was based on the off-road KAMAZ-43105, which has proven itself. A specially prepared chassis is fitted with an all-metal body with side and rear doors. Inside, the body is divided into two compartments, the front one houses fire-fighting equipment, and the rear one holds fire hoses. The body also has special racks that can form sections of different sizes. The crew of the vehicle consists of a driver and two operators; the first operator is responsible for controlling the fire hose assembly mechanism, while the second operator monitors the laying of the hoses and controls their placement in the body after use. The length of such a hose line can be over 2.5 kilometres. Some of these vehicles are still in use in fire stations today.

Tactical and Technical Specifications of AR-2 (43105)

Full weight, kg	14530
Length, mm	8840
Width, mm	2500
Height, mm	3530
Max. Speed, km/h	85
Crew (combat team), men	3

ФАРБИ, ЩО ВИКОРИСТОВУЮТЬСЯ / USED COLORS:

COLOR	ICM
A Червоний Deep Red	1007
B Небесно-сіра Sky Gray	1033
C Чорний Black	1002
D Гумовий чорний Rubber Black	1039
E Сталь Natural Steel	1025
F Срібло Silver	1024
G Алюміній Aluminium	1023
H Нейтральний сірий Neutral Grey	1036
J Темна іржа Dark rust	1051
K Напівпрозорий червоний Clear Red	1011
L Напівпрозорий помаранчевий Clear Orange	1016
M Напівпрозорий синій Clear Blue	1012
N Білий White	1001



Використовуйте набір фарб від ICM
Best to be used with ICM Paint Set

Для отримання глянцевого, сатинового чи матового ефекту – використовуйте наші лаки!

For a glossy, satin or matte effect - use our varnishes!

2001 МАТОВИЙ ЛАК VARNISH MATT	2002 САТИНОВИЙ ЛАК VARNISH SATIN	2003 ГЛЯНЦЕВИЙ ЛАК VARNISH GLOSS
-------------------------------------	--	--

01 СТАДІЯ СКЛАДАННЯ
ASSEMBLY STEP

A ФАРБА, ЩО ВИКОРИСТОВУЄТЬСЯ
USED COLOR

x2 ЗРОБИТИ ДВІ ДЕТАЛІ
MAKE 2 PCS

ВІДРІЗАТИ
CUT OFF

03 СКЛАДАЛЬНА ОДИНИЦЯ
ASSEMBLY UNIT

ЗРОБИТИ САМОМУ
SCRATCH BUILD

НЕ КЛЕЇТИ
DO NOT CEMENT

У В А Г А !
Перед складанням уважно прочитати керівництво з монтажу. Кожна деталь пронумерована. Дотримуватися послідовності монтажу. Необхідні робочі інструменти: ніж і напилек для зачистки деталей, гумова стрічка, клеїть стрічка і прищипки для притискання склеюваних деталей. Деталі з пластику очистити в розчині м'якого миючого засобу і висушити на повітрі для того, щоб фарба і перекривні картинки краще прилягали. Перед приклеюванням перевірити, чи підходять деталі; клей наносити економно. Хром і фарбу видалити з поверхонь склеювання. Невеликі деталі пофарбувати перед тим, як вони будуть видалені з рамок. Фарбу необхідно добре просушити, тільки після цього продовжувати складання. Кожну відповідну передвіду картинку вирізати окремо і приблизно на 20 секунд занурити в теплу воду. На позначеному місці картинку відокремити від паперу і притиснути промокальним папером.

С А У Т І О Н !
Read the instructions thoroughly prior to assembly. Each component is numbered. Adhere to specified sequence of assembly. Tools required: knife and file for removal of components from frame; rubber bond, adhesive tape and clothes pegs for clamping components together after applying adhesive. Clean plastic components in a mild detergent solution and allow to air-dry so that paint and transfers adhere better. Prior to applying adhesive, check to see whether the components fit together, apply adhesive sparingly. Remove chrome and paint from the contact surfaces. Paint small components before removing them from the frame. Allow paint to dry well, and only then continue to assemble. Cut out each transfer individually and immerse in warm water for approx. 20 seconds. Slide transfer off paper and into designated position, then press on with blotting paper.

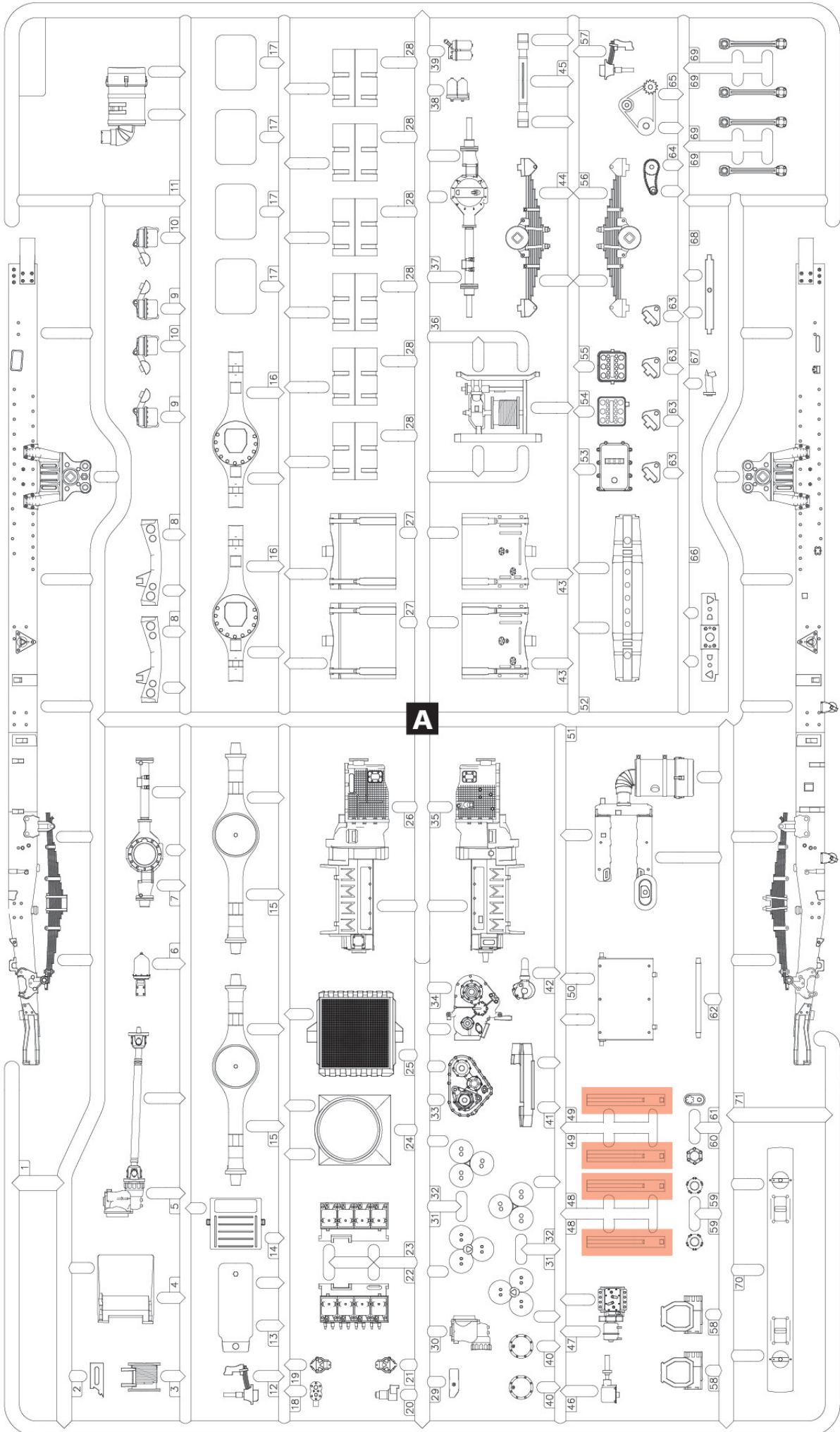

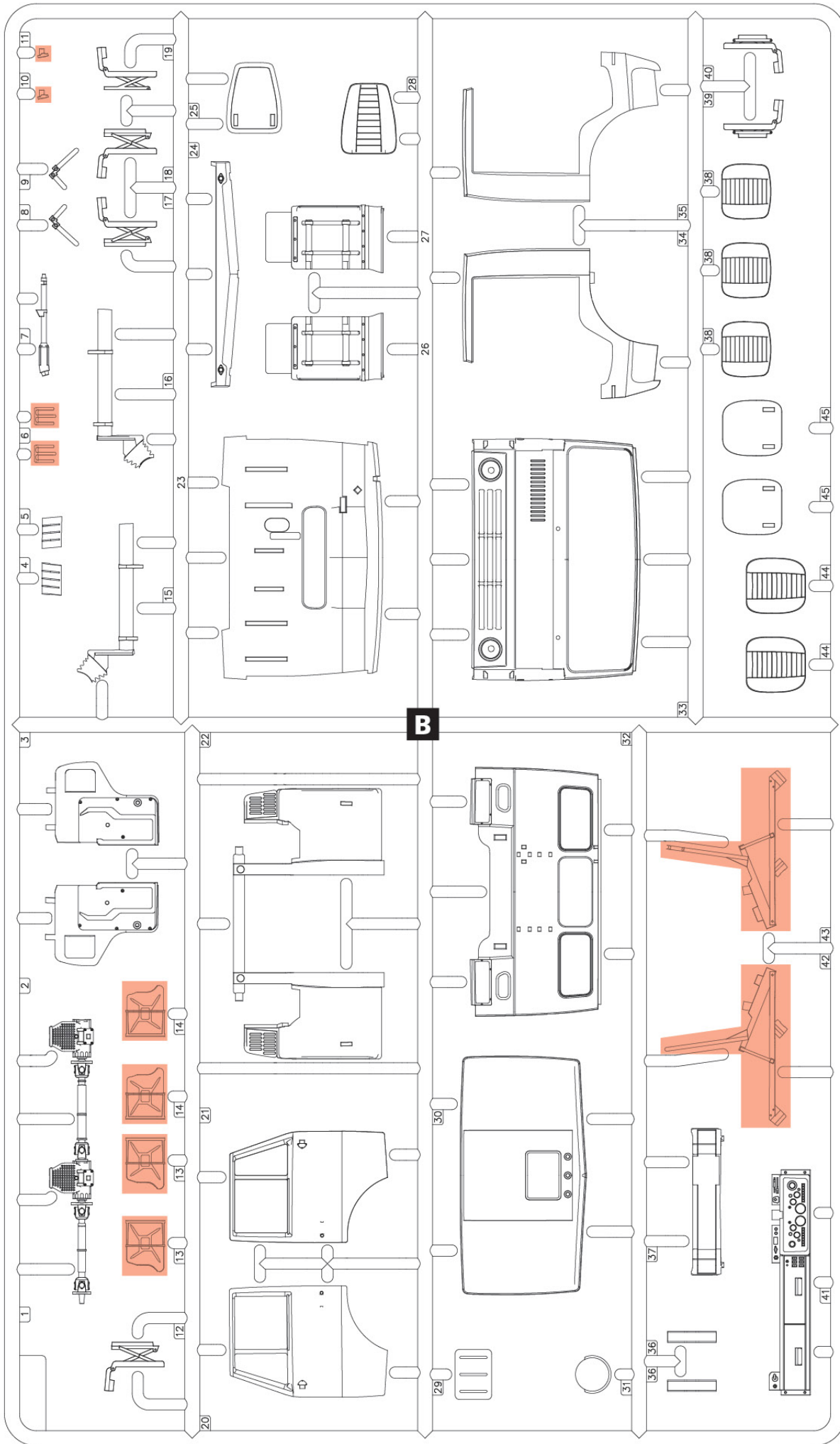

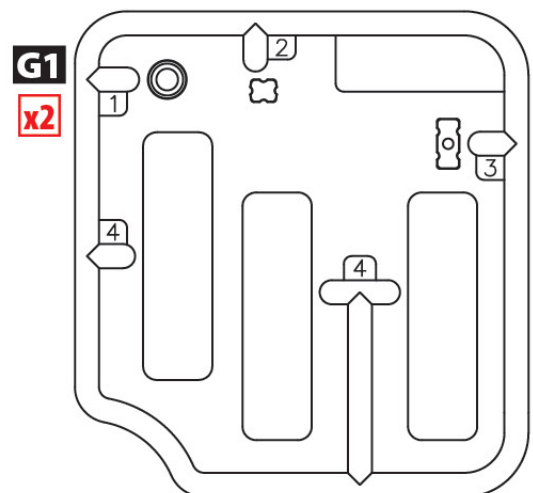
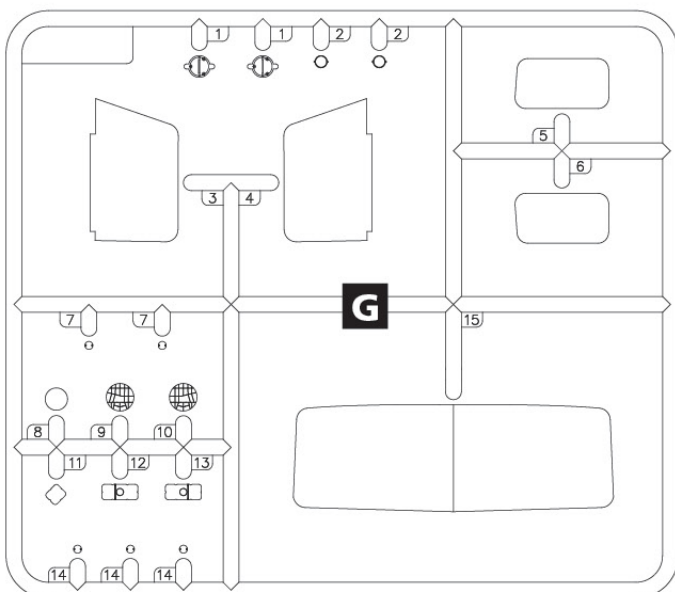
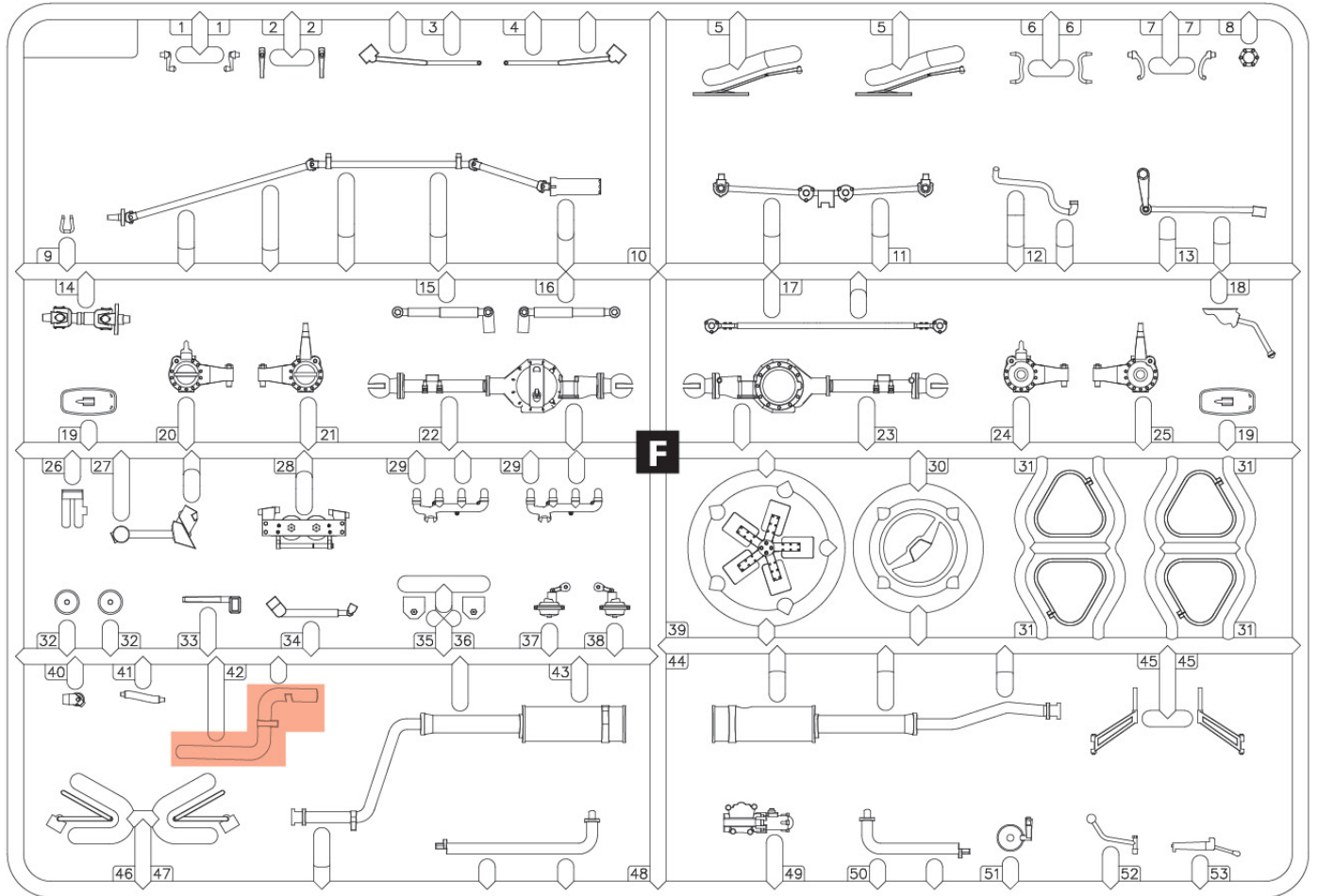
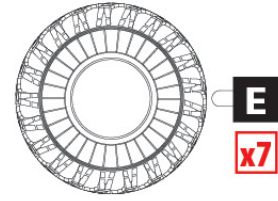
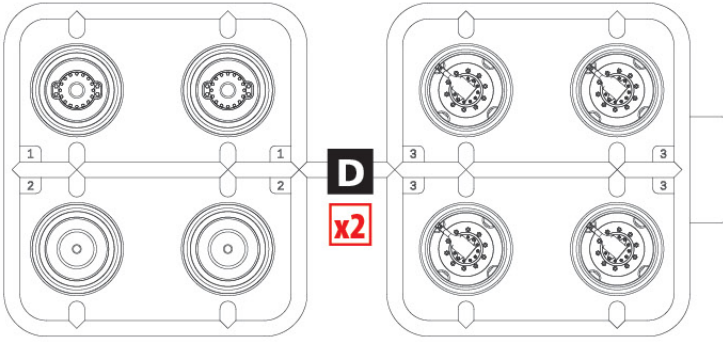

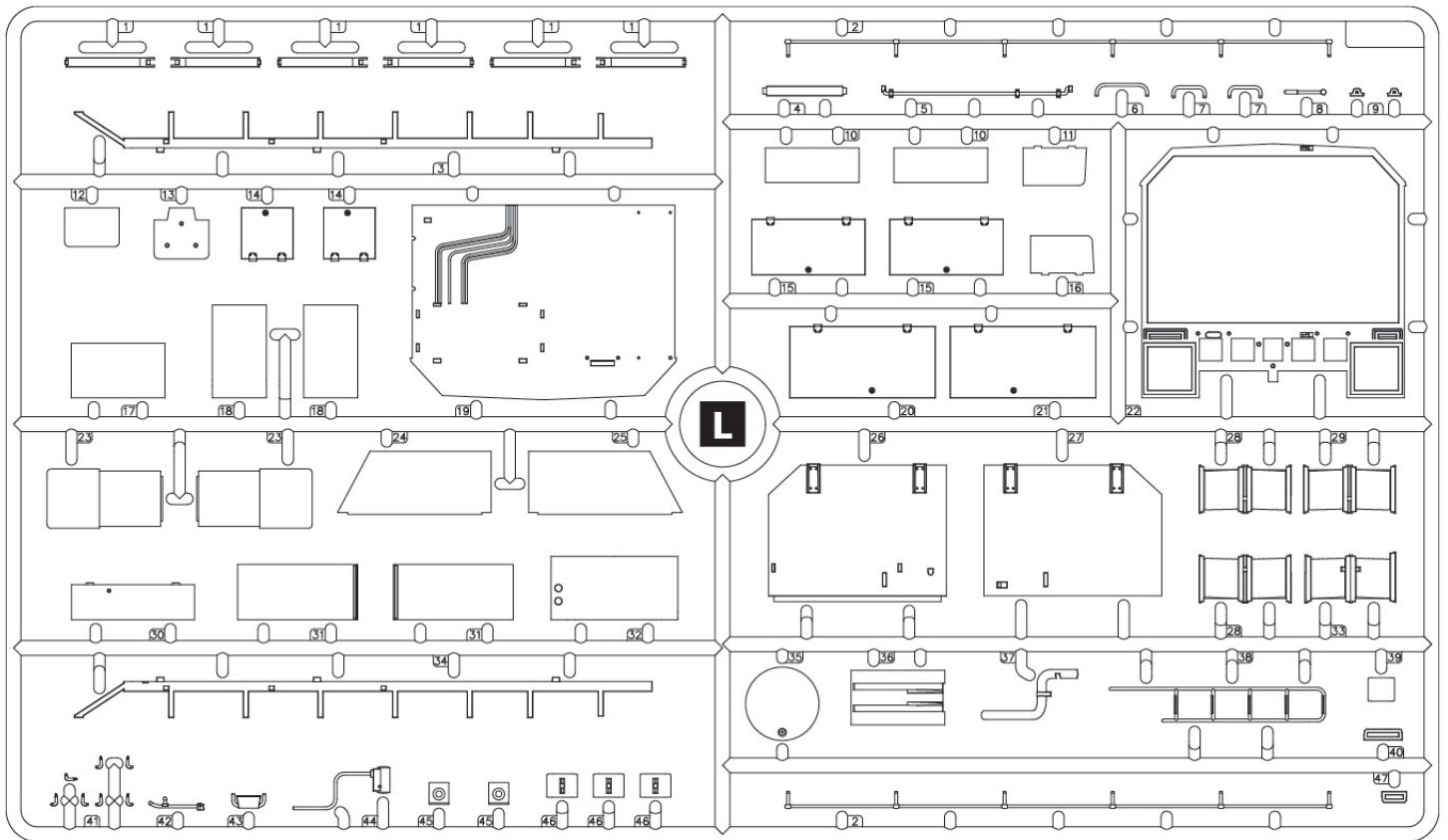
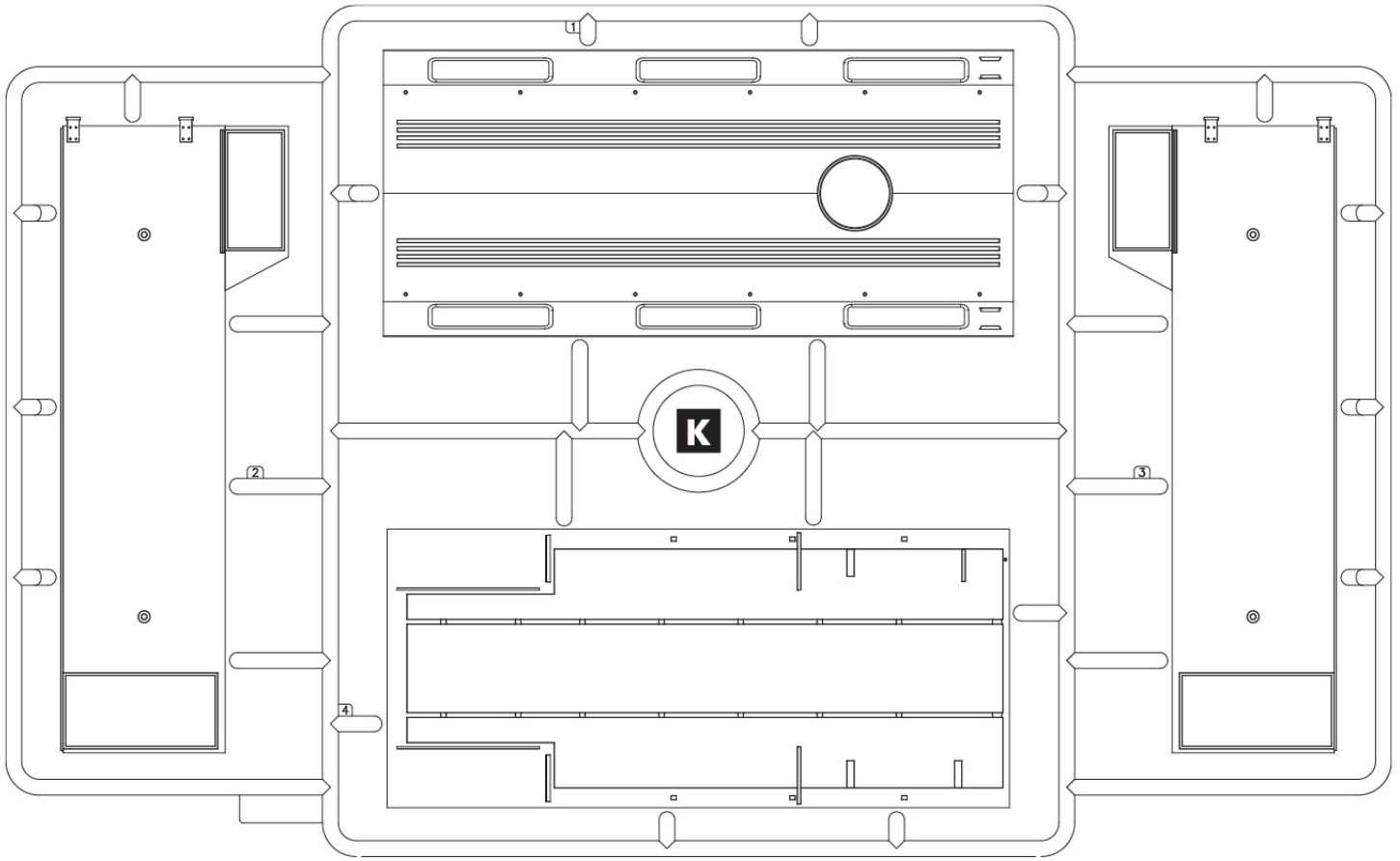

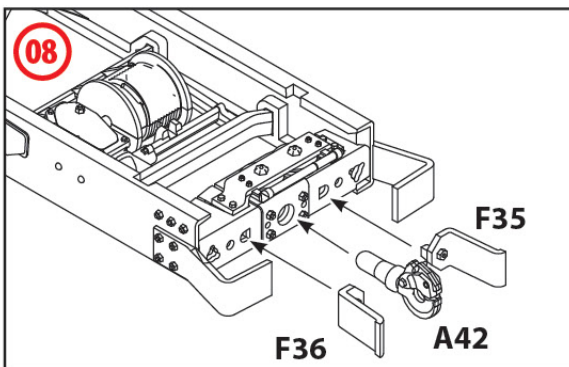
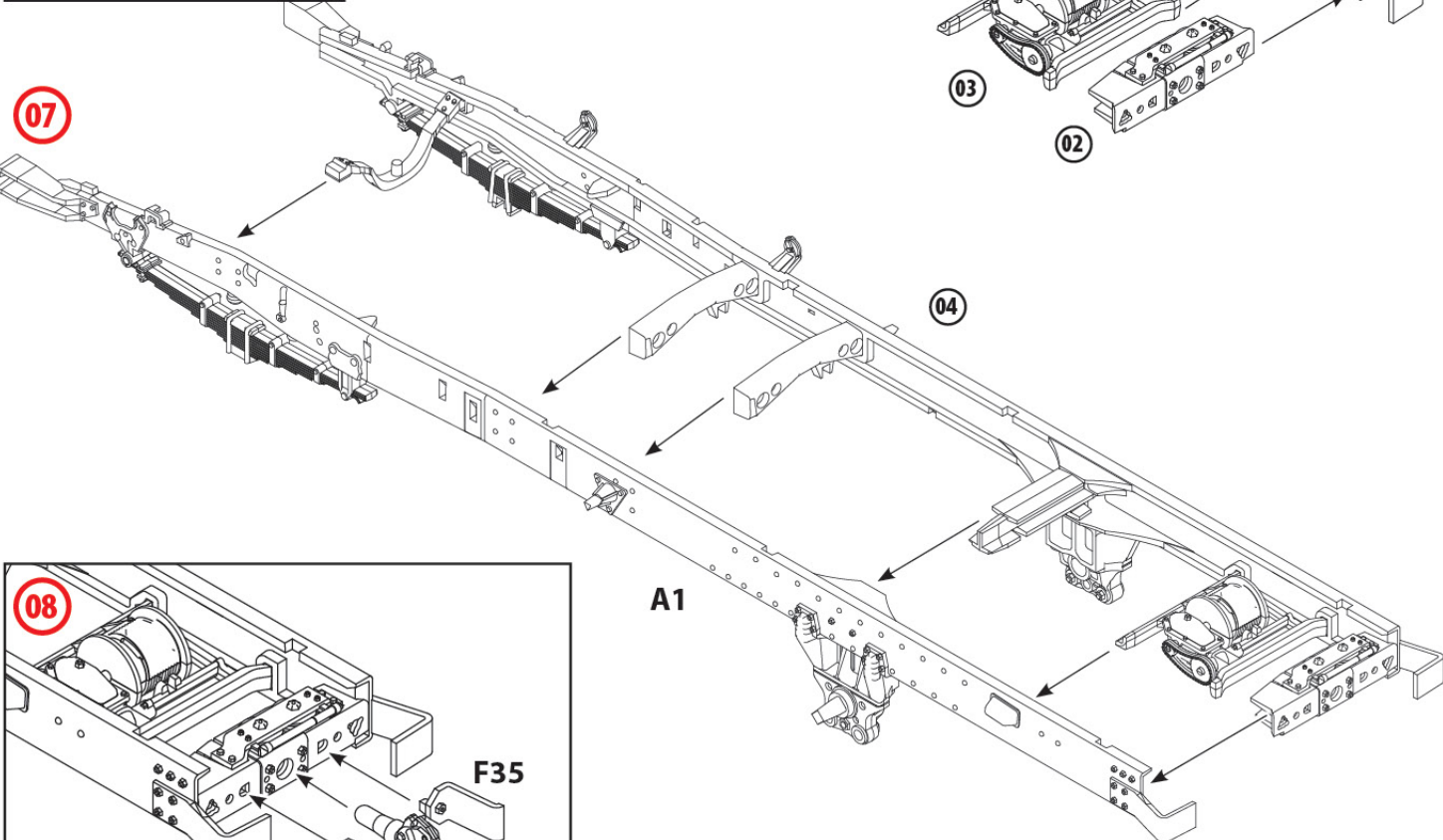
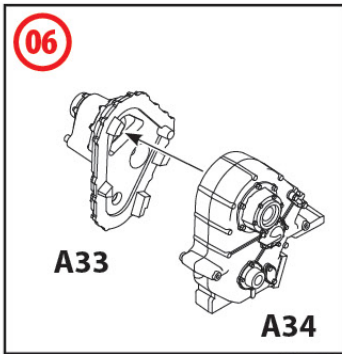
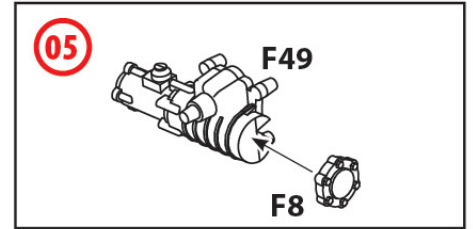
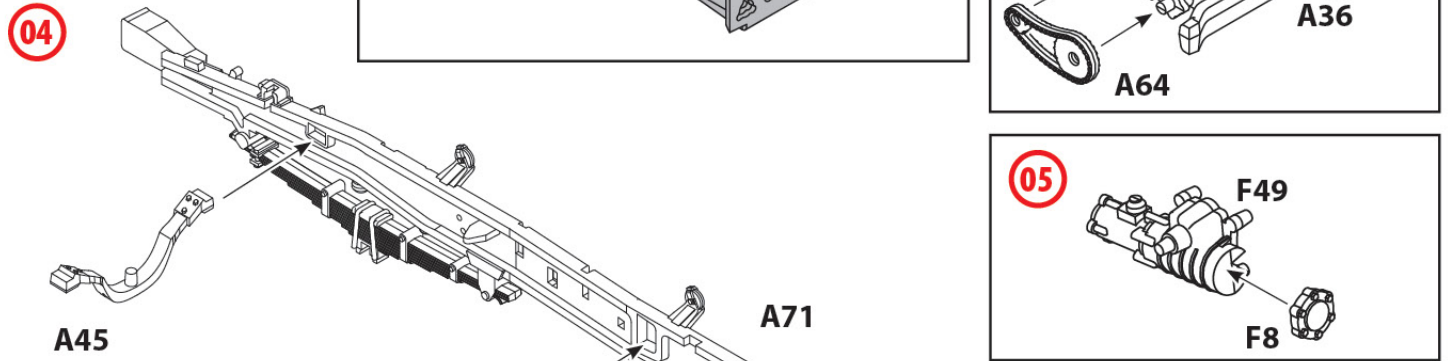
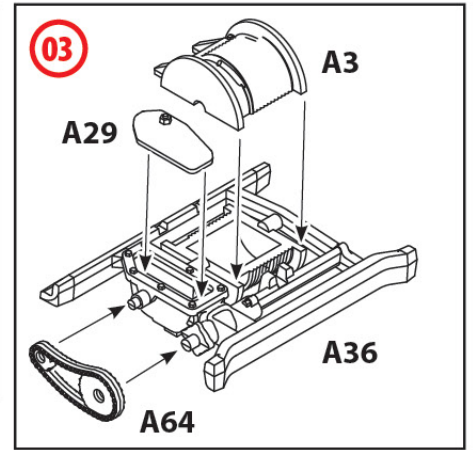
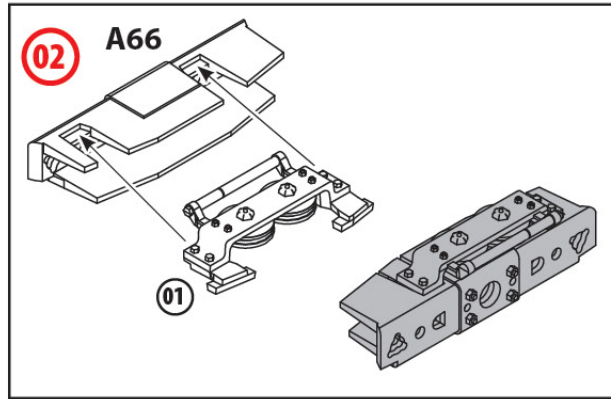
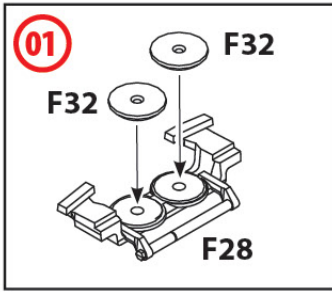

С ВСІ ДЕТАЛІ ШАСІ, КРИМ ЗАЗНАЧЕНИХ ОКРЕМО
 ALL CHASSIS DETAILS EXCEPT MARKED SEPARATELY

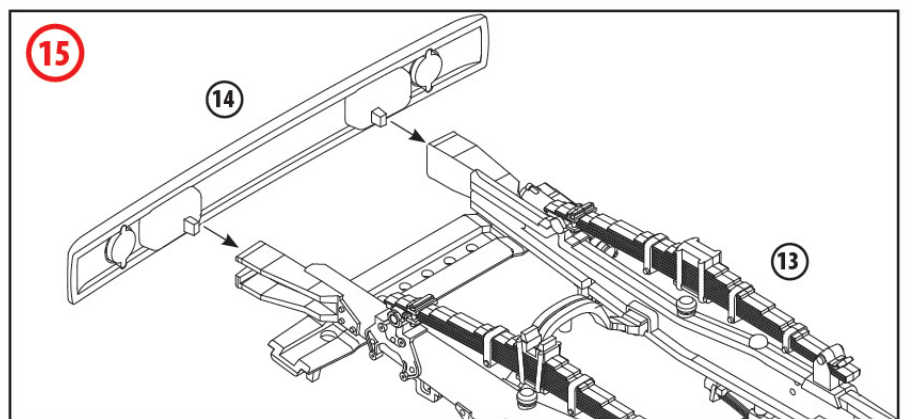
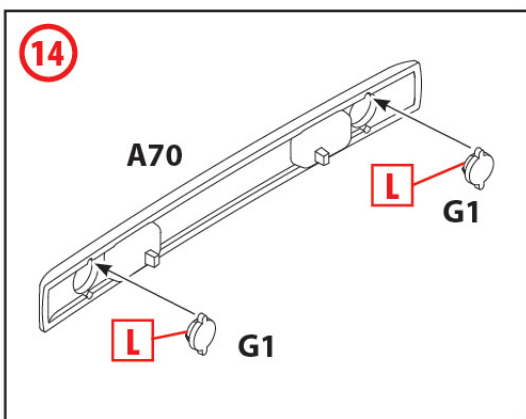
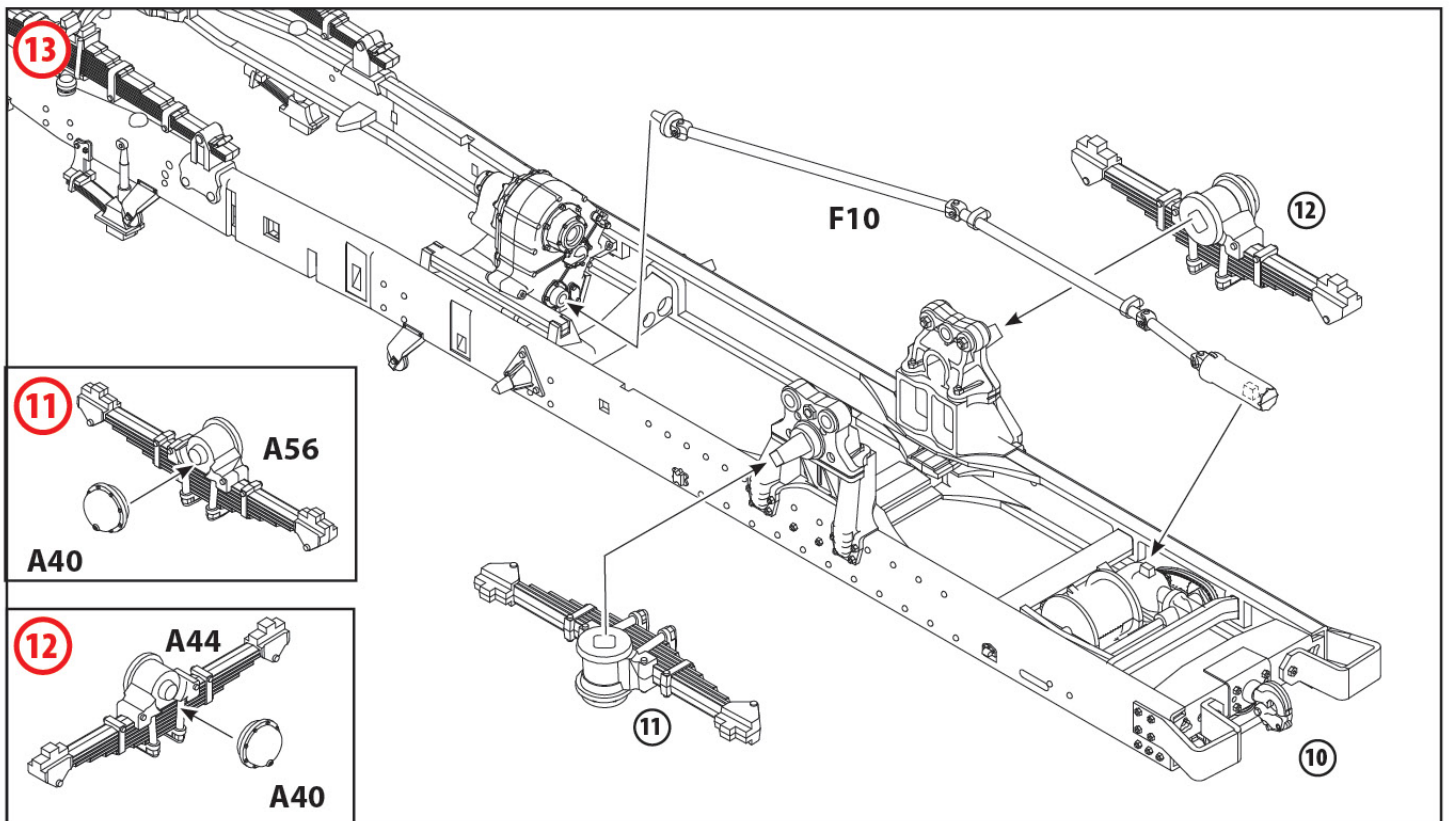
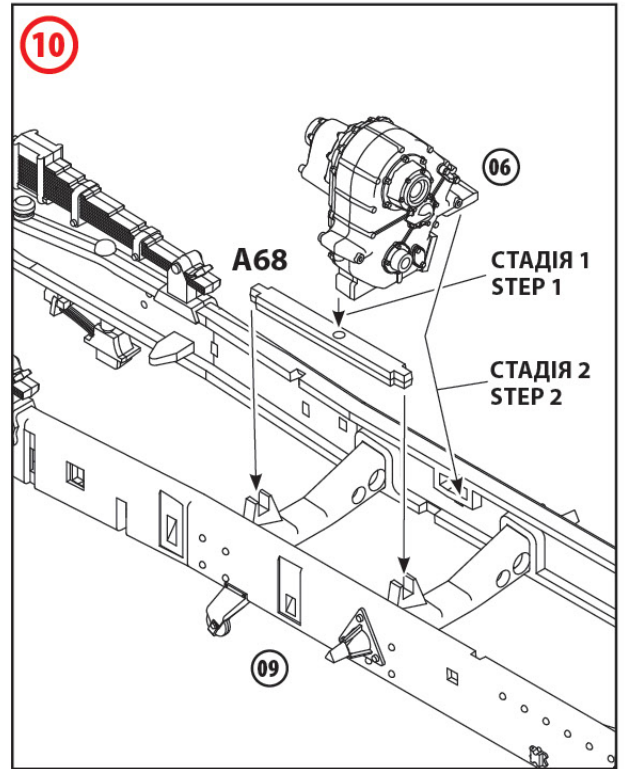
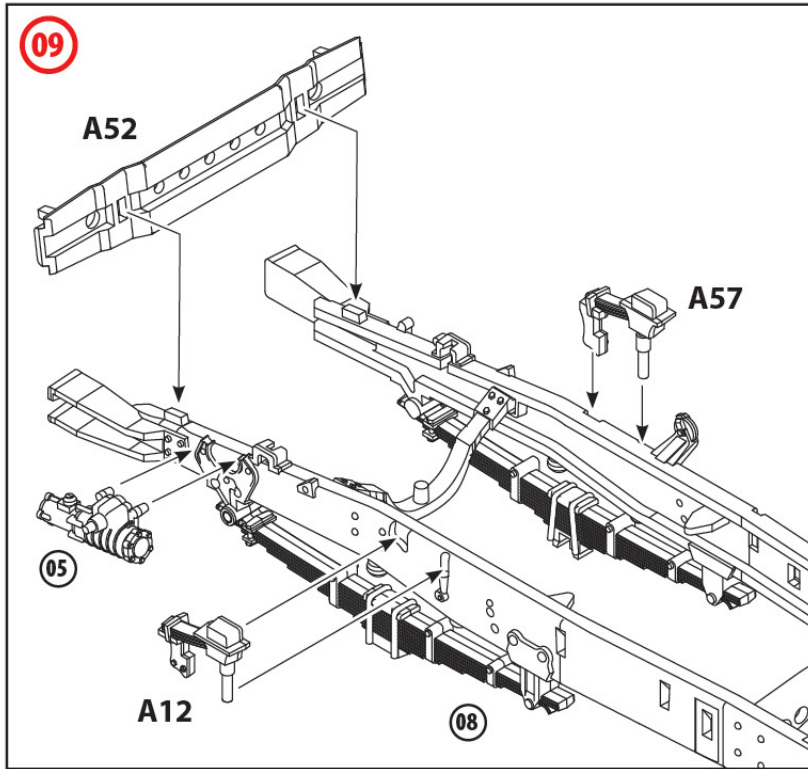

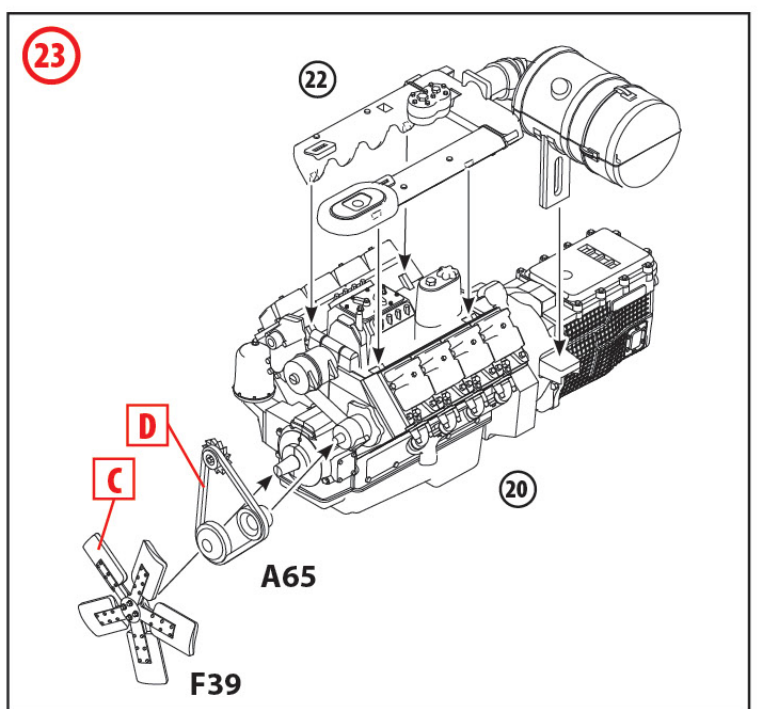
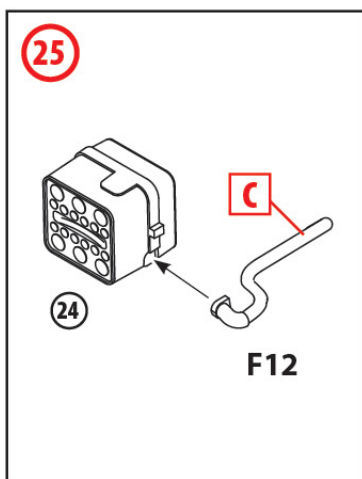
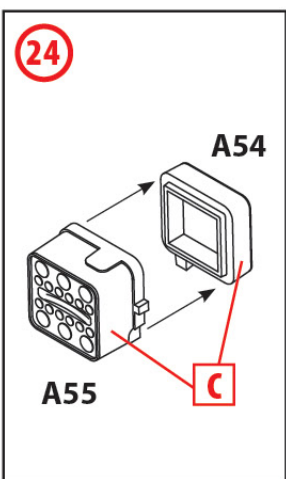
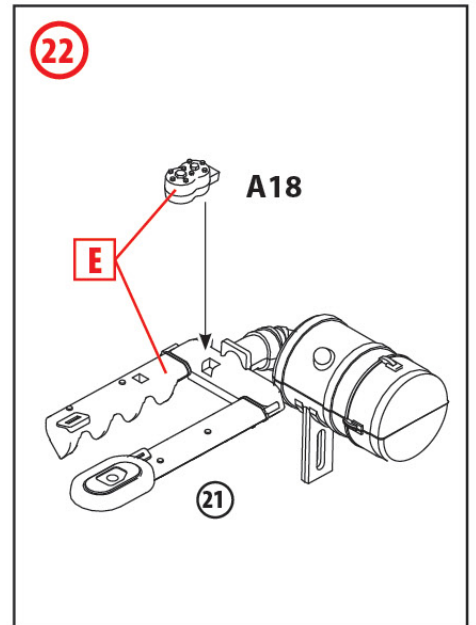
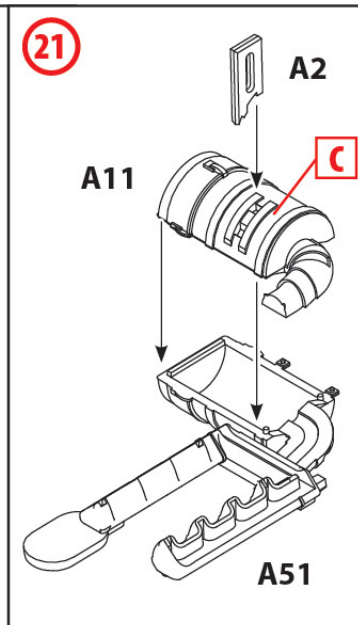
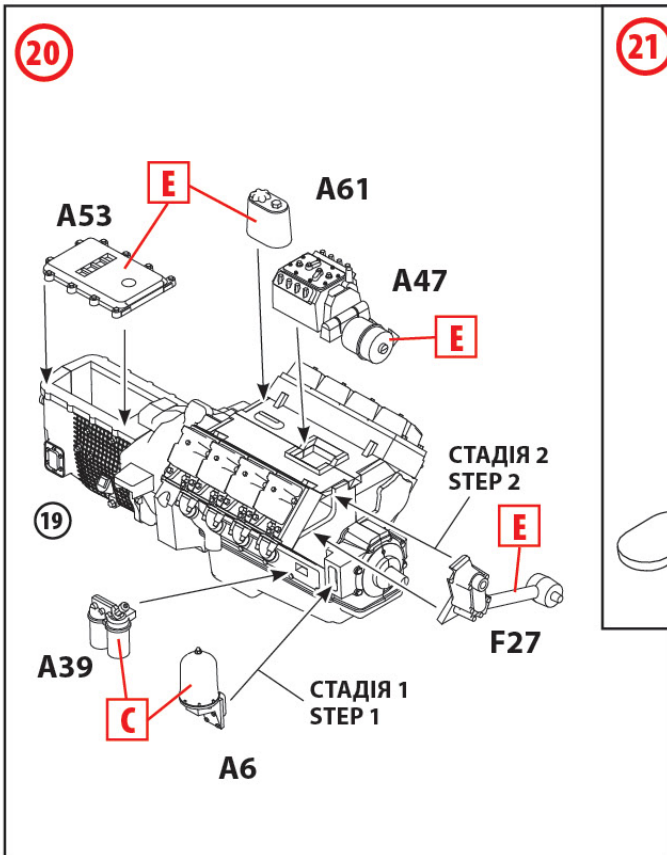
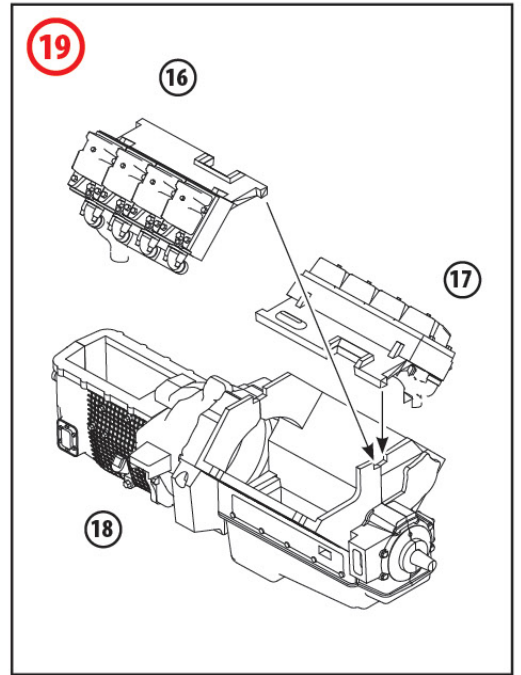
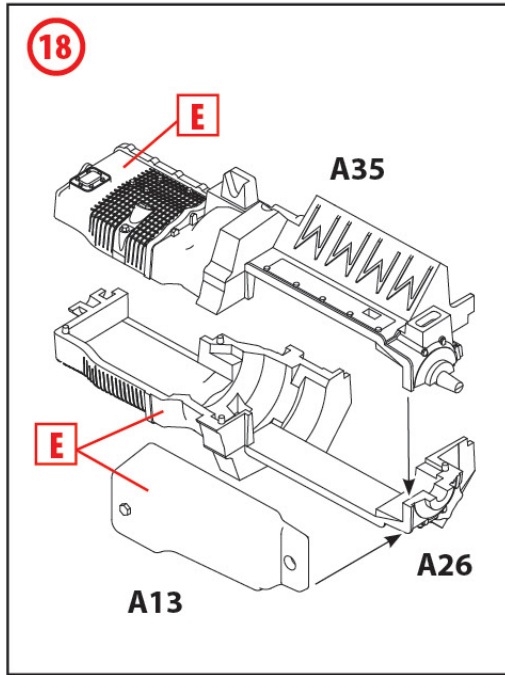
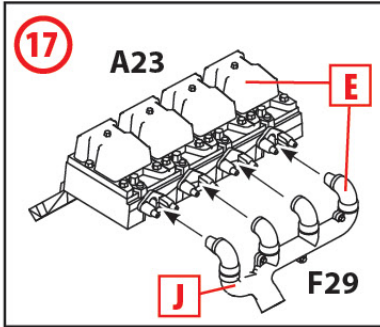
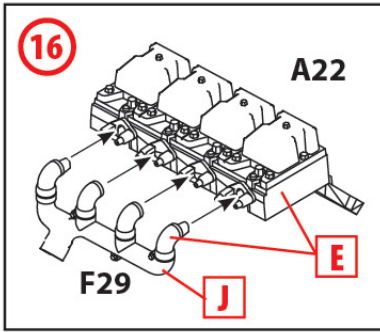

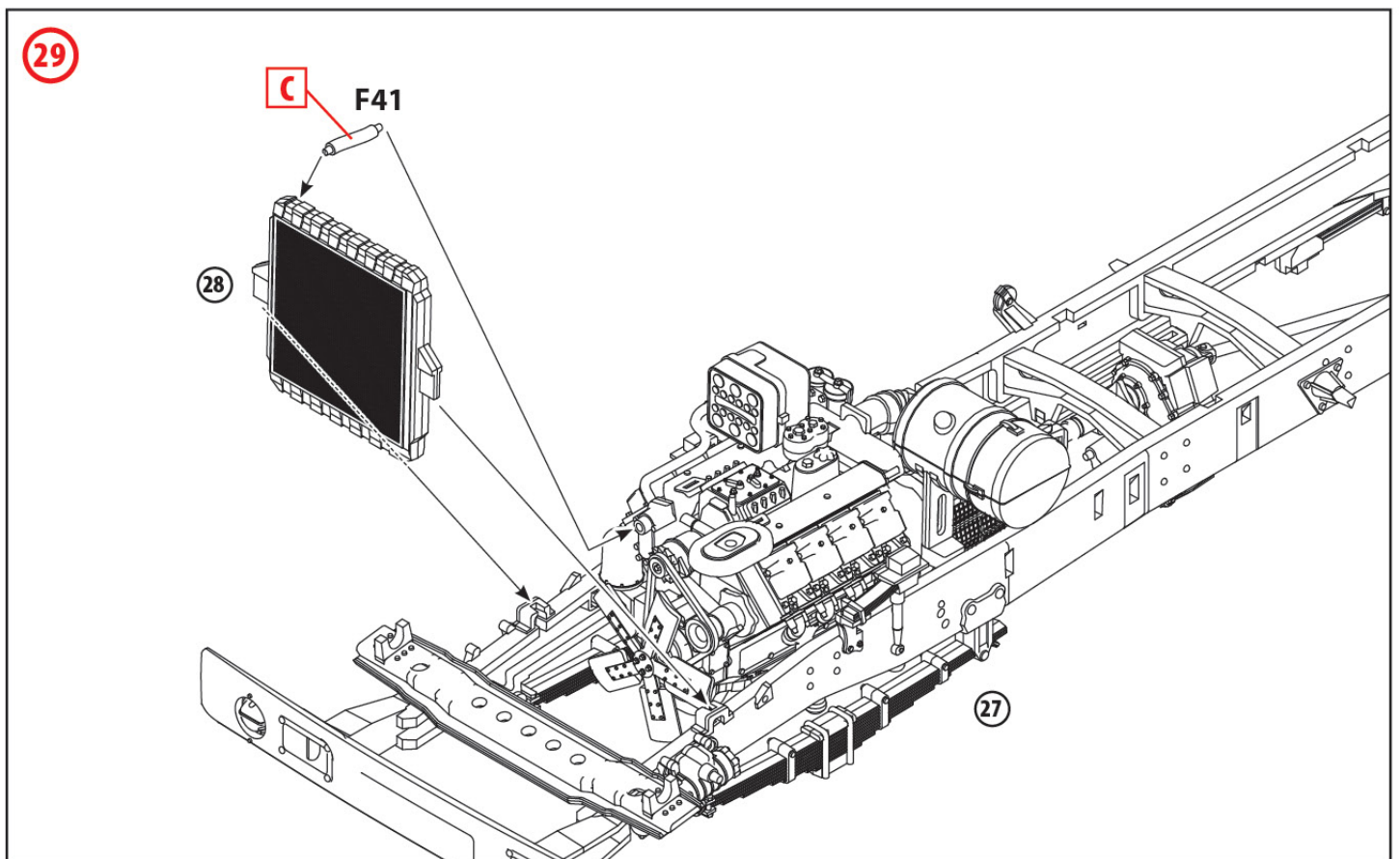
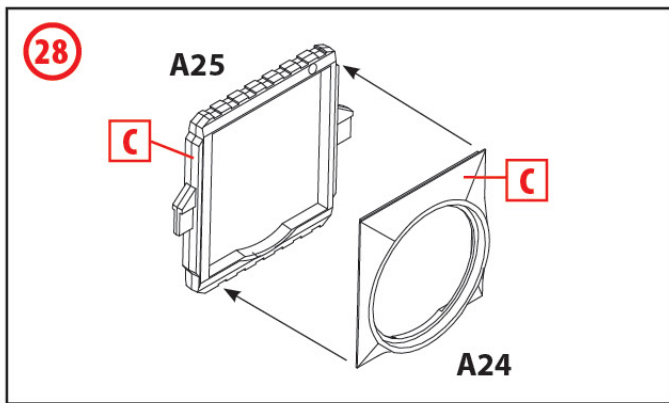
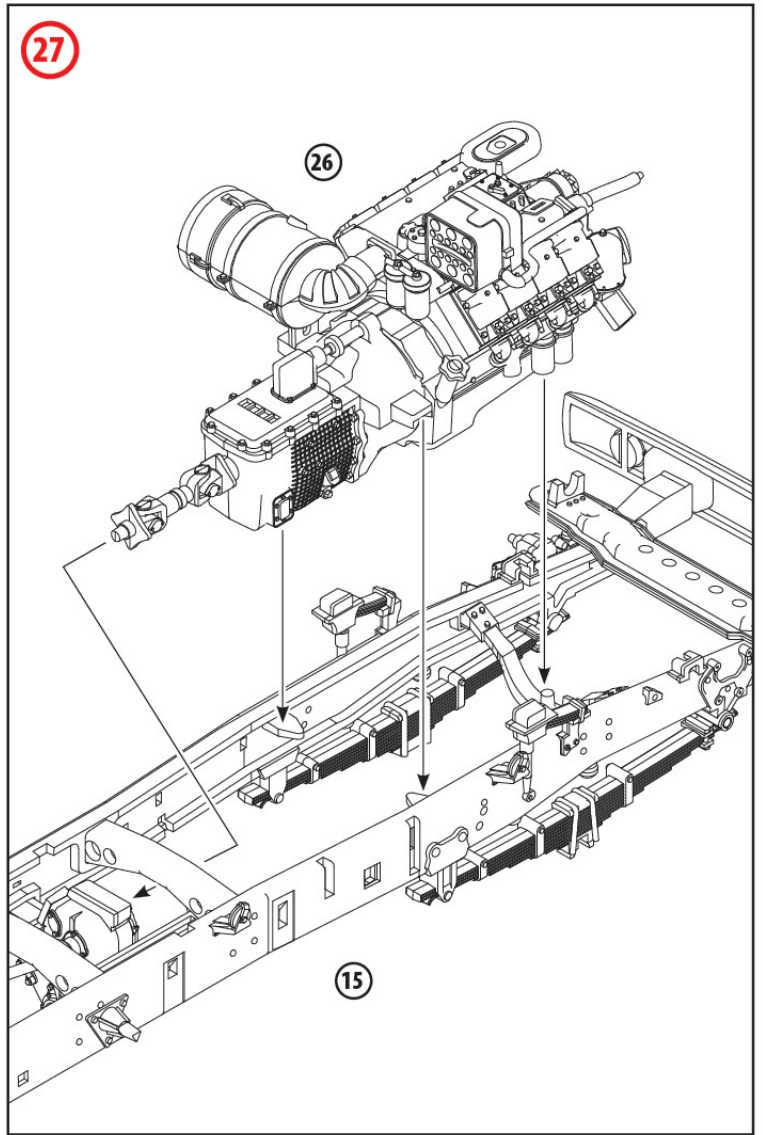
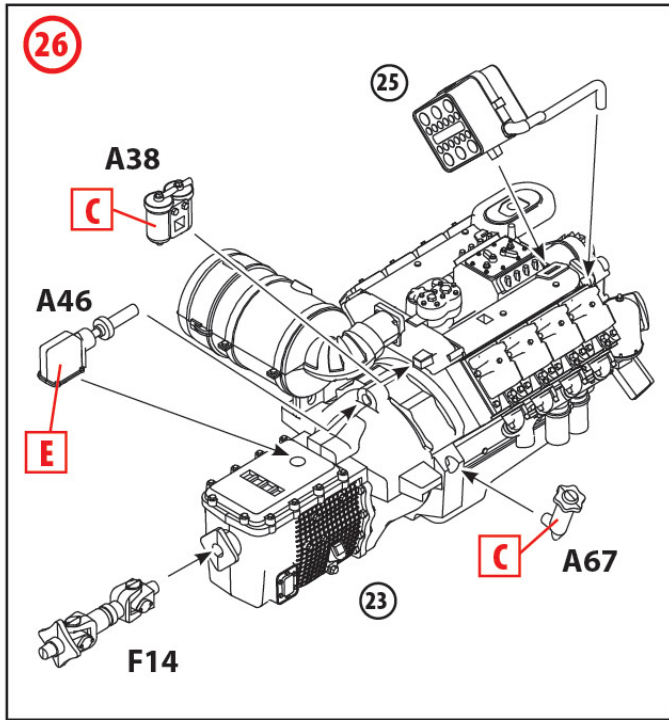

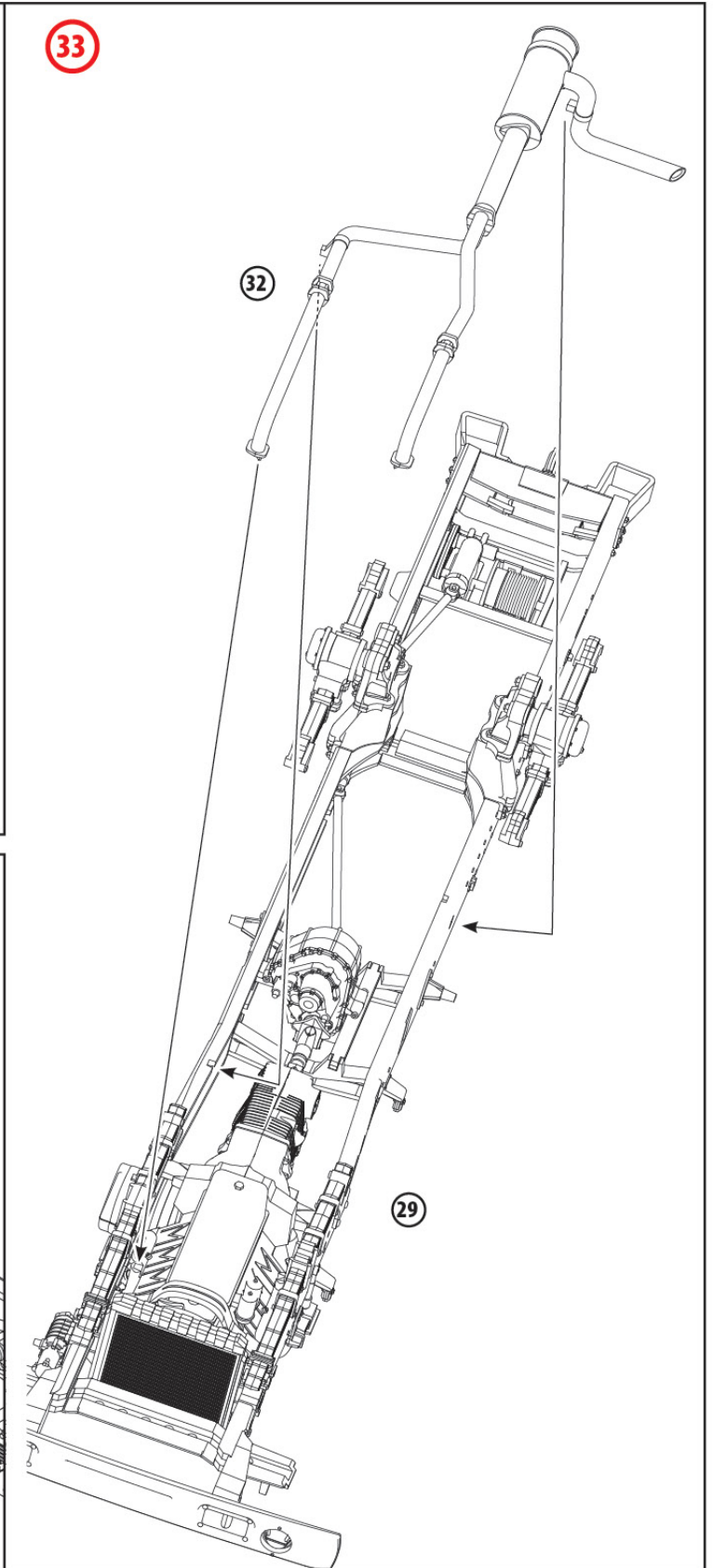
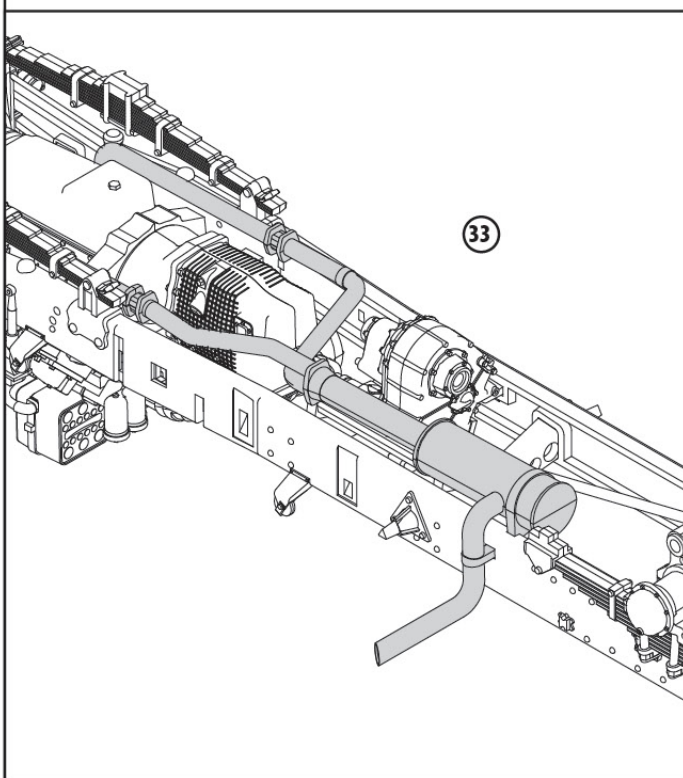
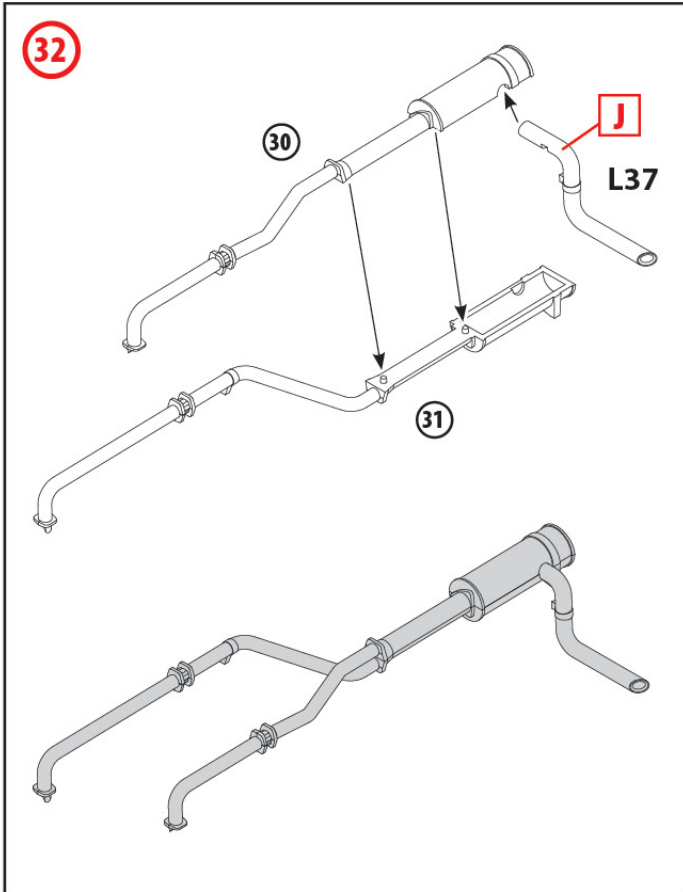
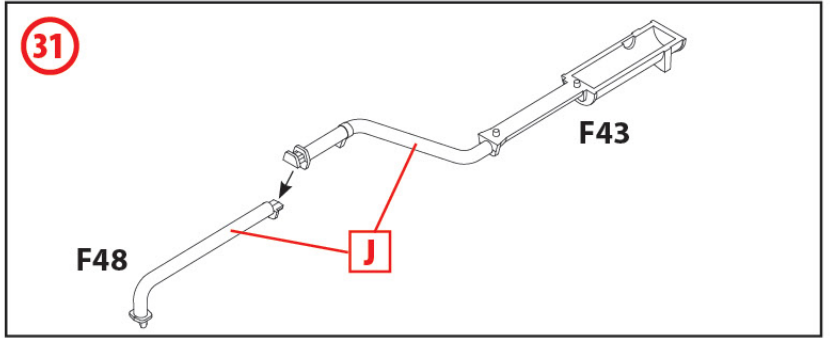
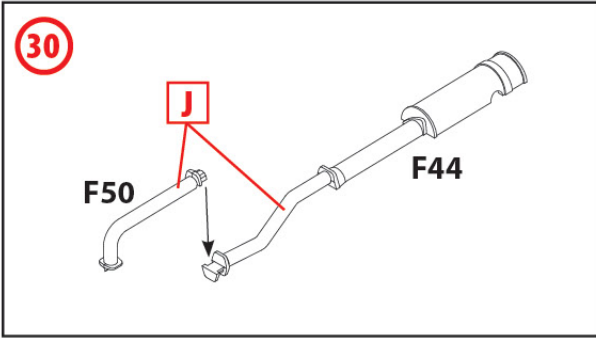

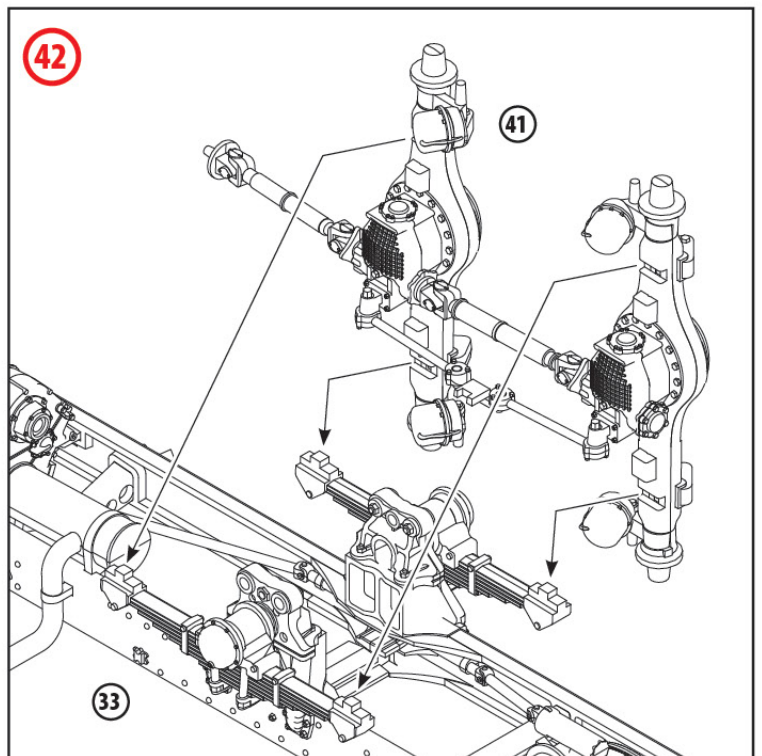
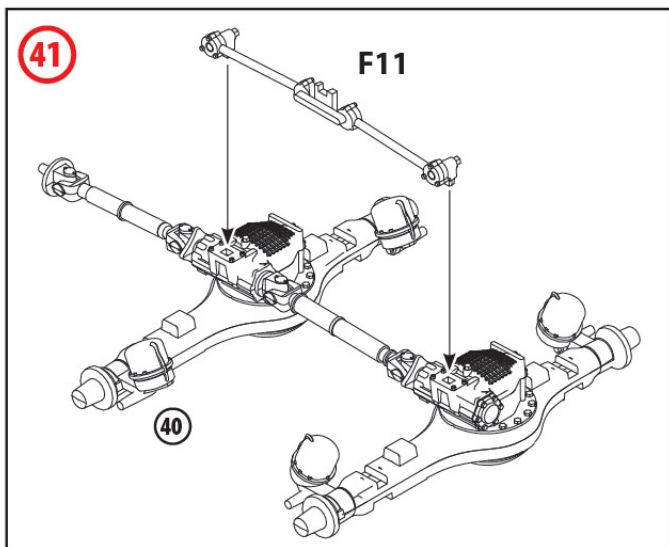
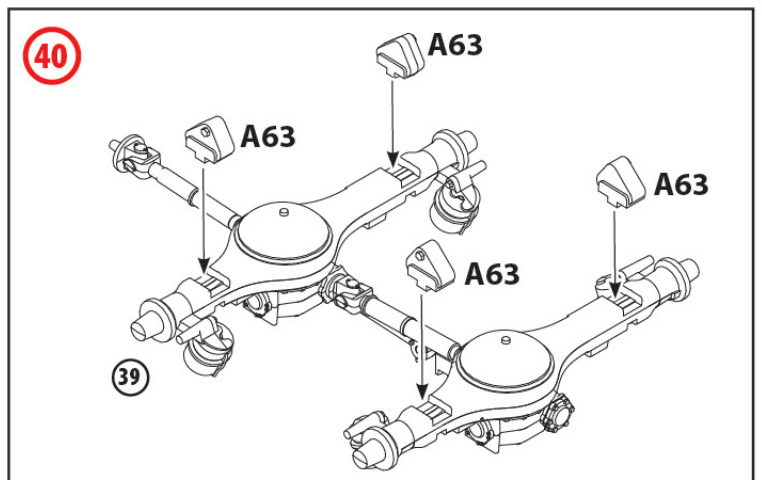
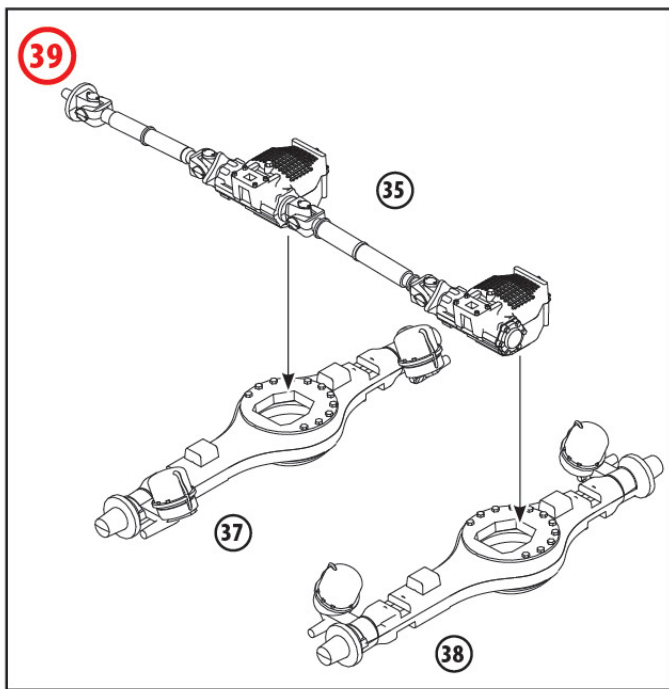
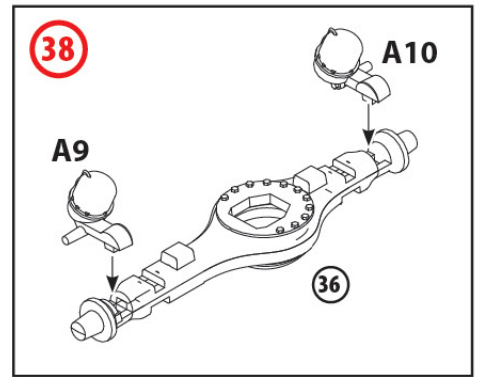
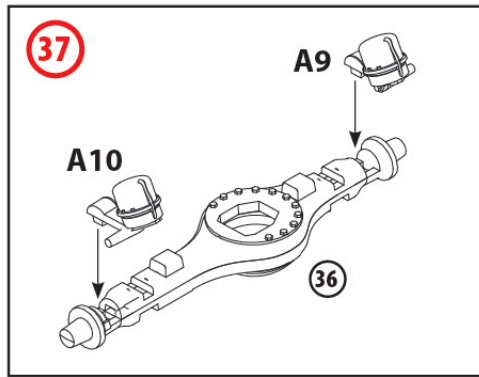
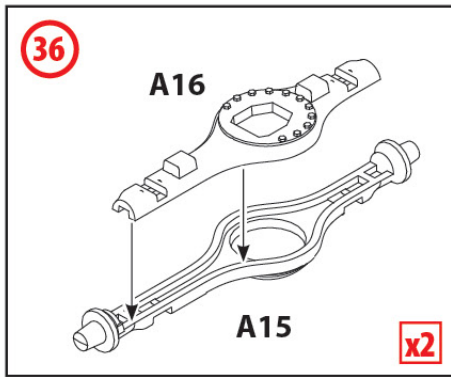
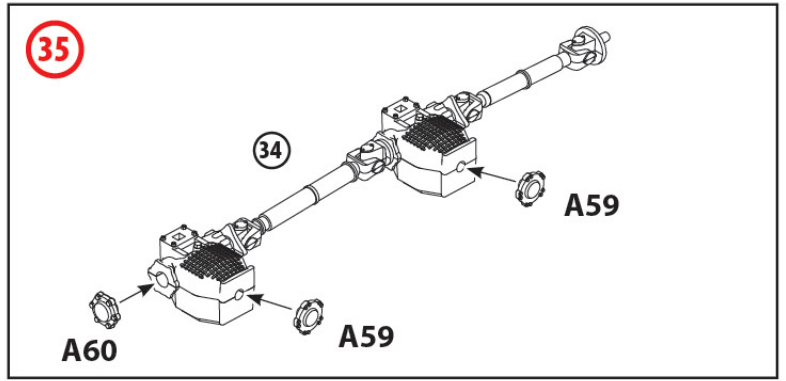
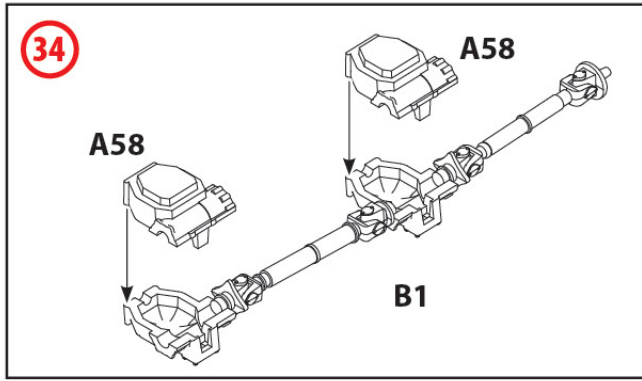

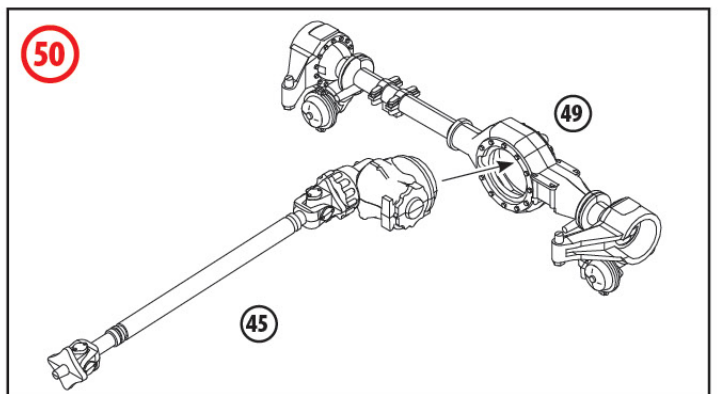
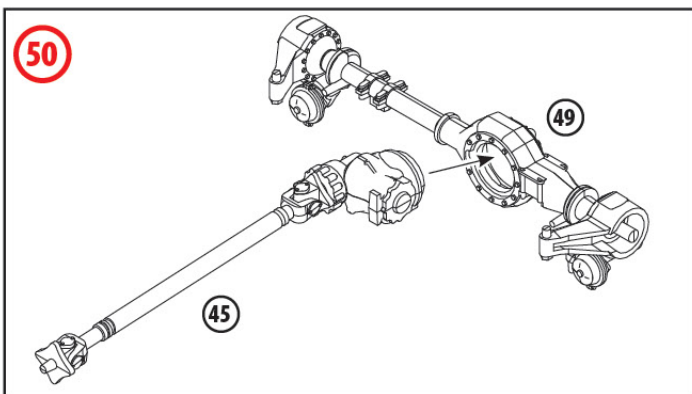
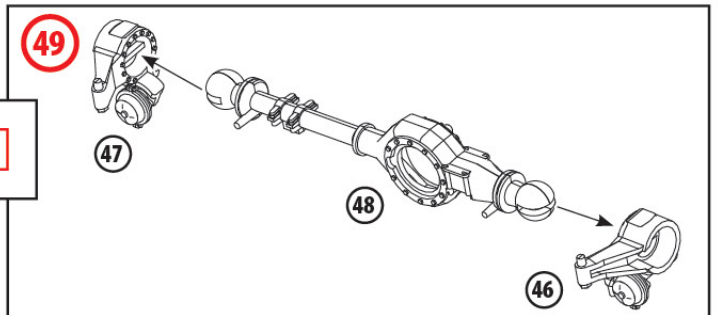
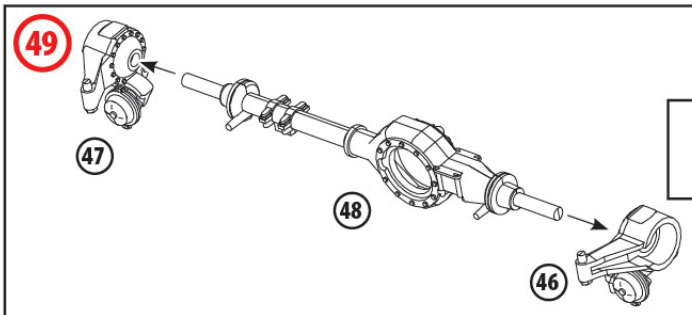
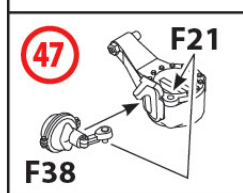
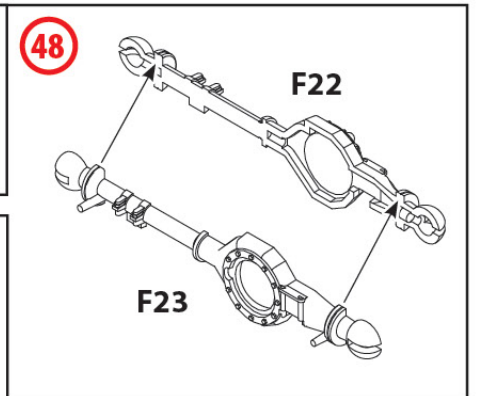
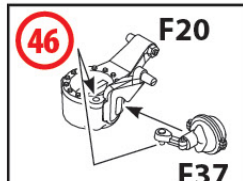
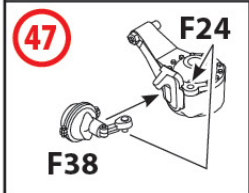
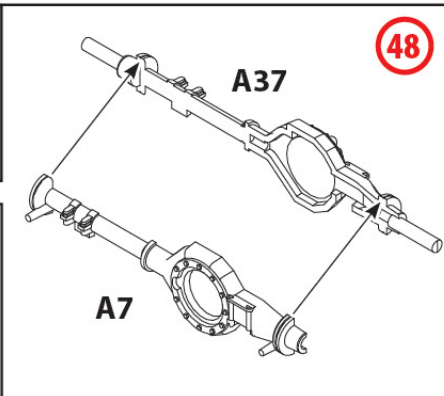
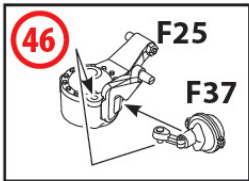
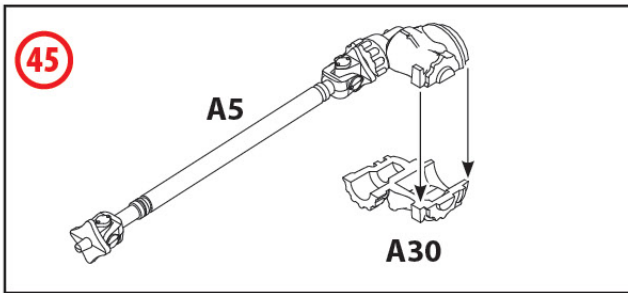
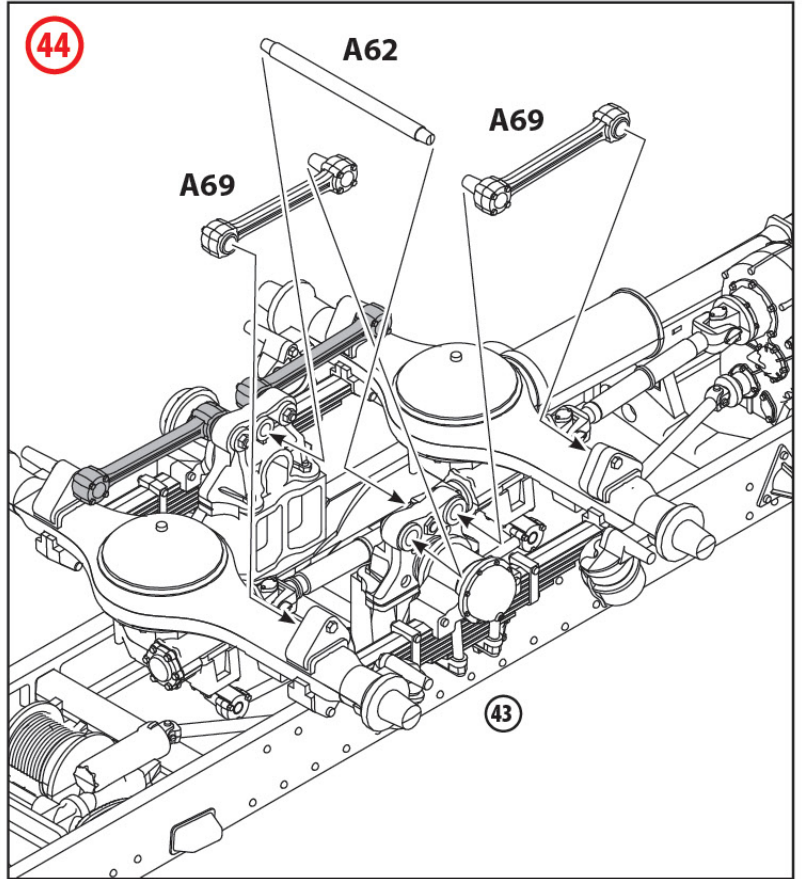
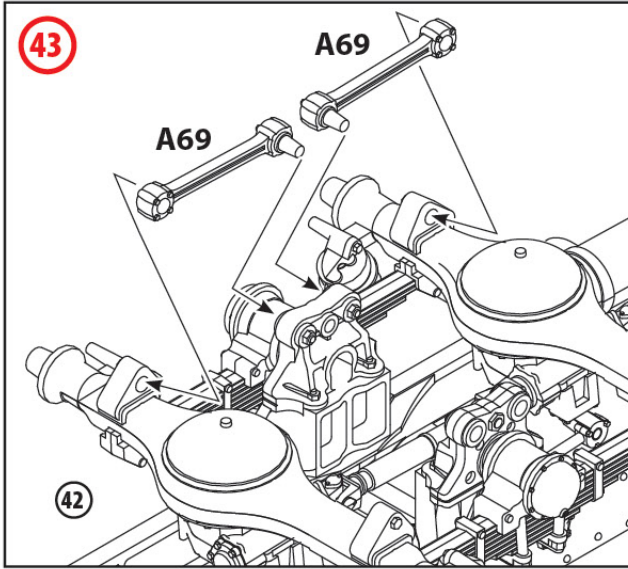

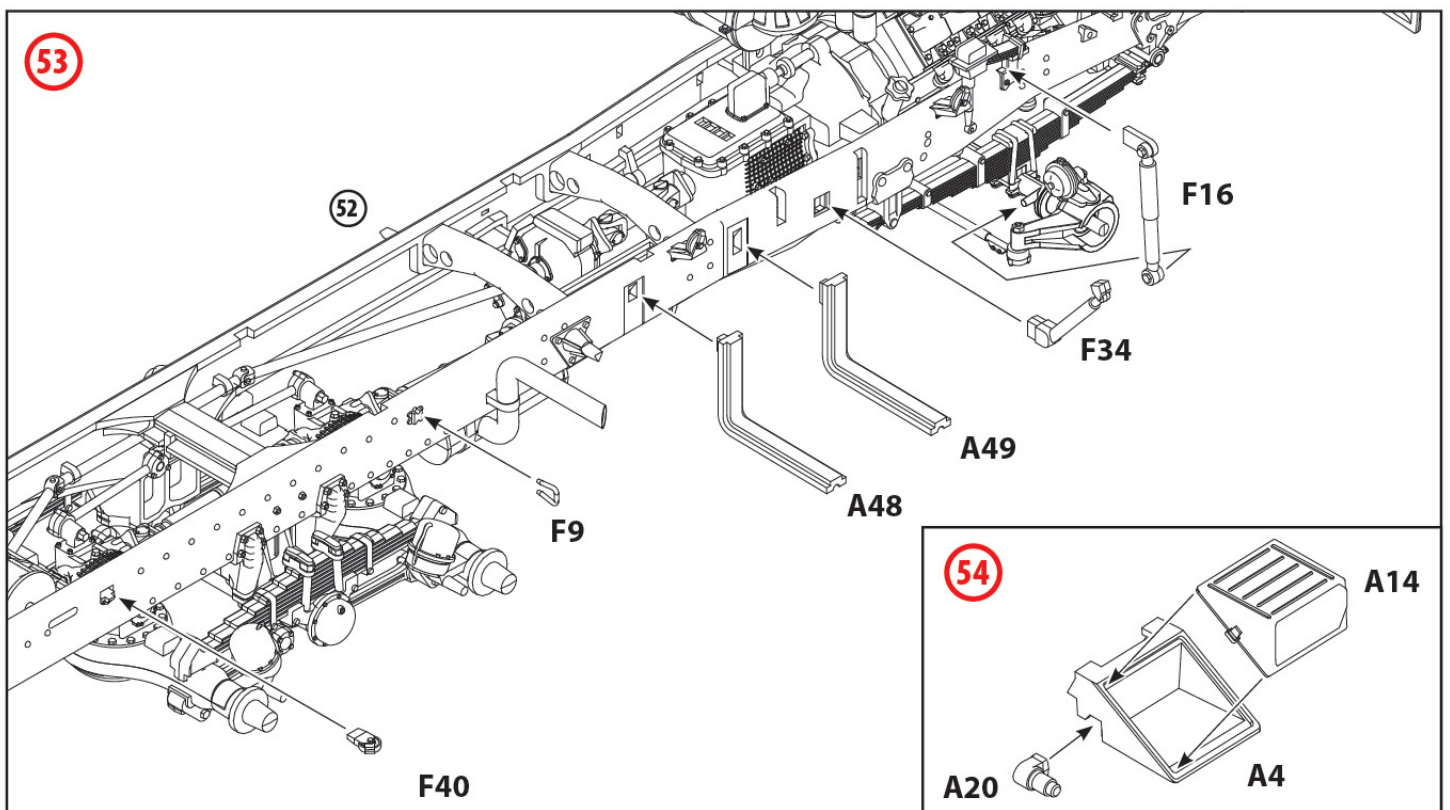
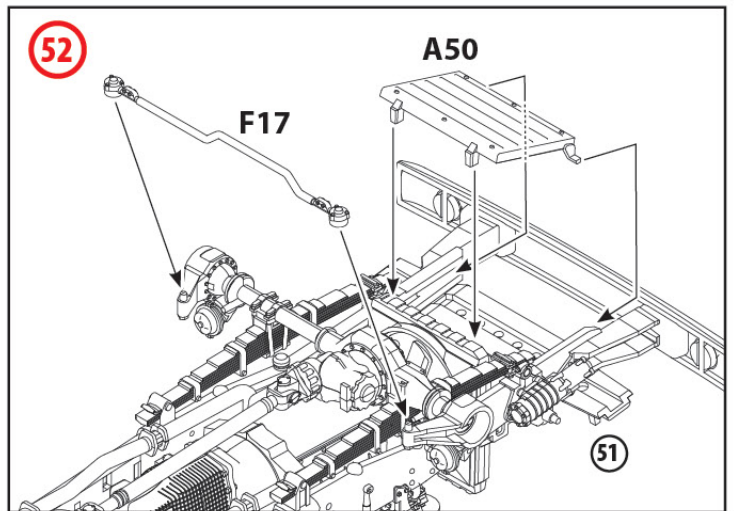
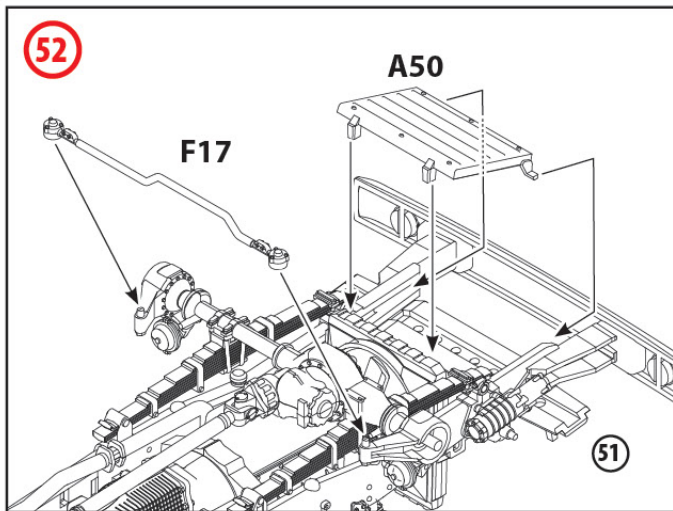
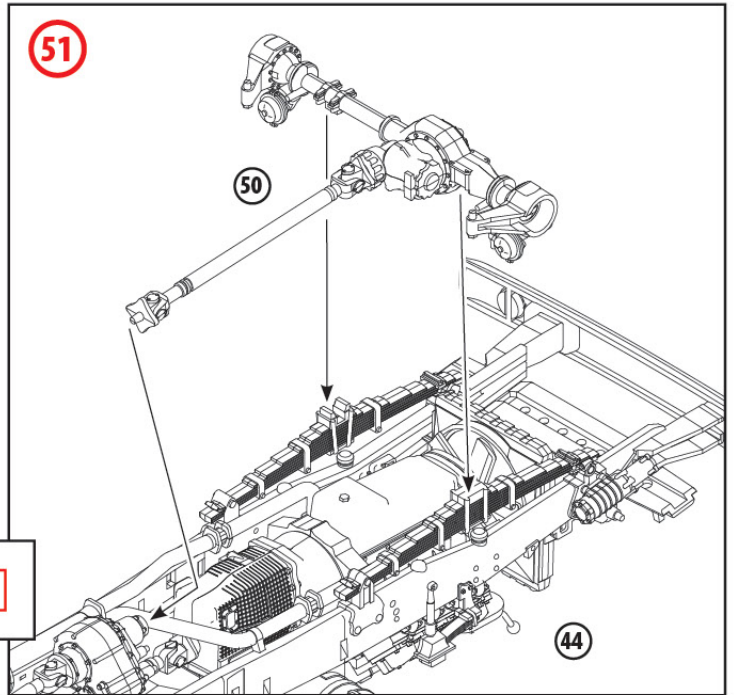
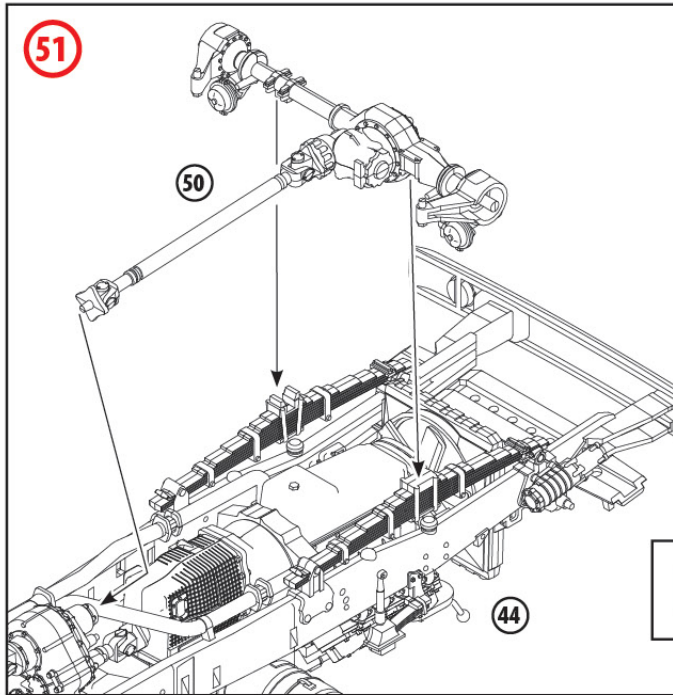

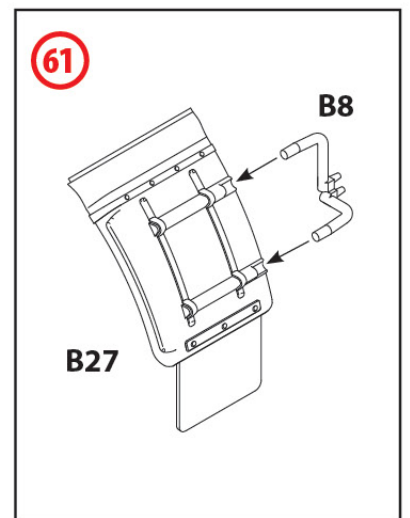
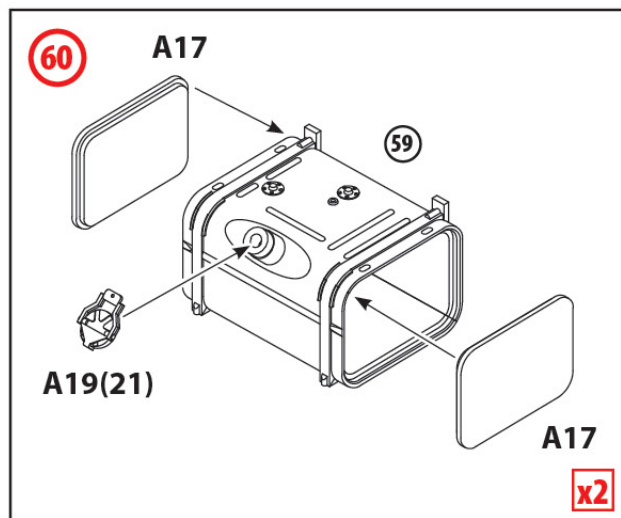
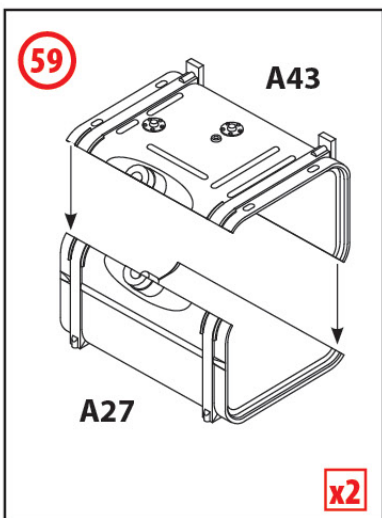
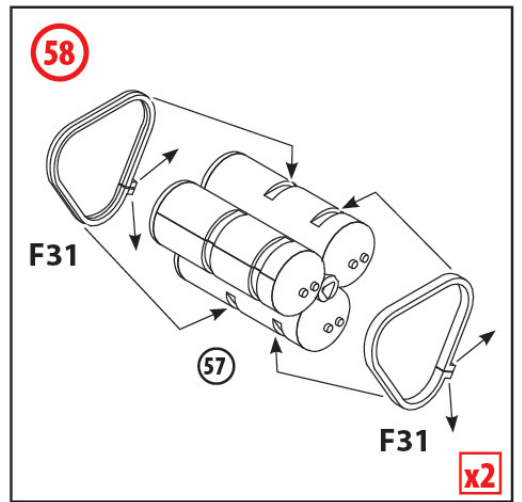
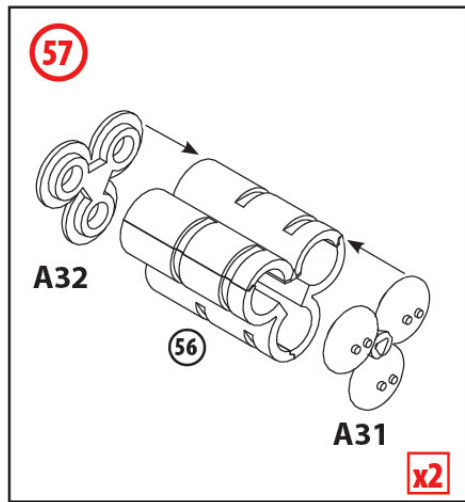
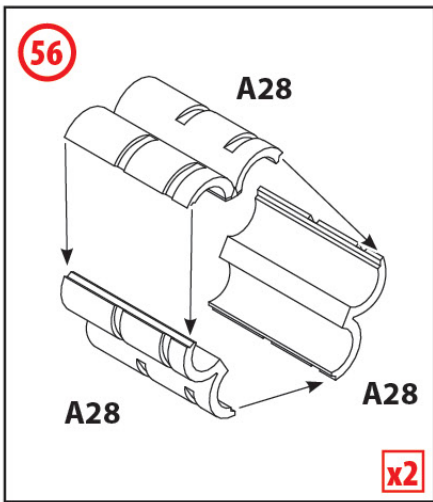
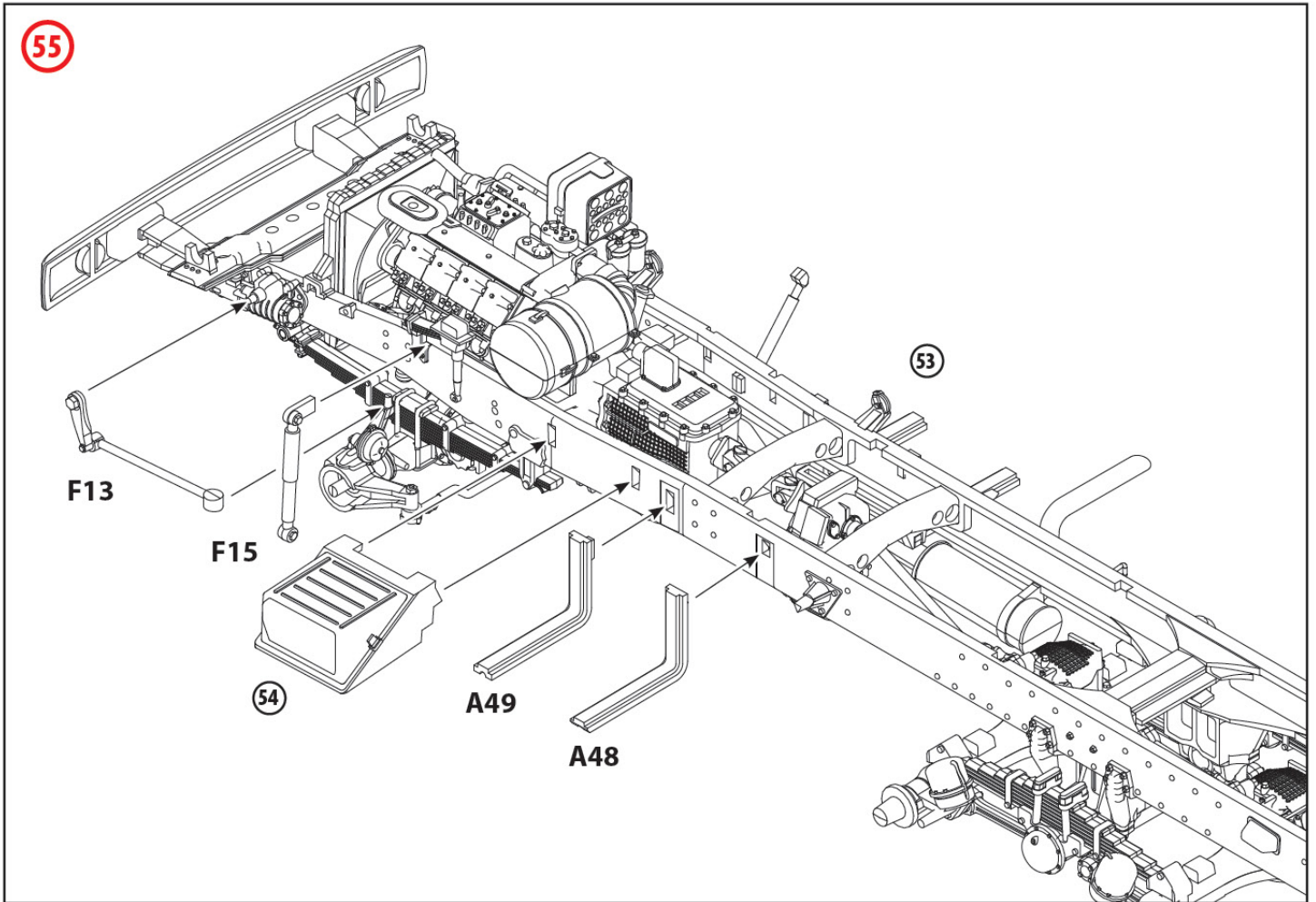

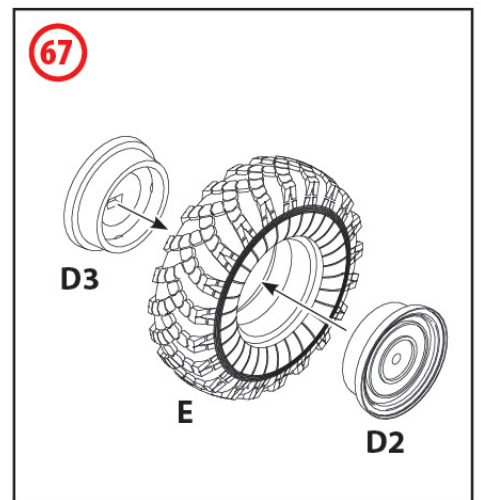
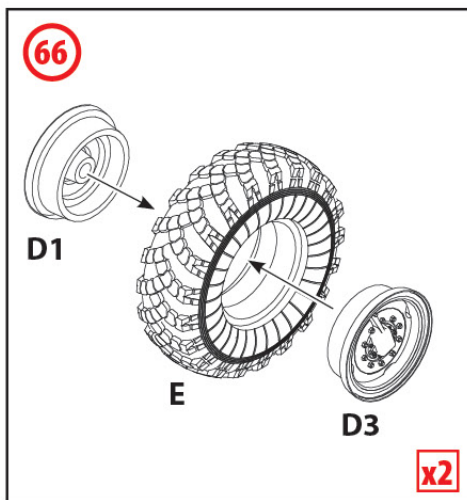
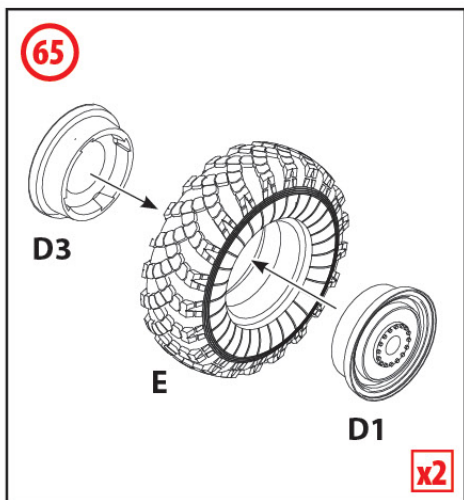
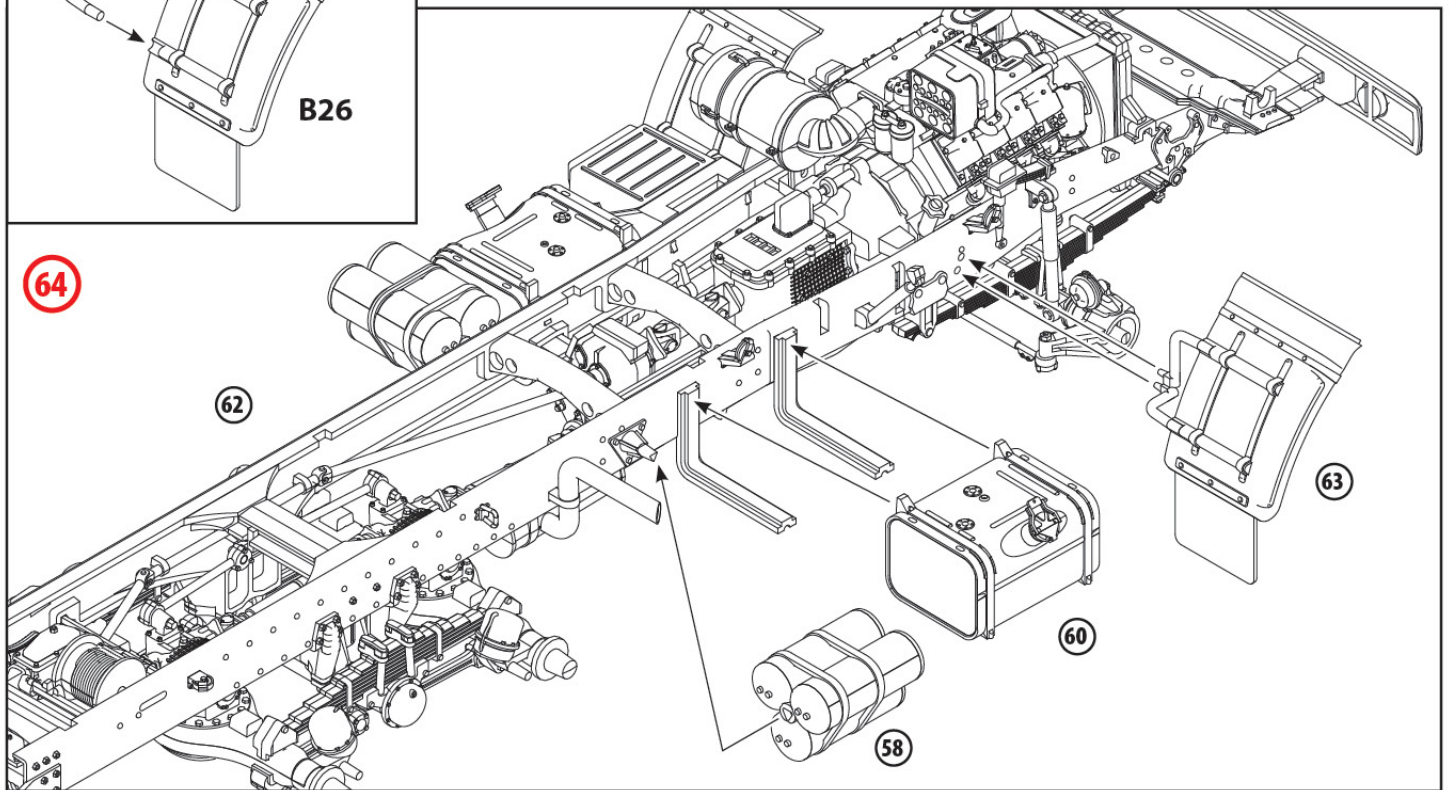
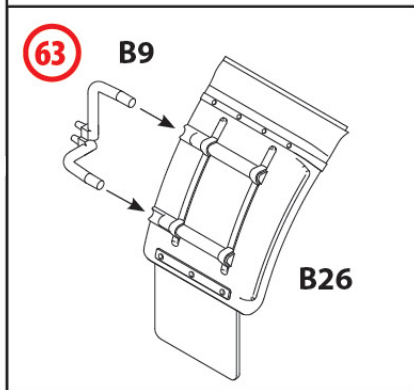
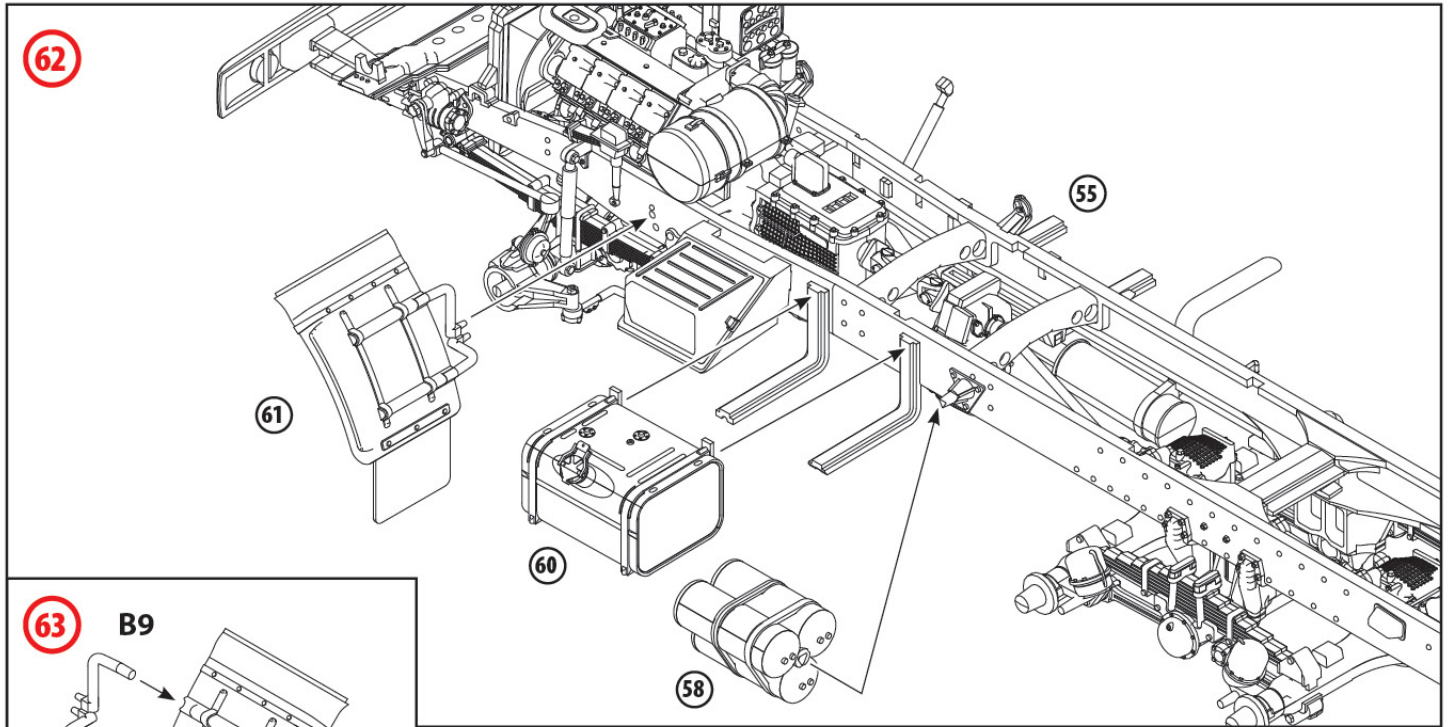

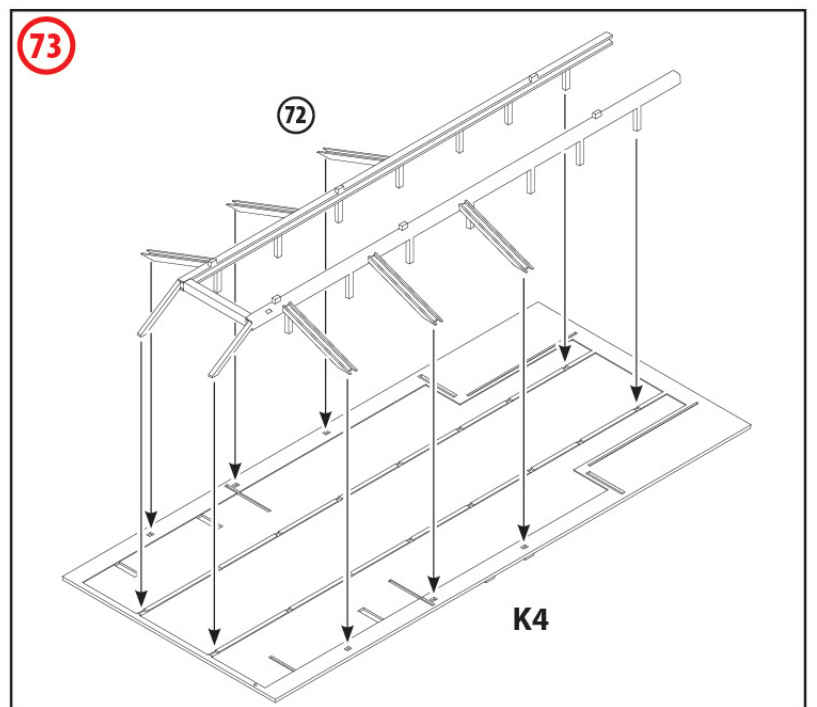
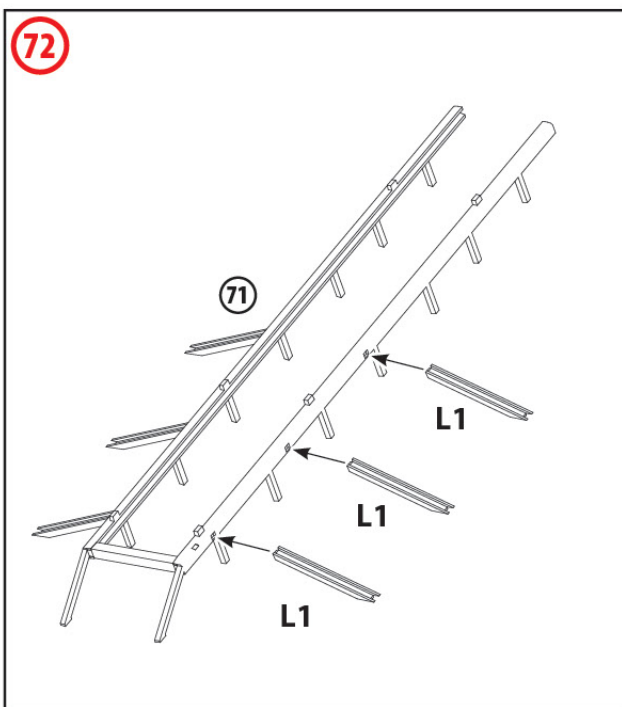
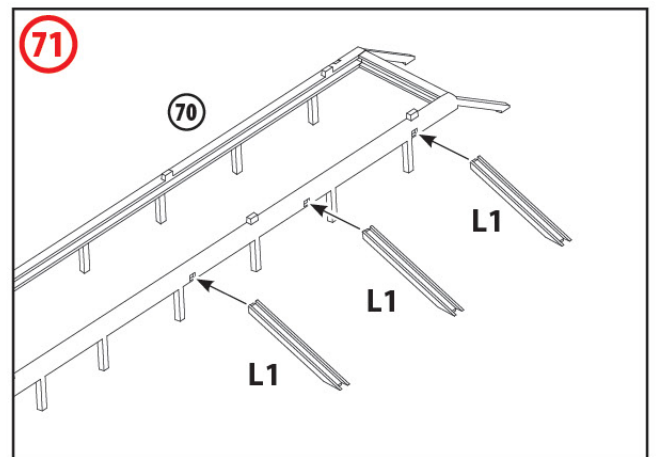
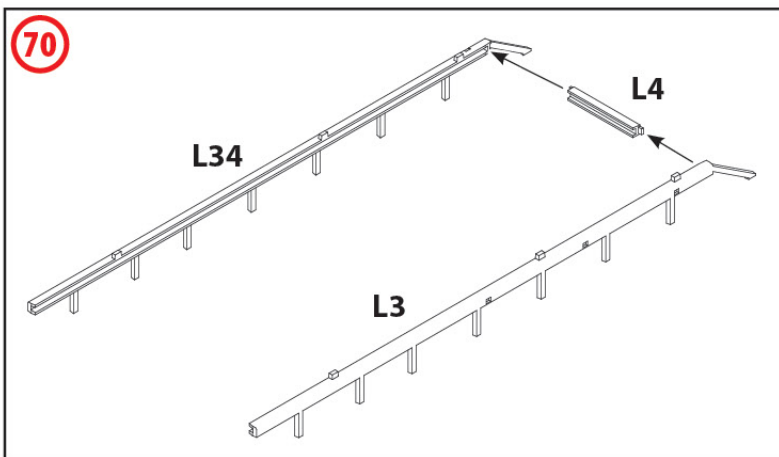
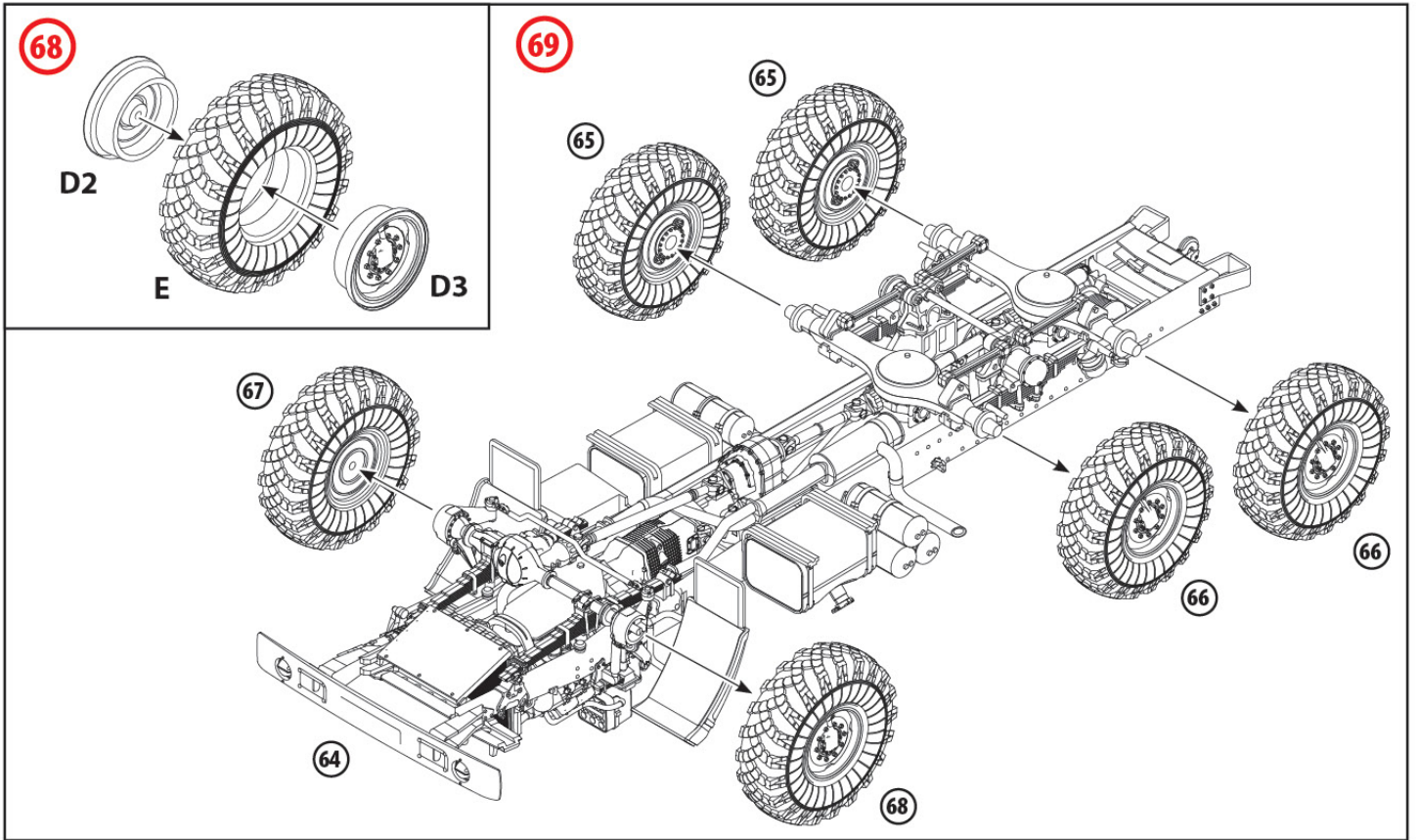

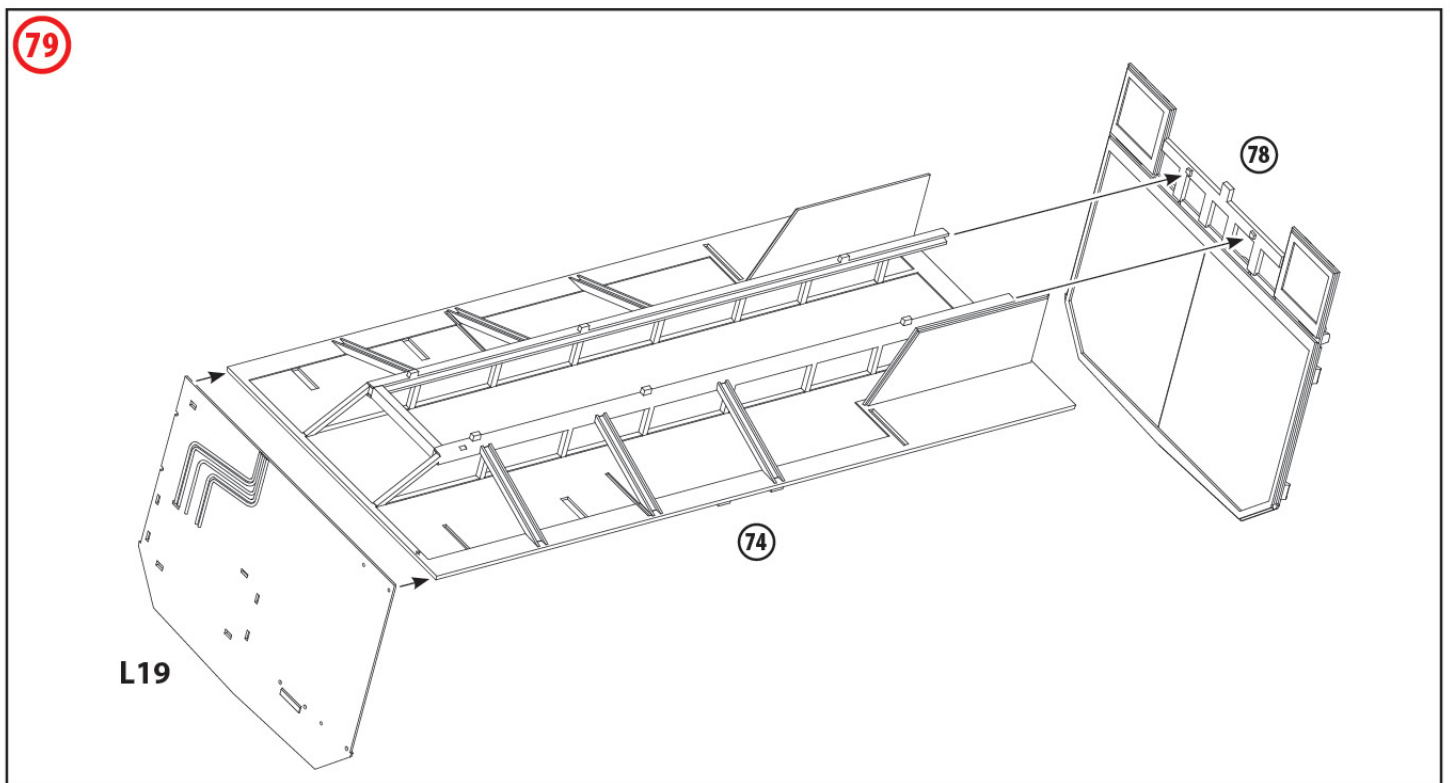
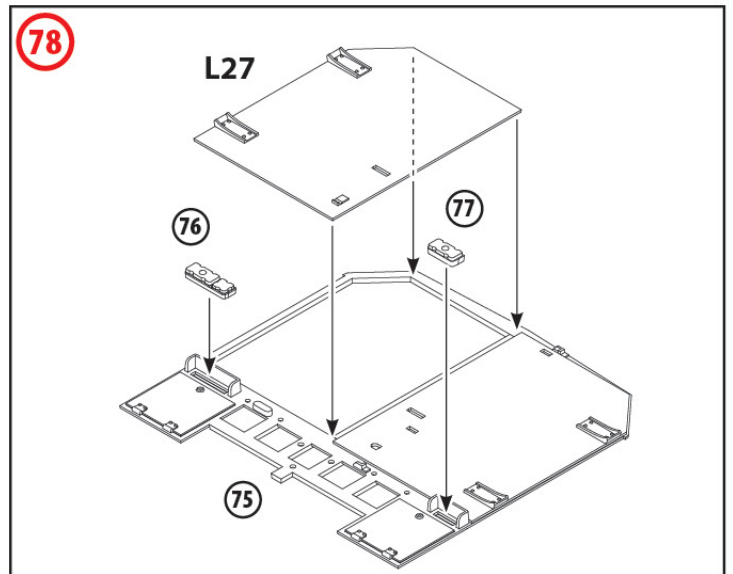
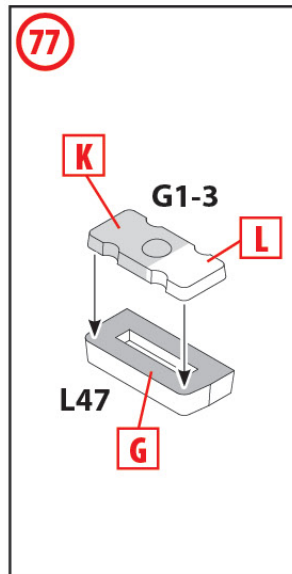
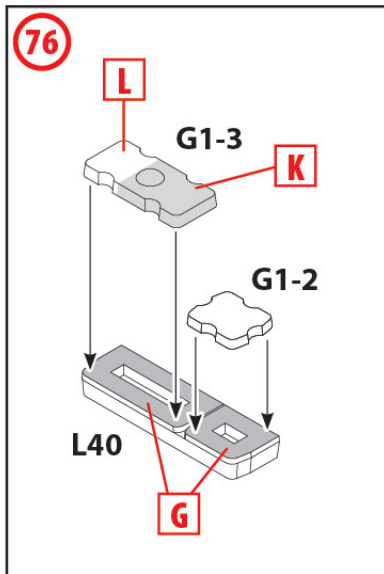
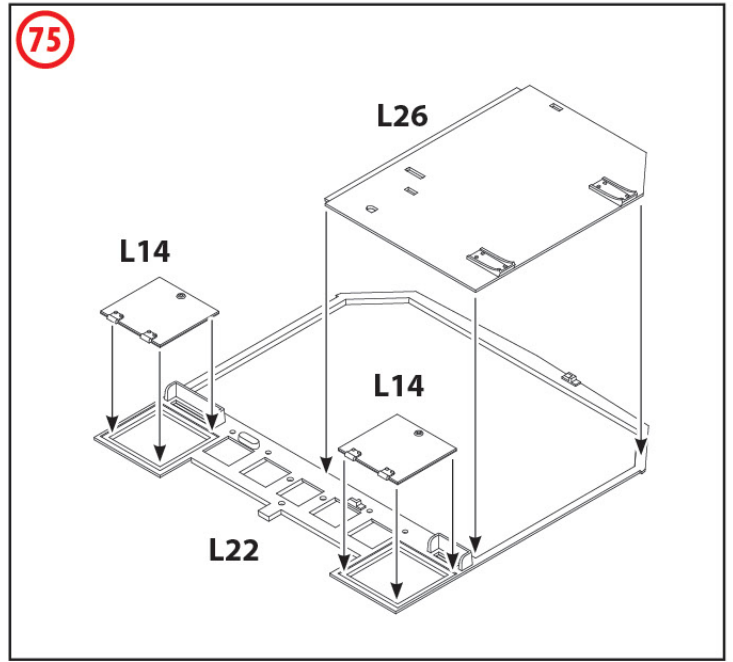
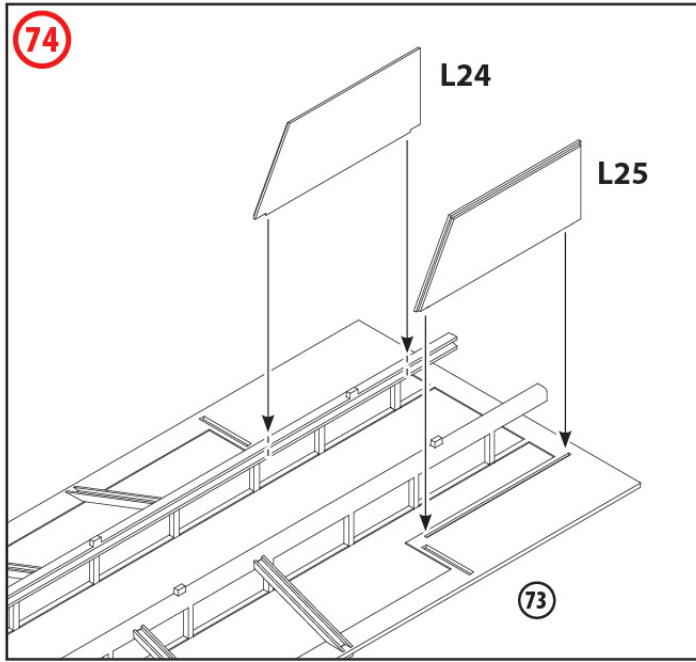

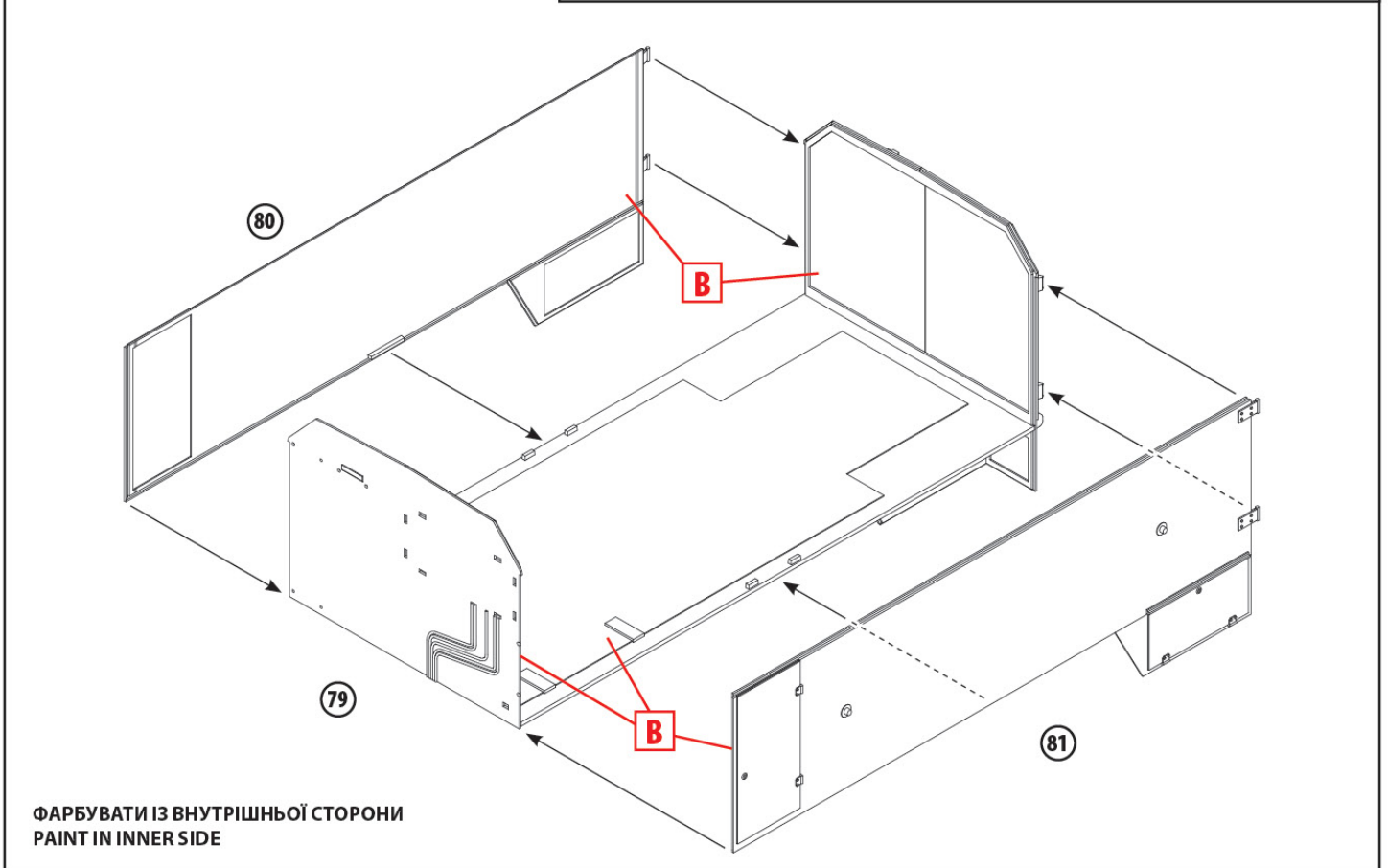
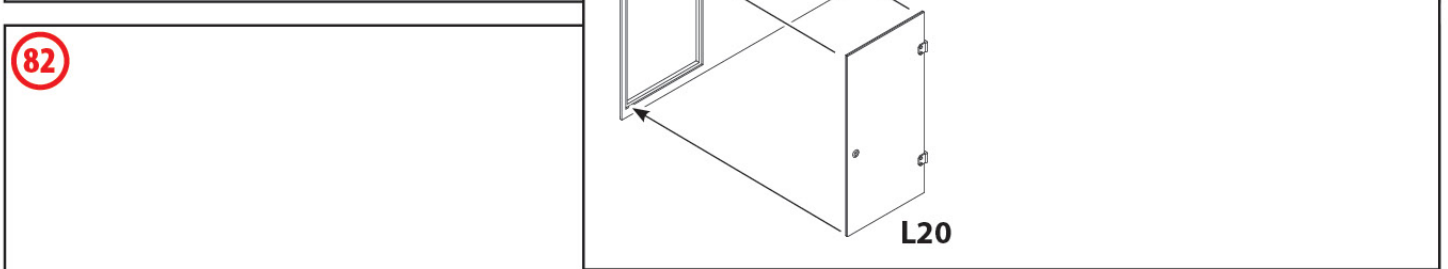
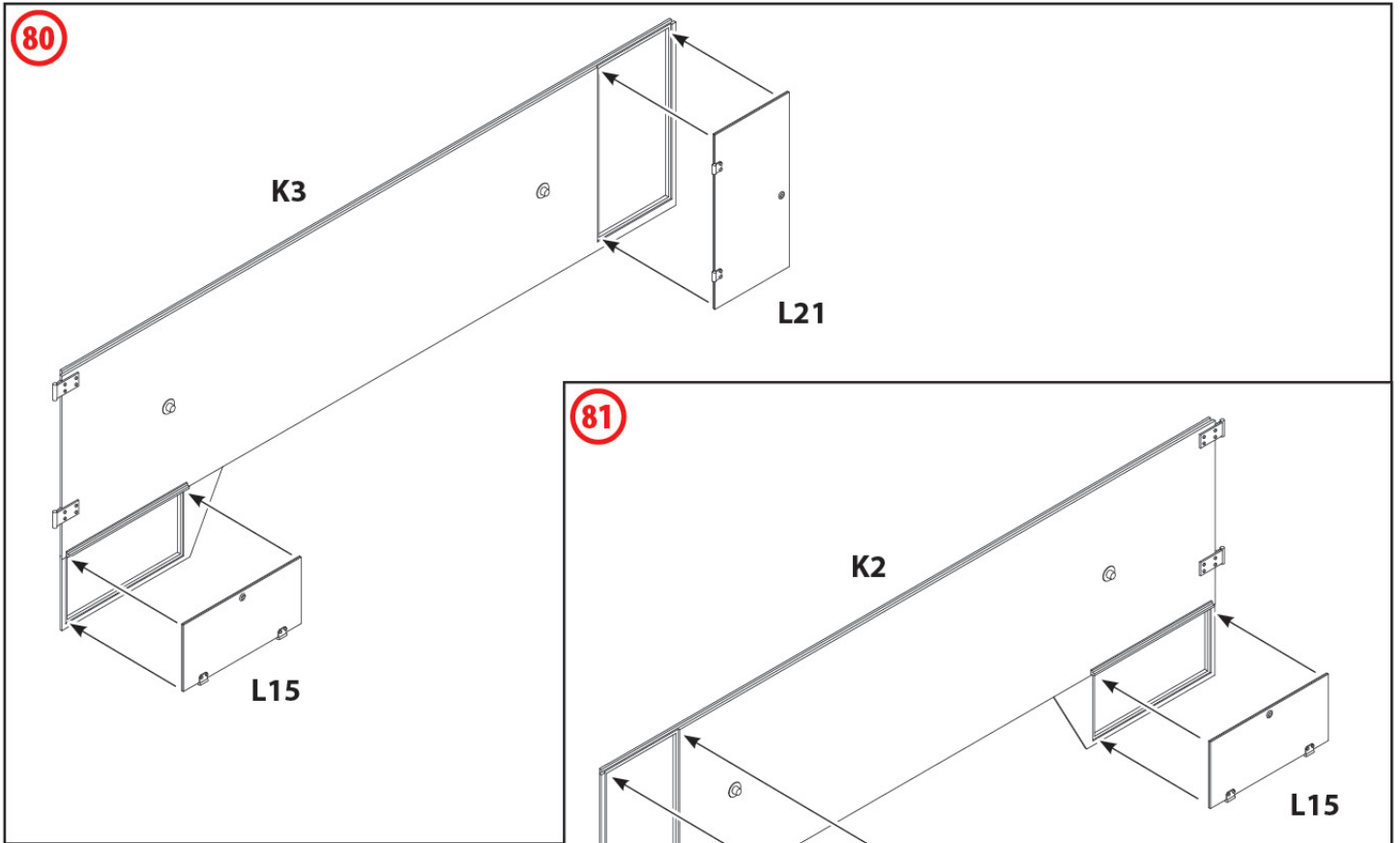

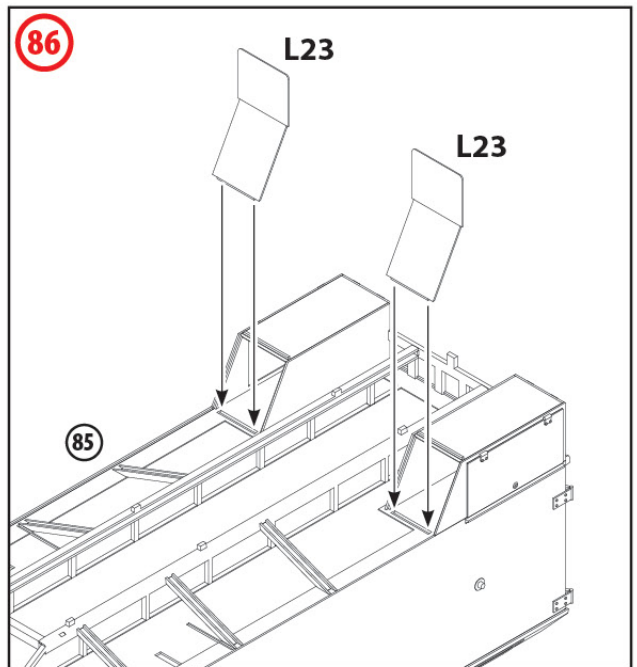
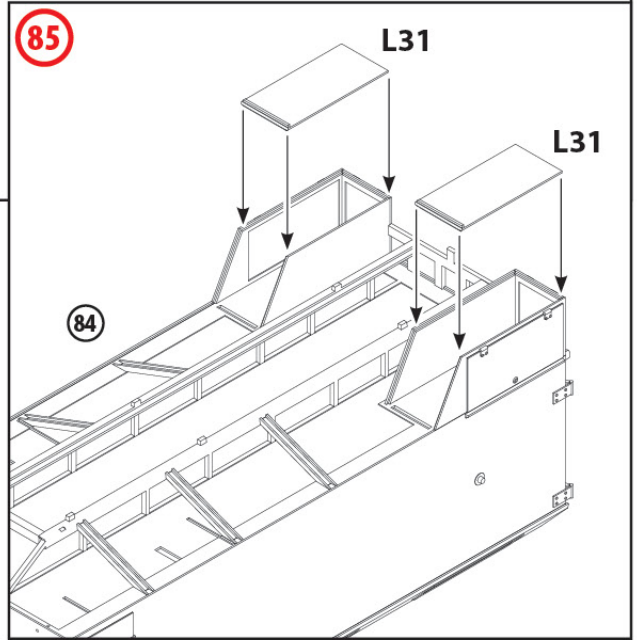
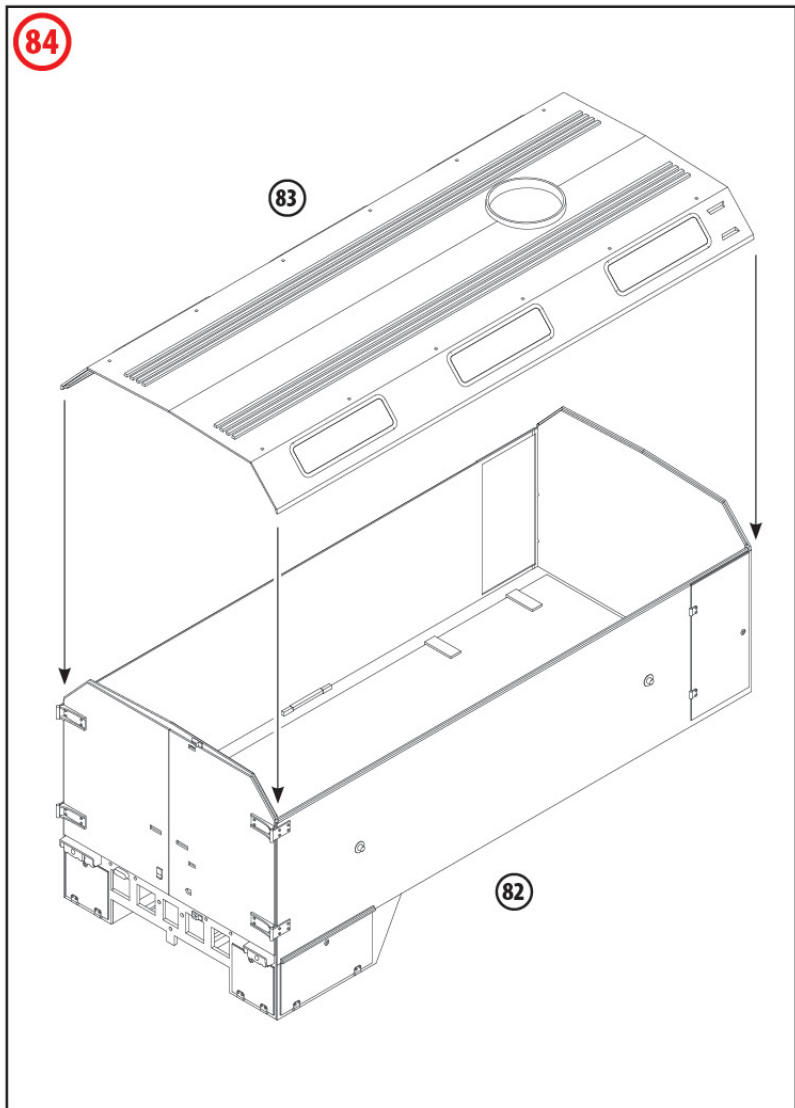
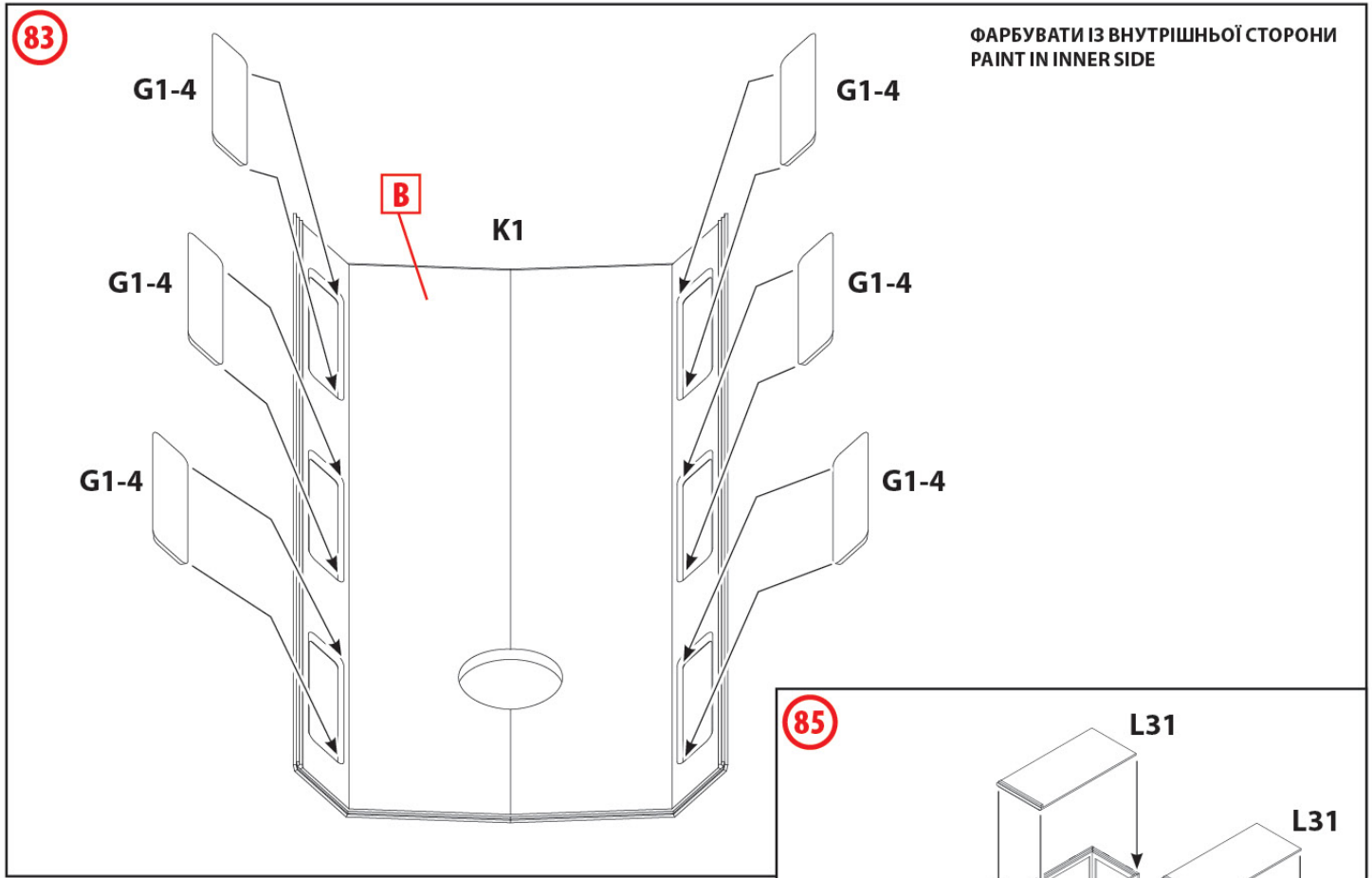

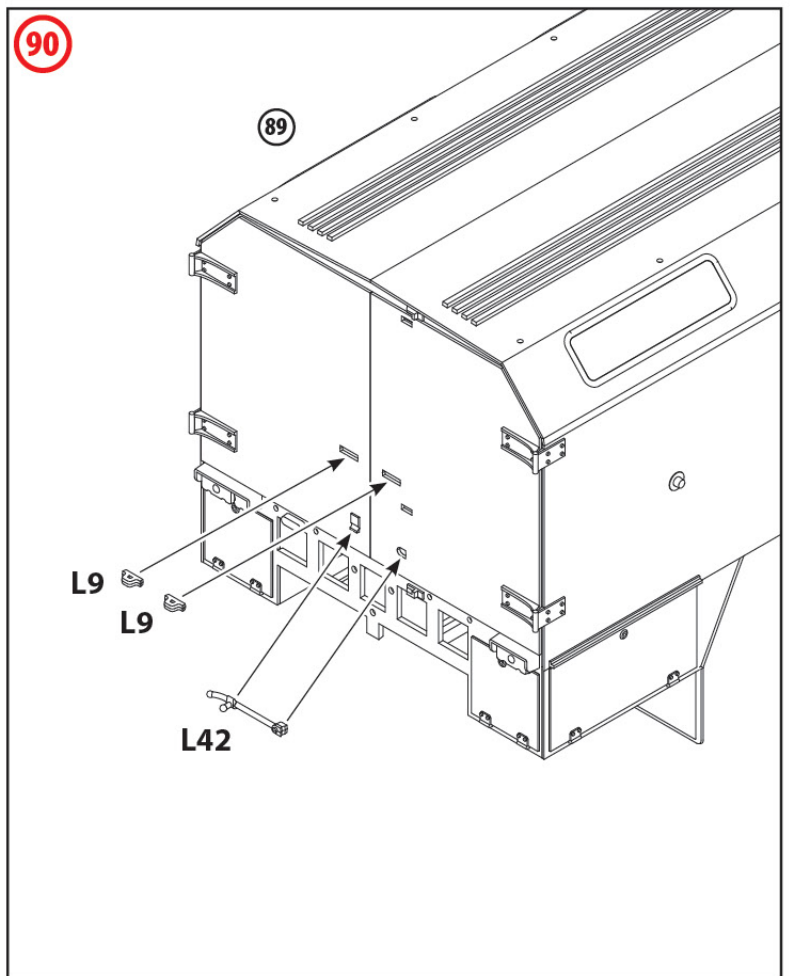
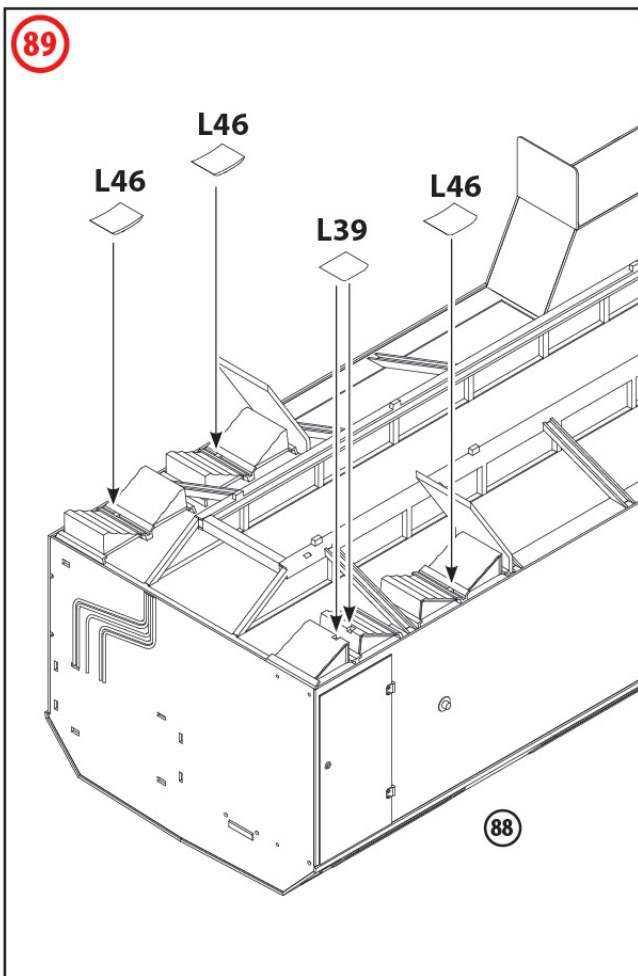
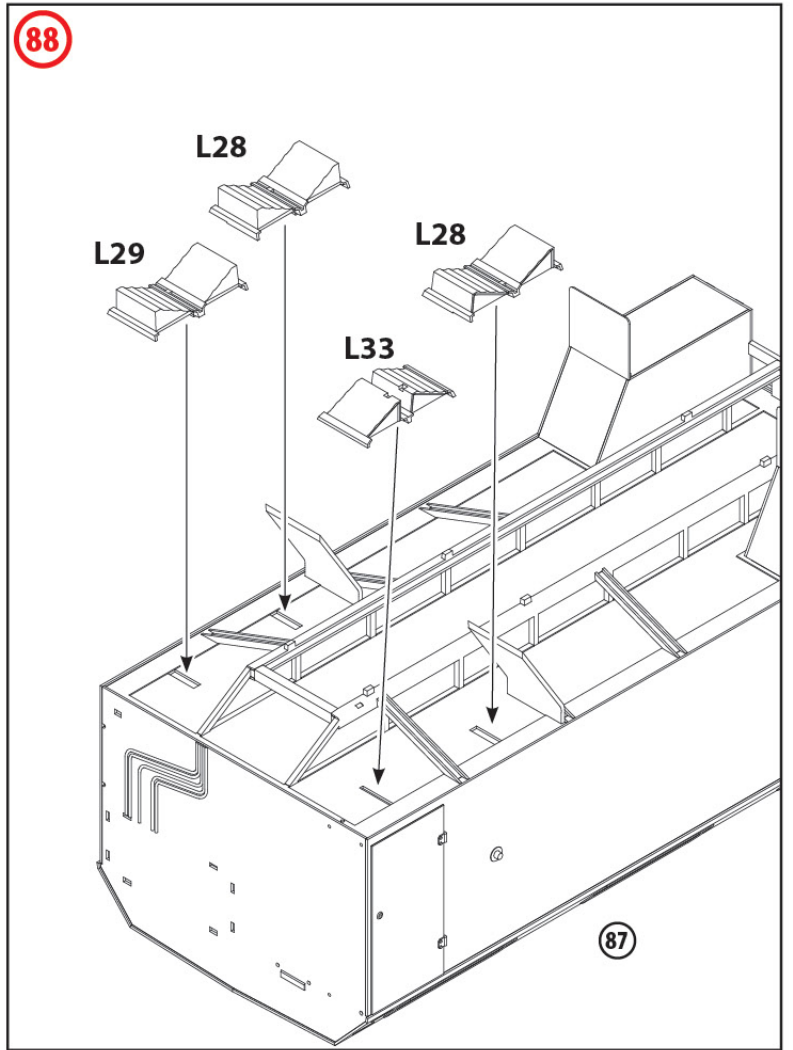
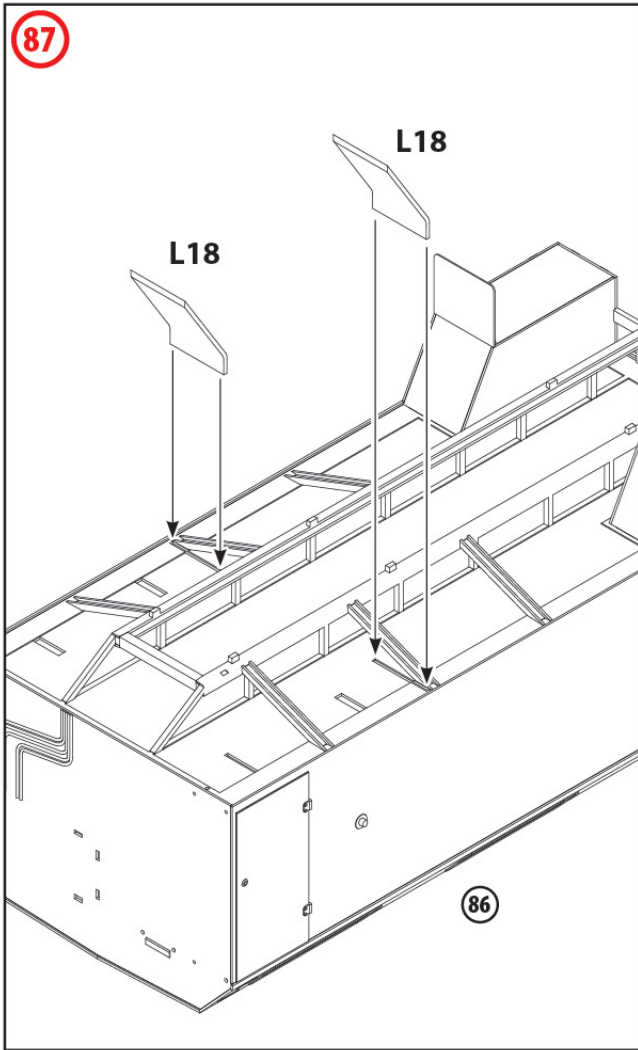

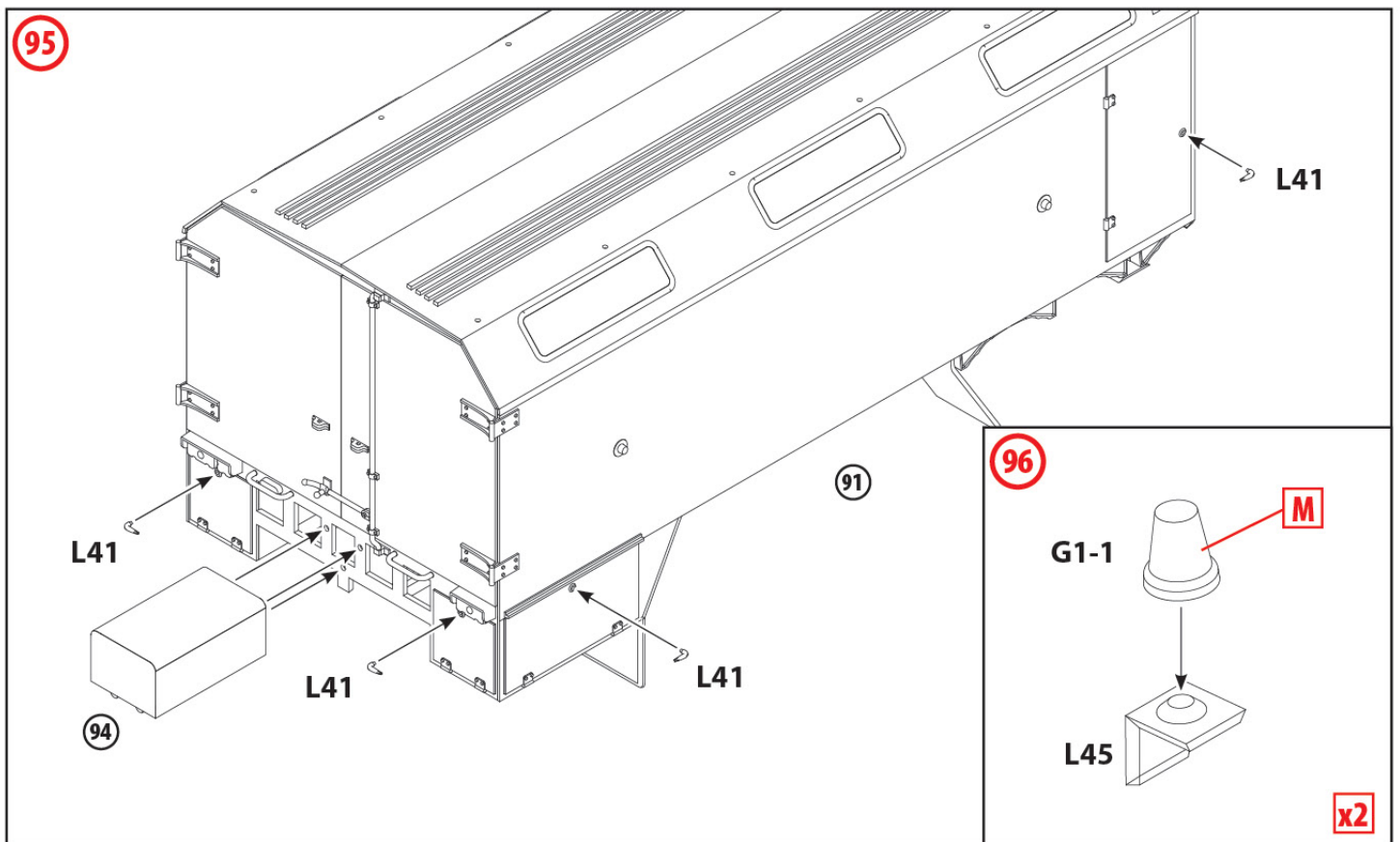
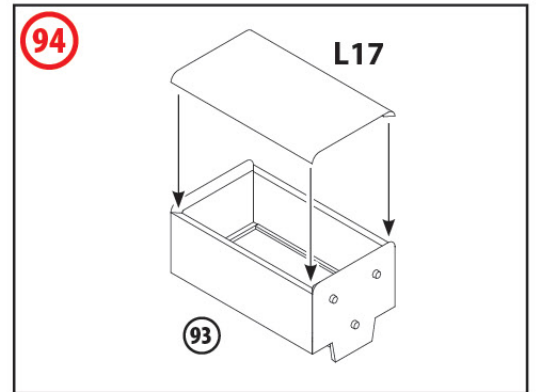
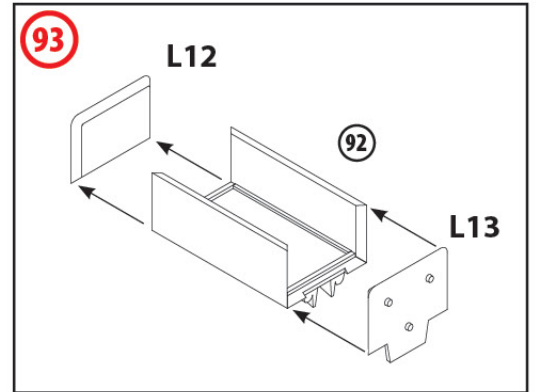
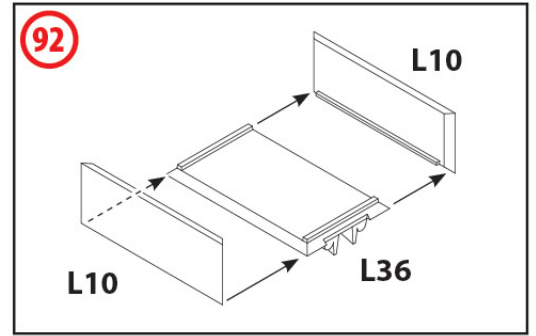
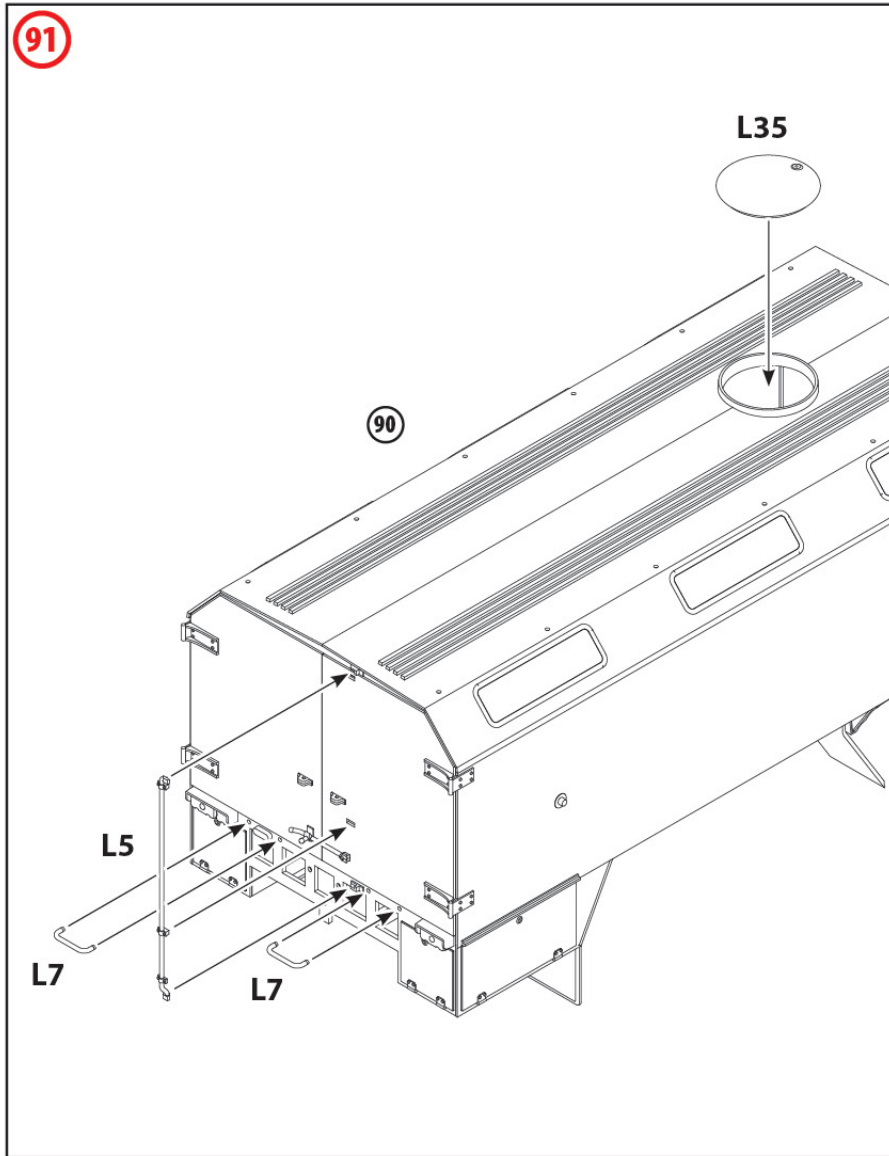

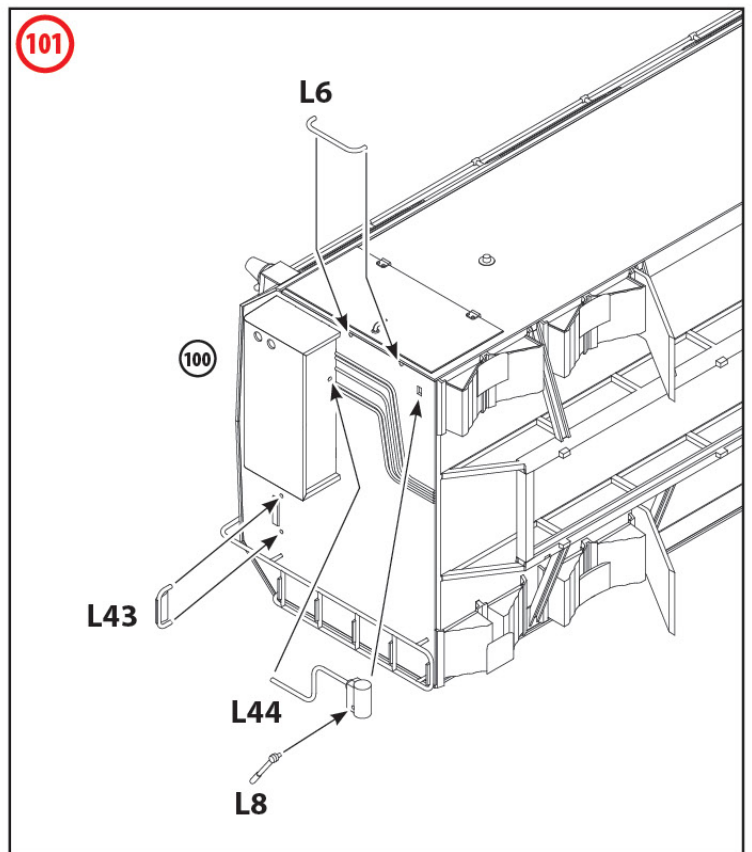
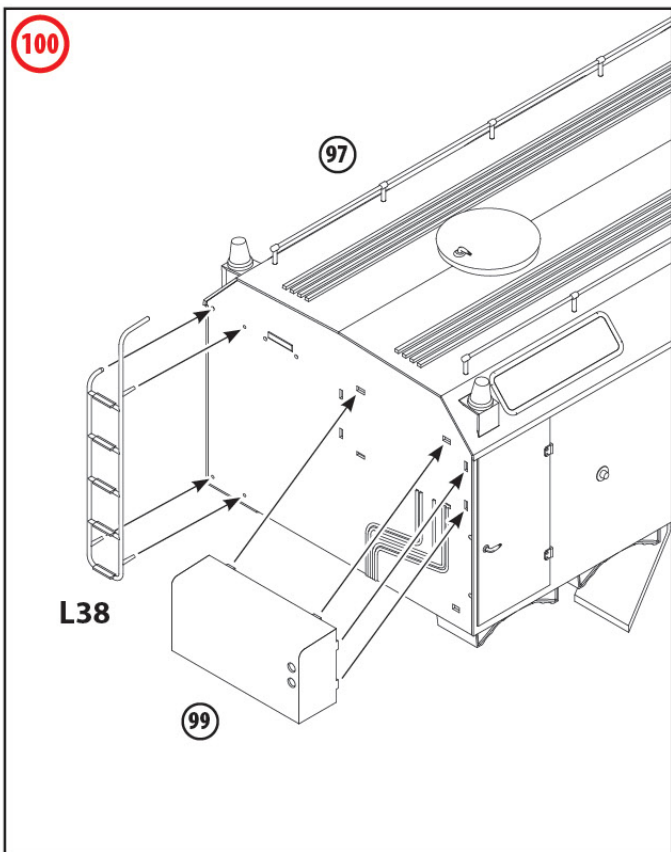
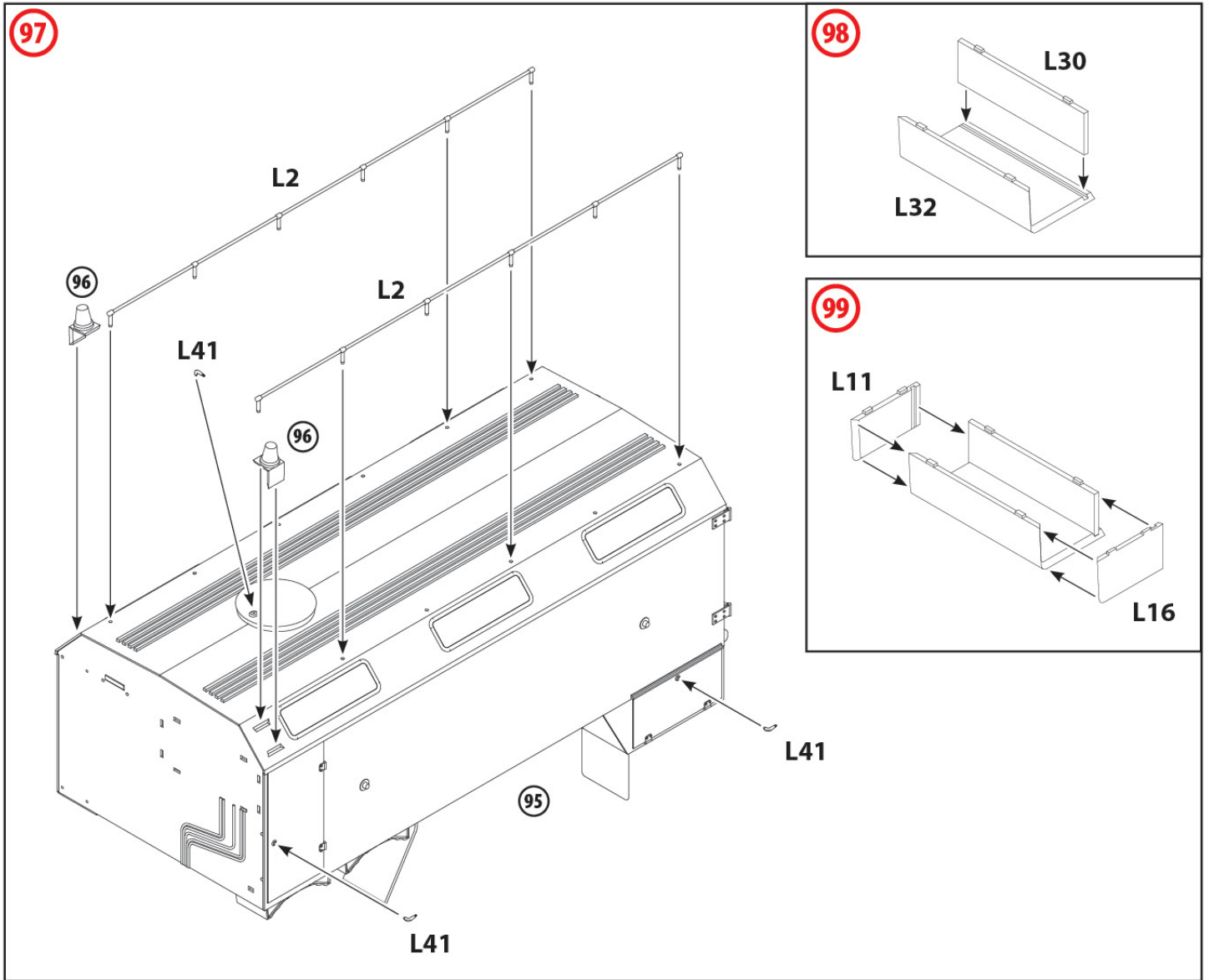

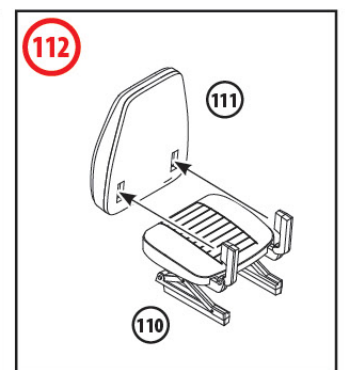
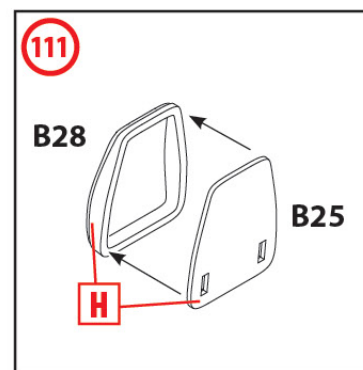
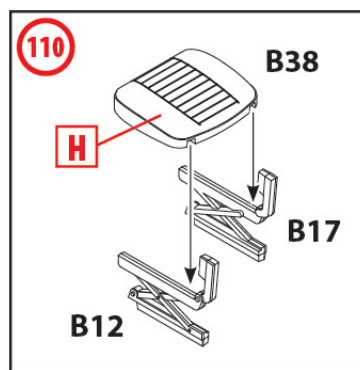
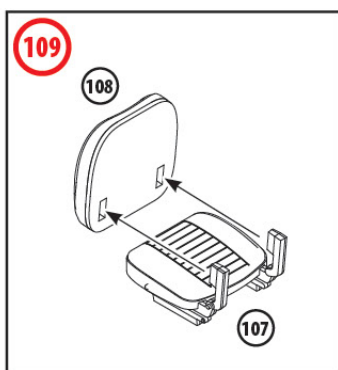
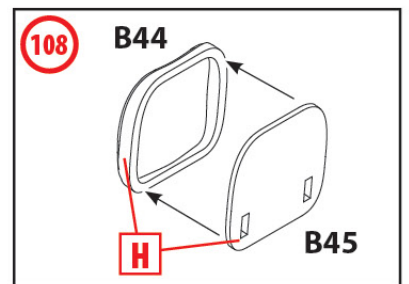
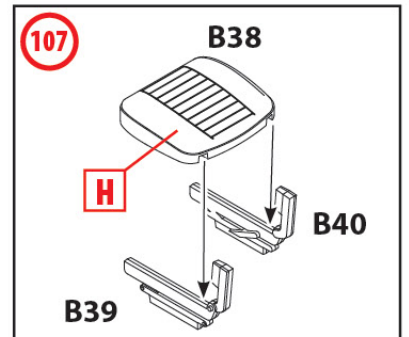
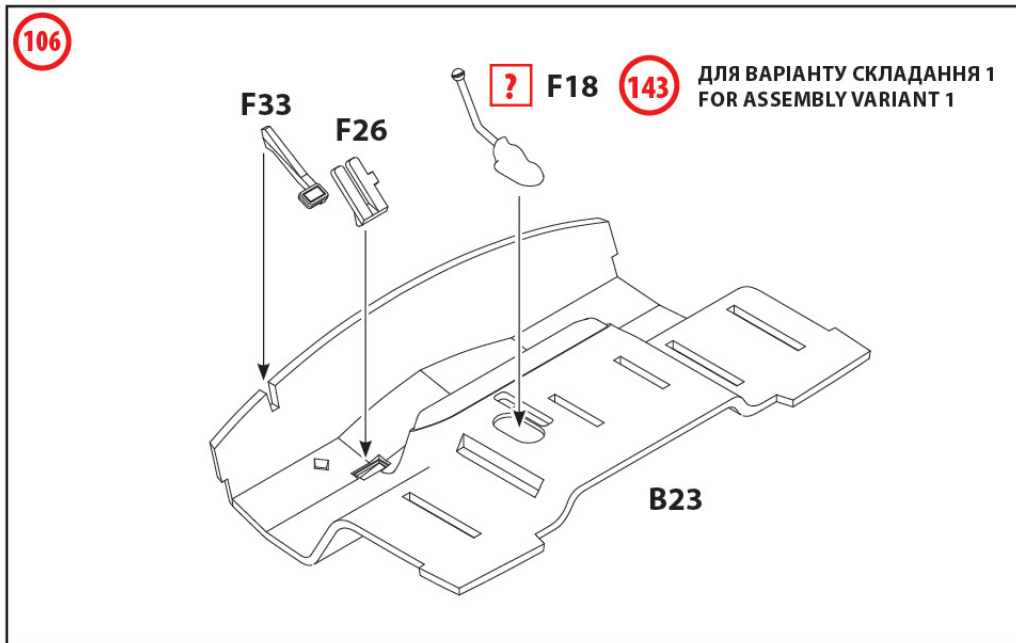
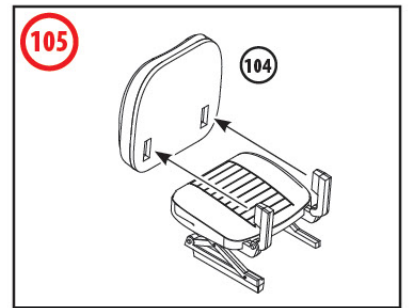
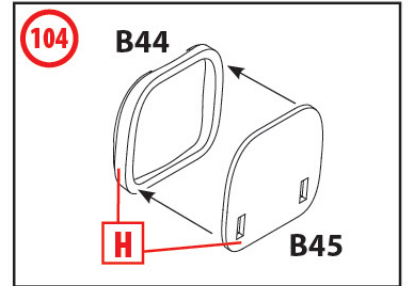
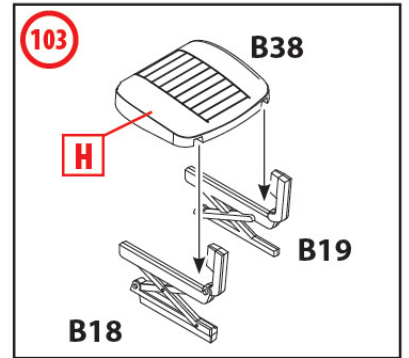
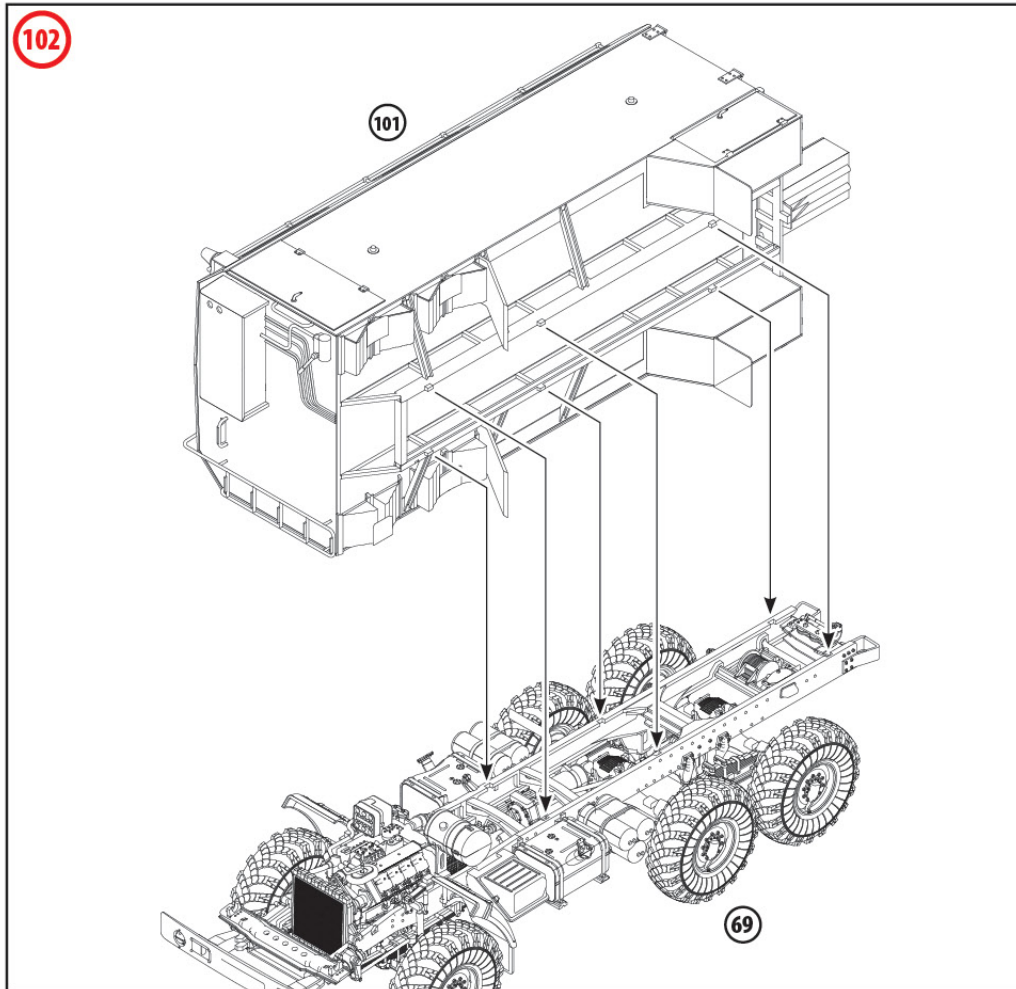

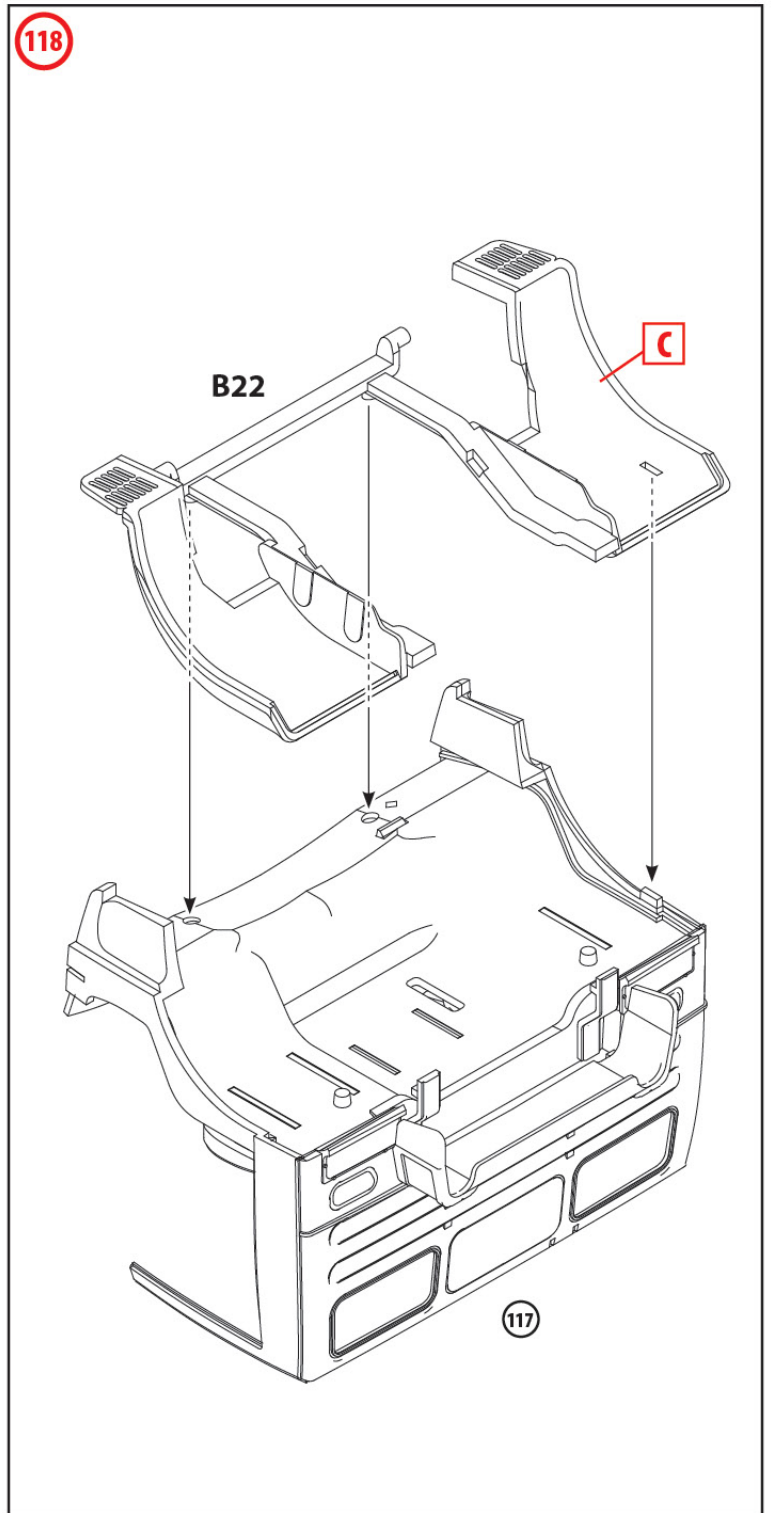
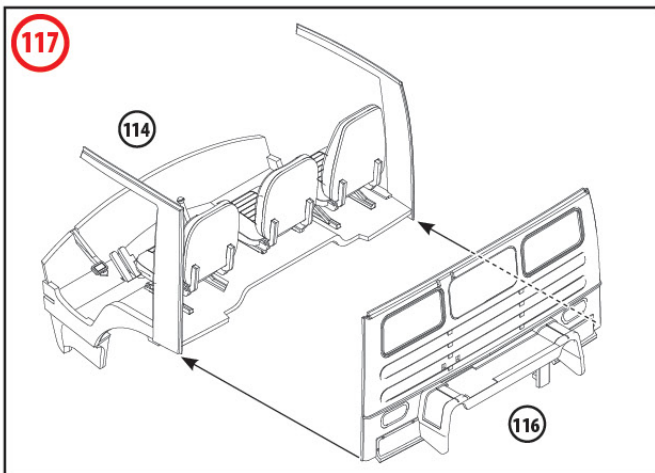
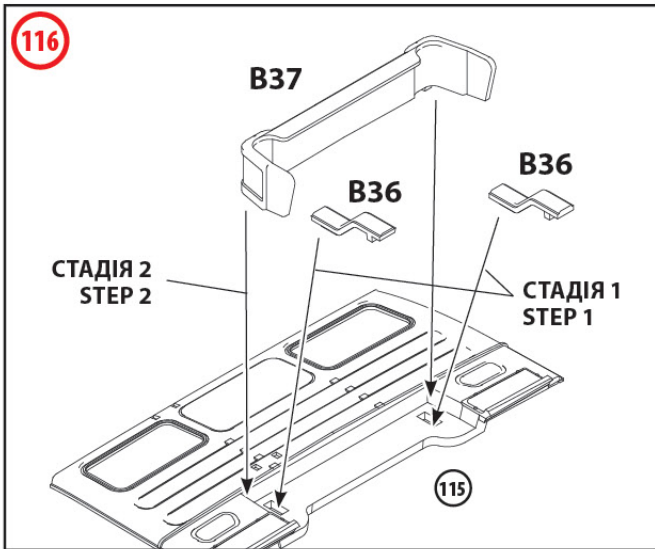
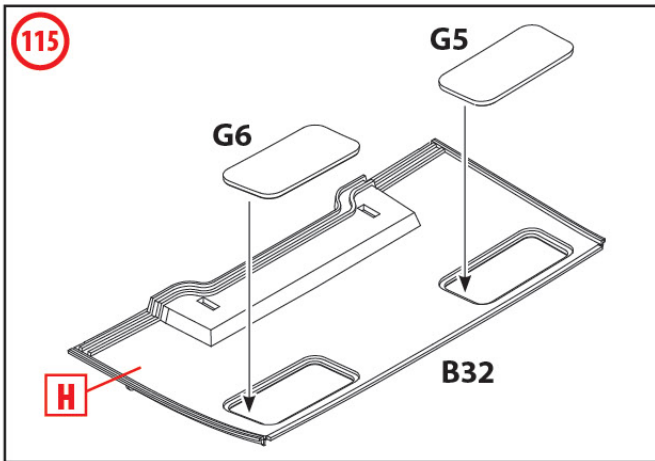
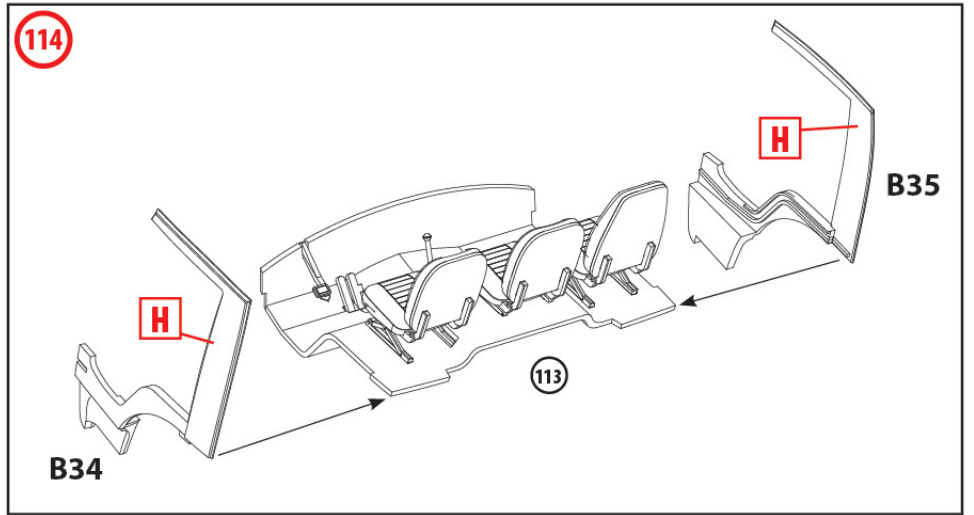
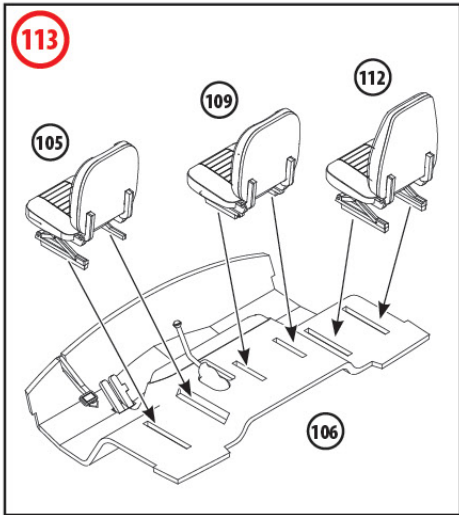

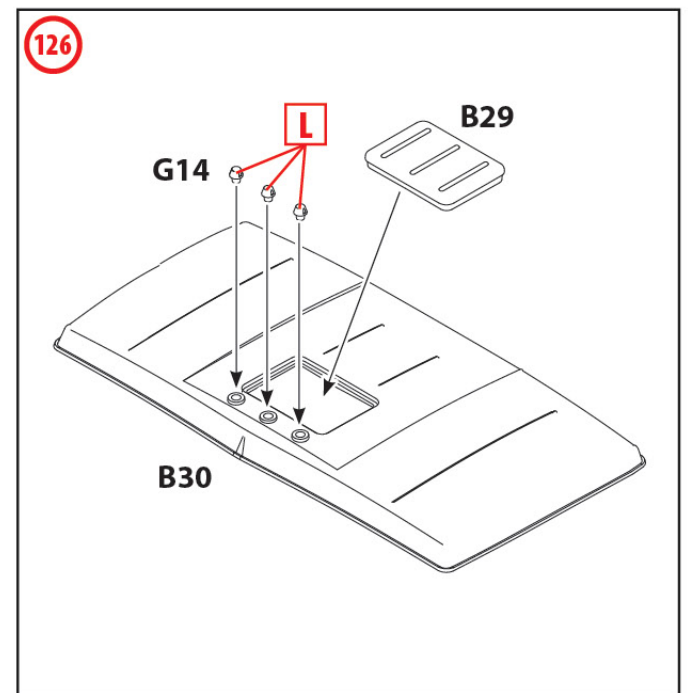
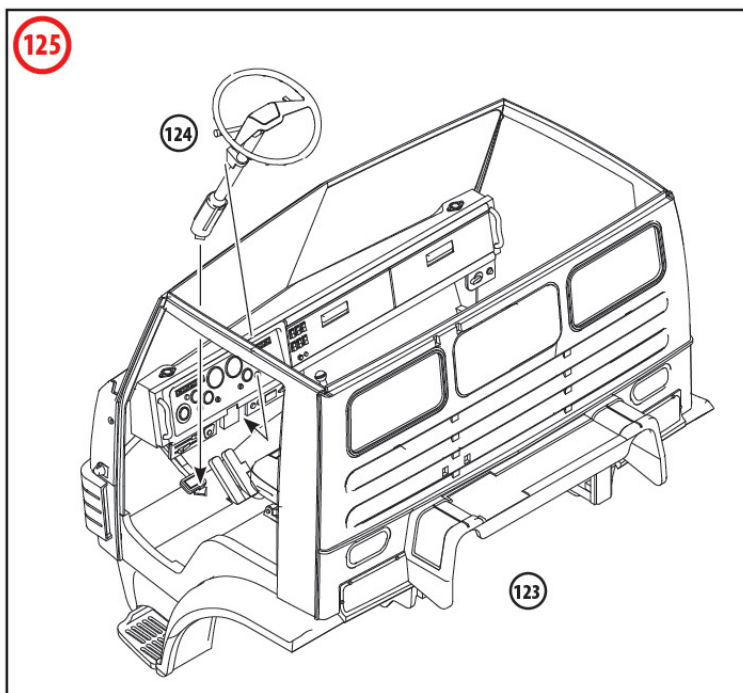
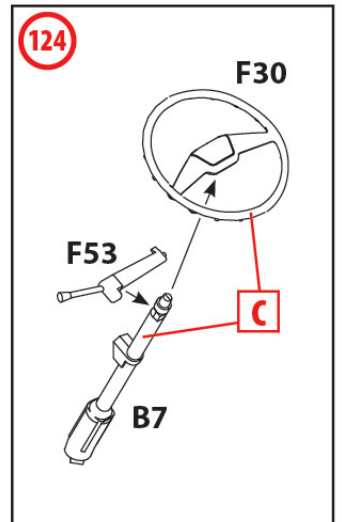
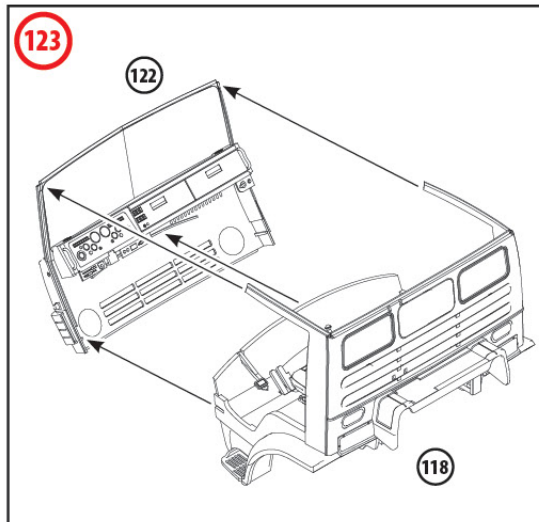
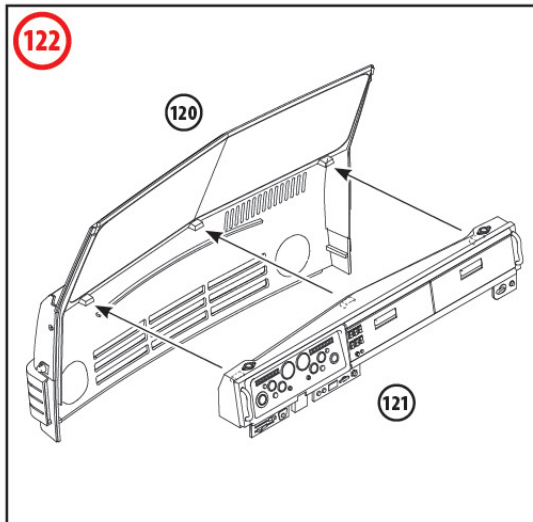
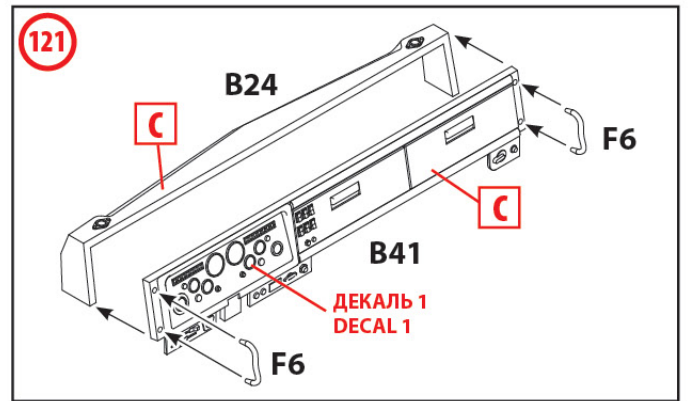
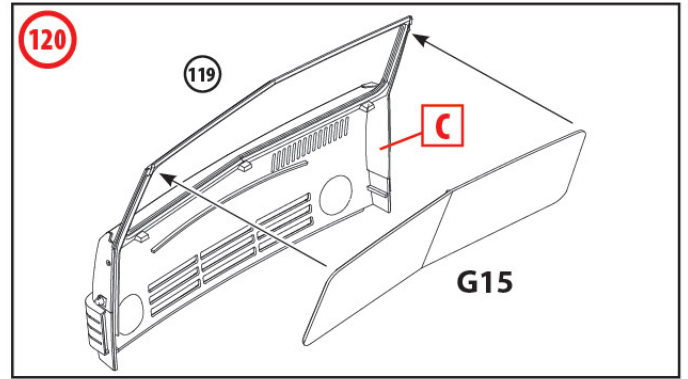
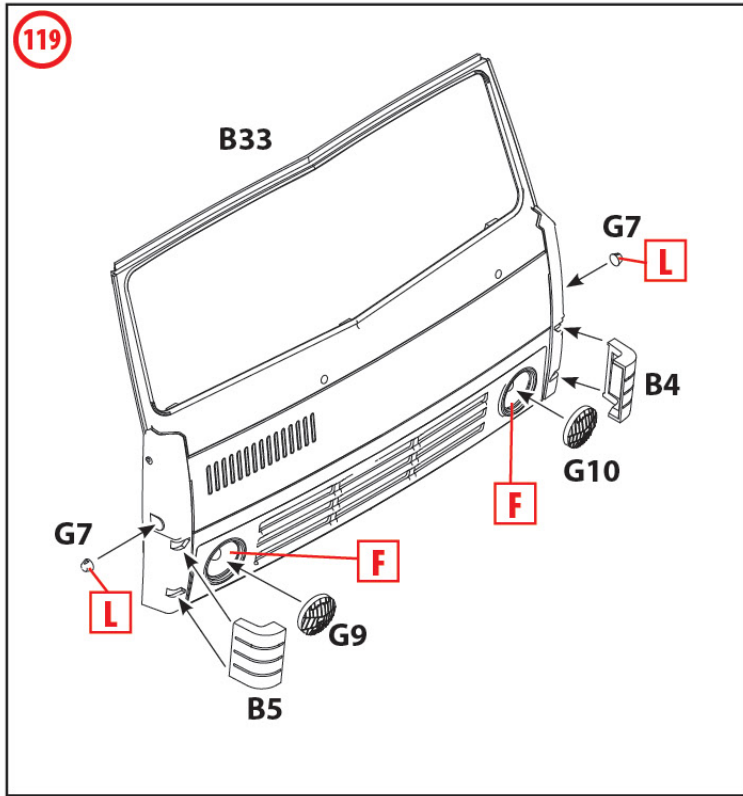

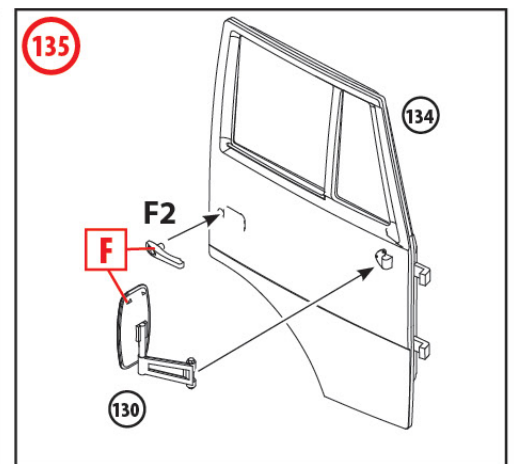
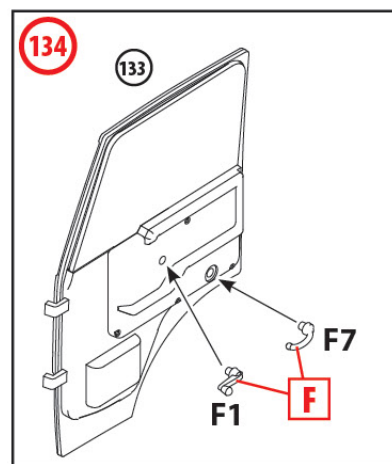
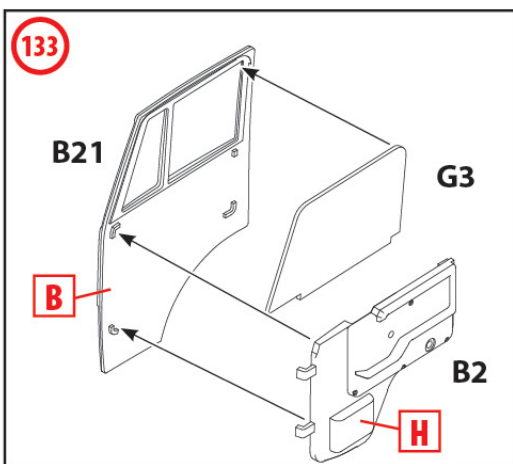
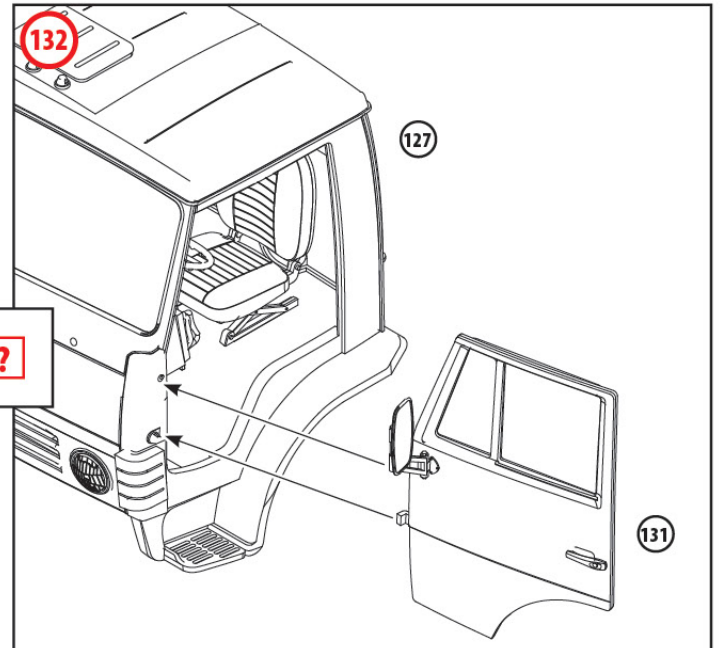
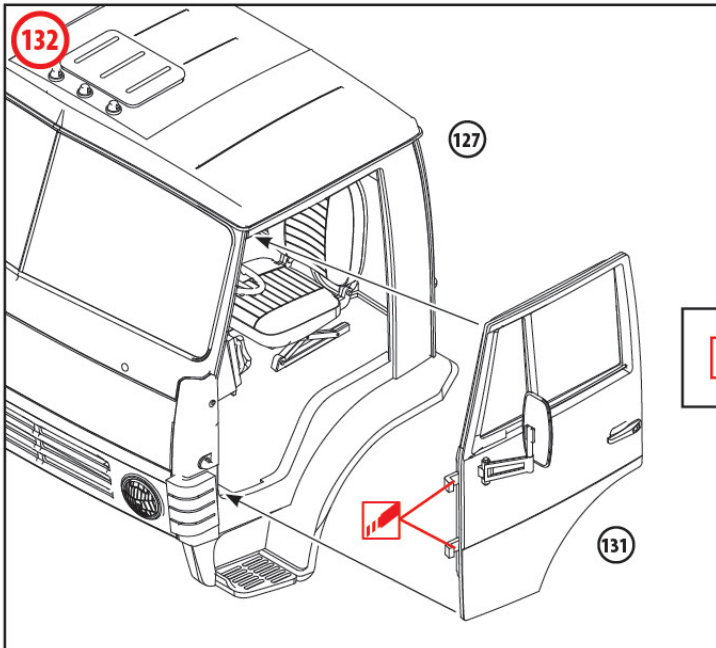
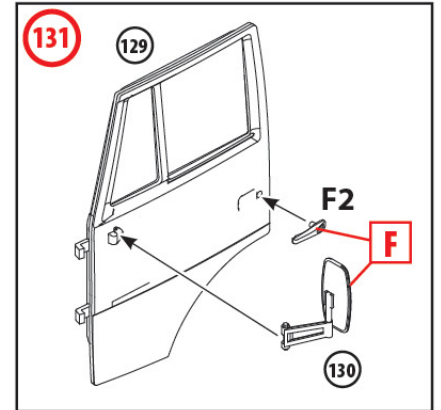
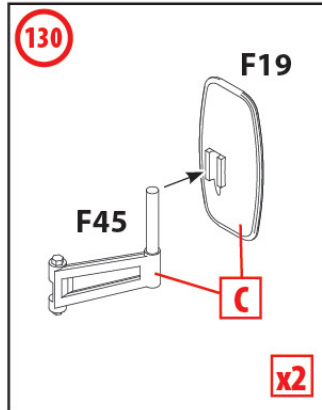
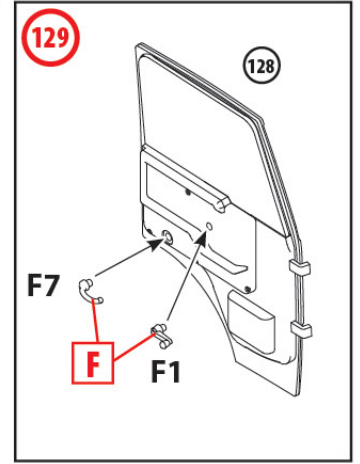
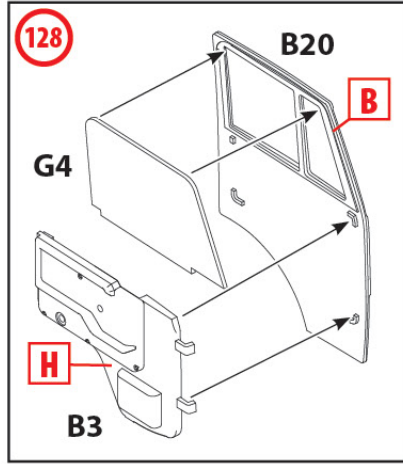
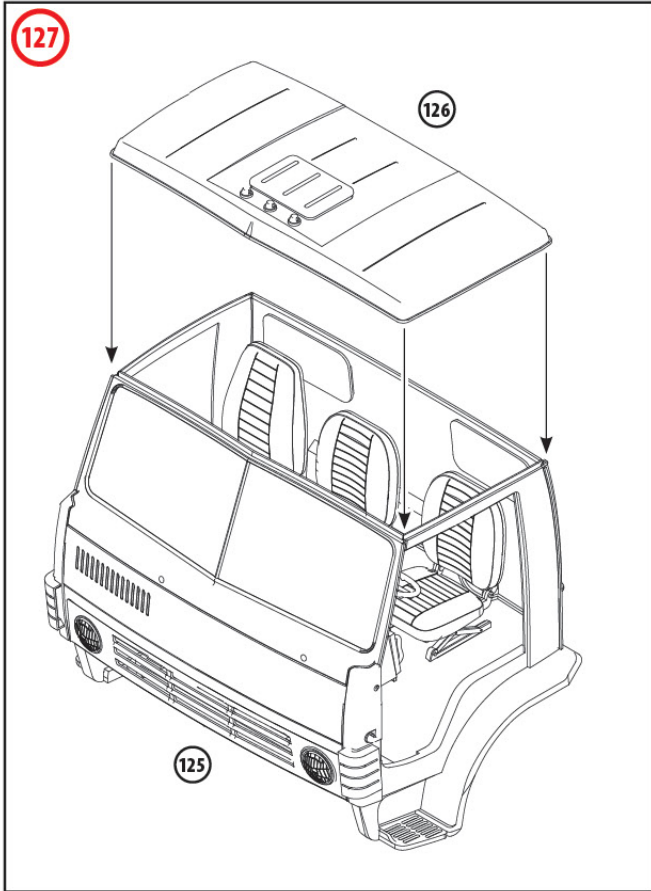

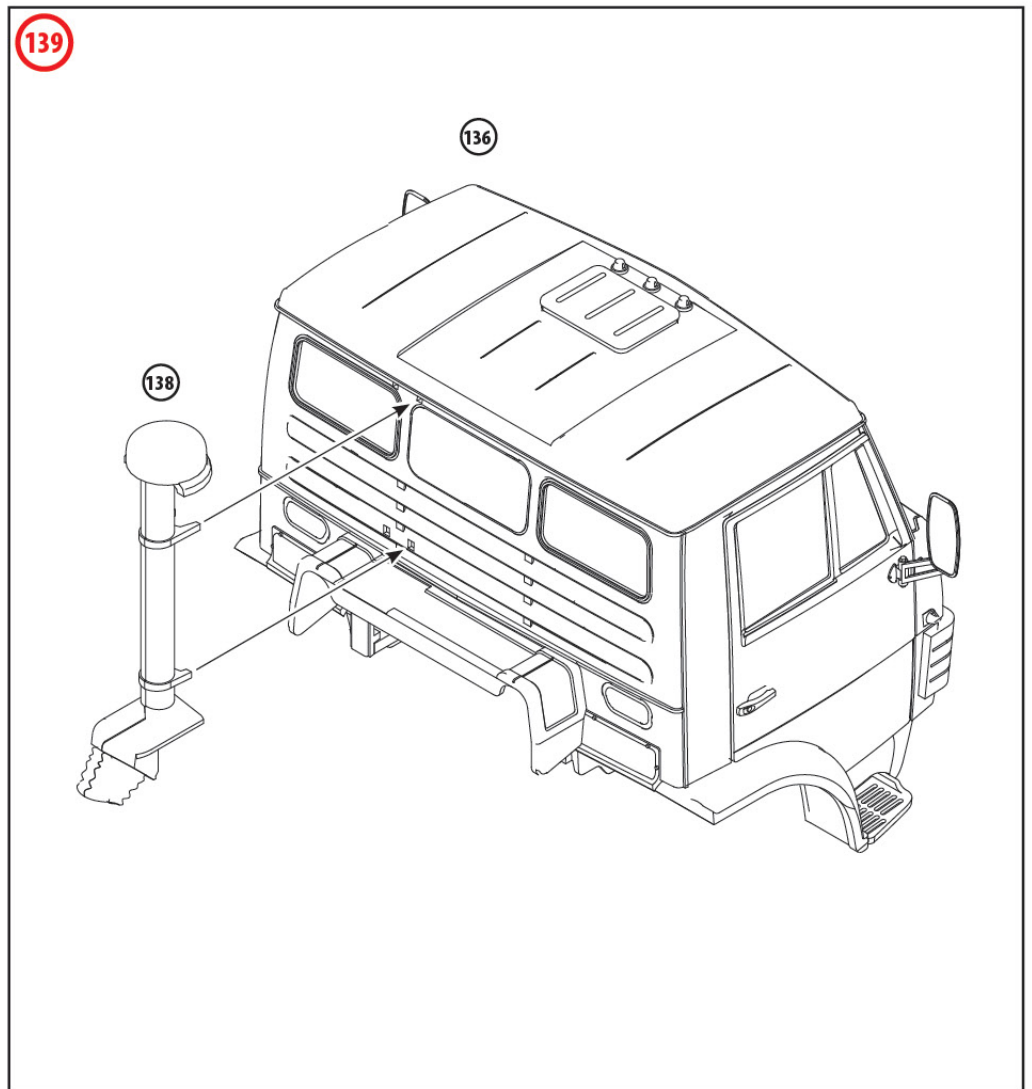
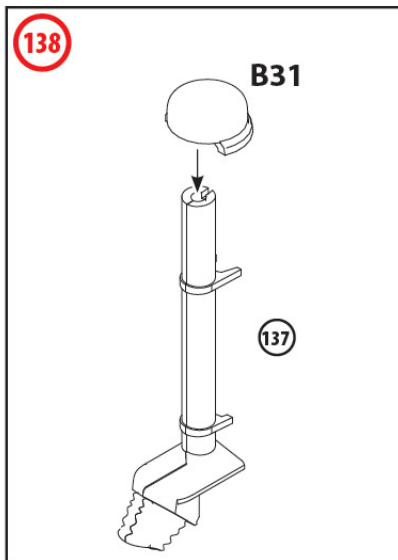
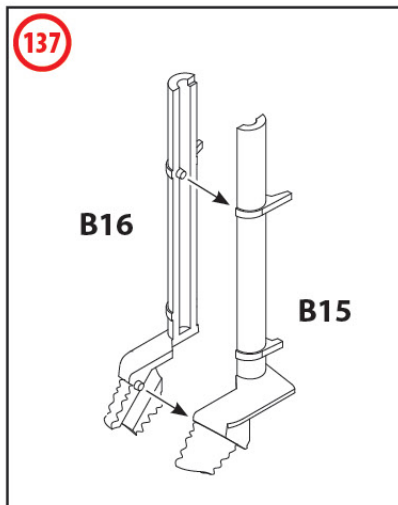
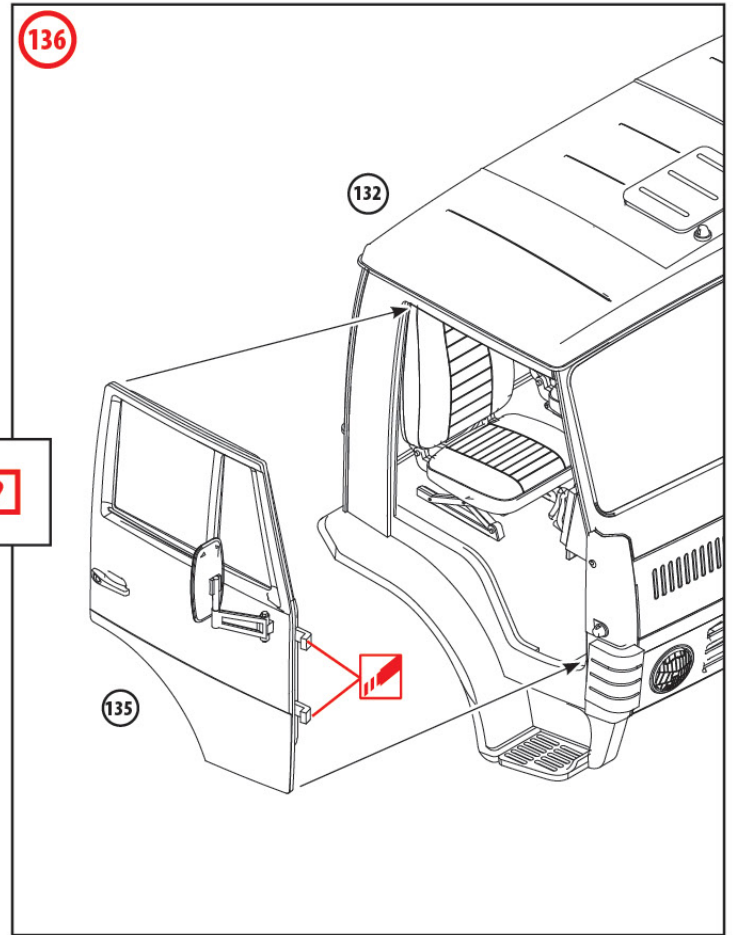
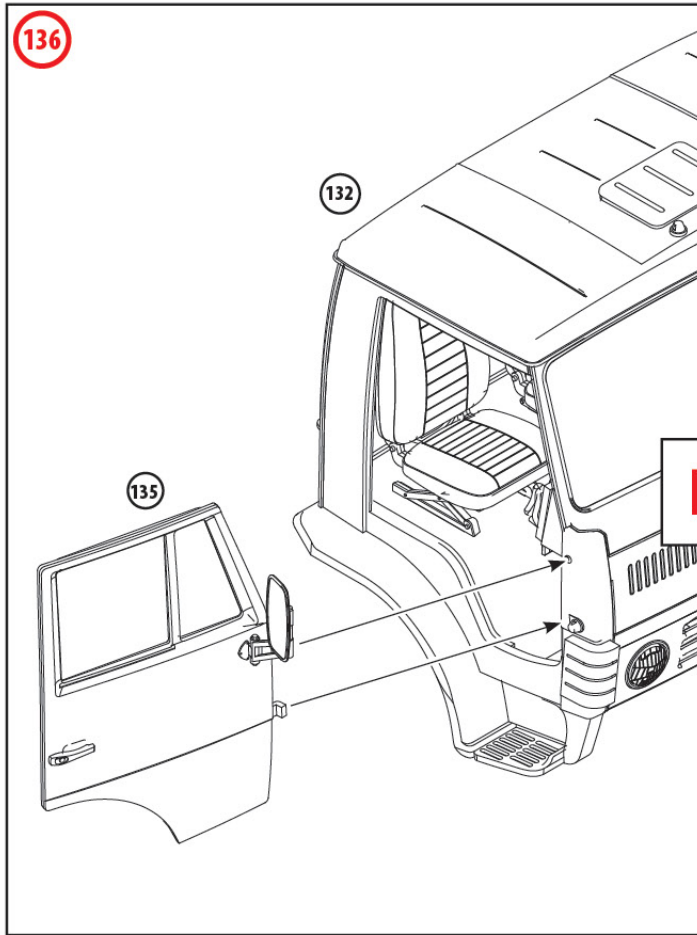

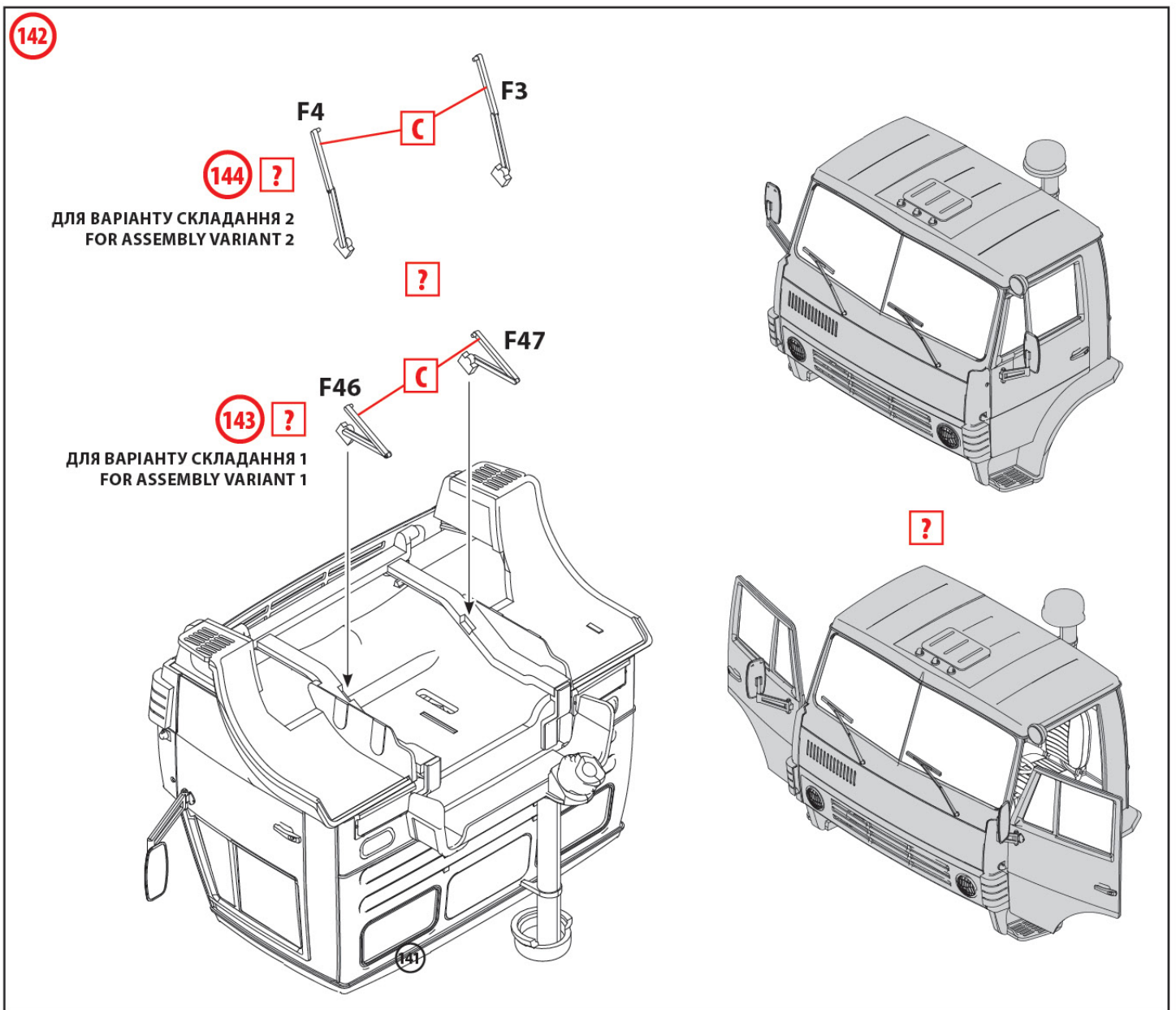
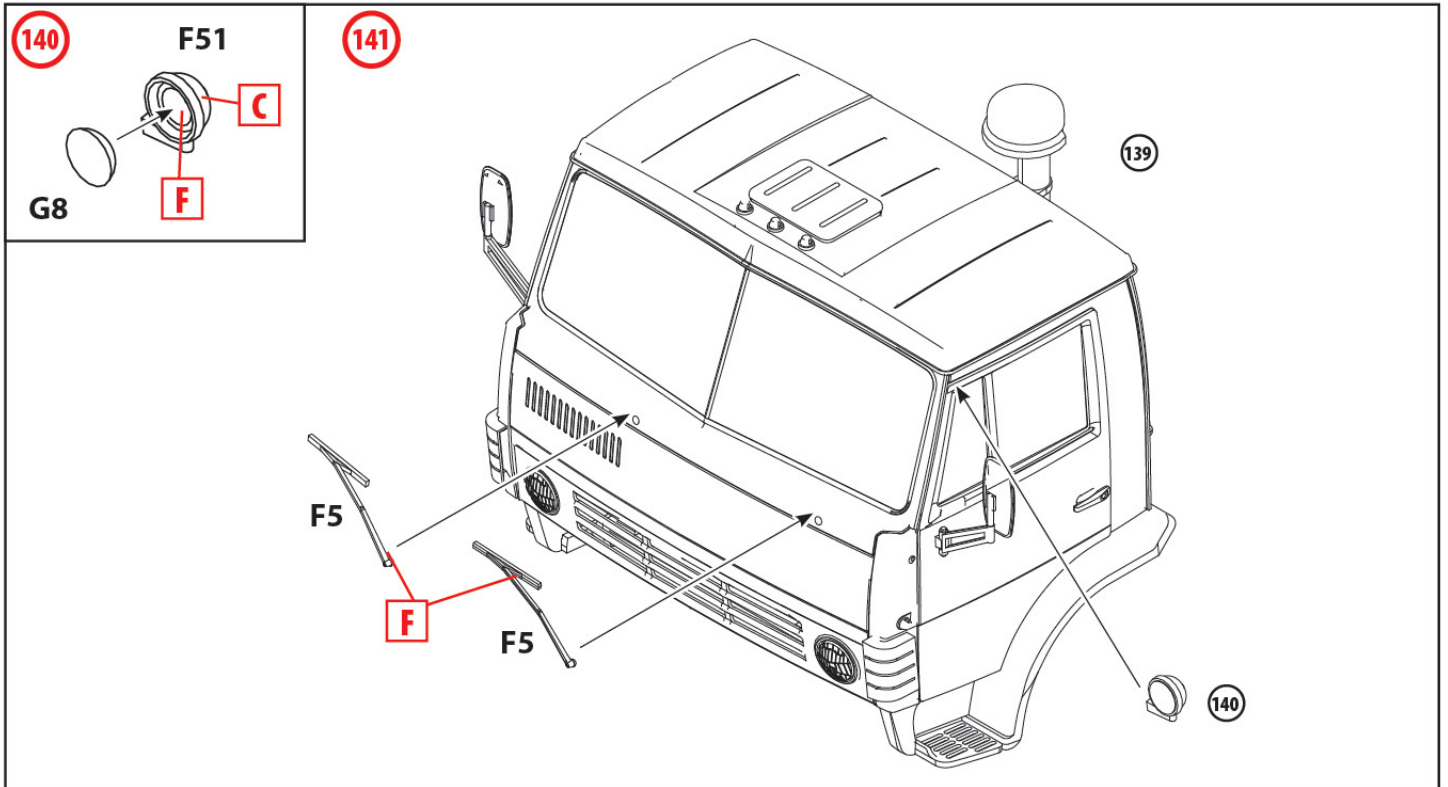

143 **?** ВАРИАНТ СКЛАДАННЯ 1
ASSEMBLY VARIANT 1

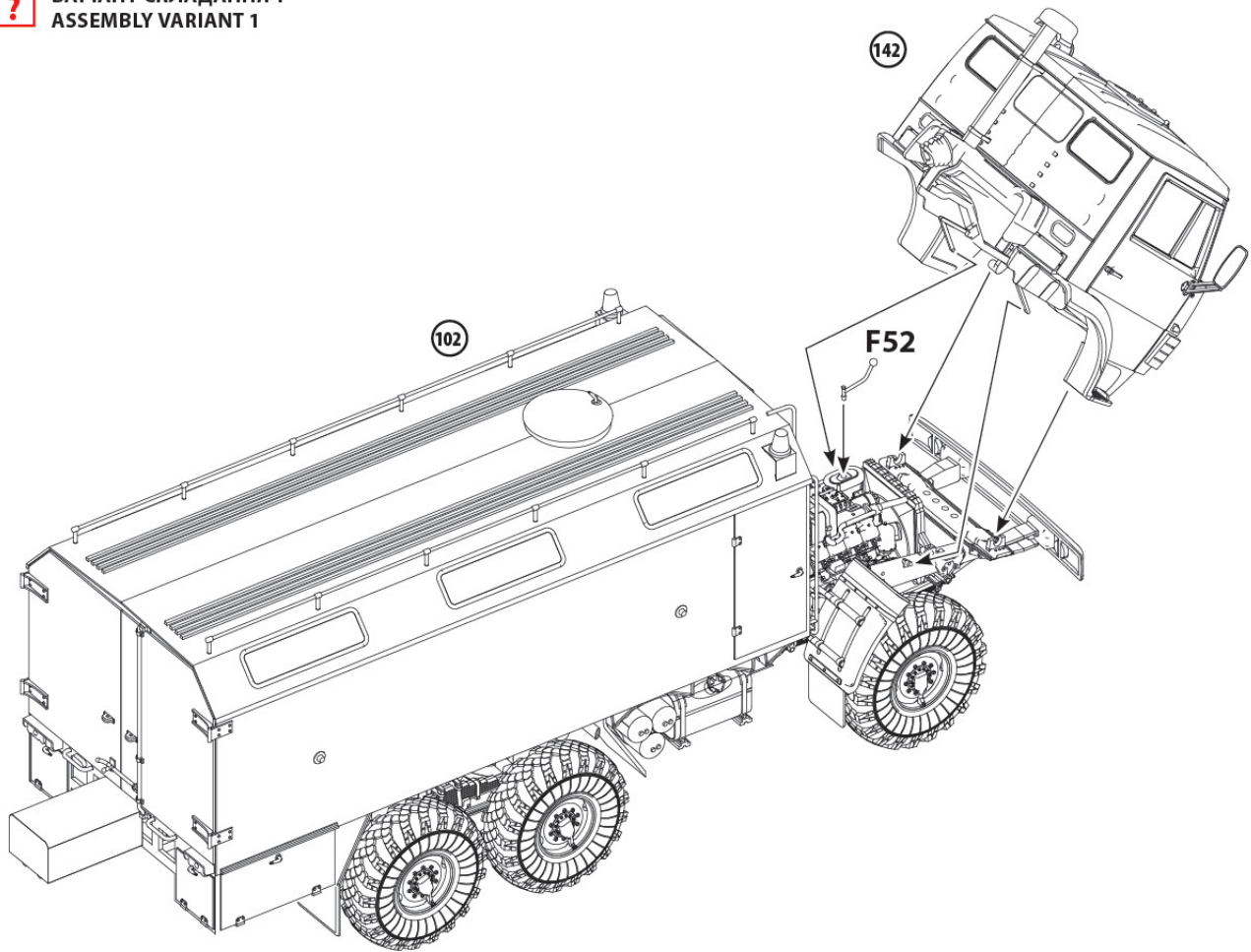

144 **?** ВАРИАНТ СКЛАДАННЯ 2
ASSEMBLY VARIANT 2

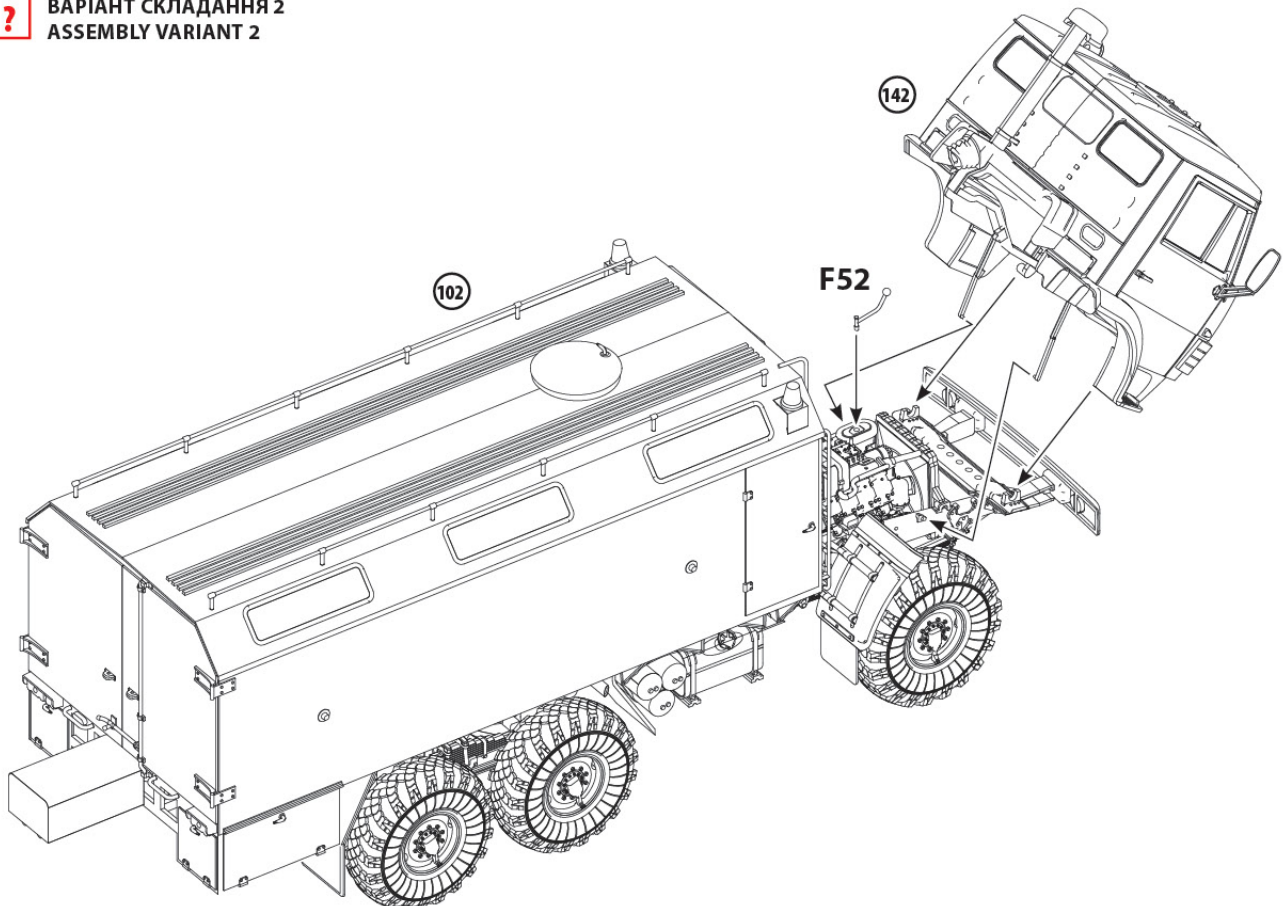

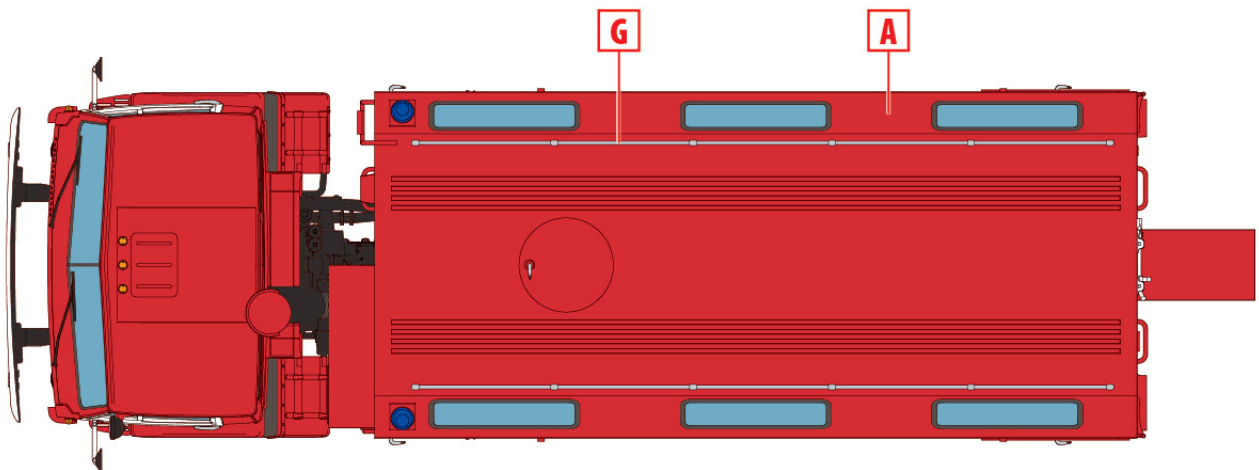
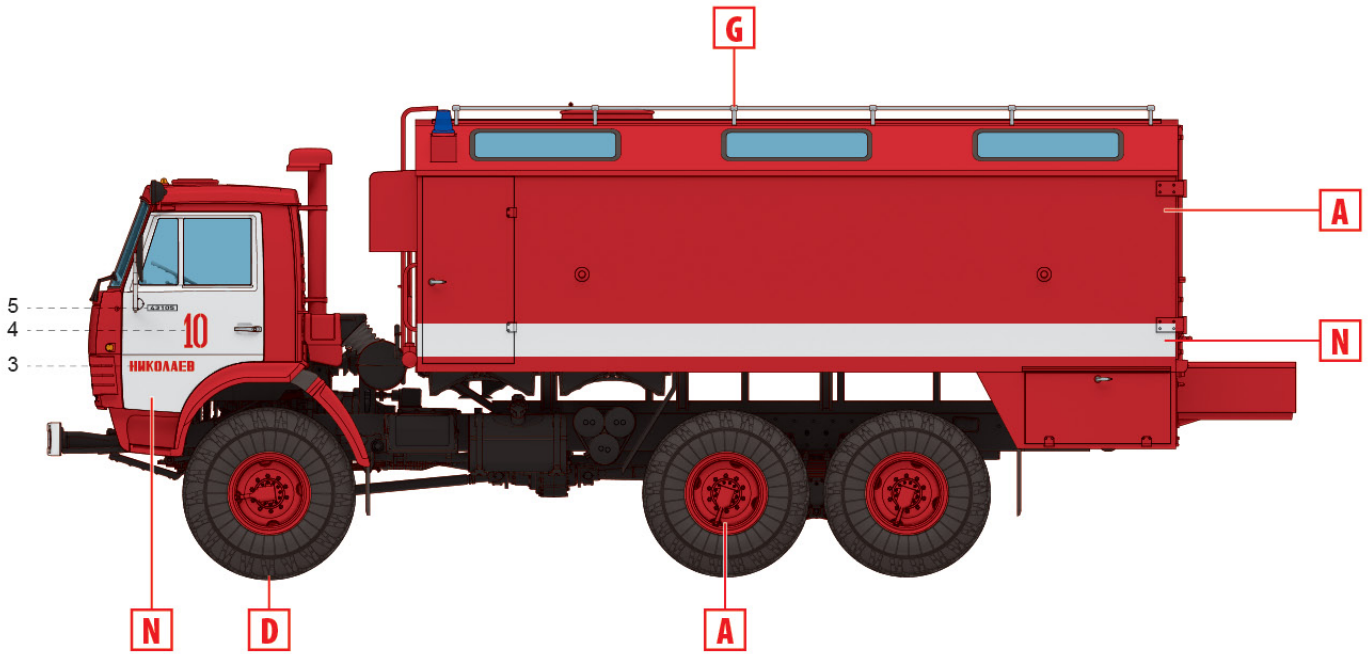
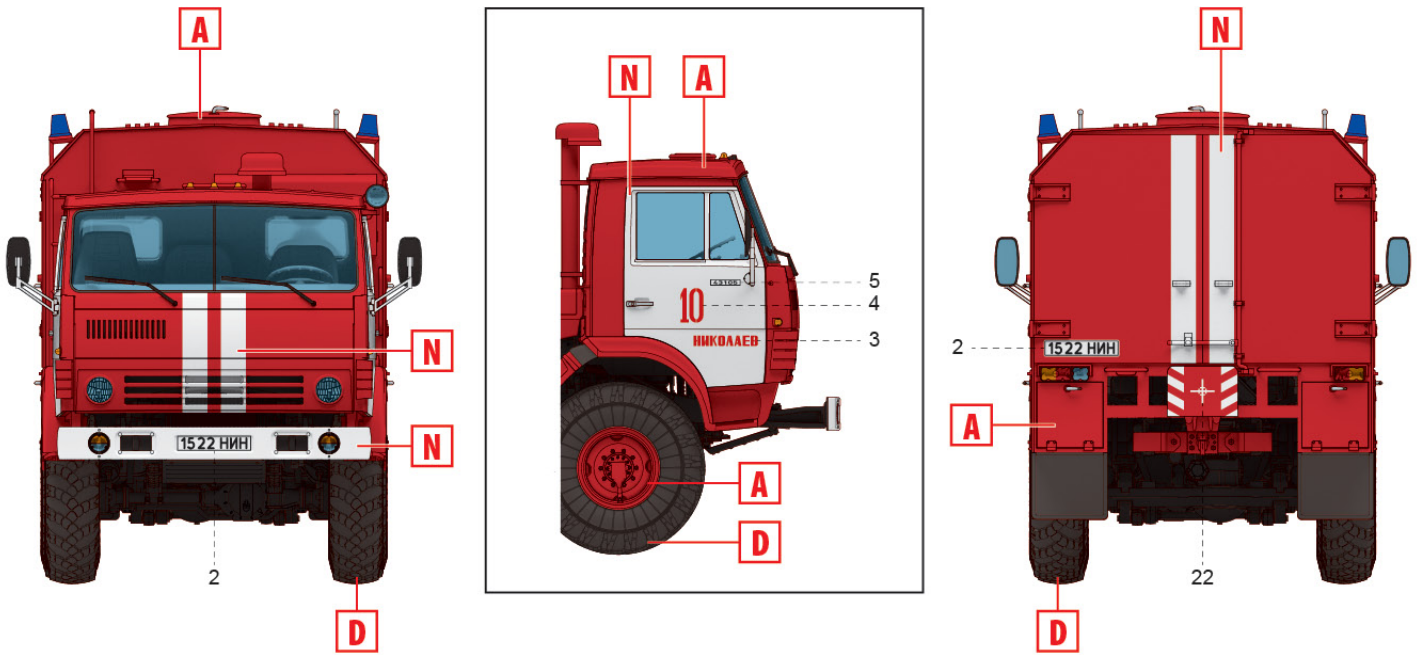

1. AP-2(43105)-215, Миколаїв, початок 1990-х років

AR-2(43105)-215, Mykolaiv, early 1990s

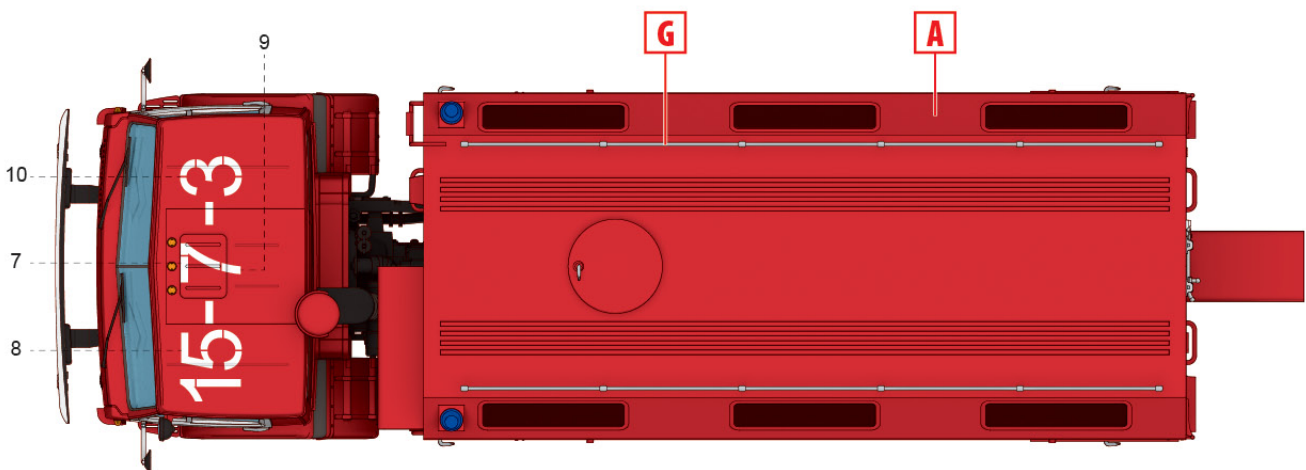
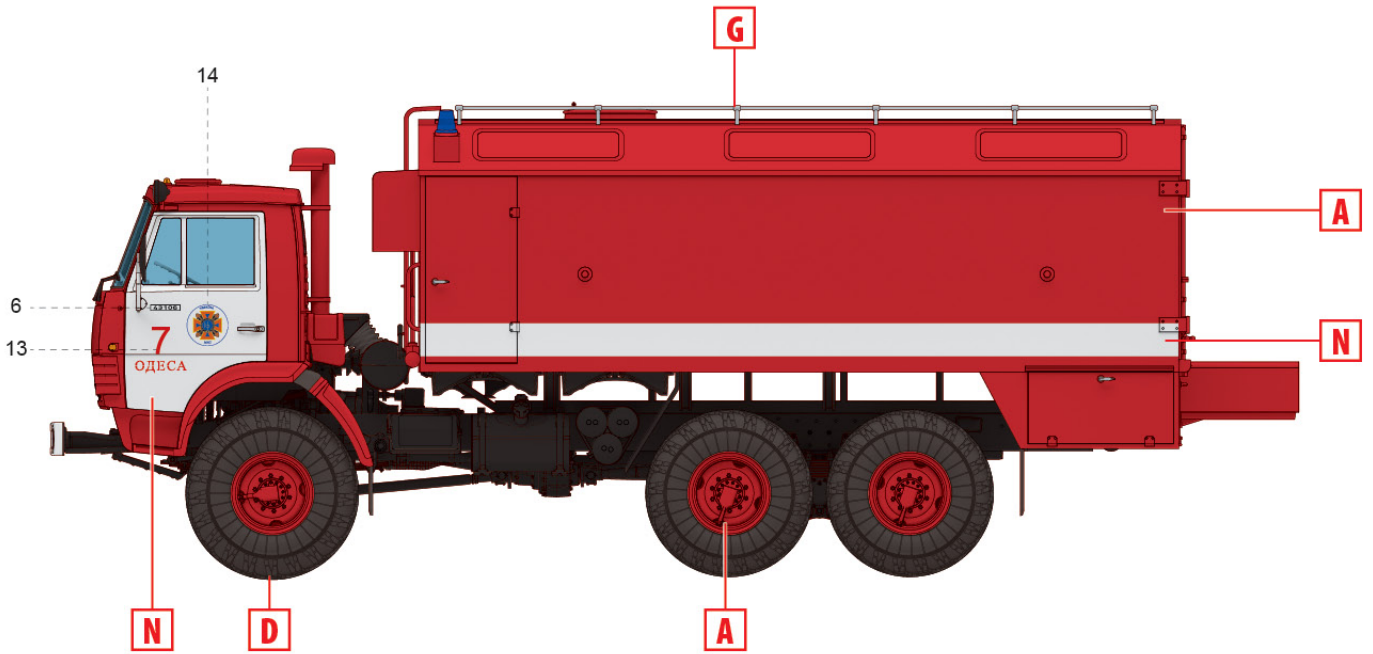
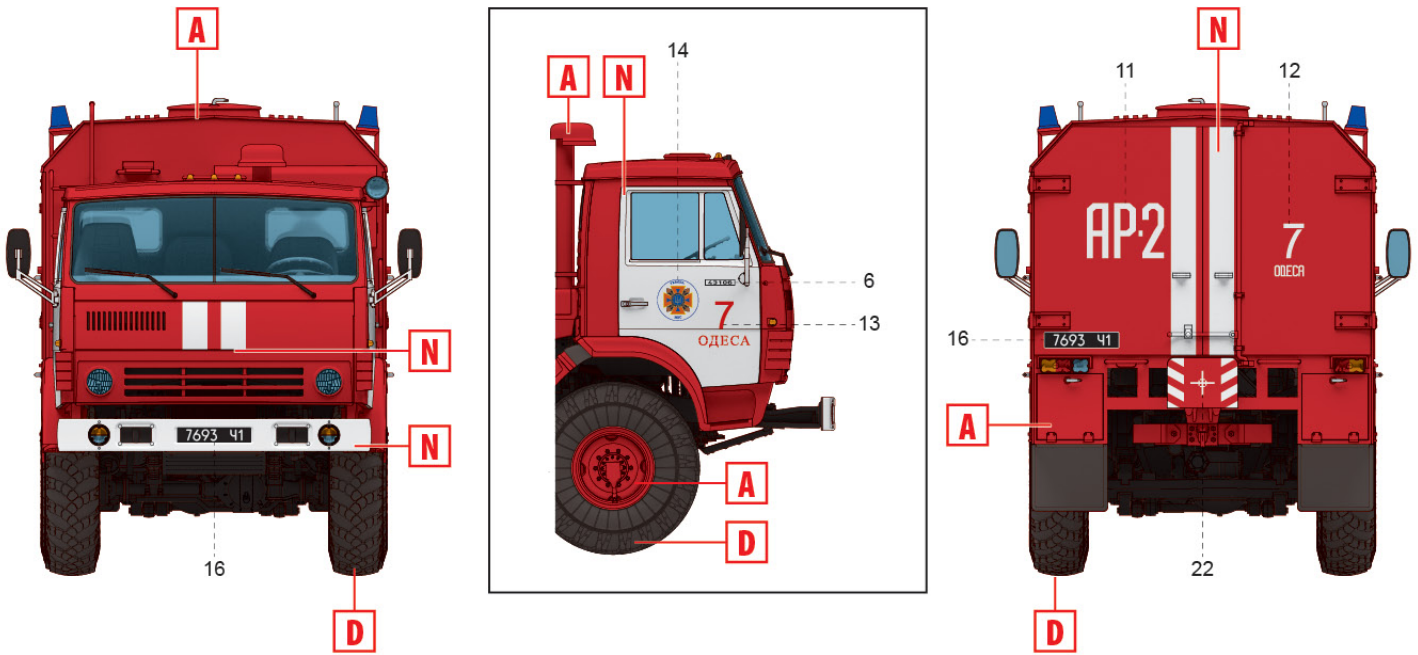

2. AP-2(43105)-215, Одеса, 2012 рік

AR-2(43105)-215, Odesa, 2012

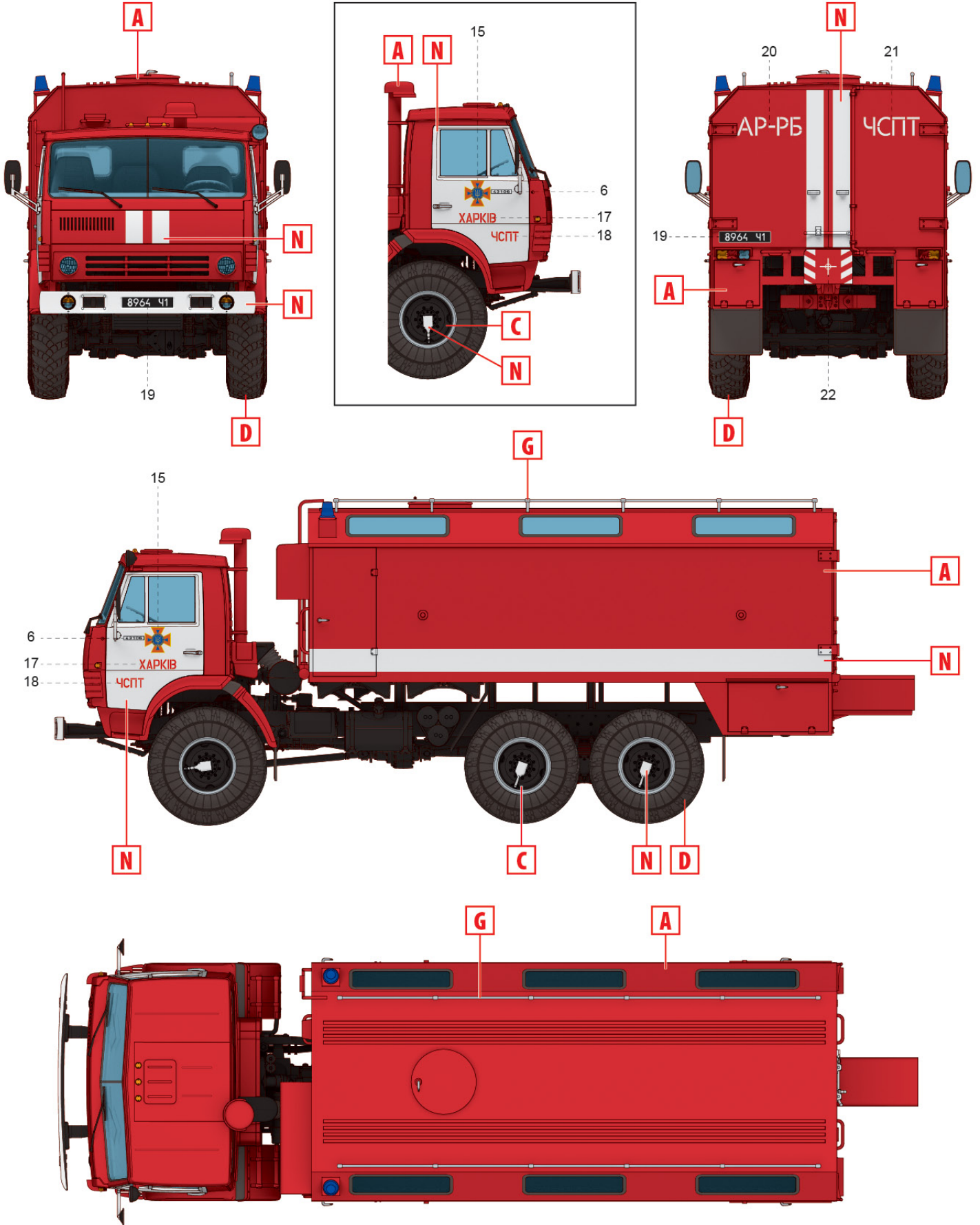

3. AP-2(43105)-215, Харків, 2015 рік

AR-2(43105)-215, Kharkiv, 2015

ТОВ ICM Холдинг

вул. Бориспільська 9, корпус 64,
02099, Київ, Україна
Тел./факс: +38(044) 369 54 12
E-mail: export@icm.com.ua

ICM Holding

9 Boryspilska str., build. 64
02099, Kyiv, Ukraine
Tel./Fax: +38(044) 369 54 12
E-mail: export@icm.com.ua