

## Boston Mk.IV/V

(EN)

A-20G was the Havoc's first mass produced version for the USAAF. Compared to earlier versions the crew was reduced to only two members and the solid nose contained boosted armament. The early production blocks from A-20G-1 to G-15 were equipped with four 20 mm M1 cannons and two 12.7mm machine guns and early enclosed dorsal gunner's station with flexible mounted machine guns. Thanks to the weight increase and the M1 cannons jamming the USAAF was not satisfied with the early aircraft performances. 250 aircraft of the early batch were eventually given to the USSR under Lend-Lease. The rest of the already produced aircraft armament changed from cannon to machine guns. From A-20G-20 the aircraft were delivered with six nose mounted 12.7 mm machine guns and electrically driven Martin turret with two 12.7 mm machine guns mounted into widened dorsal position. The subsequent production blocks were the same.

Bomber version A-20J intended for European Theatre was based on A-20G. This version received the glazed nose section for navigator-bombardier. These aircraft were also used as A-20G formation leaders.

Since the Havocs' weight increased constantly the last produced versions in Santa Monica received more powerful R-2600-29 engines. Engines were the only difference from A-20G. The ground attack version with R-2600-29 engines was designated A-20H and bomber version A-20K.

USAAF deployed A-20Gs to both European and Pacific theaters. Gunships A-20G in Pacific participated in fights over New Guinea, Philippines, Palau Islands, Thai-Wan and Okinawa. In Europe, the late versions of US Havocs participated in fights over Sicily and Italy but were mainly deployed over Western Europe from their bases in Great Britain. Except USAAF were A-20J and K Havocs used by RAF that deployed them under its own designation Boston Mk.IV (A-20J) and Boston Mk.V (A-20K) mainly over Italy. Havocs were also operated by Free French 342nd Squadron Lorraine under RAF. USSR received A-20Gs of early as so the later production blocks and assigned them to both air force units and navy units. RAAF received twenty nine A-20Gs. The Gs completed the early version of Havocs / Bostons in RAAF 22 Squadron. Several machines were destroyed during heavy Japanese air raid on November 23, 1944. The remaining A-20Gs were returned to USAAF and RAAF 22 Squadron was re-equipped with Beaufighters. Under Lend-Lease, 31 A-20K were delivered to Brazil where served up to the 1950s.

(CZ)

A-20G byla první opravdu masově vyráběnou verzí Havocu pro letectvo US Army. Oproti starším verzím byla redukována osádka na dva členy, předtím byla zaplechována a byla do ní soustředěna zesílená hlavní výzbroj. První výrobní bloky A-20G-1 až G-15 dostaly výzbroj čtyř kanonů M1 a dvou kulometů ráže 12,7 mm a měly ještě původní provedení nekrytého střeliště. Protože došlo k nárůstu hmotnosti, a kanony M1 se při delších dávkách zasekávaly, nebylo s výkony prvních A-20G letectvo US Army spokojeno. Dvěšestpadesát kusů této verze dostal Sovětský svaz. U ostatních strojů byly kanony nahrazeny kulomety. Nejpozději od výrobního bloku A-20G-20 byly dodávány Havocy standardně s šesti kulomety ráže 12,7 mm v přední a s do rozšířeného trupu instalovanou střeleckou věží Martin se dvěma kulomety ráže 12,7 mm. Další bloky byly shodné.

Na základě bitevní verze A-20G byla pro evropské bojiště vyráběna bombardovací verze A-20J. Ta se vrátila k prosklené přední s pracovištěm navigátora-bombometčíka. Tyto letouny byly používány i jako vedoucí stroje pro formace A-20G.

Protože hmotnost Havoců neustále rostla, poslední verze vyráběné závodem v Santa Monice dostaly silnější variantu motorů R-2600-29. Kromě motorů se od A-20G a A-20J neodlišovaly. Bitevní verze s motory R-2600-29 dostala označení A-20H, bombardovací pak A-20K.

A-20G nasadilo letectvo US Army jak na evropském, tak pacifickém bojišti. V Pacifiku gunshipy A-20G zúčastnily bojů na N. Guineji, Filipínách, Palauských ostrovech, Tchaj-wanu a Okinavě. V Evropě se americké A-20 posledních verzí dostaly do bojů na Sicílii a Itálii, ale zejména byly masově nasazeny nad západní Evropou ze základen ve Velké Británii. Mimo letectvo US Army používalo Havocy verze A-20J a K RAF. To je nasadilo pod označením Boston Mk.IV (A-20J) a Boston Mk.V (A-20K) hlavně v Itálii. S Havocy také operovala 342. peruť Svobodných Francouzů Lorraine bojující v rámci RAF. Sovětský svaz dostal Havocy A-20G jak prvních tak i pozdějších výrobních bloků a intenzivně je nasadil v rámci sovětského letectva i leteckých jednotek sovětského námořnictva. RAAF převzalo dvacet devět strojů A-20G. A-20G doplnily starší stroje Havoc/Boston u 22. sq. RAAF. Při těžkém japonském náletu 23. 11. 1944 byla část strojů zničena. Zbýlé A-20G byly vráceny US Army a 22. sq. RAAF byla přezbrojena na Beaufightery. Brazílie dostala v rámci zákona Lend-Lease třicet jedna kusů A-20K, které sloužily až do poloviny padesátých let.

PARTS LIST 1/2

**A**

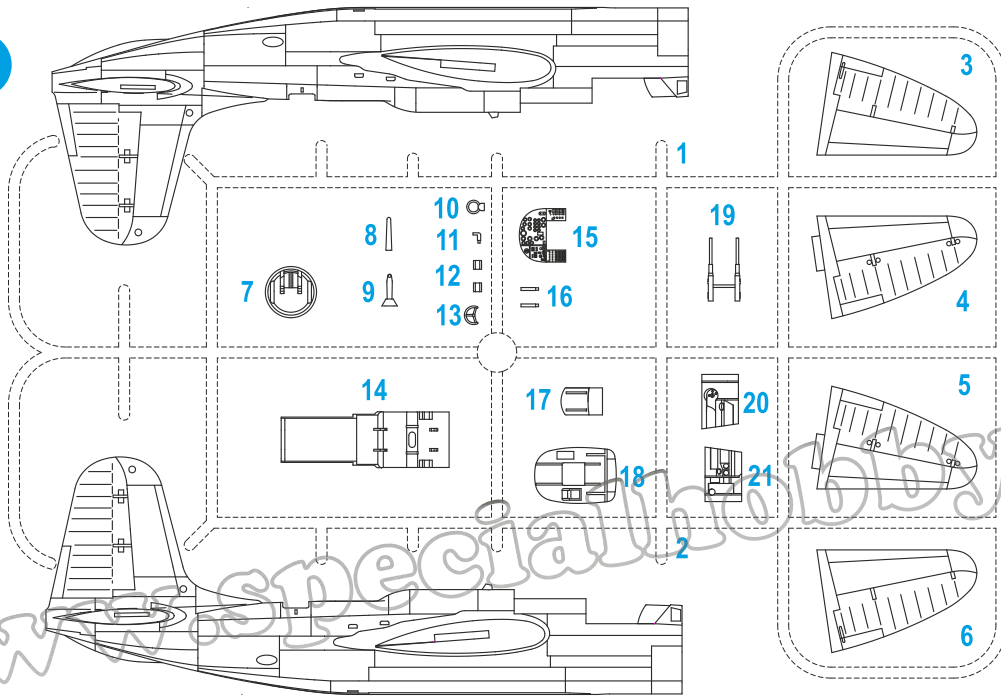

**B**

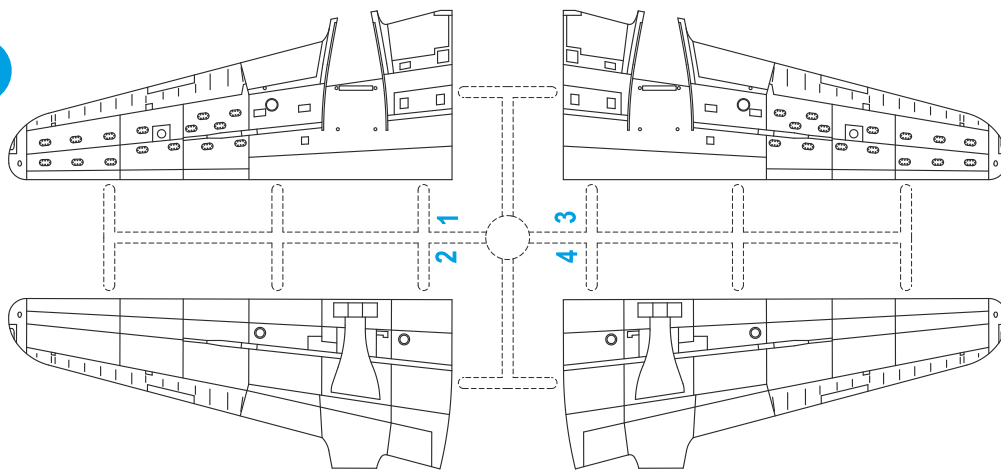

**C**

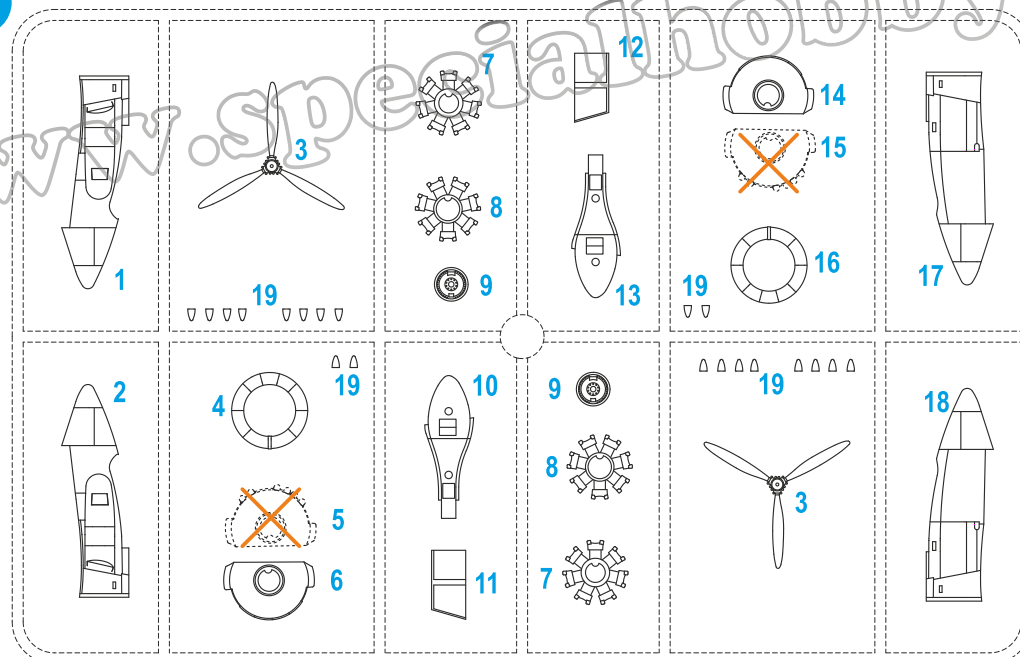

not to be used  
**X**

PARTS LIST 2/2

**D**

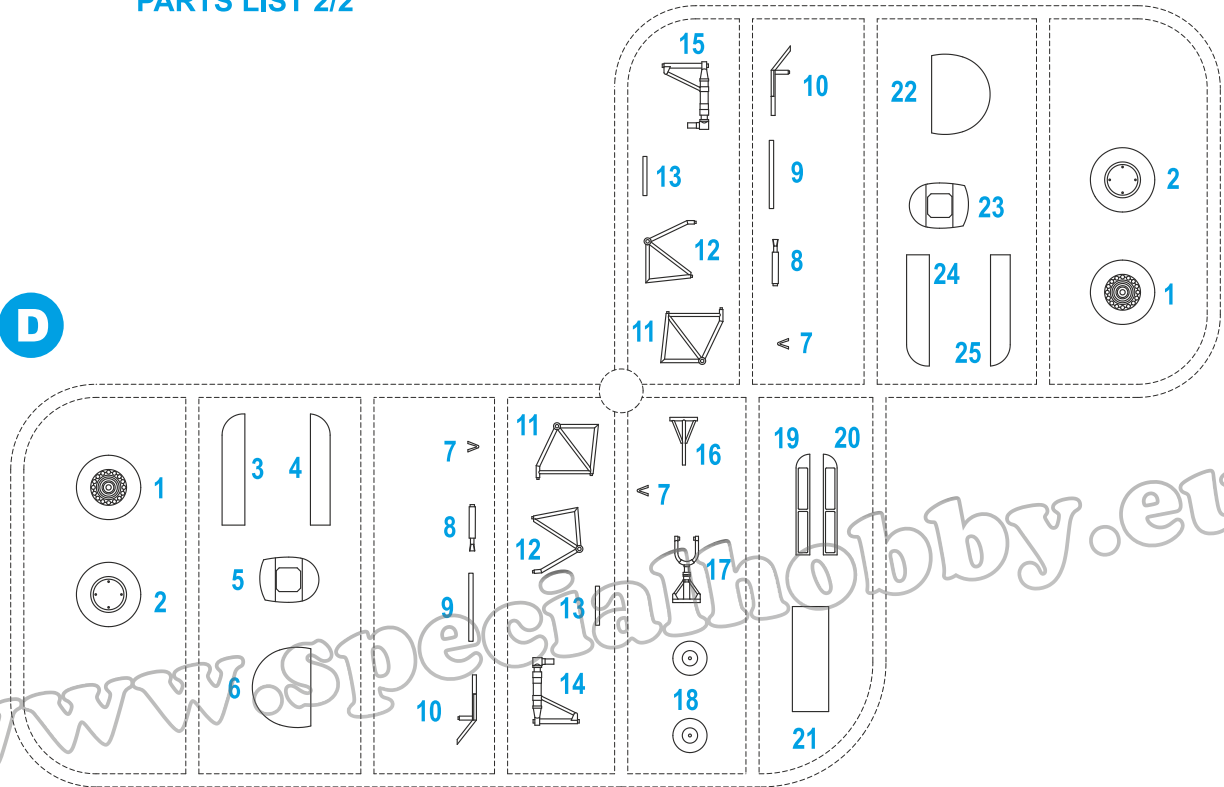

**P**

**K**

**F**

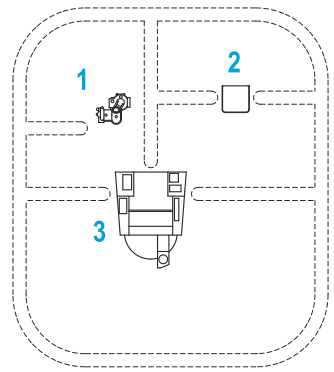
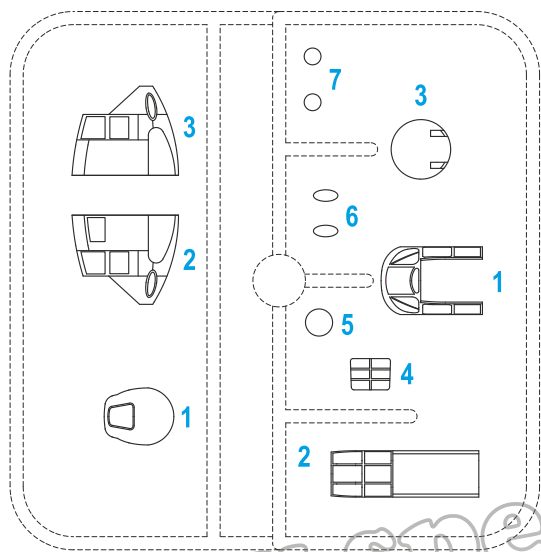

**Barvy GUNZE/ GUNZE Colour No.**

<b>A</b>	Flat Black / černá matná	H12/C33
<b>B</b>	Aluminium / hliník	H8/C8
<b>C</b>	Interior Green / zelená interiér.	H57/C27
<b>D</b>	Burnt Metal / opálený kov	H61/C76
<b>E</b>	Tire Black / barva pneu	H77/C137
<b>F</b>	Dark Iron / tmavý kov	MC214
<b>G</b>	Grayish Blue / modrošedá	H337/C337
<b>H</b>	Clear Red / červená čirá	H90/C47
<b>I</b>	Clear Green / zelená čirá	H94/C138
<b>J</b>	Black / černá	H2/C2
<b>K</b>	Yellow / žlutá	H4/C4

**?** OPTIONAL  
MOŽNOST VOLBY  
NACH BELIEBEN  
OPTION

**💧** INSTANT CYANOACRYLATE GLUE  
POUŽÍT KYANOAKRYLÁTOVÉ LEPIDLO  
ZYANOAKRYLÁTKLEBER  
ADHÉSIF CYANOACRYLAT

**SYMBOLS**  
**↪** BEND  
OHNOUT  
BIEGEN  
COURBER

**✋** SCRATCH BUILD  
ZHOTOVIT NOVÉ  
FERTIGSTELLEN  
ACHEVER

**✂** CUT OFF/DRILL  
ŘEZAT/VRTAT  
ENTFERNEN  
DETACHER

**GSI** **A** COLOUR  
NATRÍT  
FARBEN  
PEINDRE  
colours code

1

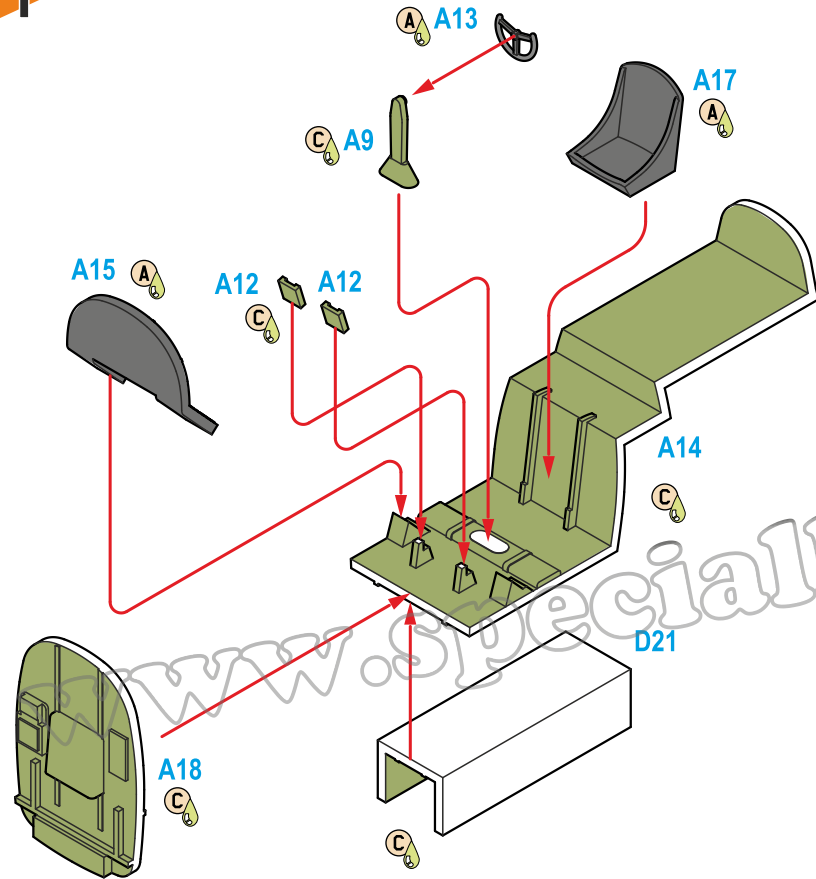

2

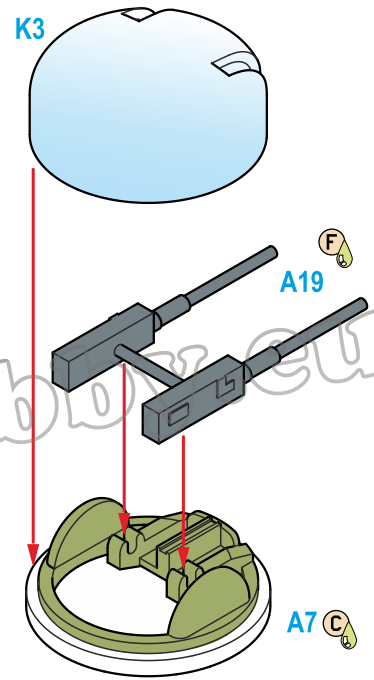

3

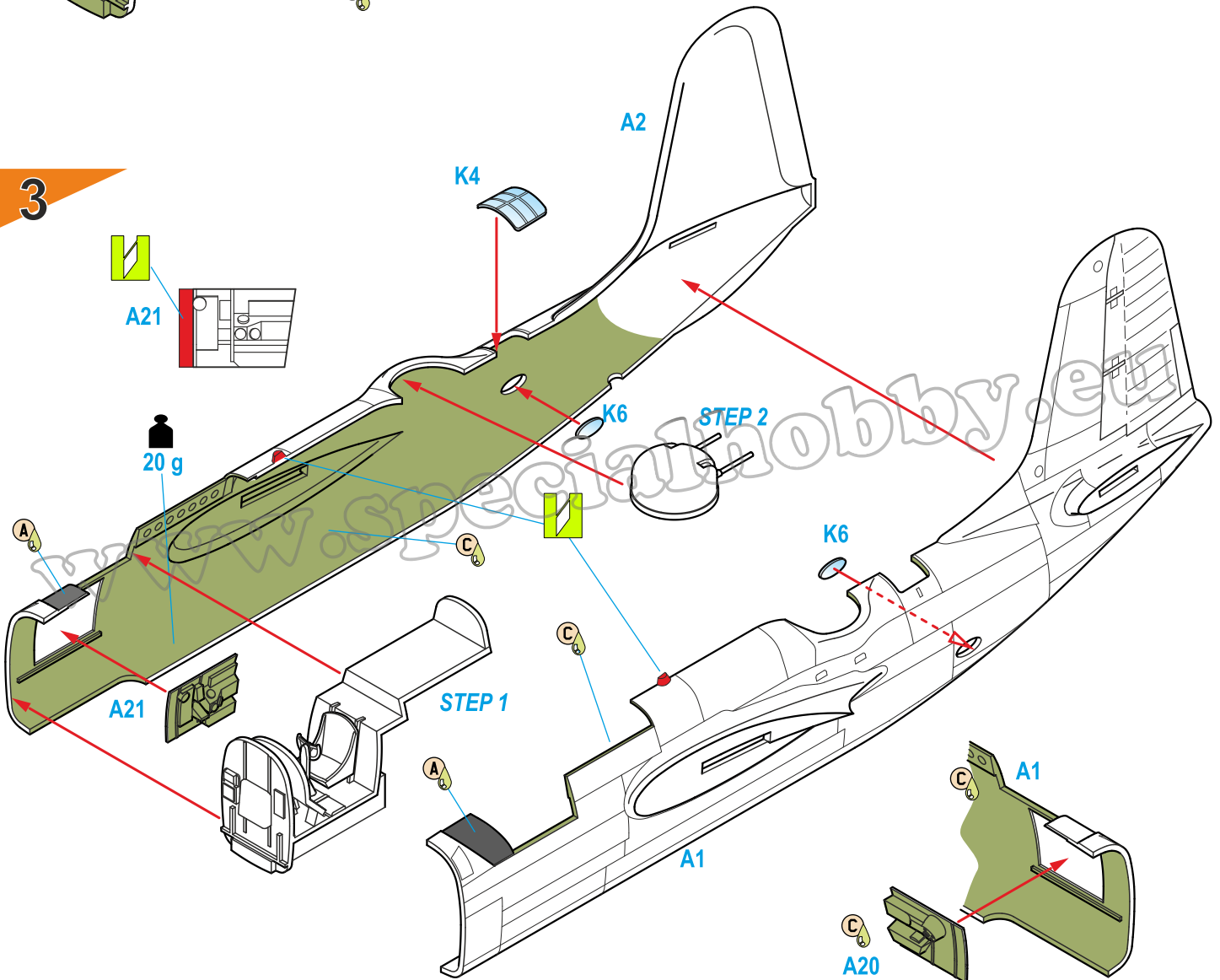

4R

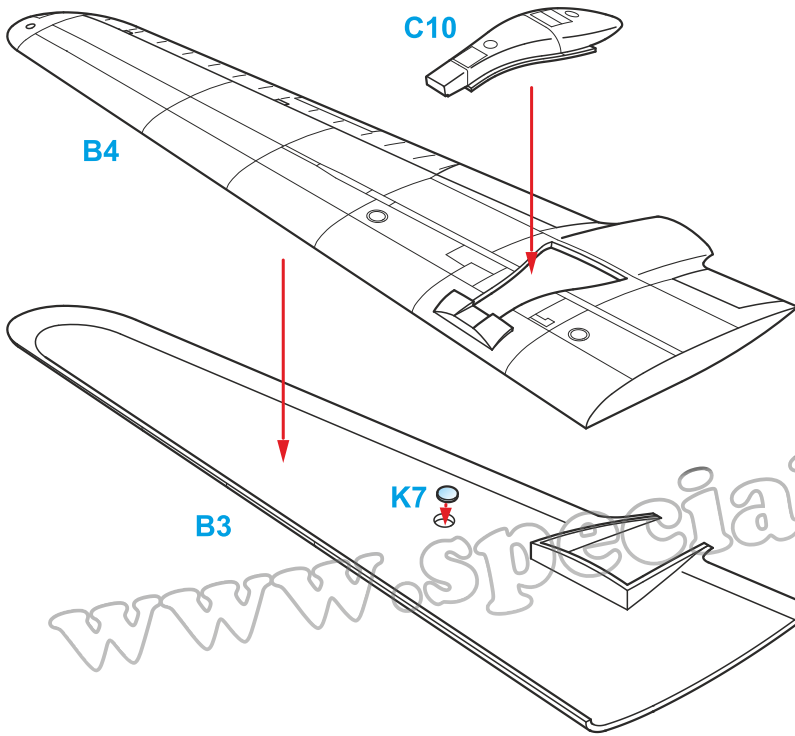

4L

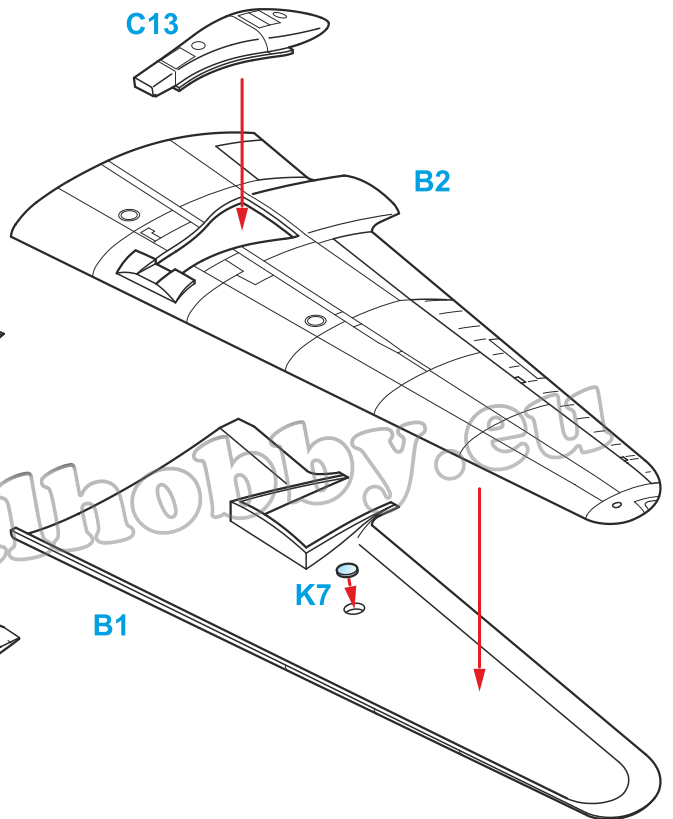

5R

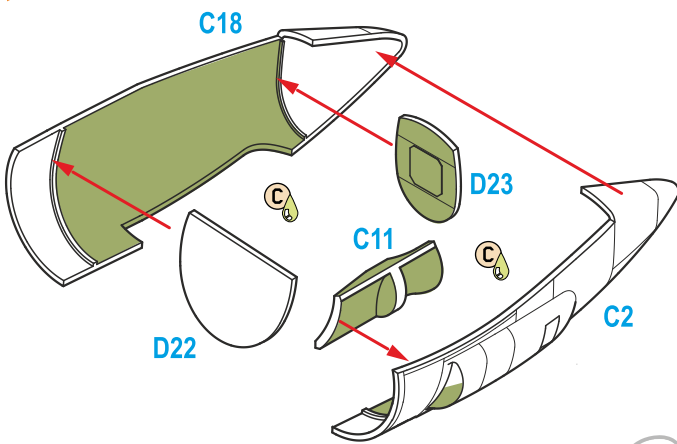

5L

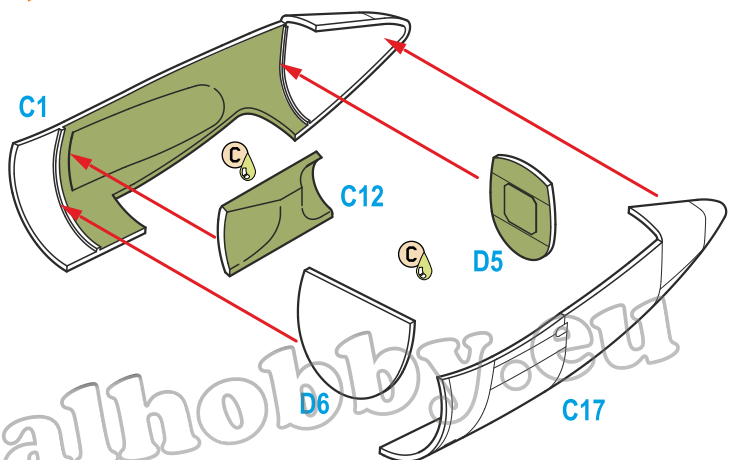

6R

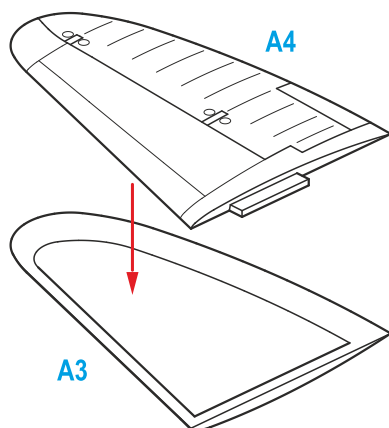

6L

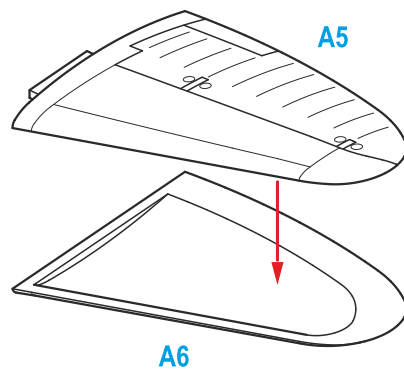

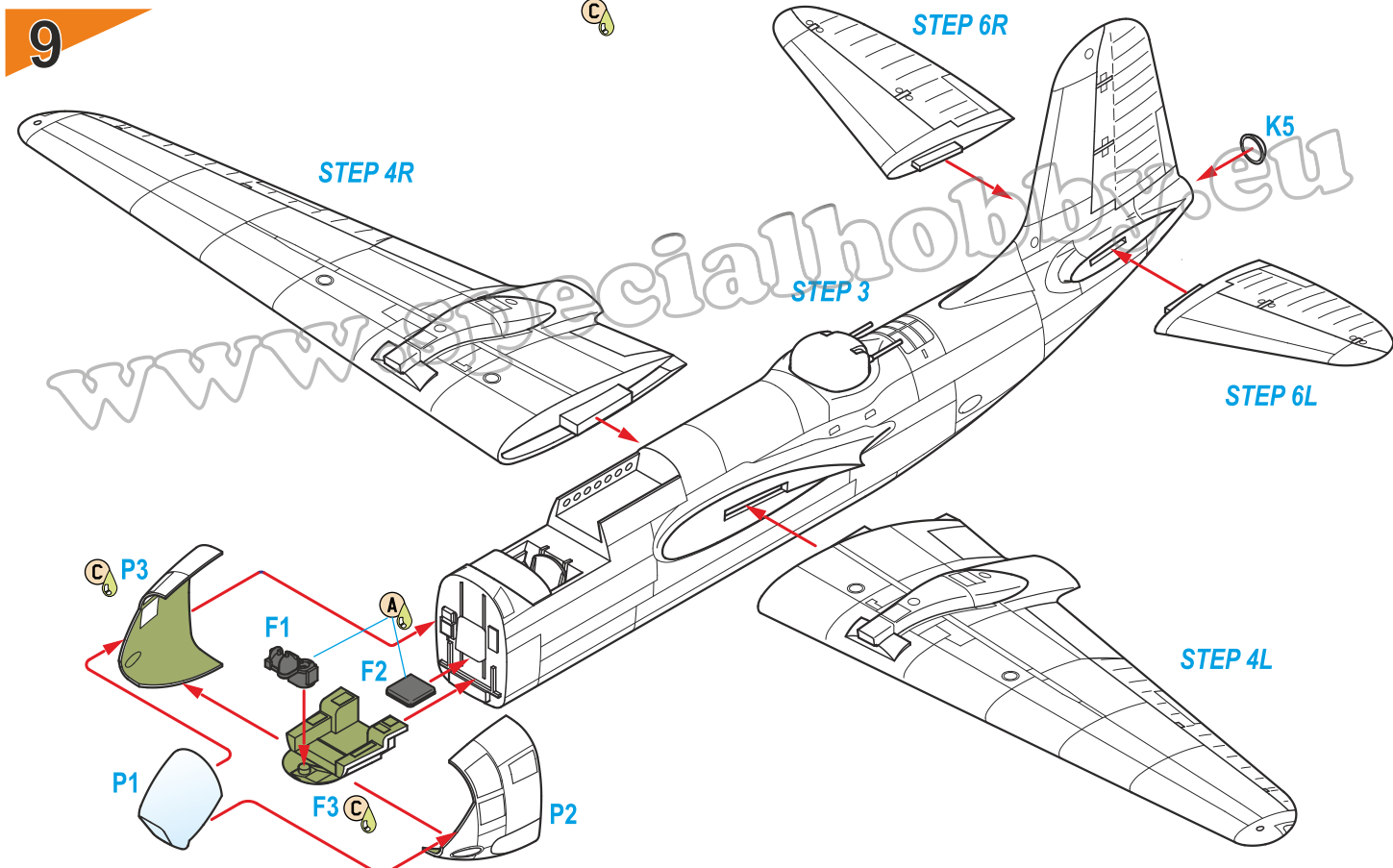
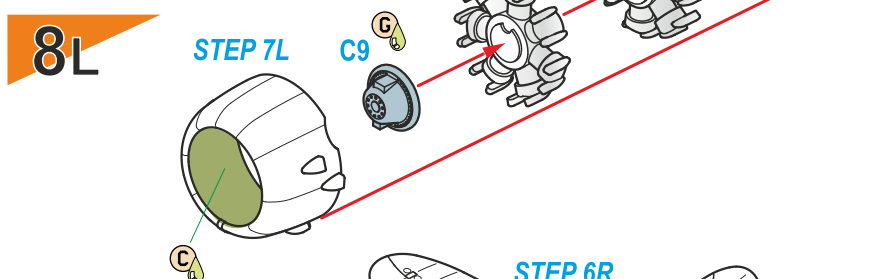
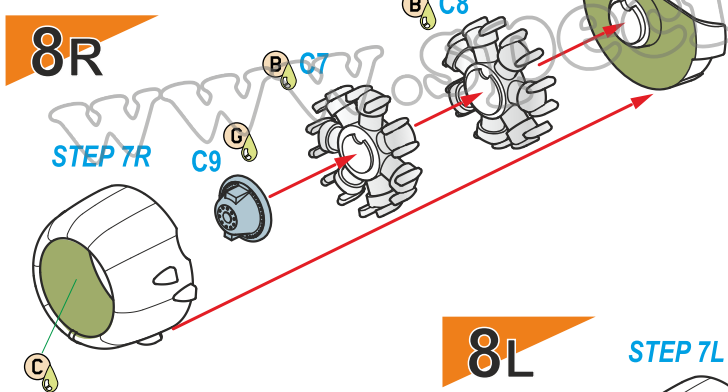
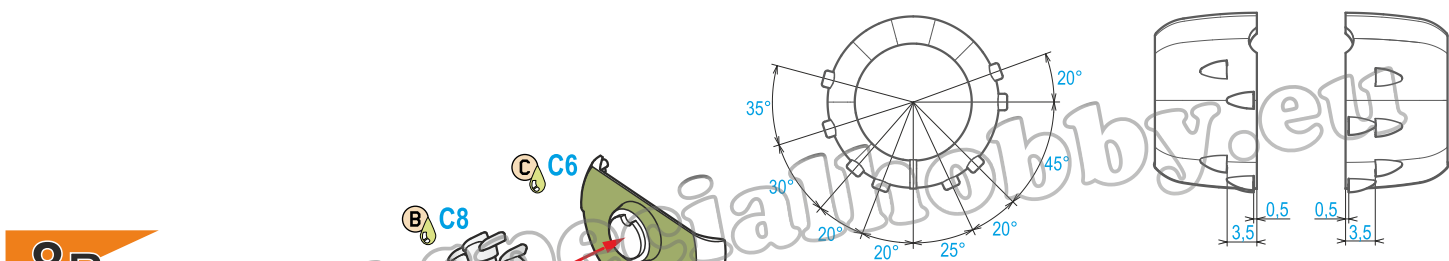
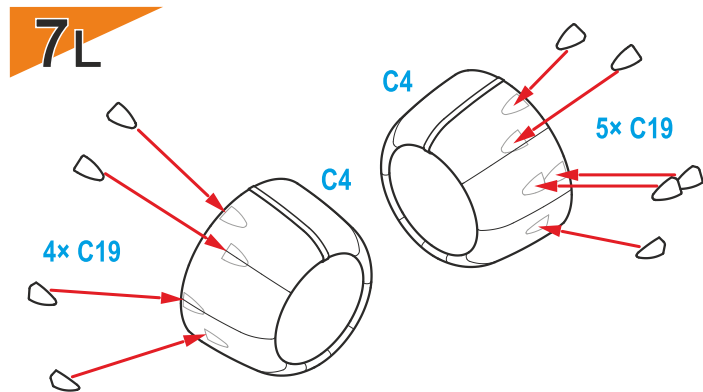
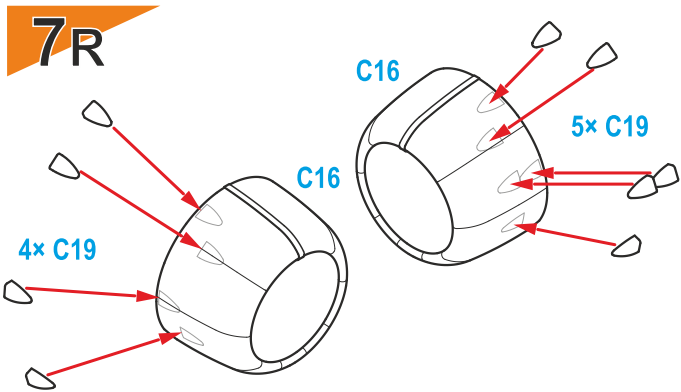

10a

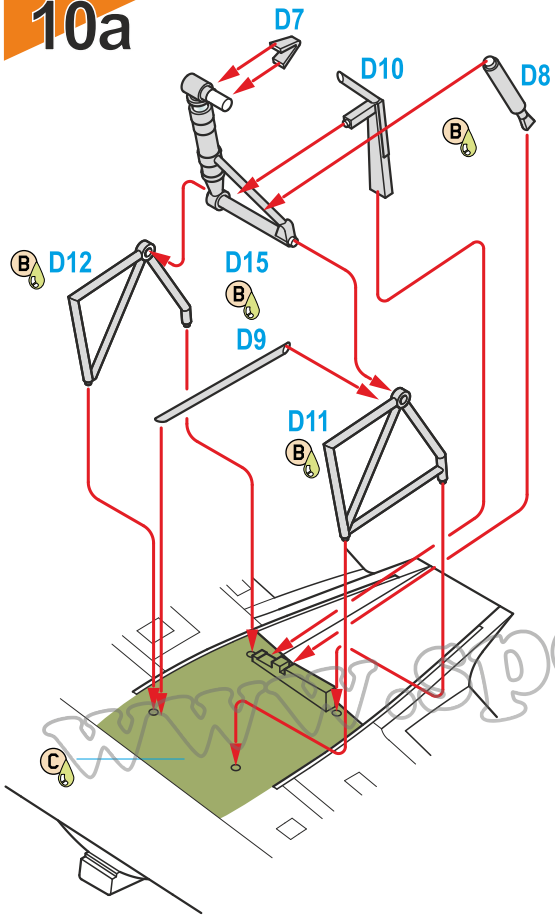

10b

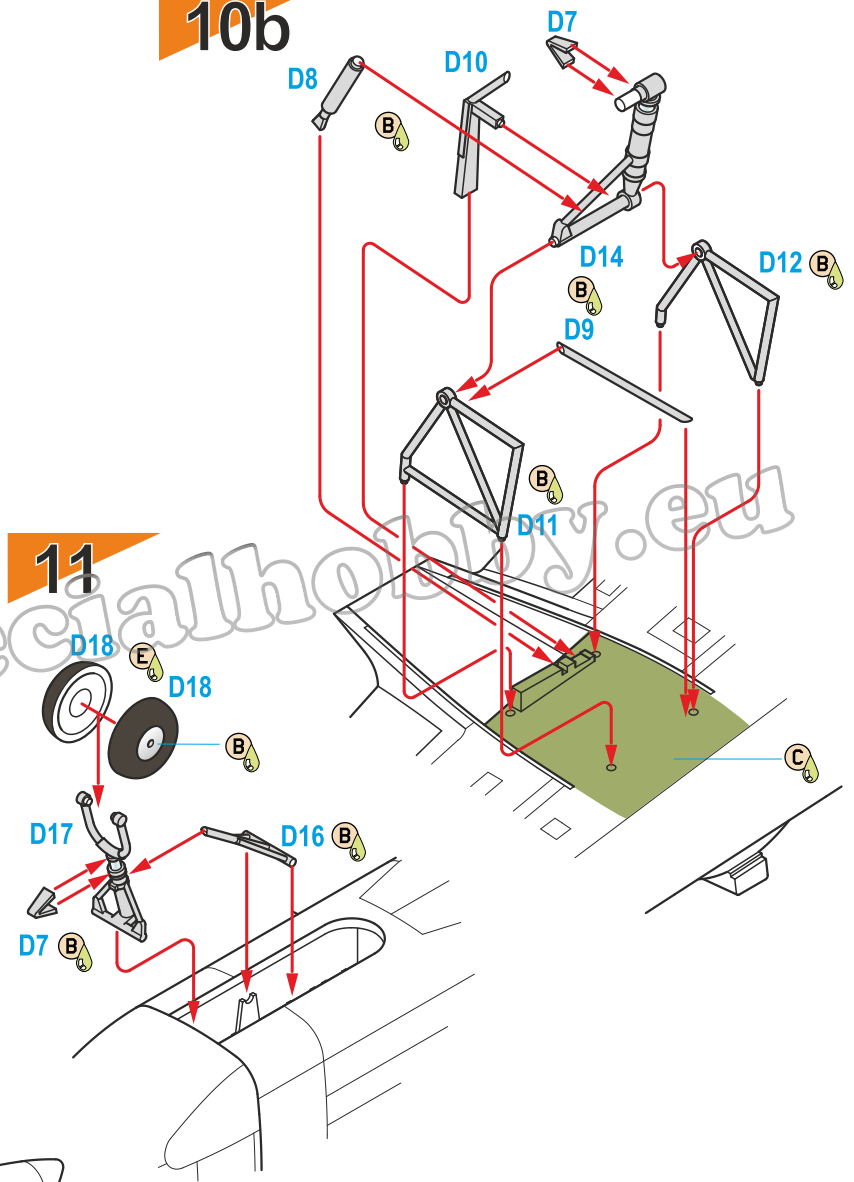

11

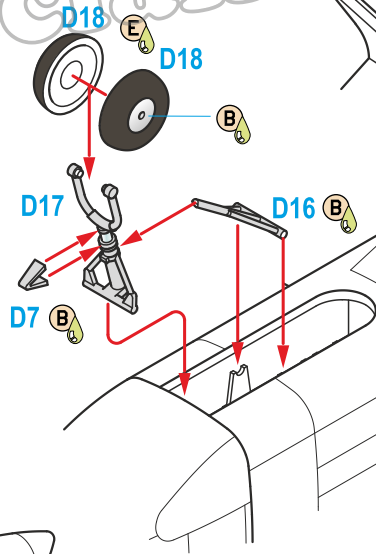

12

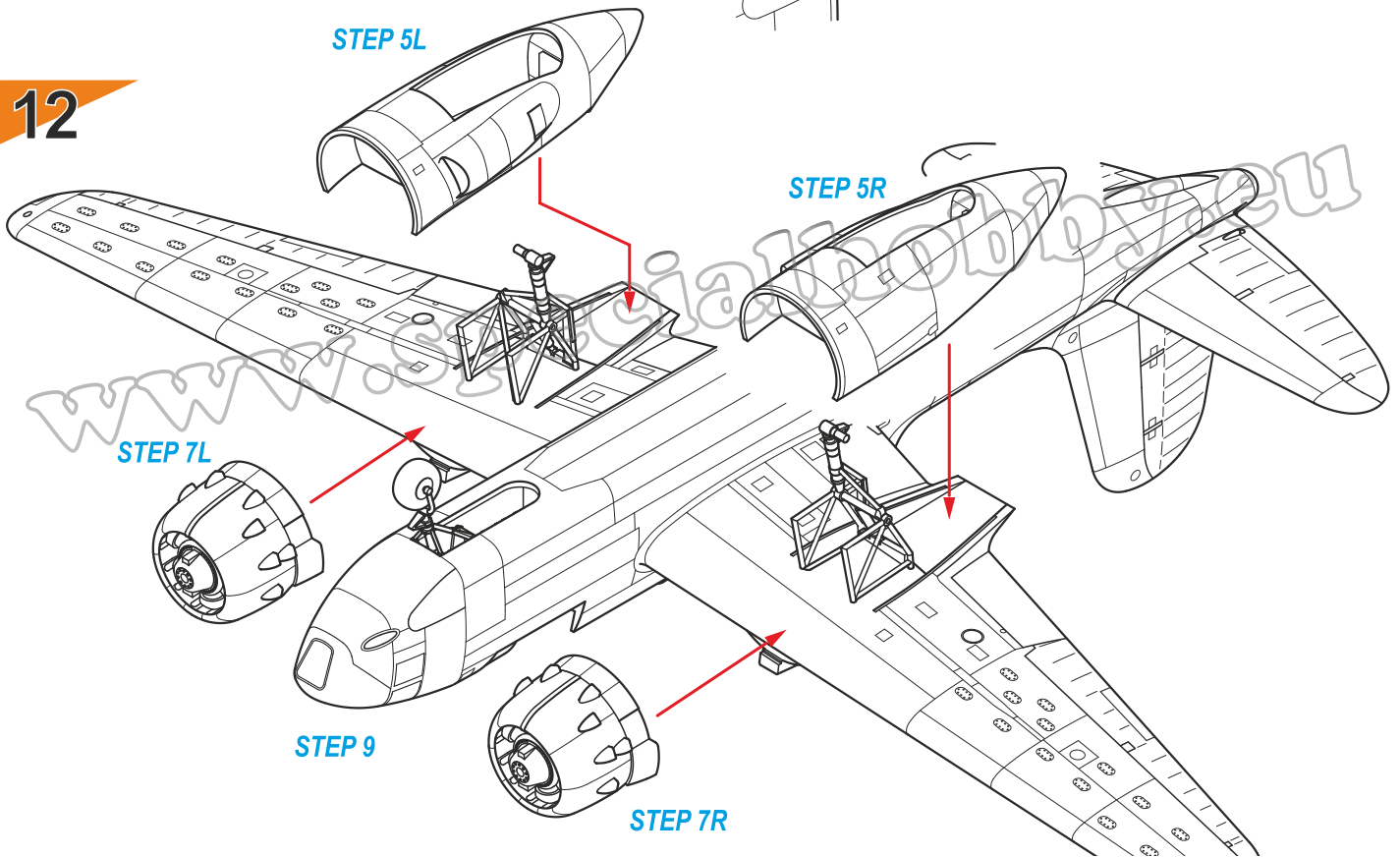

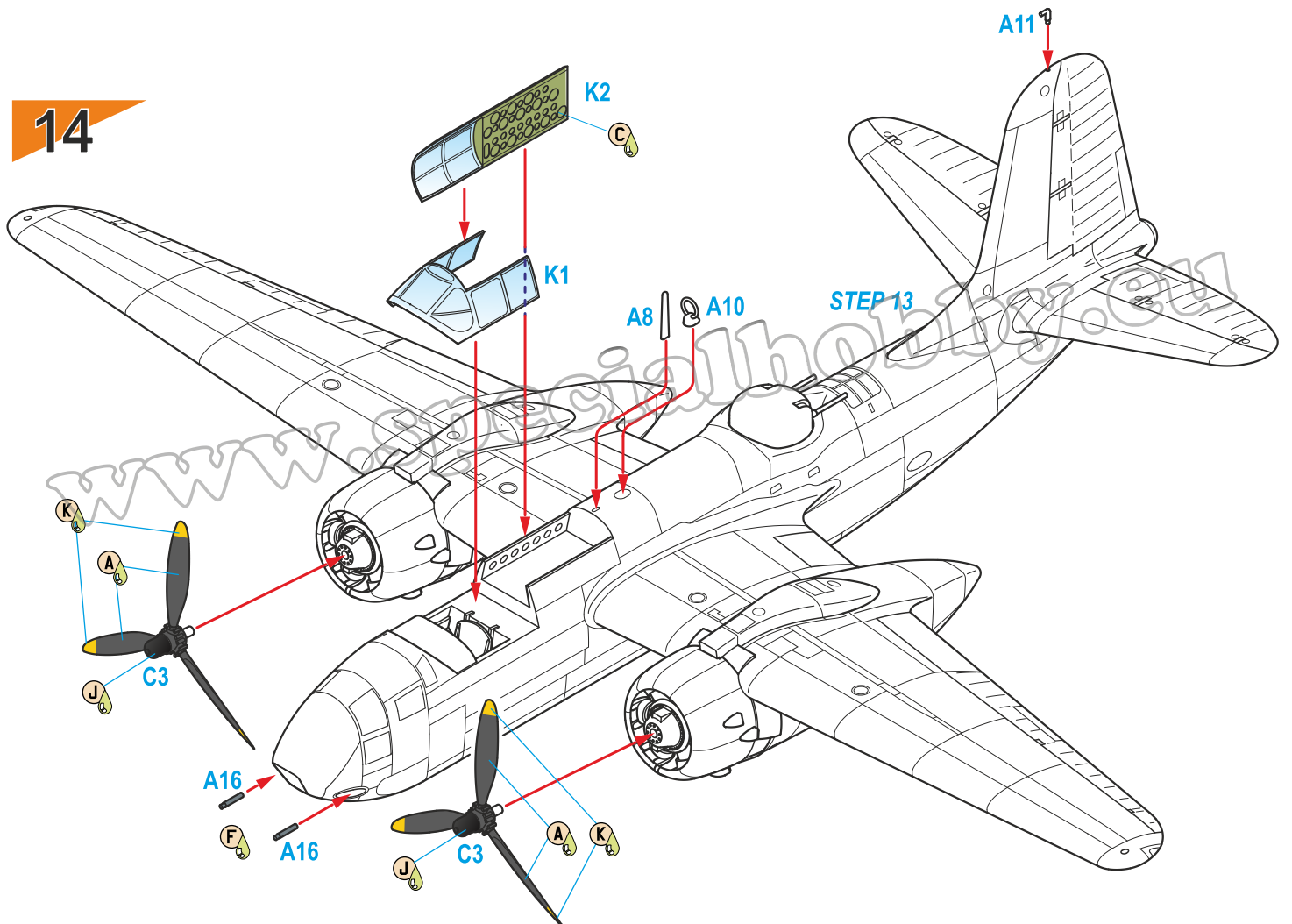
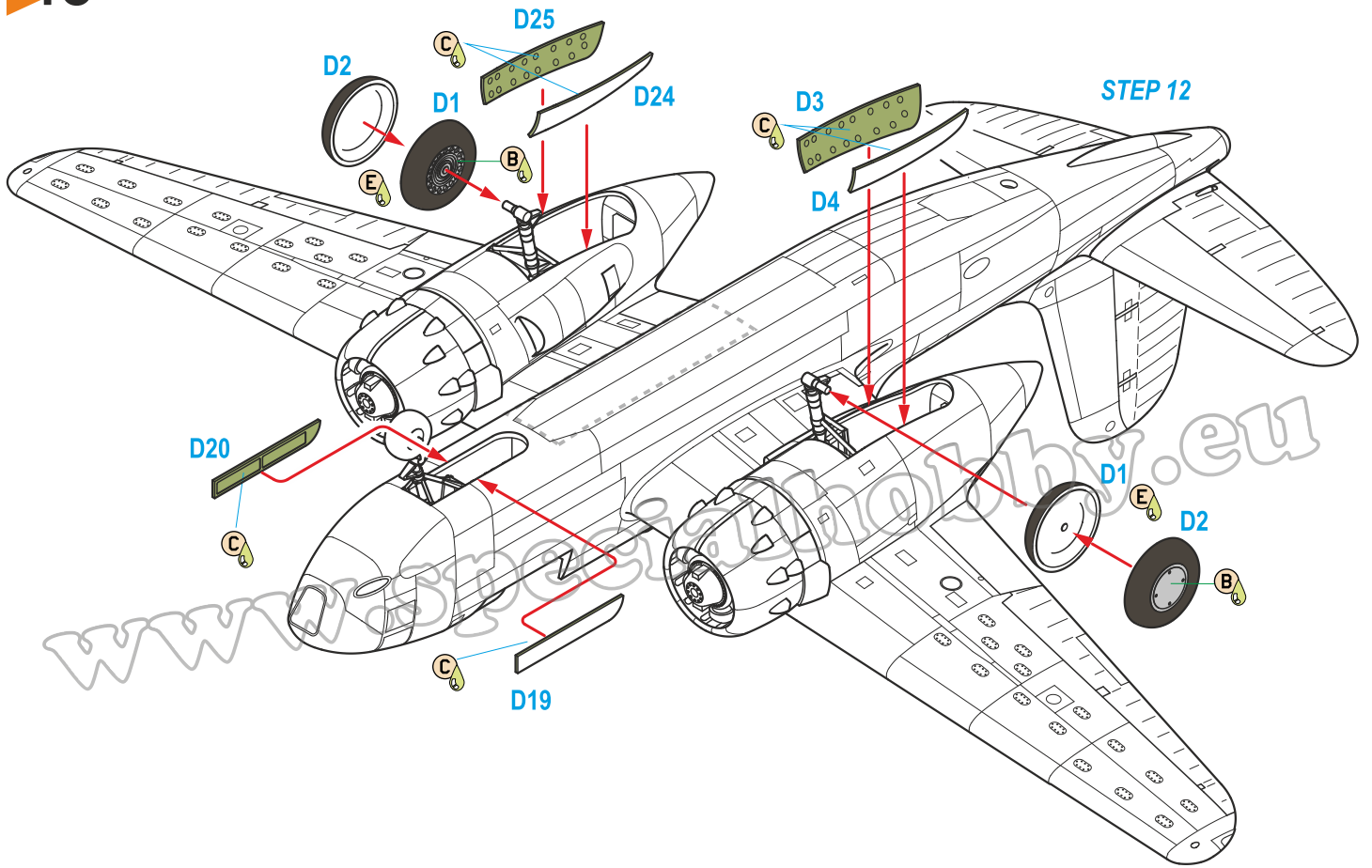



Boston Mk.IV, BZ453/OA-B, 342nd Squadron (Free French) Lorraine, RAF 137th Wing, B-50 airbase (Vitry-le-Francois), France, October 1944. It is not sure whether this machine had the serial number painted on.

Boston Mk.IV, BZ453/OA-B, 342. sq.(Free French) Lorraine, 137. wing RAF, základna B-50 (Vitry-le-Francois), Francie, říjen 1944. Není jisté, zda měl tento stroj nesl sériové číslo.

**CAM. A**

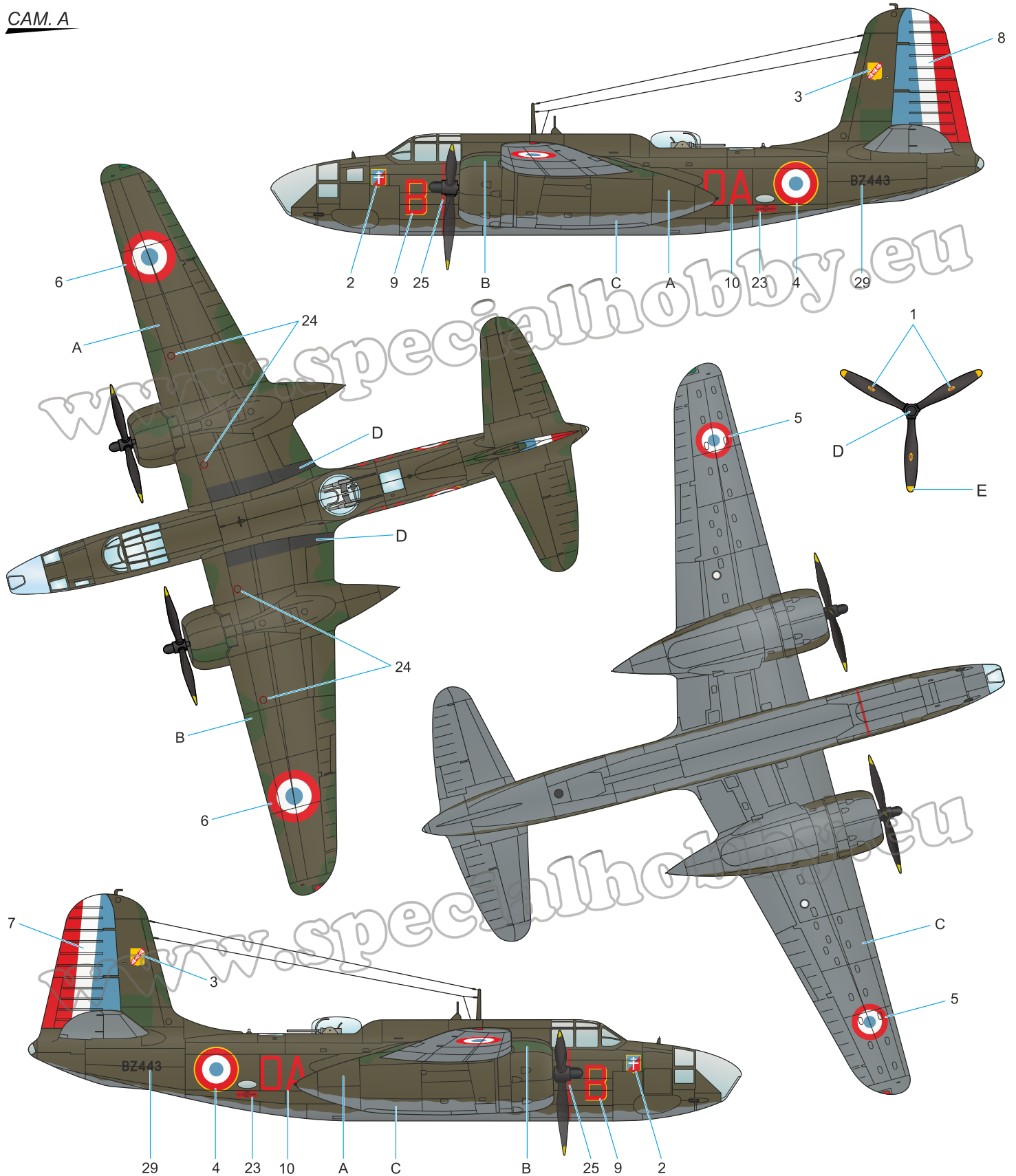

- |   |   |   |  |   |  |
|---|---|---|--|---|--|
| <p><b>A</b></p>  <p>Olive Drab 41<br/>Nevýrazná olivová<br/>H52/C12</p> | <p><b>B</b></p>  <p>Medium Green 42<br/>Středně zelená<br/>H302/C302</p> | <p><b>C</b></p>  <p>Neutral Gray 43<br/>Neutrální šedá<br/>H53/C13</p> | <p><b>D</b></p>  <p>Flat Black<br/>Matná černá<br/>H12/C33</p> | <p><b>E</b></p>  <p>Žlutá<br/>Yellow<br/>H4/C4</p> | <p><b>special</b><br/><b>HOBBY</b></p>  |
|---|---|---|--|---|--|

Boston Mk.IV, BZ507/Y, pilot F/Sgt. John Samain, RAF  
18th Squadron, Italy, 1944–45. The aircraft sported markings  
of 105 flown missions on the nose.

Boston Mk.IV, BZ507/Y, 18. sq. RAF, letoun pilotovaný F/Sgt.  
Johnem Samainem má na přídí symboly odlétaných sto pět  
misí, Itálie, přelom let 1944–45.

**CAM. B**

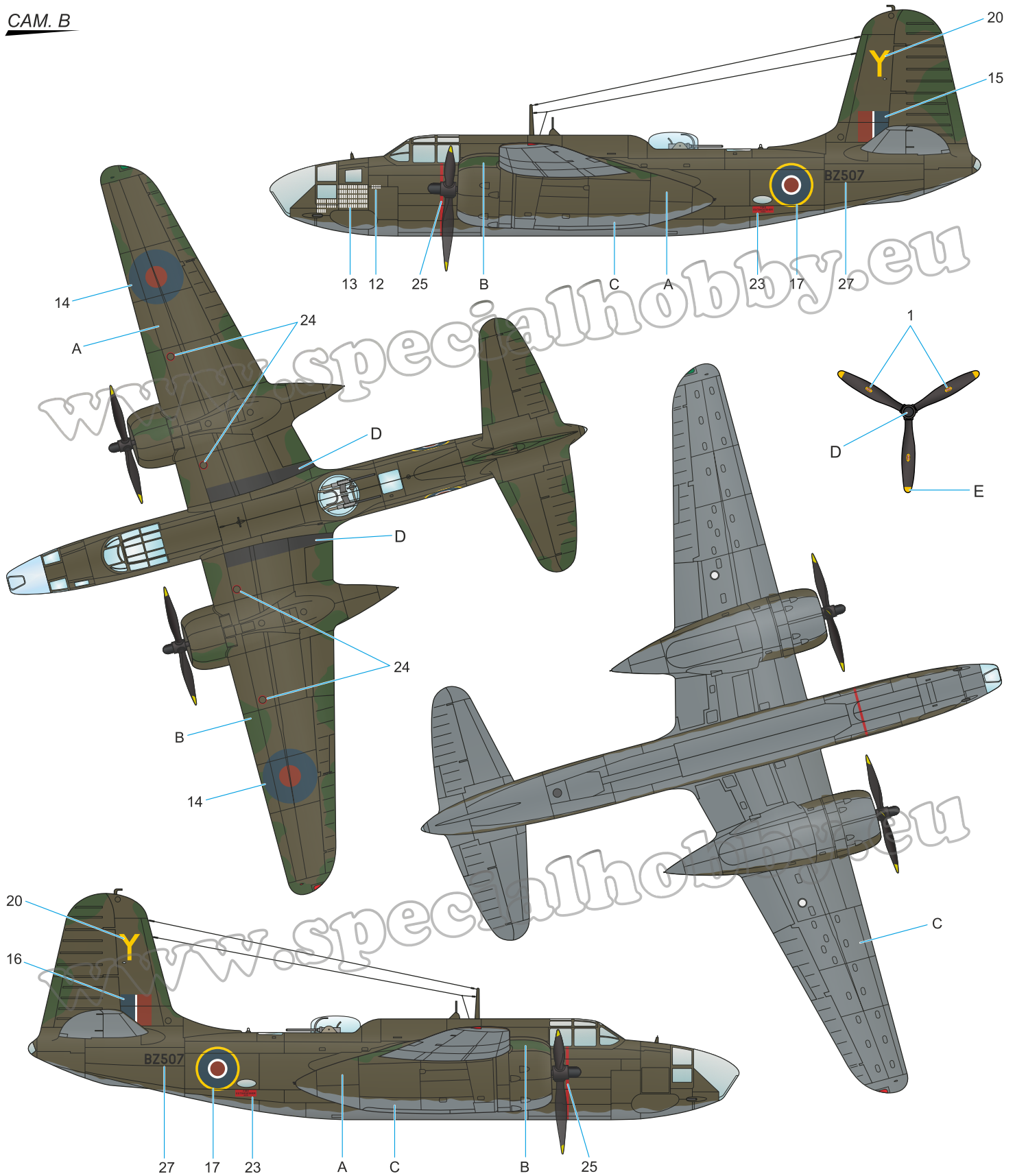

- |  |   |   |  |   |
|--|---|---|--|---|
|  |  |  |  |  |
| <p><b>A</b> Olive Drab 41<br/>Nevýrazná olivová<br/>H52/C12</p>                    | <p><b>B</b> Medium Green 42<br/>Středně zelená<br/>H302/C302</p>                    | <p><b>C</b> Neutral Gray 43<br/>Neutrální šedá<br/>H53/C13</p>                      | <p><b>D</b> Flat Black<br/>Matná černá<br/>H12/C33</p>                               | <p><b>E</b> Žlutá<br/>Yellow<br/>H4/C4</p>  |



Boston Mk.V, BZ611/Z, RAF 13th Squadron, Italy 1945.  
 Note the repaired paint on the right side of the nose.

Boston Mk.V, BZ611/Z, 13. sq. RAF, Itálie 1945.  
 Povšimněte si opravené barvy na pravé straně přídě.

**CAM. C**

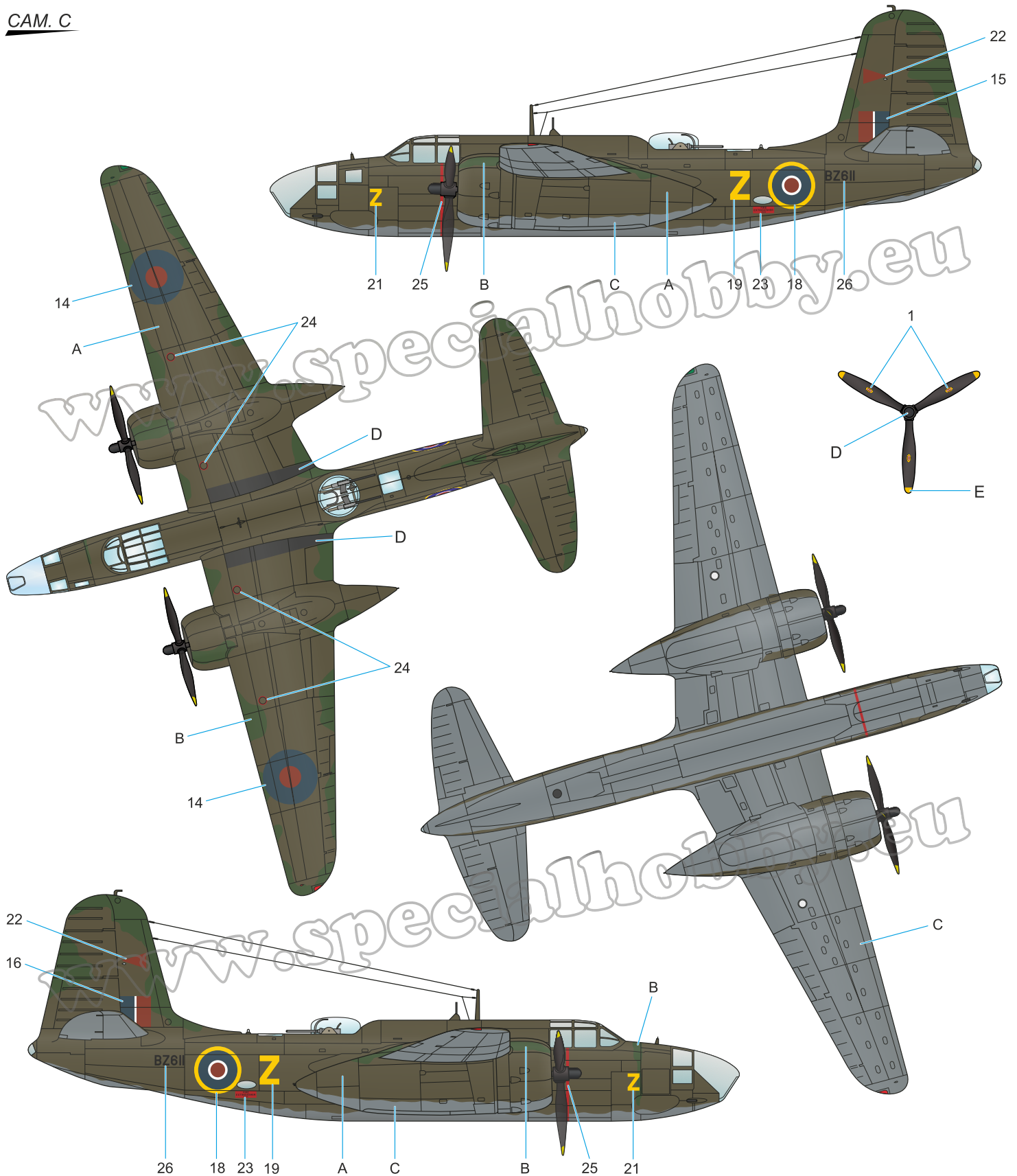

- |  |   |   |  |   |  |  |  |   |  |  |
|--|---|---|--|---|--|--|--|---|--|--|
|  | <p><b>A</b> Olive Drab 41<br/>Nevýrazná olivová<br/>H52/C12</p> |  | <p><b>B</b> Medium Green 42<br/>Středně zelená<br/>H302/C302</p> |  | <p><b>C</b> Neutral Gray 43<br/>Neutrální šedá<br/>H53/C13</p> |  | <p><b>D</b> Flat Black<br/>Matná černá<br/>H12/C33</p> |  | <p><b>E</b> Žlutá<br/>Yellow<br/>H4/C4</p> | <br> |
|--|---|---|--|---|--|--|--|---|--|--|

CAM. D

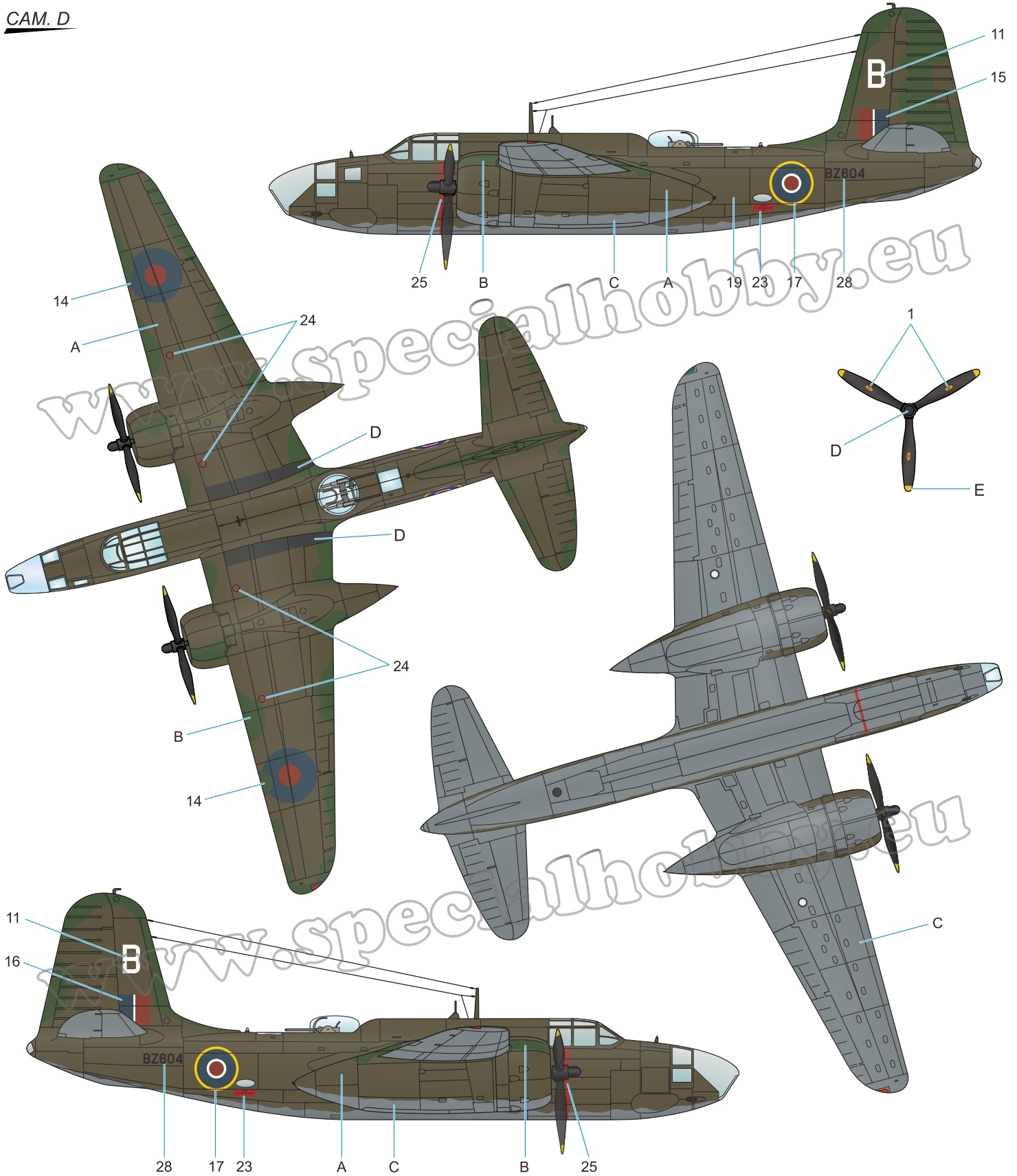

- A**

Olive Drab 41  
Nevýrazná olivová  
H52/C12
- B**

Medium Green 42  
Středně zelená  
H302/C302
- C**

Neutral Gray 43  
Neutrální šedá  
H53/C13
- D**

Flat Black  
Matná černá  
H12/C33
- E**

Žlutá  
Yellow  
H4/C4

