

B-29A SUPERFORTRESS

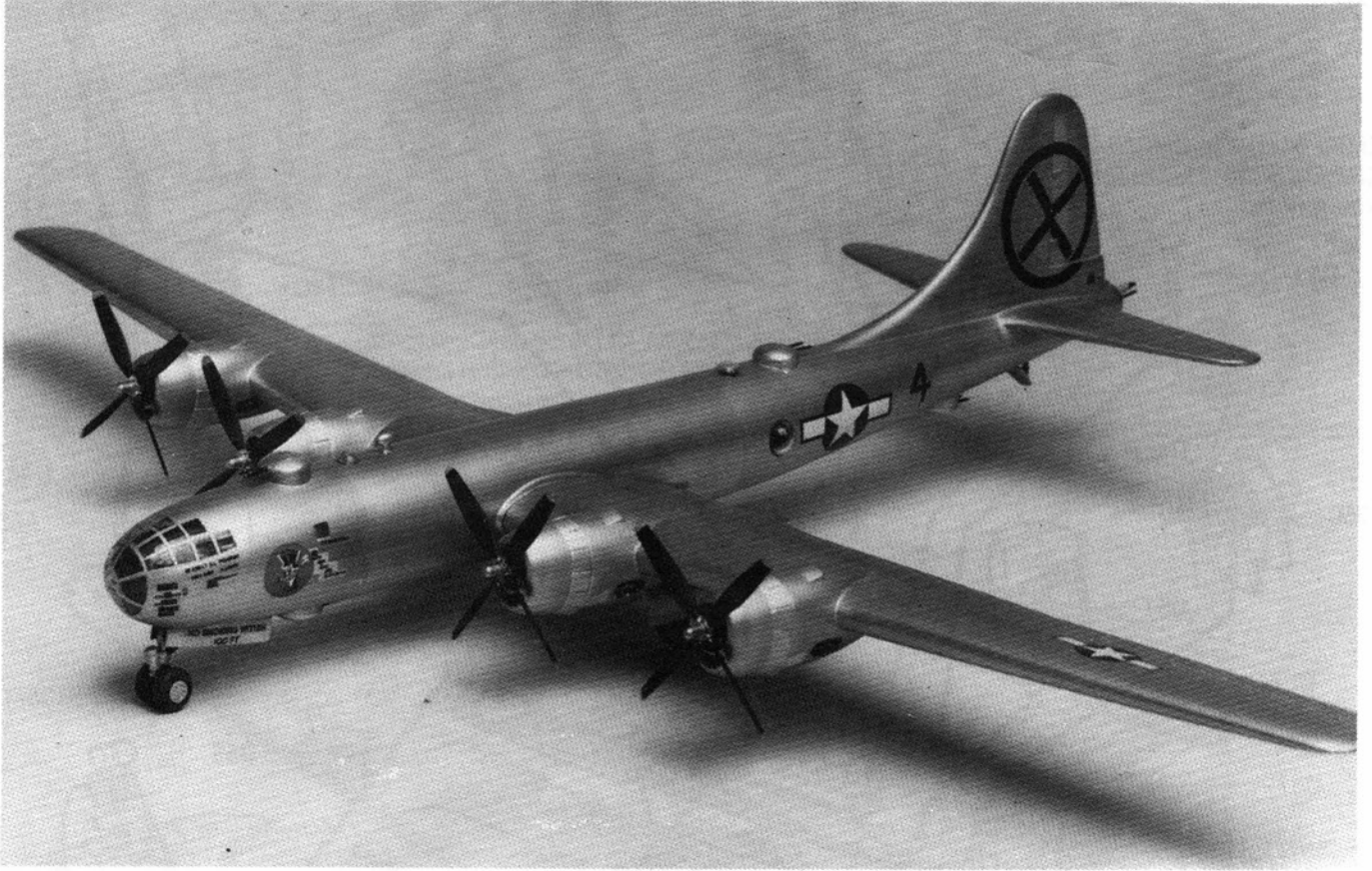

1:72 Scale

ACADEMY

HOBBY MODEL KITS

“B-29’S RAID TOKYO” To many people, these headlines were the first announcement that America actually possessed the long dreamed of “superbomber”. And super it was, by all comparative standards. It’s four Wright R-3350-23 eighteen cylinder Cyclone engines each gave 2,430 horsepower for war emergency and 8,198 gallons of fuel enabled it to carry up to 20,000 pounds of bombs 3,250 miles and return. The B-29 had a range greater than any other bomber of its day. With a pressurized fuselage and two superchargers on each engine, the new ship had a service ceiling of 31,850 feet. The Superfortress, whose name was adapted from it’s smaller brother, the B-17, was also the heaviest in the skies, having an empty weight of 70,140 pounds and a gross of 110,000 pounds; and a top speed of 358 mph made it one of the fastest.

The fire control system of the B-29 was the most advanced yet. Four gun turrets with twin 50 cal. machine guns were remotely controlled from within the fuselage. Forward protection was afforded by the upper and lower positions just behind the cockpit. A manned tail position offered the bite of a 20 mm cannon in addition to the twin 50’s to anyone venturing to close.

The B-29A had a wing span of 142 feet, 3 inches with a wing area of 1,736 square feet. The length of the aircraft was 99 feet and height was 29 feet 7 inches. There were a total of 1,116 B-29A’s built by Boeing.

The markings included in this kit depict The Big Time Operator, 42-24791, of the 9th Bomb Group. This airplane flew a total of 48 bombing and mining missions overseas, an impressive record.

1

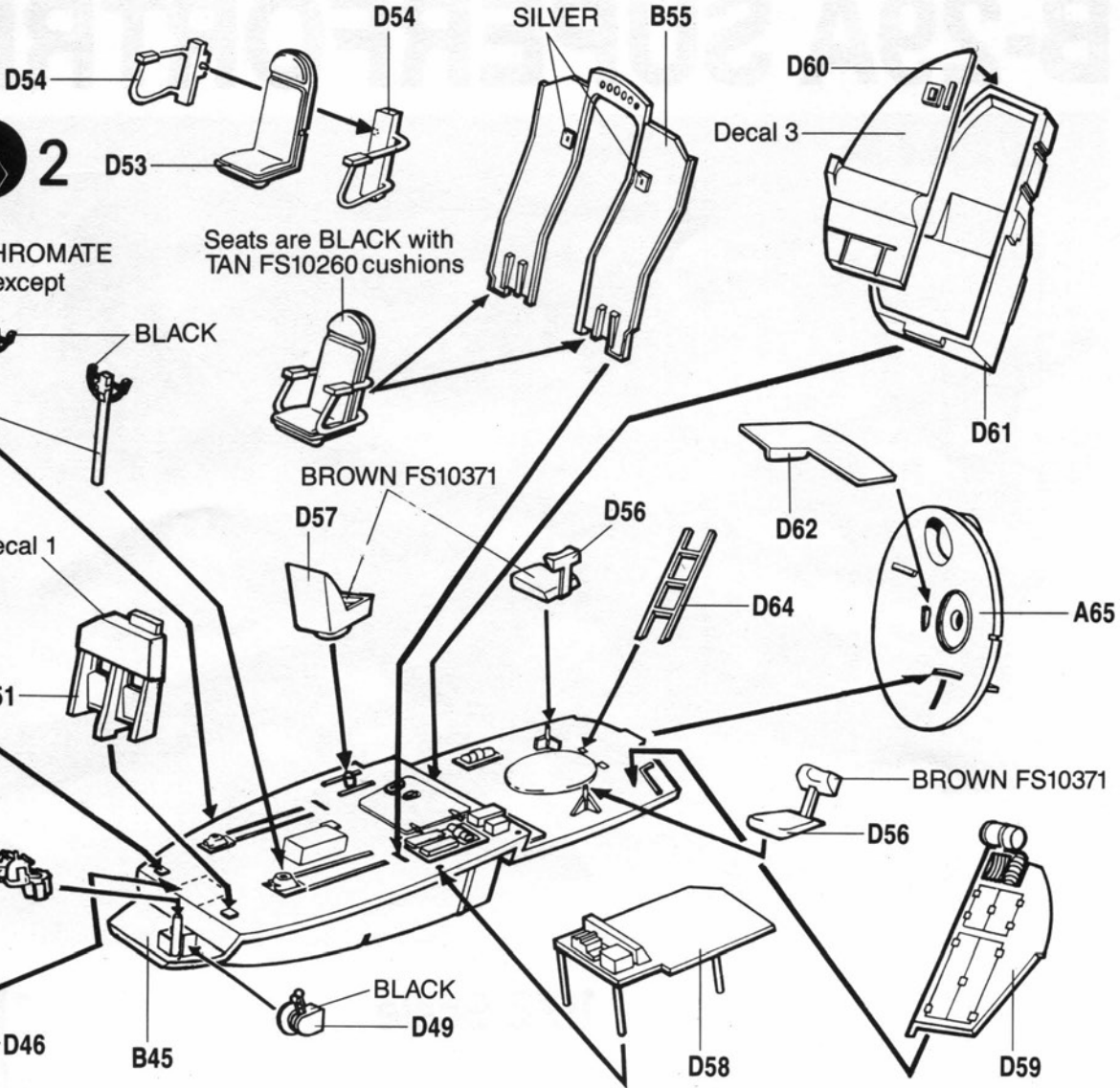

2

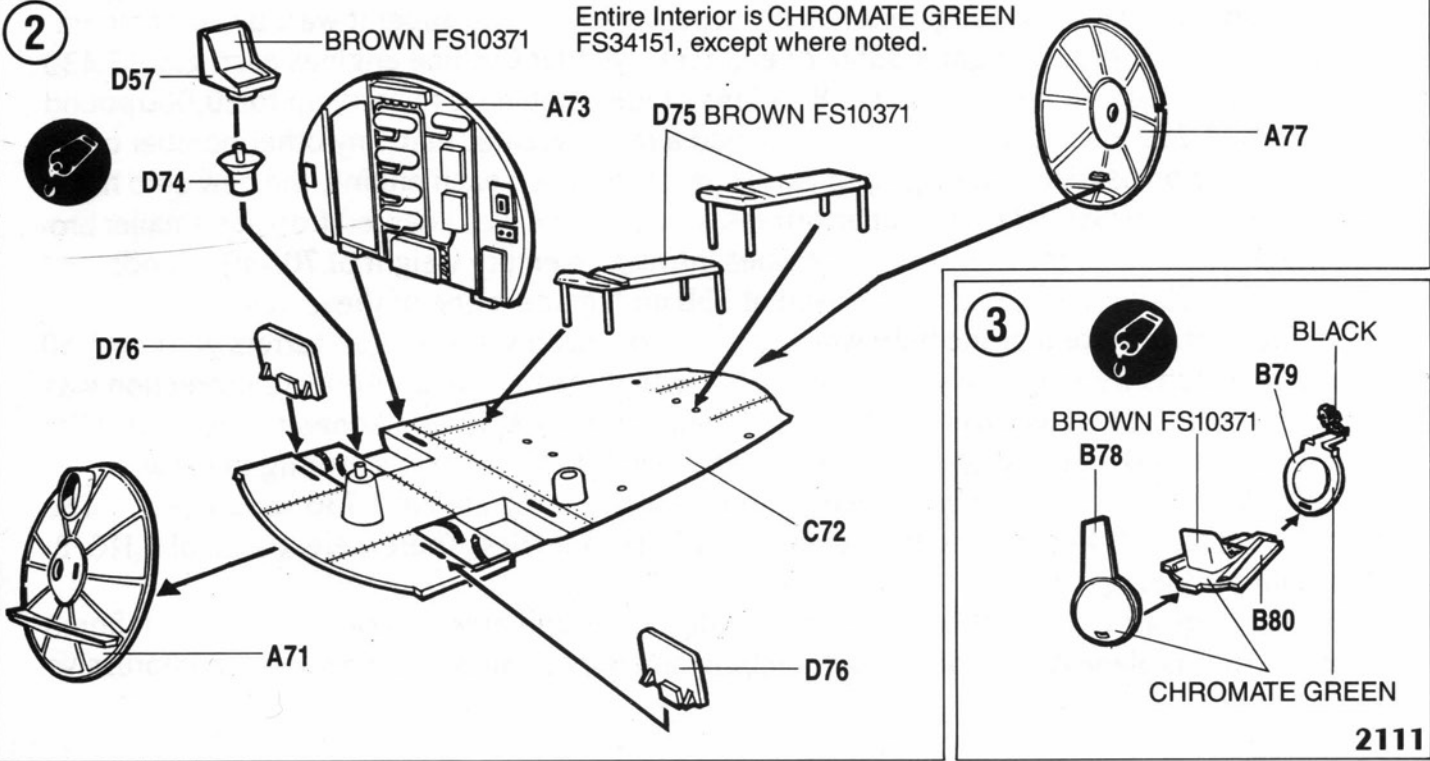

3

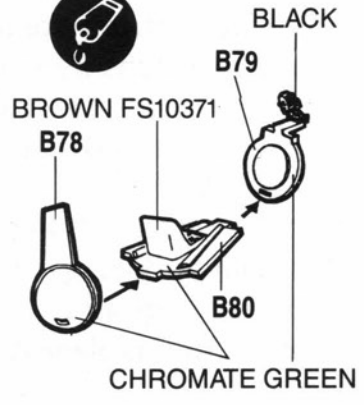

4



Entire Interior is CHROMATE GREEN FS34151, except where noted.

Notice

Make two holes before
Assembling the fuselage halves.

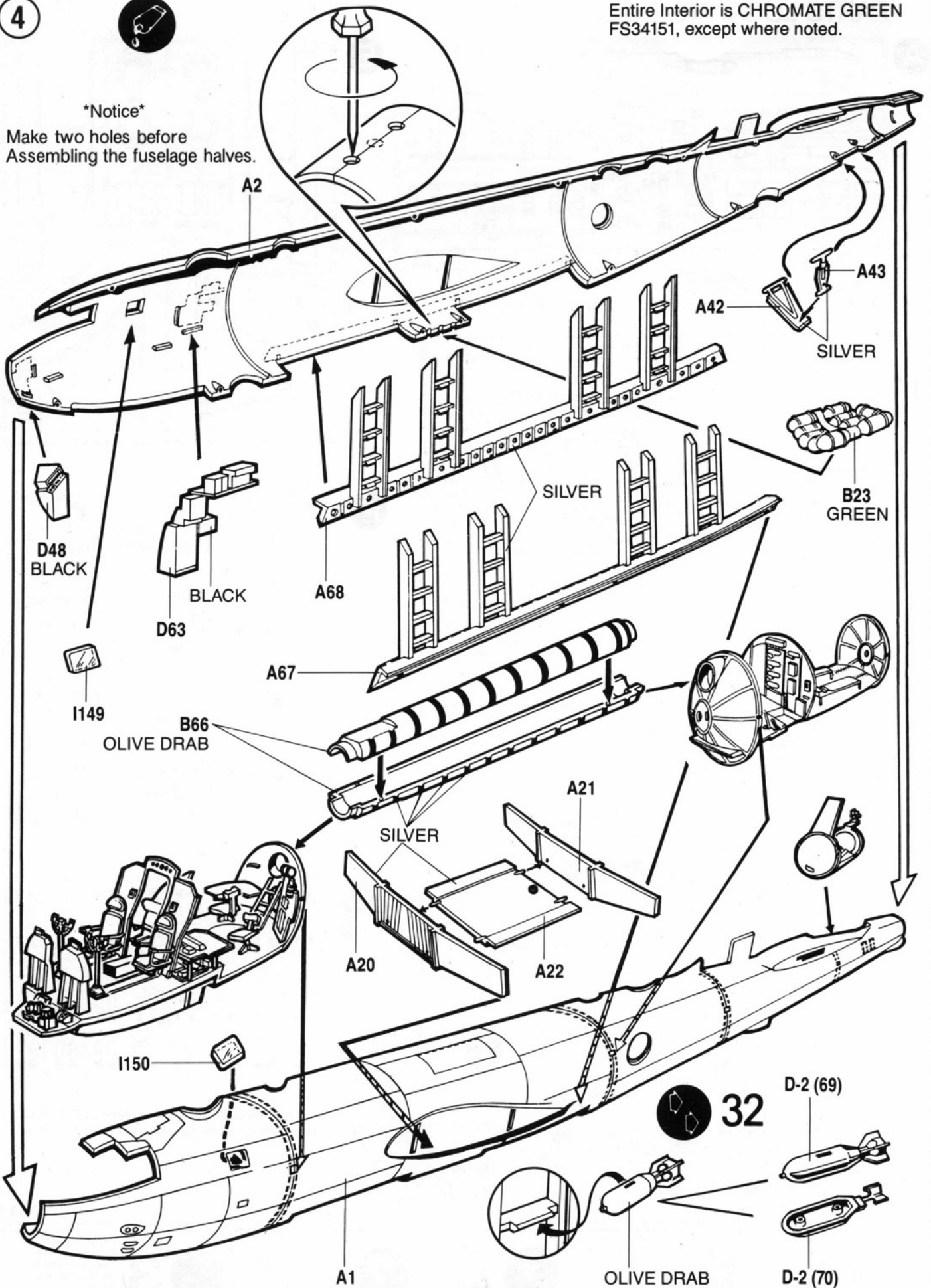

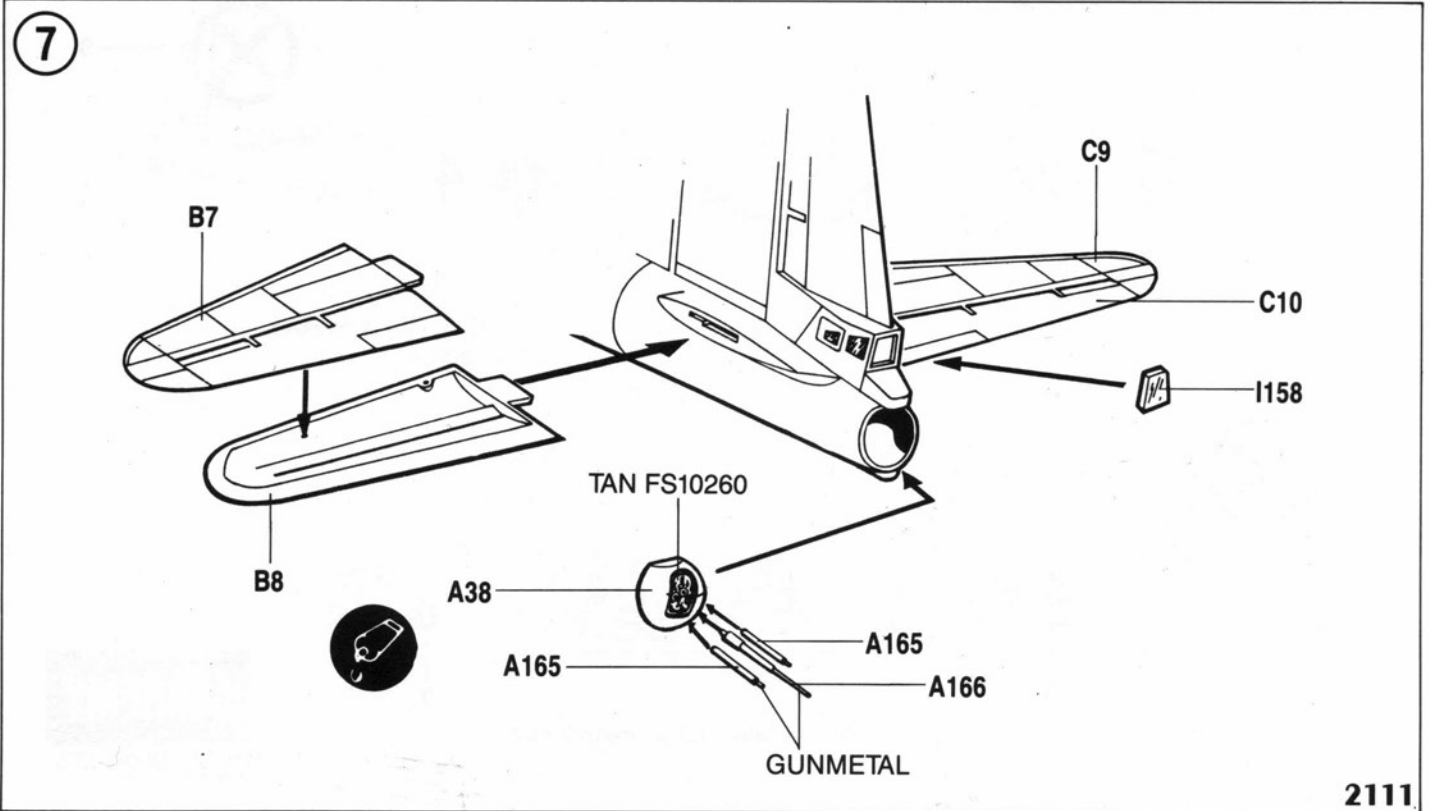
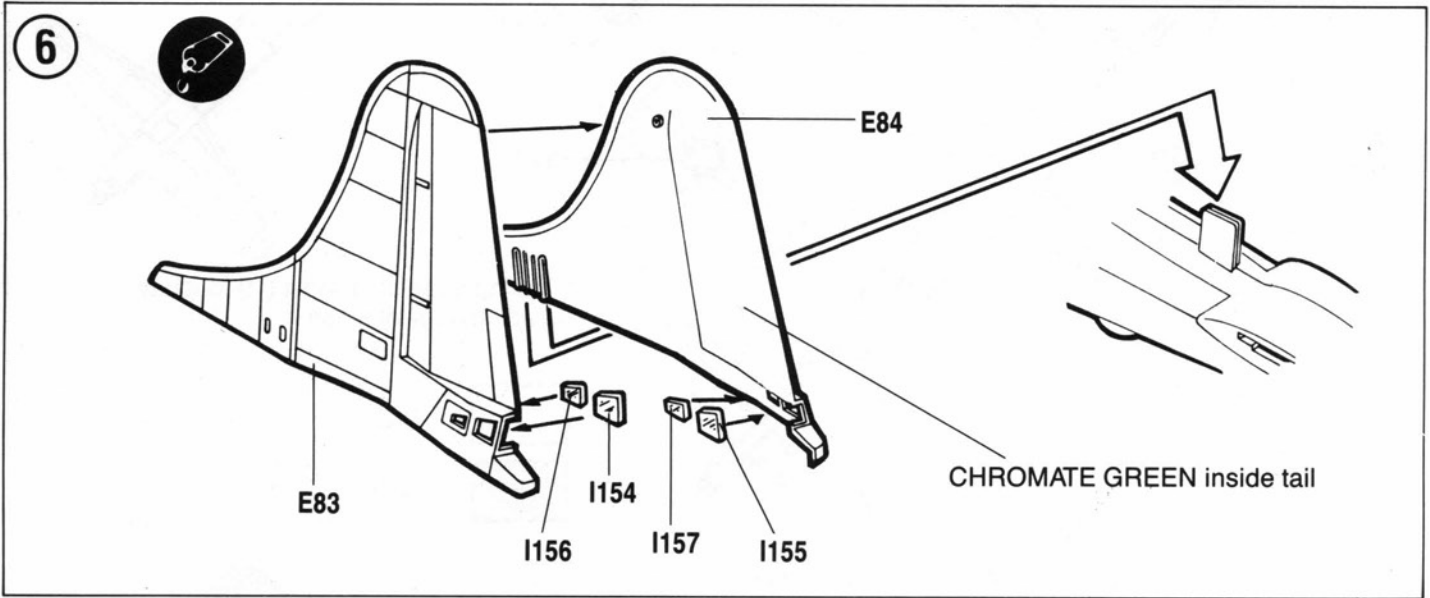
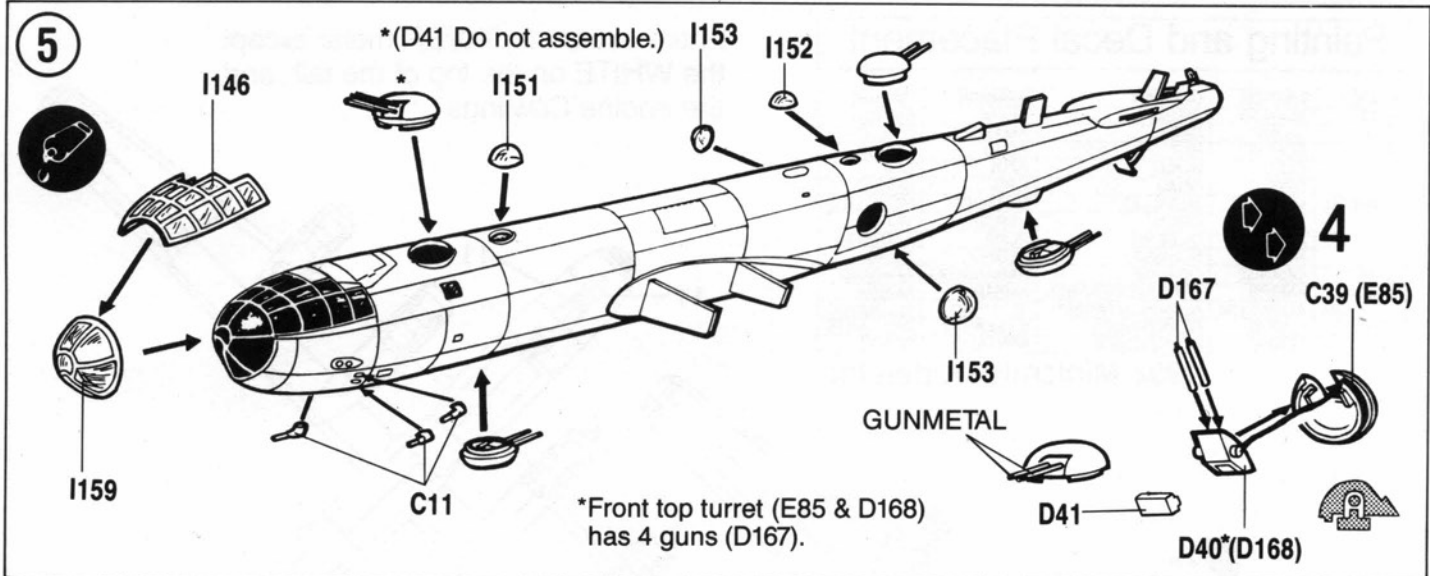

8



2

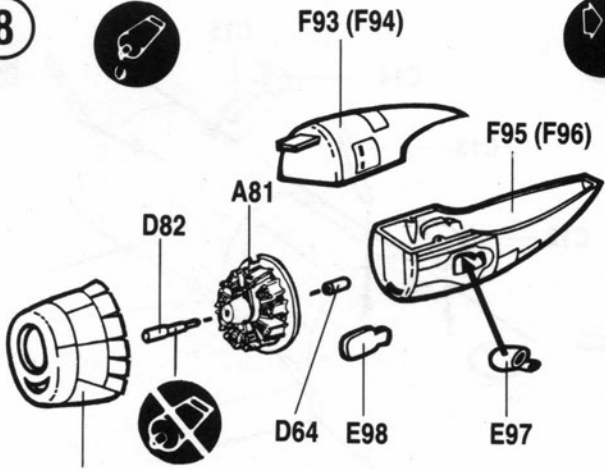

E88
OUTBOARD

Engine: Cylinders a BLACK, Case is GRAY,
firewall is CHROMATE GREEN FS3515 and
the superchargers a weathered RUST

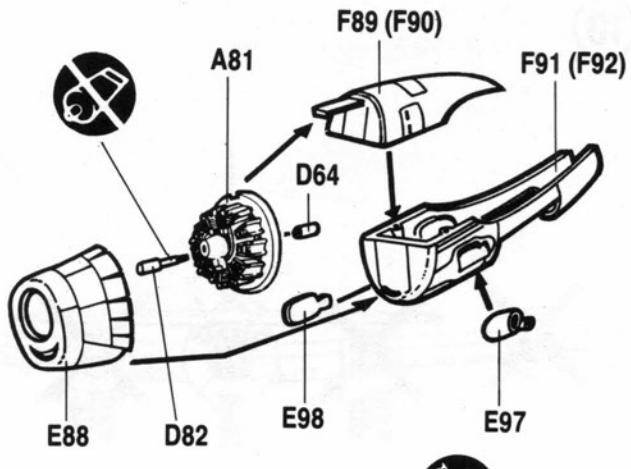

E88
INBOARD



2

9



2

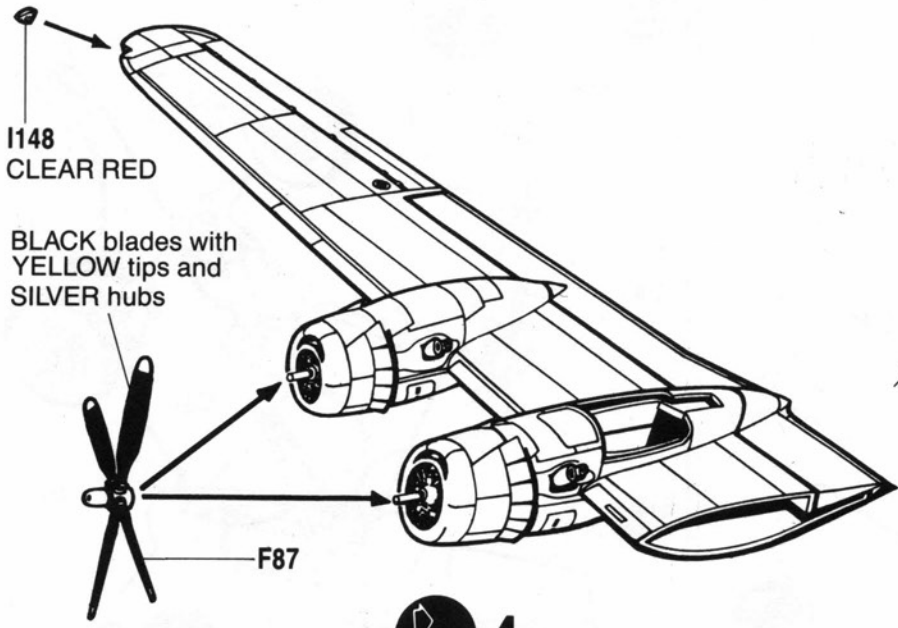
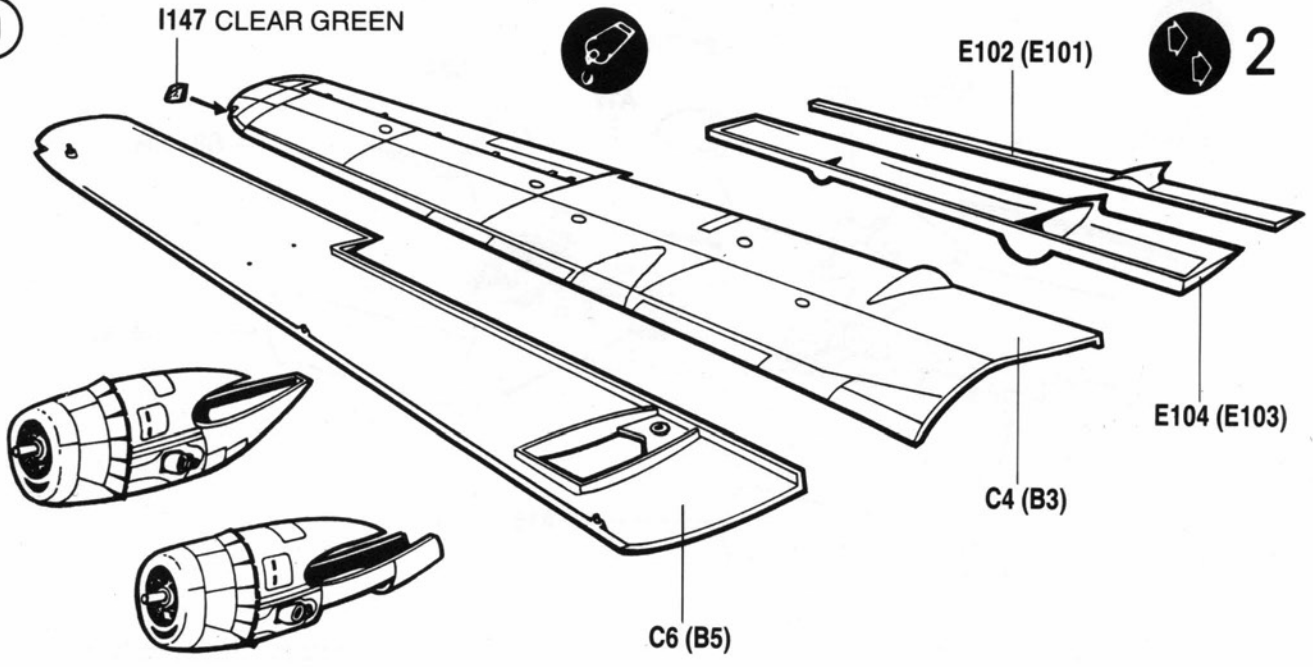

4

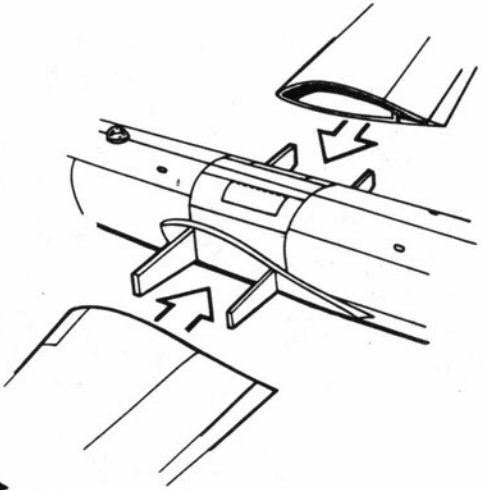

10

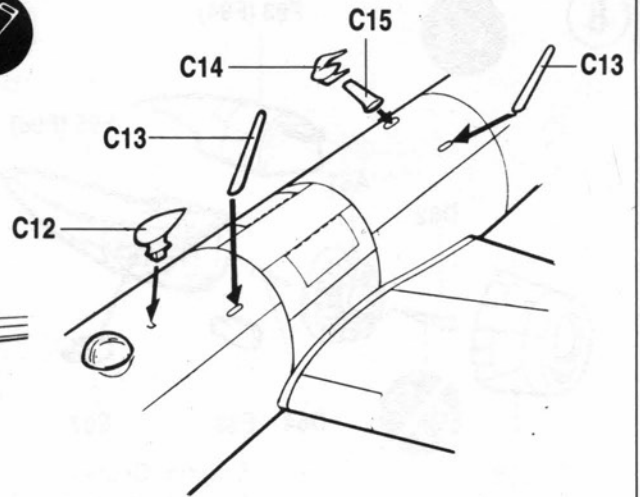
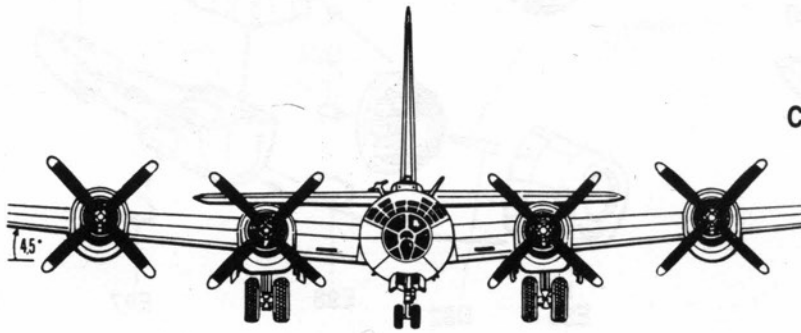

11

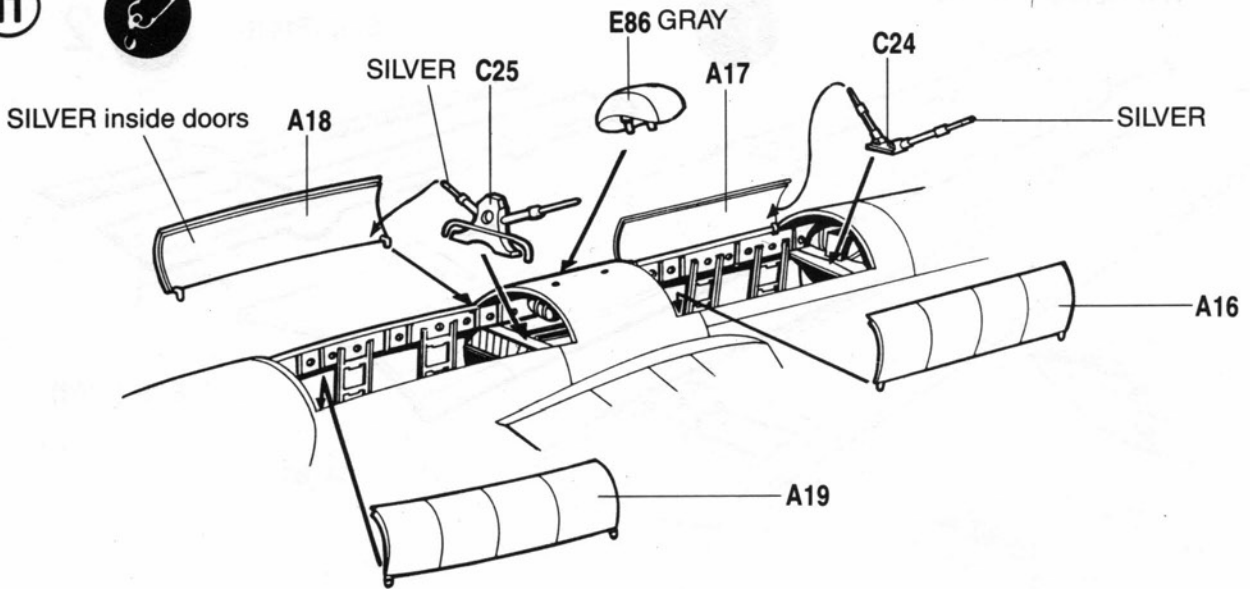

12

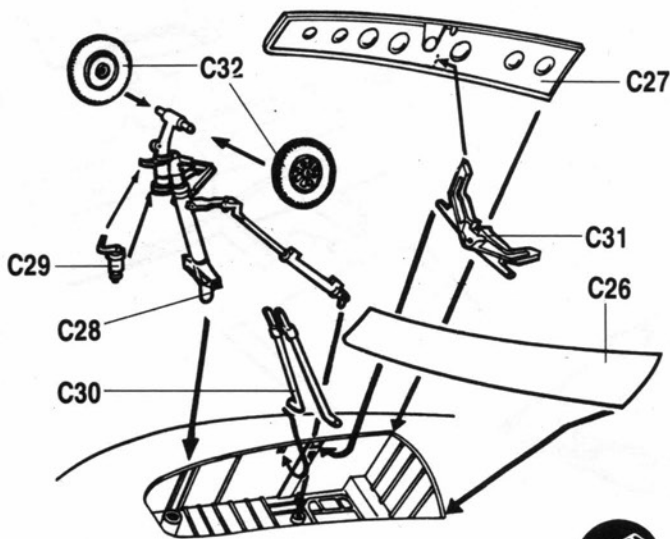

SILVER Struts, wheels and inside doors and wheel wells. Tires are BLACK.



13

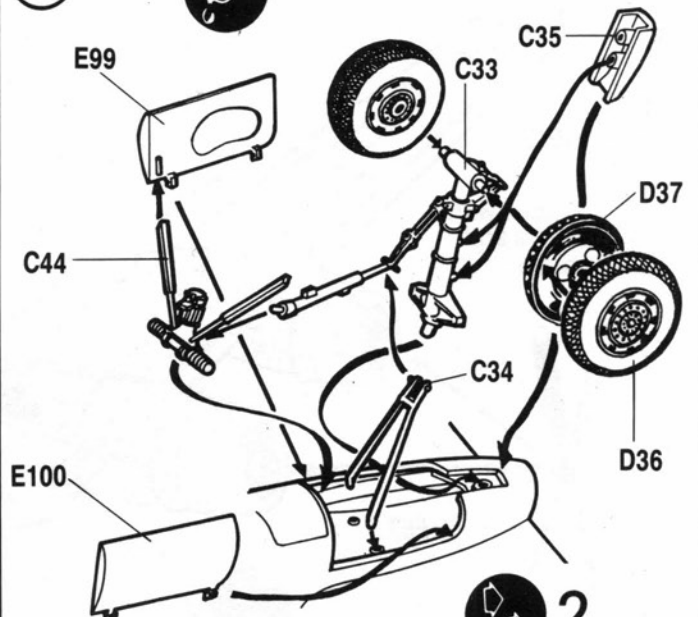

2

2111

Painting and Decal Placement

ENGLISH	FRENCH	GERMAN	SPANISH	ITALIAN
WHITE	BLANCO	WEISS	BLANC	BIANCO
YELLOW	JAUNE	GELB	AMARILLO	GIALLO
RED	ROUGE	ROT	ROJO	ROSSO
BLUE	BLEU	BLAU	AZUL	BLU
GRAY	GRIS	GRAU	GRIS	GRIGIO
GUNMETAL	METALLIC	METALLIC	METALICO	METALLICO
GREEN	VERT	GRUN	VERDE	VERDE
SILVER	ARGENT	SILBERN	PLATA	ARGENTO
BLACK	NOIR	SCHWARZ	NEGRO	NERO
ORANGE	ORANGE	ORANGE	NARANJADO	ARANCIO
AMBER	AMBRE	BERNSTEINFARBEN	AMBAR	AMBRA
ALUMINUM	ALUMINUM	ALUMINUMFARBEN	ALUMINIO	ALLUMINIO
GLOSS	LUSTRE	GLANZENDES	BRILLANTE	BRILLANTE
FLAT	TERNE	GLANZLOSES	APAGADO	OPACO

1992 Minicraft Models Inc.

Entire aircraft is SILVER metal except the WHITE on the top of the tail and the engine Cowlings.

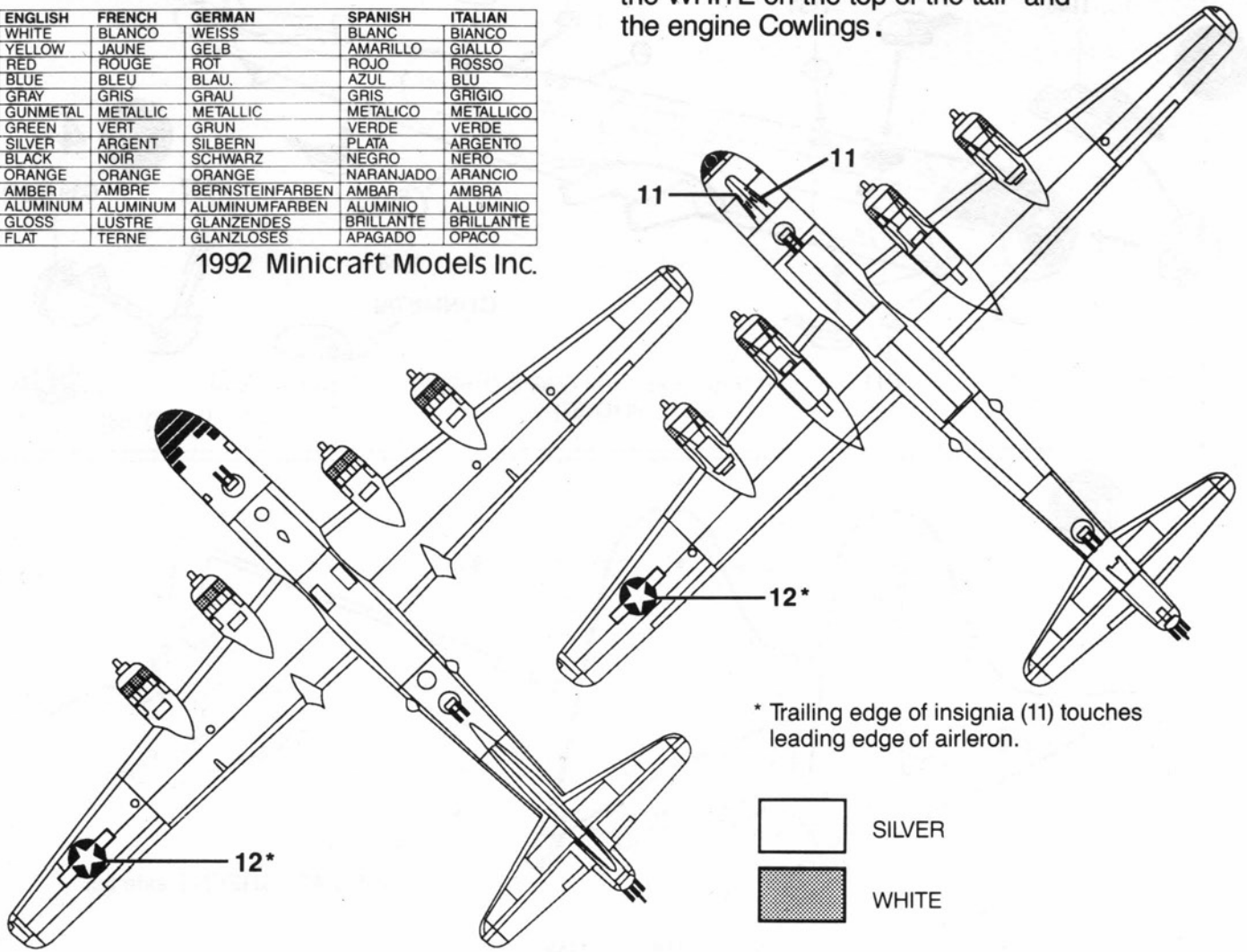

* Trailing edge of insignia (11) touches leading edge of aileron.



* Trailing edge of insignia (11) touches leading edge of aileron.

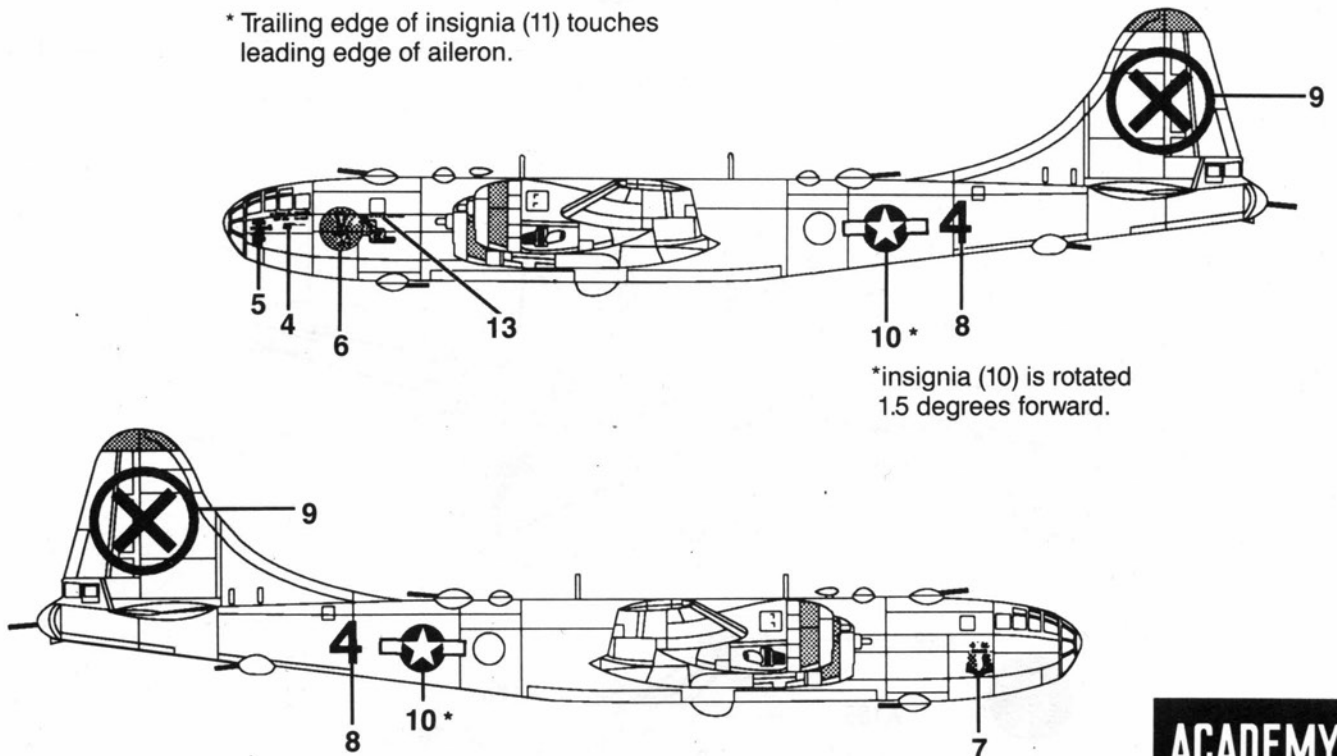

*insignia (10) is rotated 1.5 degrees forward.

* Insignia (10) is rotated 1.5 degrees forward.

PARTS LOCATING DIAGRAM

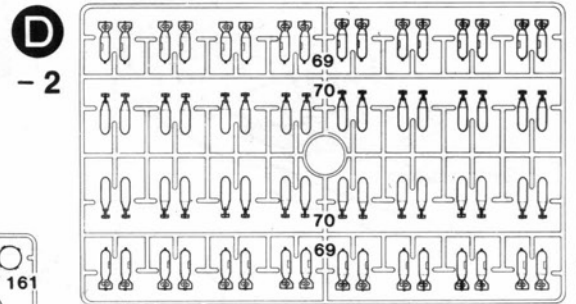
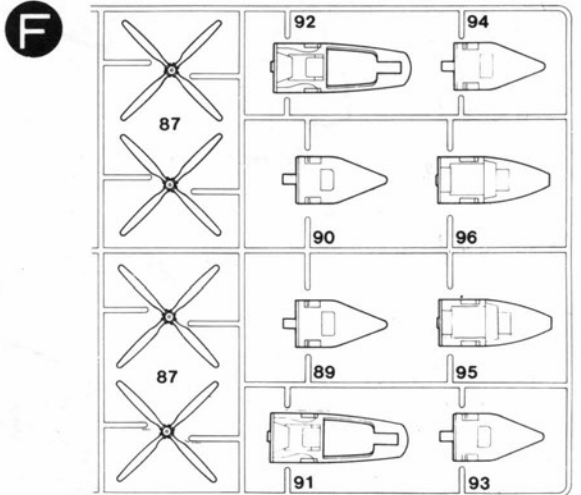
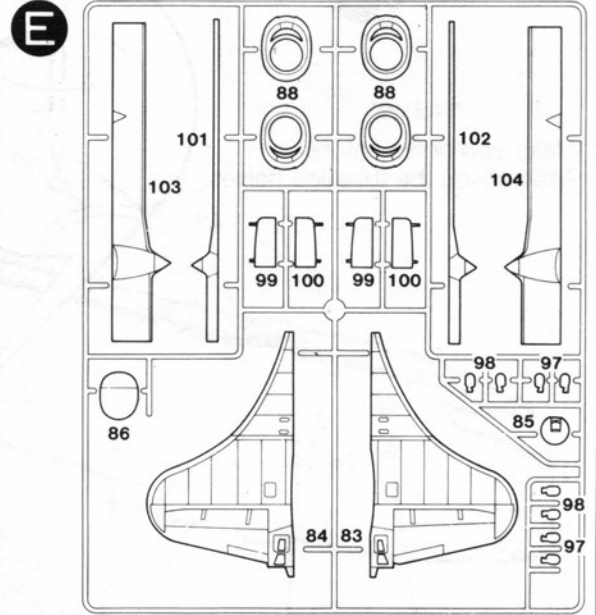
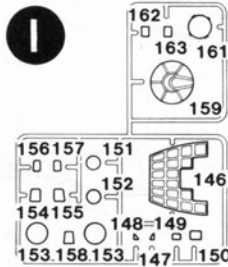
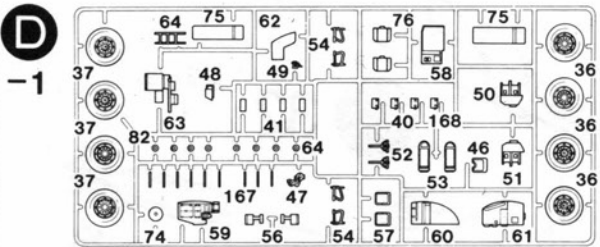
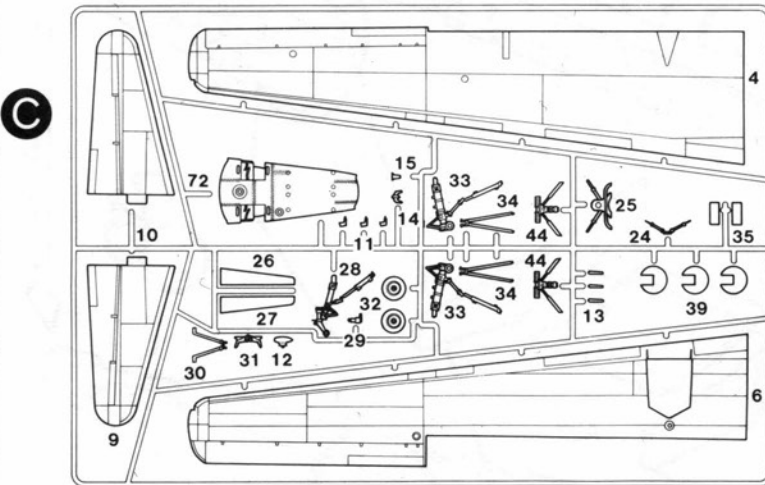
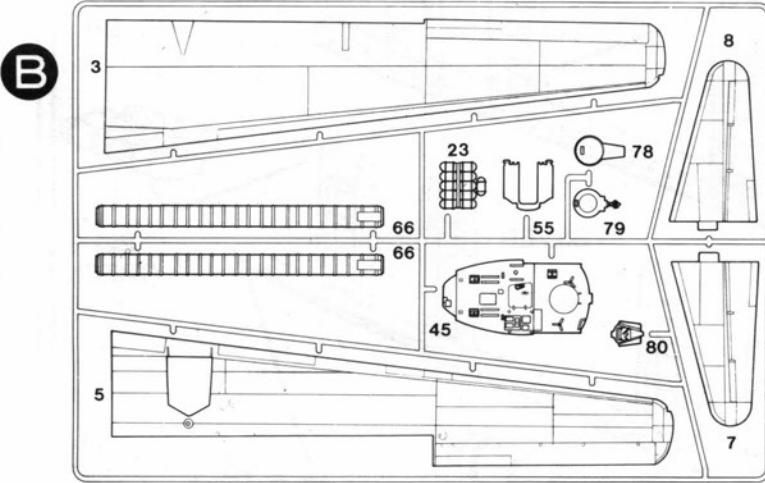
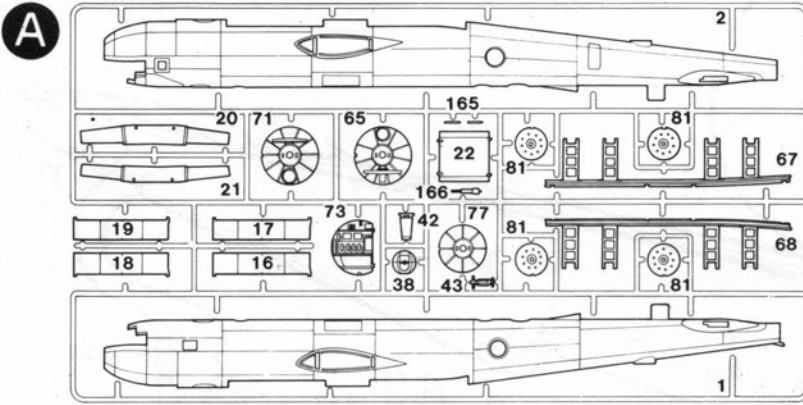

Copyright Academy Plastic Model Co., Ltd.
273-64, Suyu-dong, Kangbuk-ku, Seoul, Korea FAX: 82-2-997-3003

2111



Cement Parts
Coller
Kleben
Pegar
Incollare
Colar
Kleven



DO NOT cement
Ne pas coller
Nicht kleben
No pegar
Non incollare
Nao colar
Niet kleven



Cut away
Couper
Scheiden
Cortar
Tagliare
Cortar
Snijden



Optional parts
Choix
Auswahlmoglichkeit
Eleccion
Scelta
Opcao
Keuze



3

Repeat operation
Répéter l'opération
Vorgang wiederholen
Repitir la operacion
Ripetere
Repitir a operaçao
Herhalen