



VERLINDEN PRODUCTIONS

Ondernemersstraat, 4
B-2500 Lier/BELGIUM

CE MADE IN BELGIUM

AGE 14 AND UP/ ET PLUS

RAM II
Canadian Sherman
Conversion

1:35
792

Recommended kit: Tamiya M3 LEE (Kit N°35039) for early bogeys

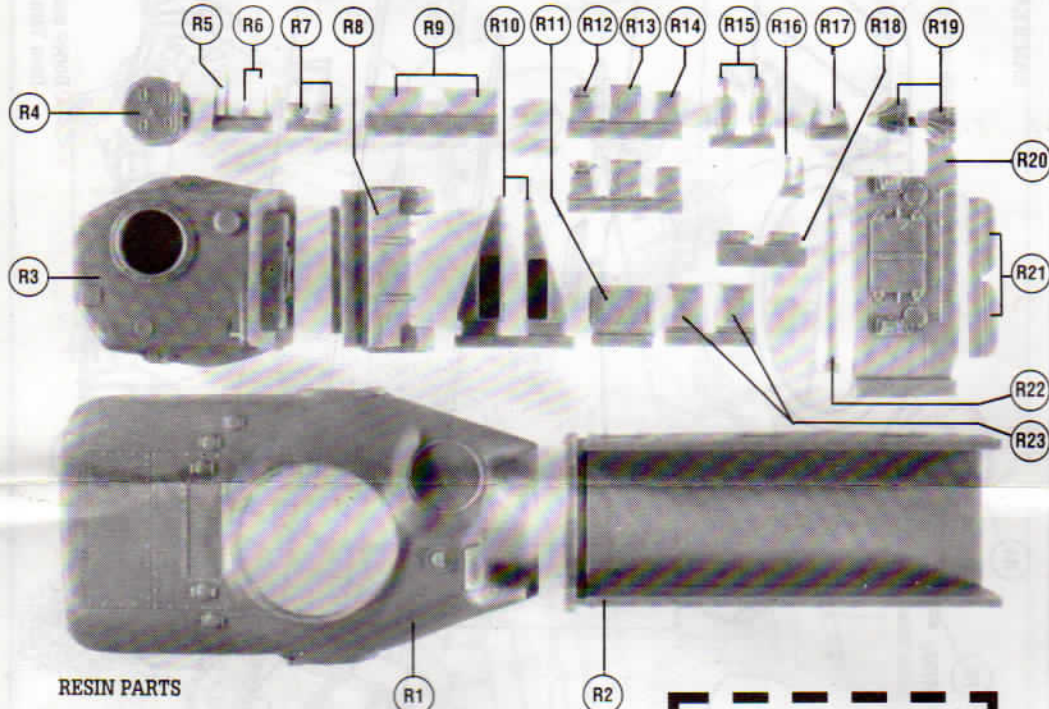

RESIN PARTS

Remove carriers with VP Razor Saw (Set 778)

PHOTO-ETCHED PARTS

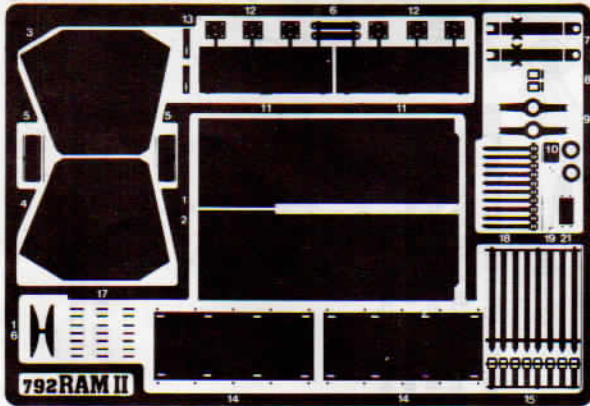

CAUTION

These photo-etched parts and resin accessories can only be glued with cyanoacrylate (Super Glue). Thoroughly clean the parts before gluing.

READ BEFORE ASSEMBLY

This instruction sheet indicates the use of the VP Update Set parts. It does not replace the instruction sheet of the plastic kit which needs to be purchased in combination with this Update Set. This sheet merely indicates the proper sequence of gluing the VP parts. When kit parts need to be cut or changed it is indicated accordingly. Every individual should determine at which stage of the assembly the VP parts are needed. It is advised to study both instruction sheets before you start assembly.

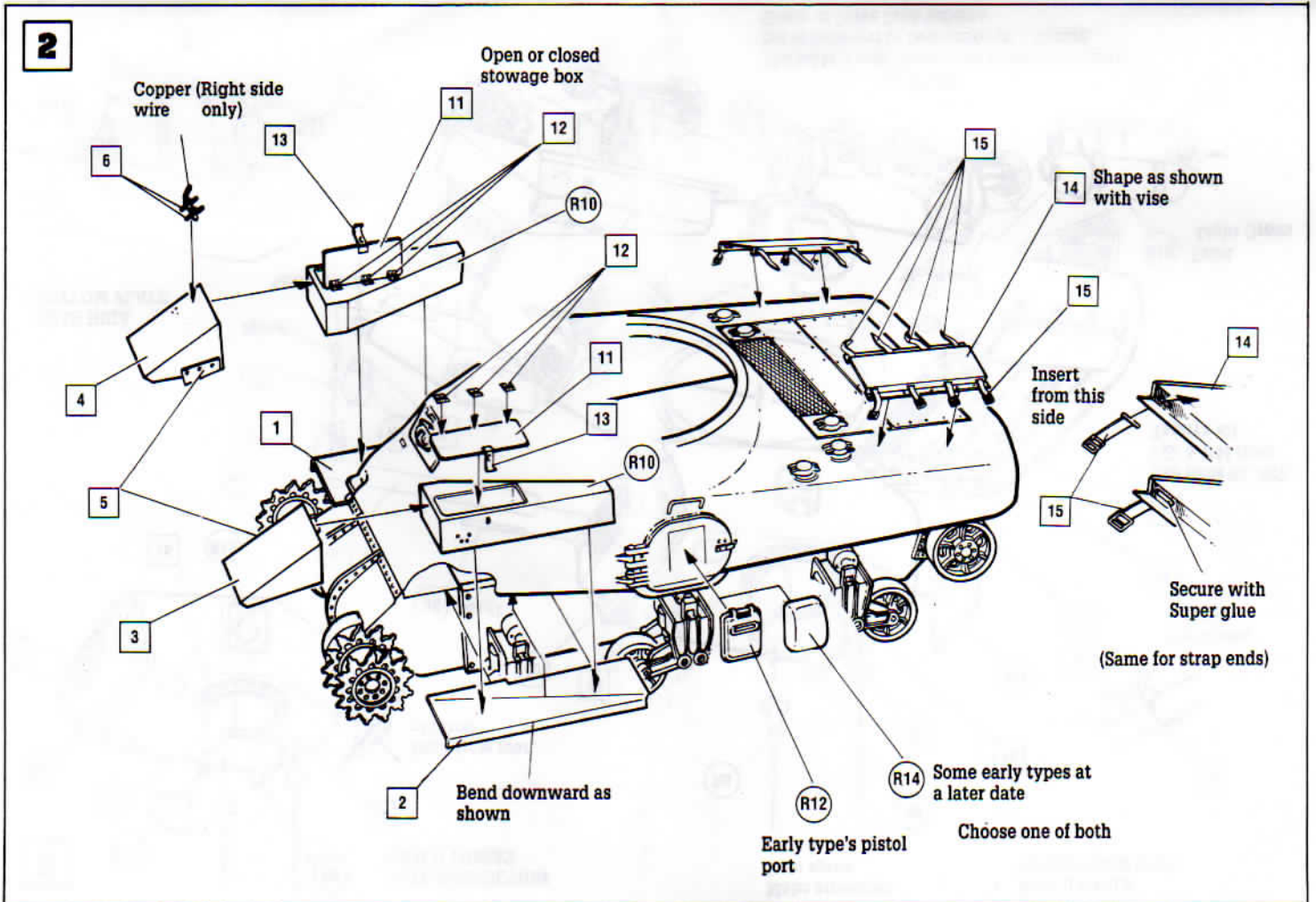
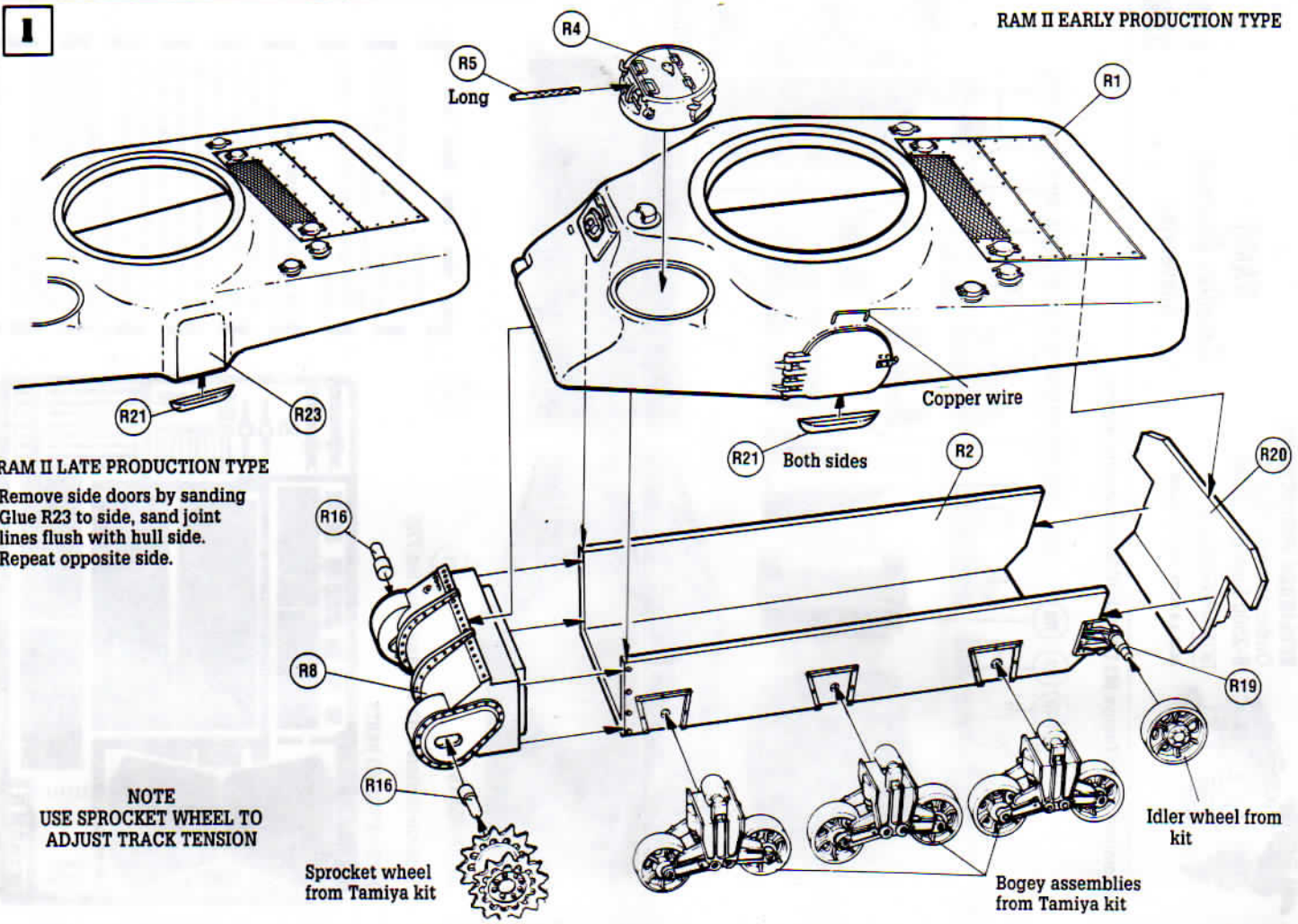

3

**LATE PRODUCTION
RAM II TURRET**

Make antennas
from sprue

**RAM II EARLY
PRODUCTION TYPE**

