



## Sd.Kfz.251/1 Ausf.D **Early~Late-mode**

### Sd.kfz.251/1 Ausf.D

Prior to WWII, the German Army was in need of a new cross-country personnel carrier to accompany tank columns for their future mobilized combat tactics. This vehicle would need to convey an infantry squadron, and possess adequate armor protection as well as firepower. After evaluating the quantitative need for this vehicle in their planned mobilized Army and the German industrial capability of that time, the German Army officials had selected the Sd.Kfz.11 3t halftrack as the basis for this project.

The Sd.Kfz.251/1 Ausf.A made its debut in 1937. It retained the chassis and engine of the original Sd.Kfz.11, with inclining armor plates added onto the chassis, with two MG34 machine guns mounted onto the armored hull. Fuel capacity was also increased from 110l. to 160l.. In order to reduce its height, the steering wheel was modified to a declining position. In addition to a crew of two, it was able to carry 10 infantrymen. Other than serving as an armored personnel carrier, the Sd.Kfz.251/1 served in diverse roles, and was produced or modified into many variants.

On the later Ausf.B and Ausf.C adapted strengthen hull structure and an armor shield for the machine gun mount. A total of 4650 Ausf.As, Bs and Cs were produced from 1937 to 1943. In 1943, the Ausf.D was introduced, which has a largely simplified hull structure in order to improve efficiency of production. Appearance of the Ausf.D was drastically different from its predecessors. Despite having a completely welded hull, the engine exhausts that were originally on both sides were moved inward beneath the armor plates. Storage boxes on both sides that were originally mounted on fenders also became integrated into the side armor plates. The aft personnel exit was enlarged and given a more declining angle, mounted machine guns were also changed from MG34s to Mg42s.

A total of 10602 of Sd.Kfz.251/1 Ausf.D were produced between 1943 and the end of the war, which was a much greater quantity than the total of Ausf.As, Bs and Cs combined. Many successful variants were also introduced, making it the backbone of late-war German mobilized units.

### Sd.kfz.251/1 Ausf.D

第二次大戦に先立ってドイツ陸軍は将来の機械化戦術のために、戦車部隊に随伴できるだけの不整地走破能力を持った新たな兵員輸送車の必要に迫られた。この車輛には、歩兵部隊を輸送する能力とともに、十分な火力と装甲を持つことが求められた。計画された機械化部隊が求める必要条件と、当時のドイツ産業の生産能力とを勘案した結果、ドイツ陸軍の当局者は、この新型兵員輸送車のベースとして、Sd.Kfz.11 3トンハーフトラックを選択したのだった。

Sd.Kfz.251/1のA型は、1937年に登場した。シャーシとエンジンはオリジナルのSd.Kfz.11のままに、傾斜した装甲板と2丁のMG34機関銃を装備し、乗員2名に加え、10名の歩兵を載せることができた。燃料搭載量は、110リットルから160リットルに増やされており、また、車高を抑えるため、操縦ハンドルは傾斜した状態で装着されていた。Sd.Kfz.251は、装甲兵員輸送車としてだけでなくさまざまな役割は傾斜した状態で装着されていた。Sd.Kfz.251は、装甲兵員輸送車としてだけでなくさまざまな役割に用いられ、多くのバリエーションタイプが製造された。

その後のB型とC型では、装甲が強化されるとともに、機関銃に防盾が追加された。1937年から1943年の間に、A型、B型、C型あわせて4650輛が生産された。そして生産効率を上げるために、車体の構造を大幅に単純化したD型が1943年に登場する。D型の外見は、それ以前のタイプとは大きく異なるものとなった。完全溶接車体をもちつつ、当初両側に配置されていた排気管は、装甲板内部の下方に移された。左右フェンダー上に設置されていた装備品収納箱もまた、側面装甲板と一体になる形に変更された。車体後部の乗降口もハッチが大きくなり、その傾斜角も大きくとられた。さらに武装はMG34からMG42へと変更された。1943年から終戦までの間に、総計10602輛のD型が生産されたが、この数字はそれ以前の、A、B、C、すべての型の生産数の合計を上回るものであった。D型をベースとして、さまざまなバリエーションタイプが開発され、それらの車輛は、大戦後期のドイツ機械化部隊の根幹を支える存在だったのである。

早在二次大戰爆發前，德國陸軍便發覺極需一種具有足夠的越野能力，能夠伴隨戰車運動的裝甲運輸車輛，除了能夠搭載一個步兵班的乘員外還必須具備適當的火力與防護力，在這些前題下，同時綜合評估了德國當時的工業能力，Sd. Kfz. 11 3t牽引車雀屏中選被擇定成為未來運兵車的雛型。1937年Sd. Kfz. 251/1 Ausf. A登場，車身四周覆以傾斜裝甲，兩側有可開閉的射擊槍眼，油箱的容量比起3t牽引車也加以提昇，車前後各配置一挺MG 34機槍，為了降低車身的高度，駕駛的方向盤被修改駛的方向盤被修改成向下方傾斜，除了車內的兩名乘員外，還能夠搭載10名步兵，同時還保留修改的餘地。

稍晚出現的Ausf. B與Ausf. C在車前方的機槍上安裝了防盾，生產期間由1937年延續至1943年，1943年出現的Ausf. D採用了更為簡化的車身結構以提昇生產效率，原本於車頭兩側的引擎的散熱口被隱藏在裝甲之下，車身兩側的儲物箱也與車身裝甲融為一體，車後方的出入口也更加的擴大以利進出，固定武裝也由MG34改為MG42。Ausf. D自1943年至大戰結束總共生產了10602台較之其它三型的總合還多，也為了不同的戰術需求而衍生出許多的車種，整個系列的車輛構成德軍二戰期間運輸的骨幹。

### Illustration: 圖示說明



### Method For Applying Decals:

1. Clean Model Surface With Wet Cloth.
2. Cut Out Of Decal Sheet And Dip Them In Water For 15 Seconds.
3. Place it on proper position on model.
4. Slide off base paper leaving decals On Model With Wet Finger Tip.
5. Move Decals To Exact Position, Push Out Excess Water Under Decal With Soft Cotton Cloth.
6. When Decals Get Dry Then Complete.

### 水貼紙使用說明:

1. 將模型表面擦乾淨
2. 將貼紙剪下泡入清水中約15秒
3. 將泡濕之貼紙取出置於欲貼處旁
4. 用指尖輕推貼紙表面使其滑出底紙
5. 將貼紙調整至適當位置並輕擦拭水份
6. 待其自然乾燥後即完成

### Color list: 塗料表

Color	Brand	GSI Creos (Gunze Sangyo)			Humbrol	Revell	Life Color
		Hobby Color	Mr. Color	Mr. Color Spray			
Wood brown	木棕	H-37	C-43	J-43	34	05	UA085/ UA125
Dark green	深綠	H-36/H-405	C-70	J-70	149	363	UA083
Dark yellow	深黃	H-79	C-39	J-39	83	16	UA081
Steel	黑鐵	H-18	C-28	J-28	53	91	LC76
Tire black	輪胎黑	H-77	C-137		85	302	LC02
Red brown	紅褐	H-47	C-41	J-44	160	383	UA082
Metallic green	亮綠	H-89	C-77	J-77	131	364	
Red	紅	H-3	C-3	J-3	19	31	LC56
Flat white	消光白	H-11	C-62	J-62	34	05	LC01
RLM02 Gray	灰	H-70	C-60		92	79	UA071

### AFV CLUB Sd.Kfz.251 track set (workable)

Early-modle	Late-modle	Latest-modle (Steel type)	Latest-modle (Rubber type)
AF 35044	AF 35069	AF 35070	AF 35081

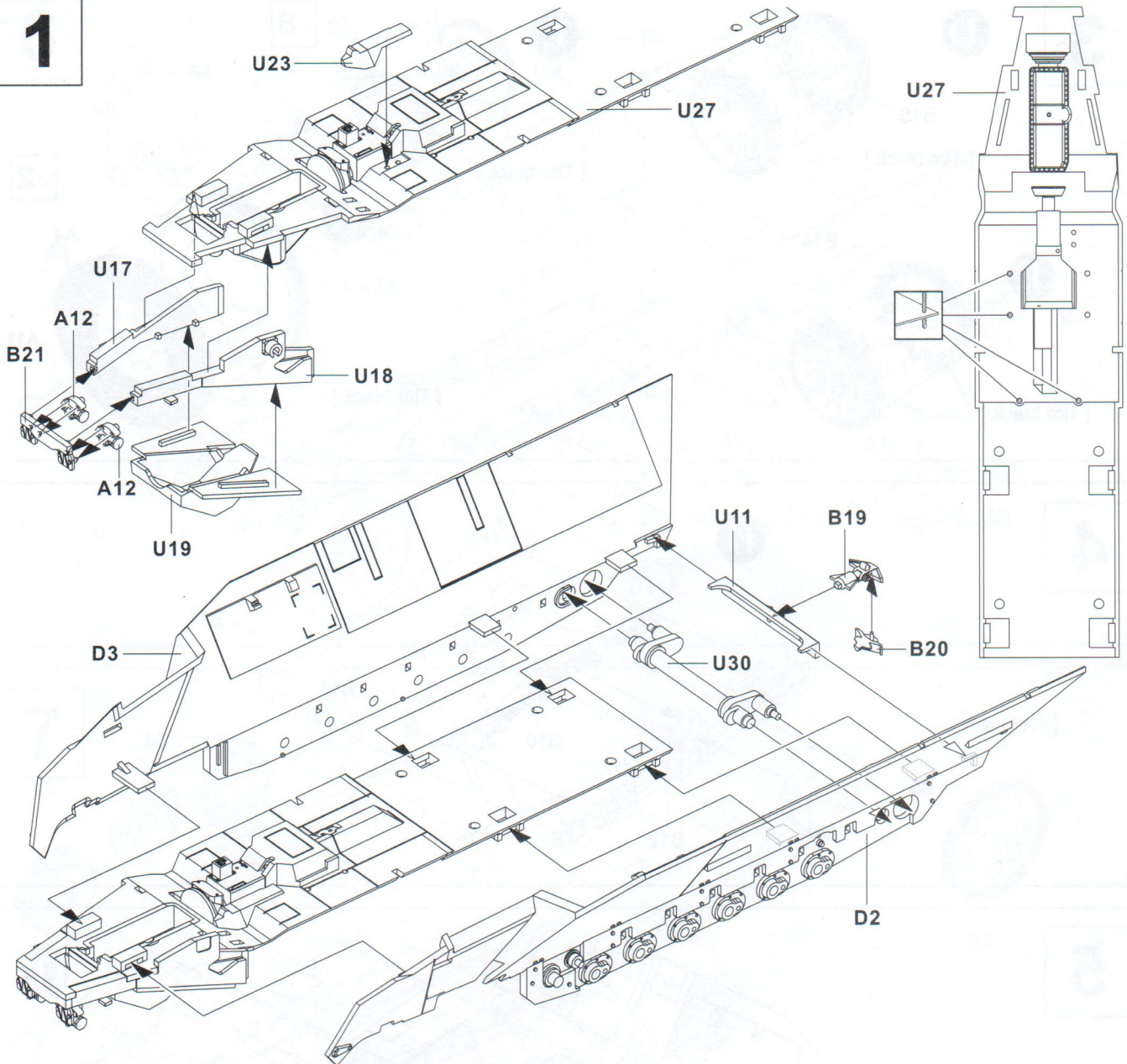
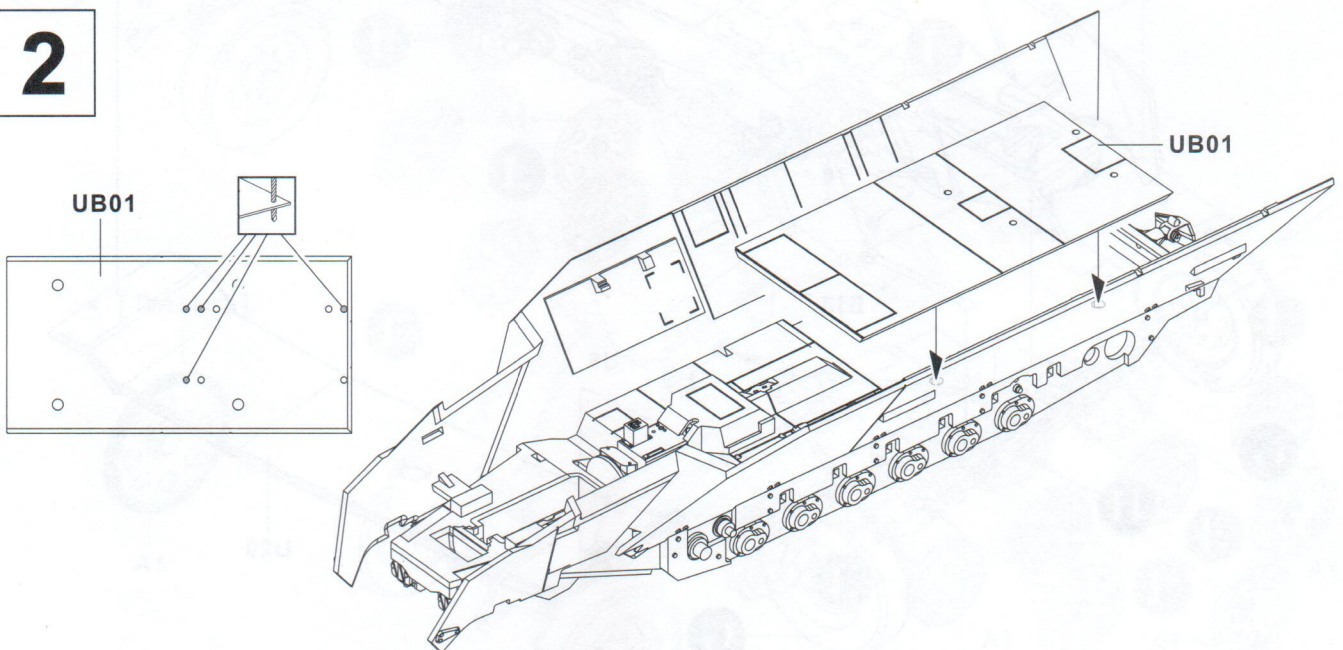
**1****2**

3

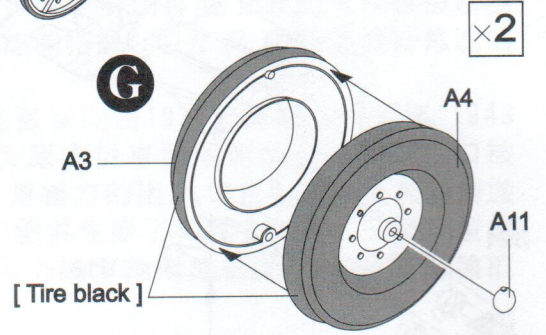
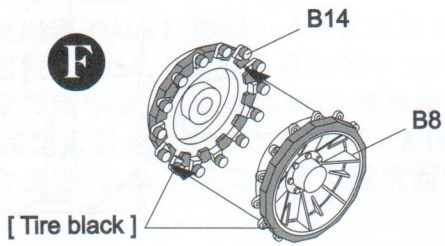
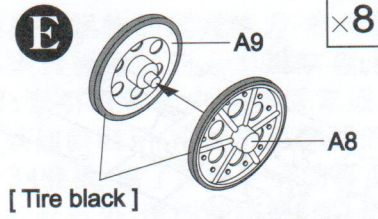
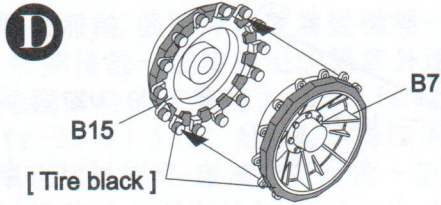

4

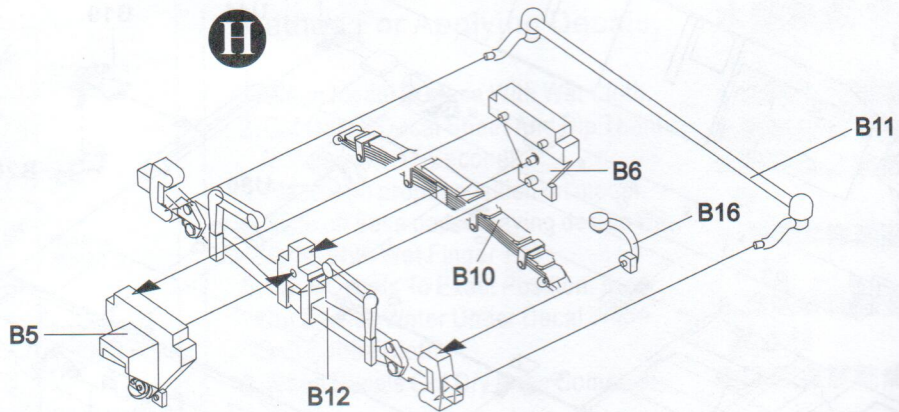

5

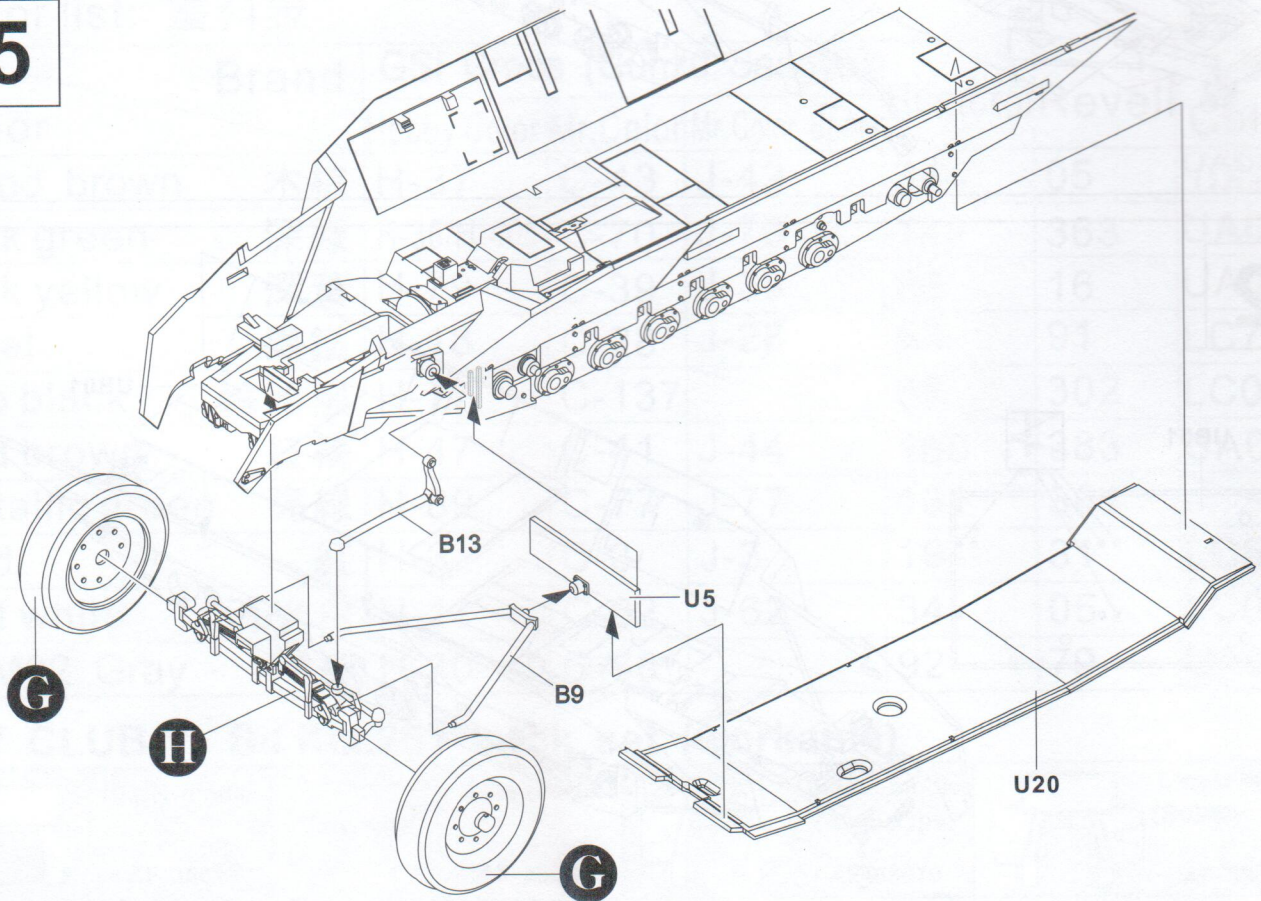

6

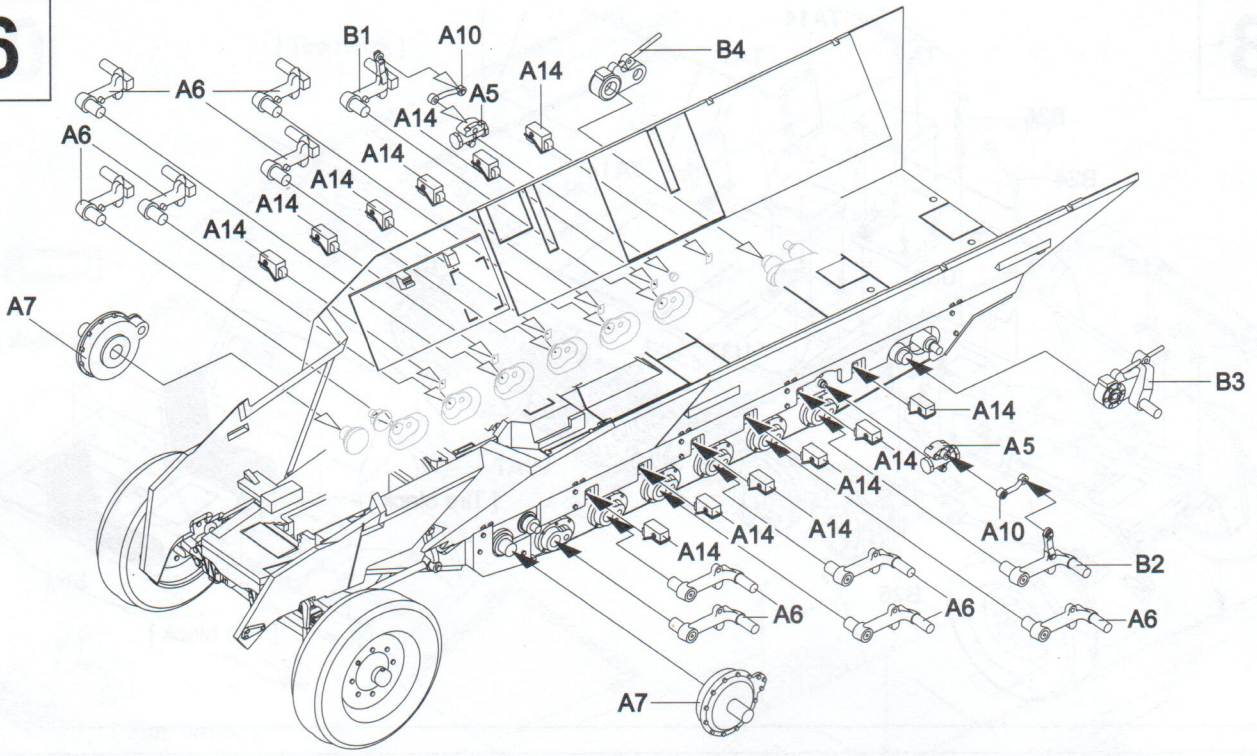

7

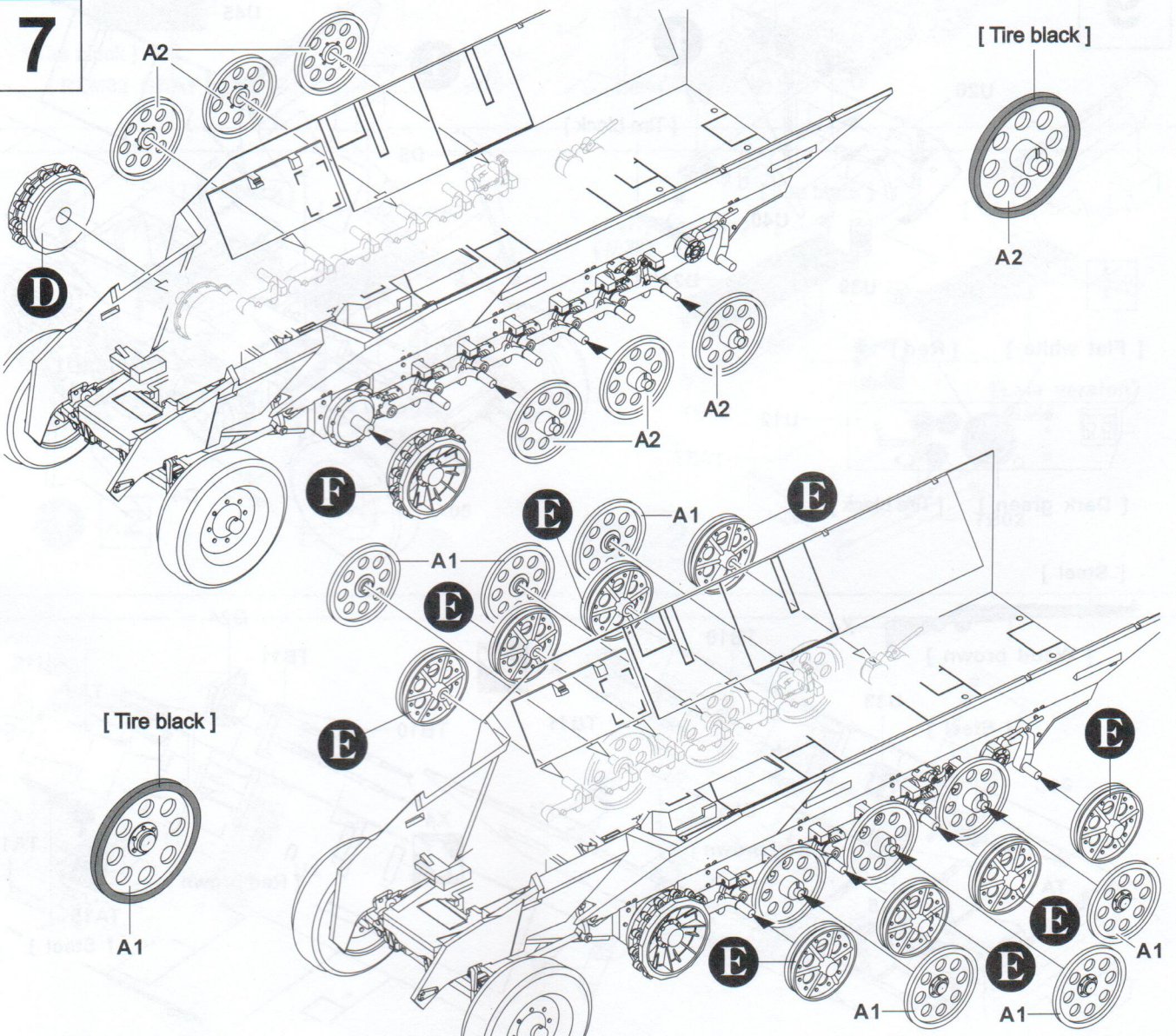

8

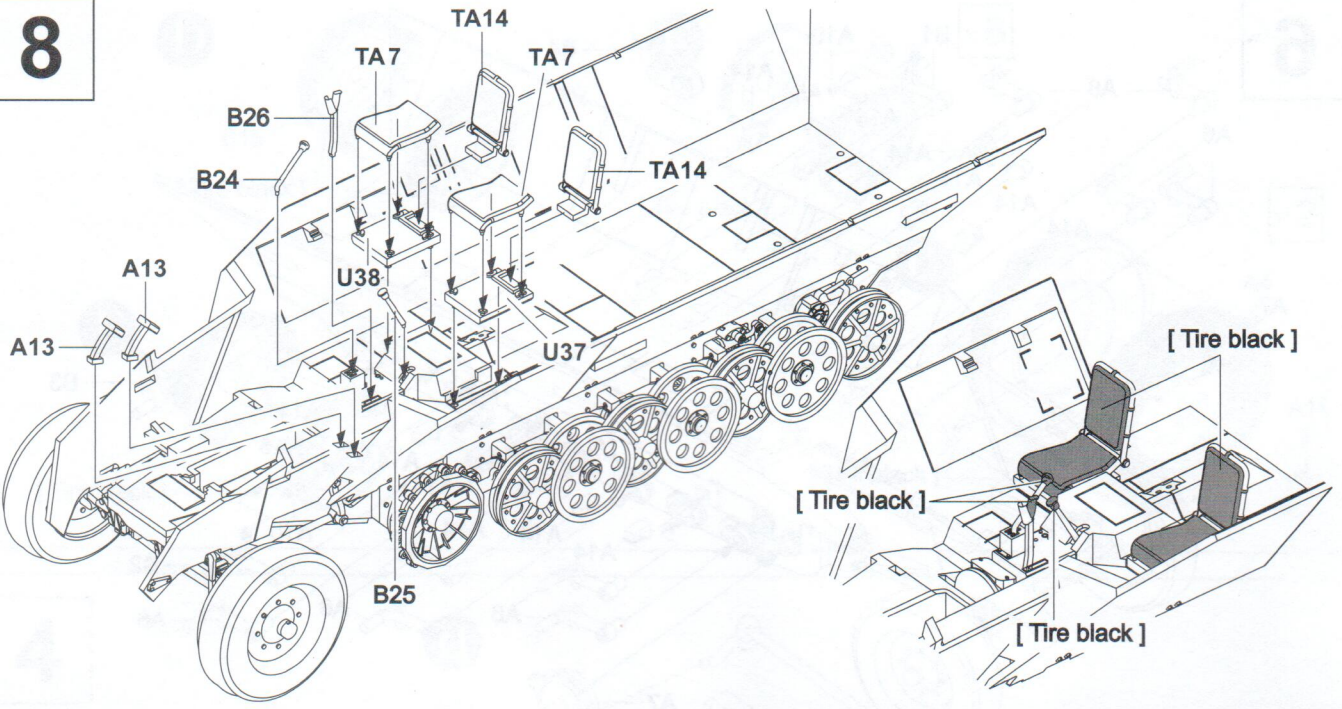

9

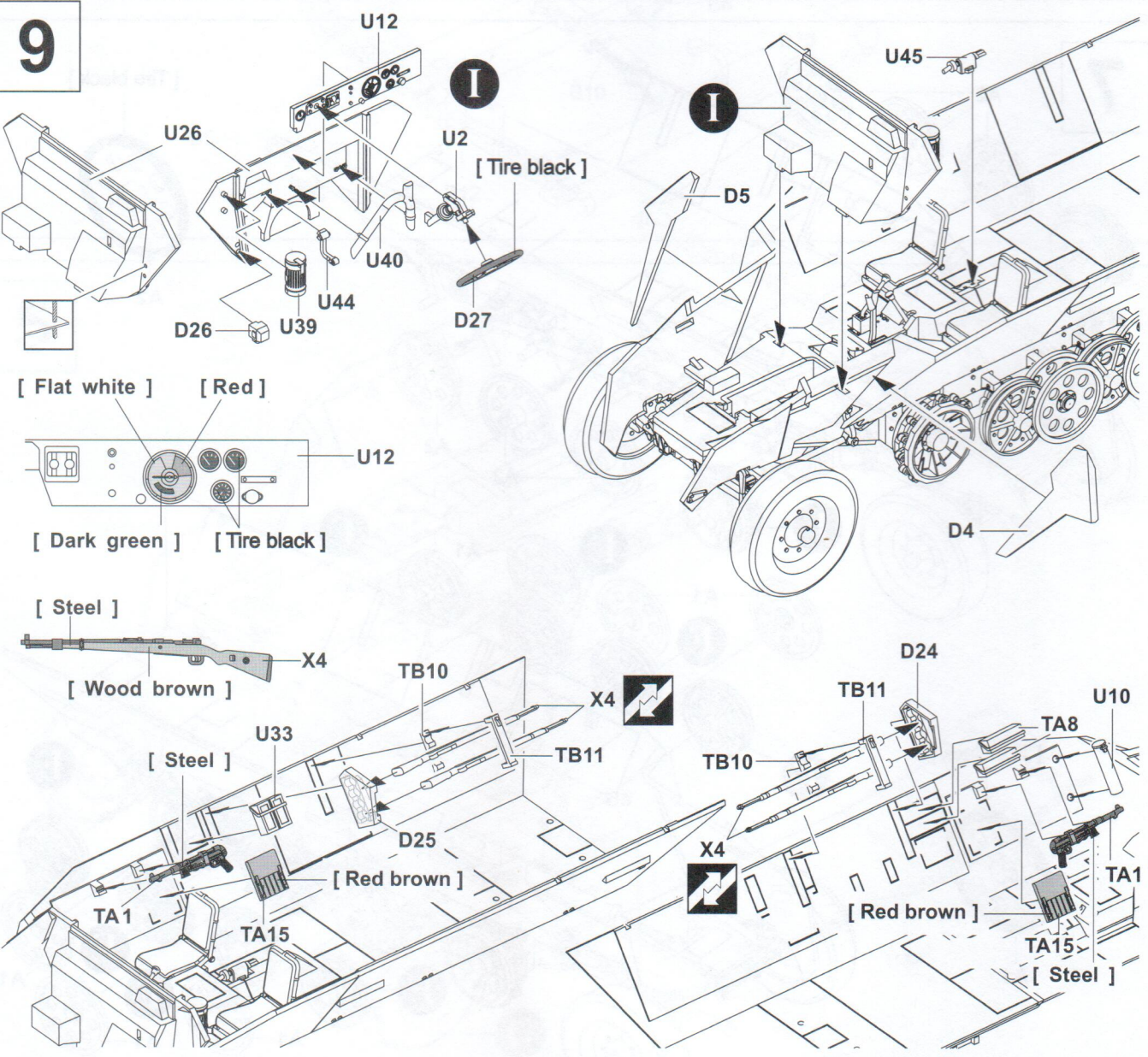

# 10

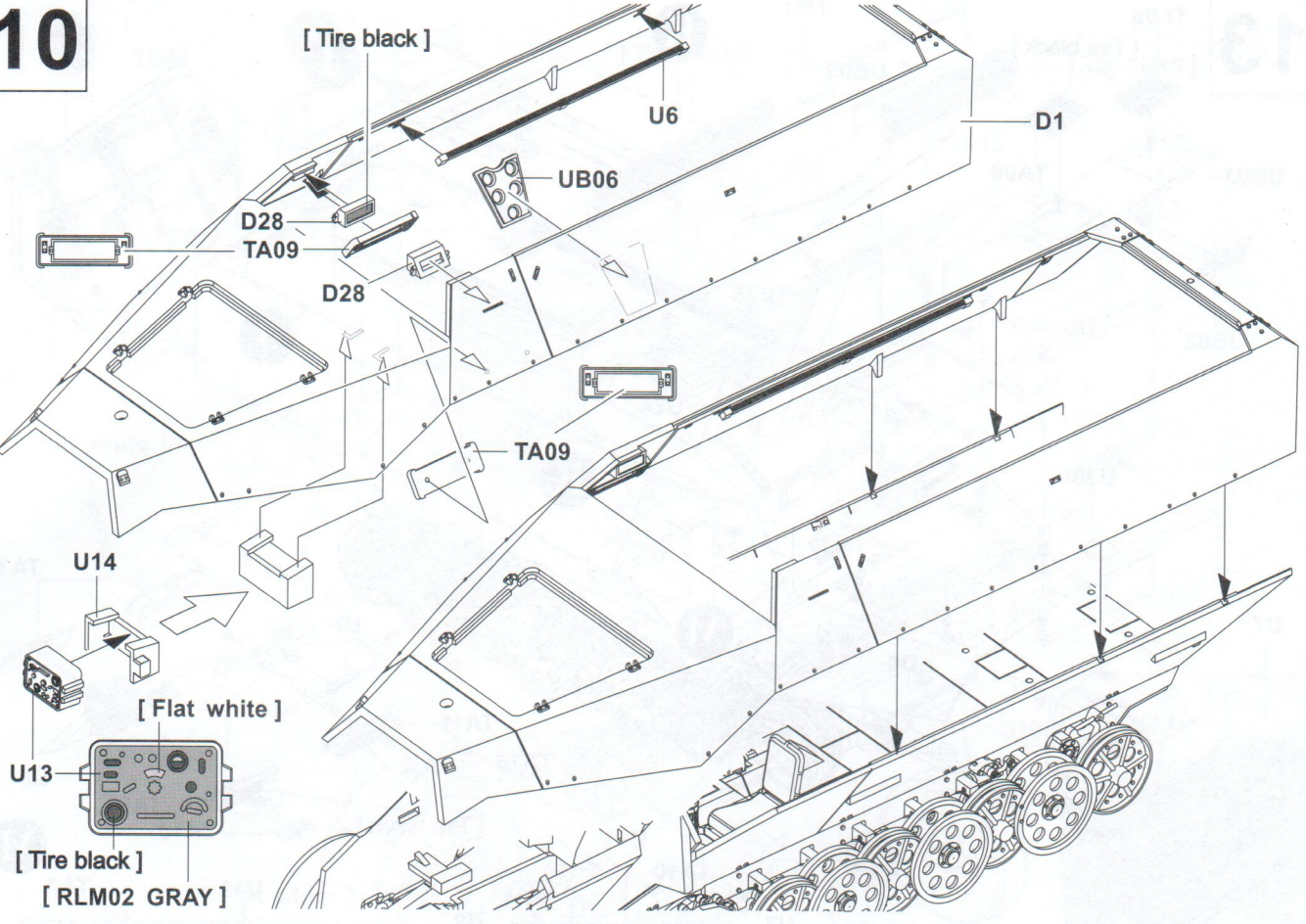

# 11

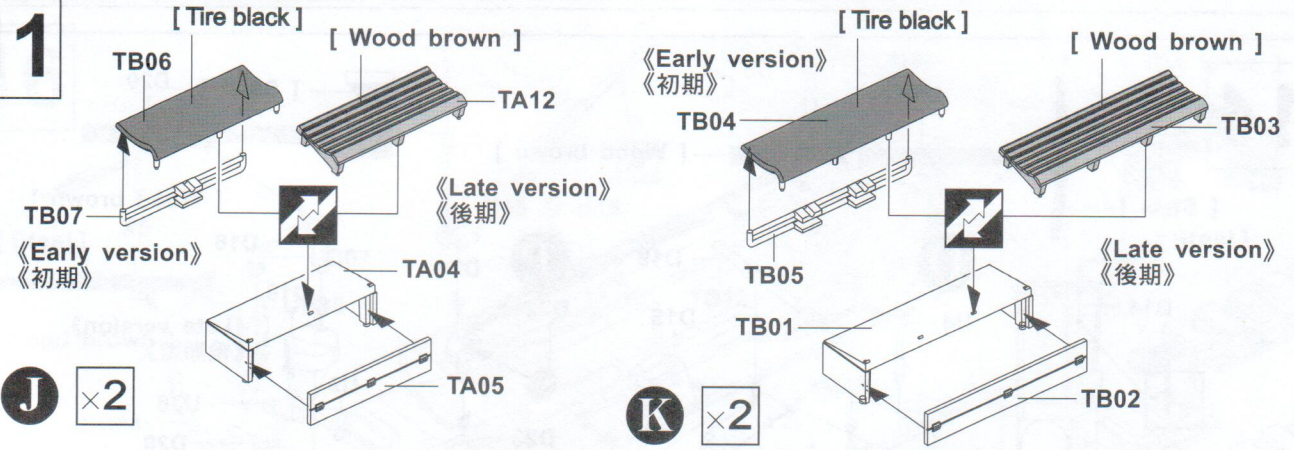

# 12

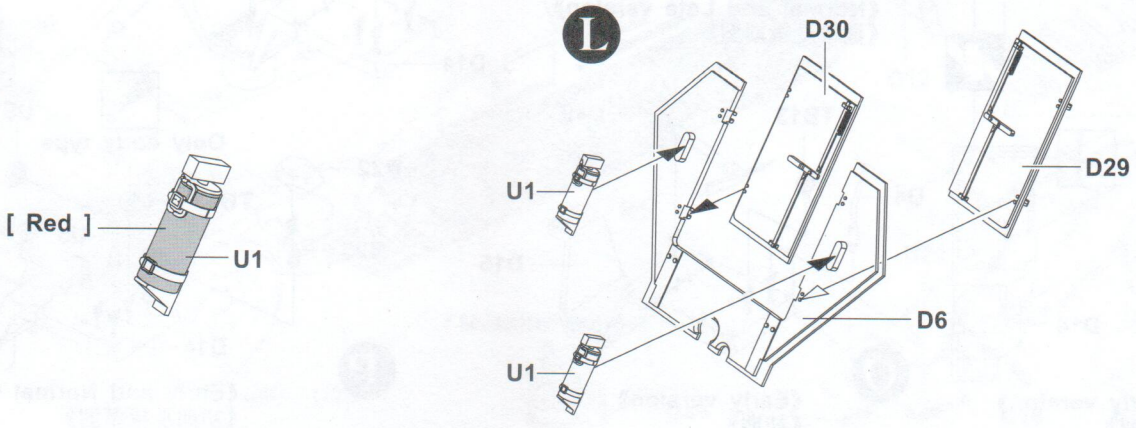

# 13

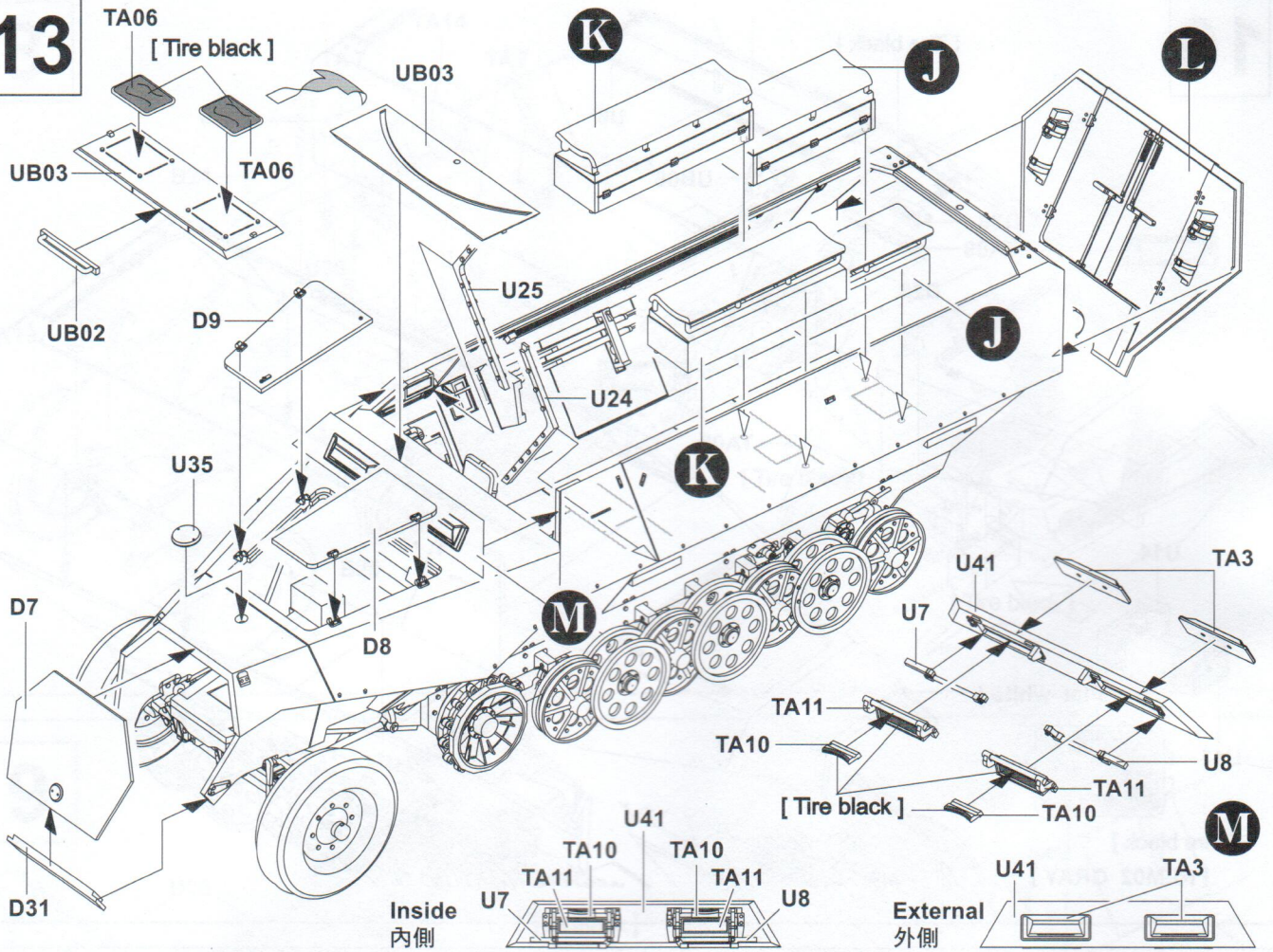

# 14

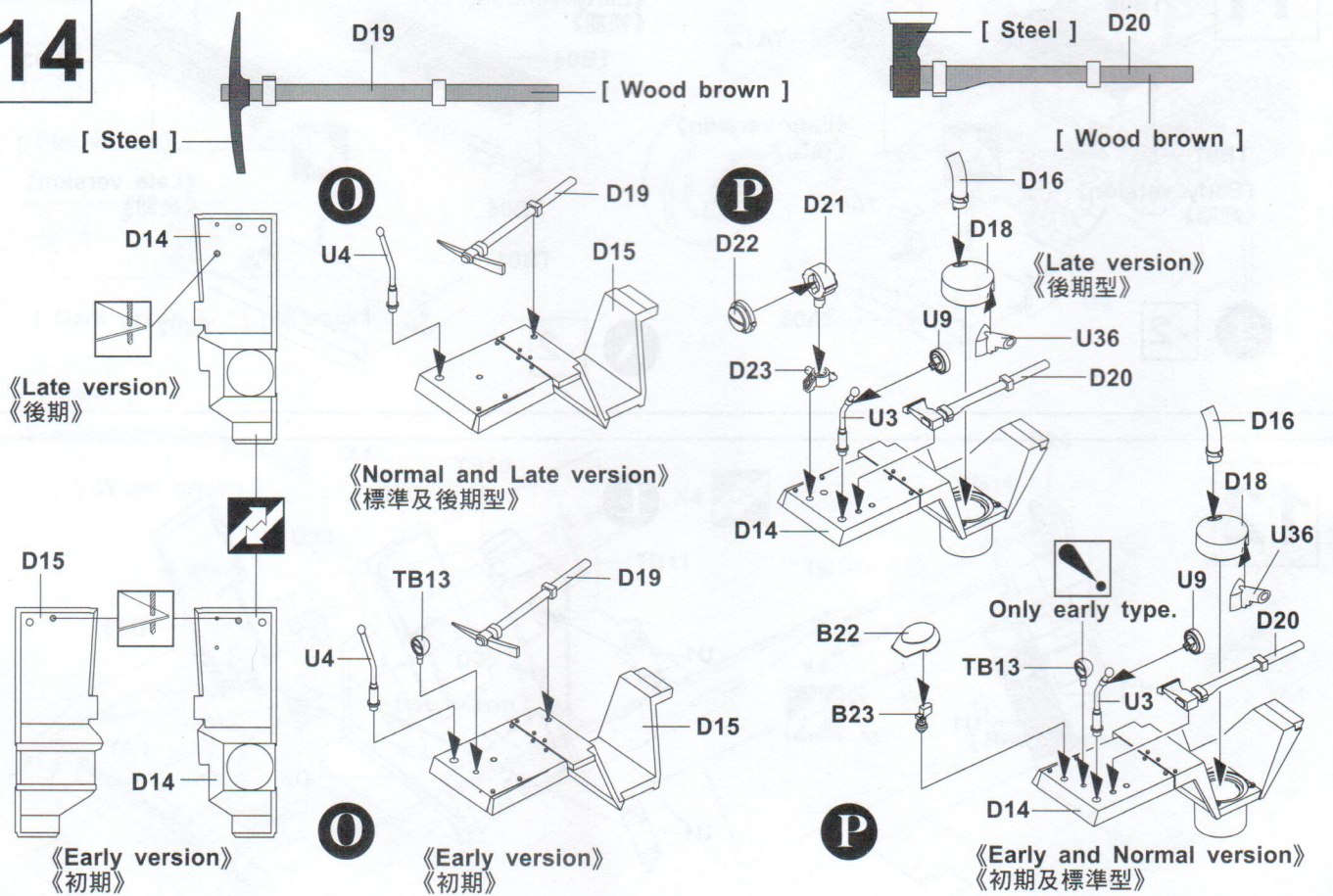



15

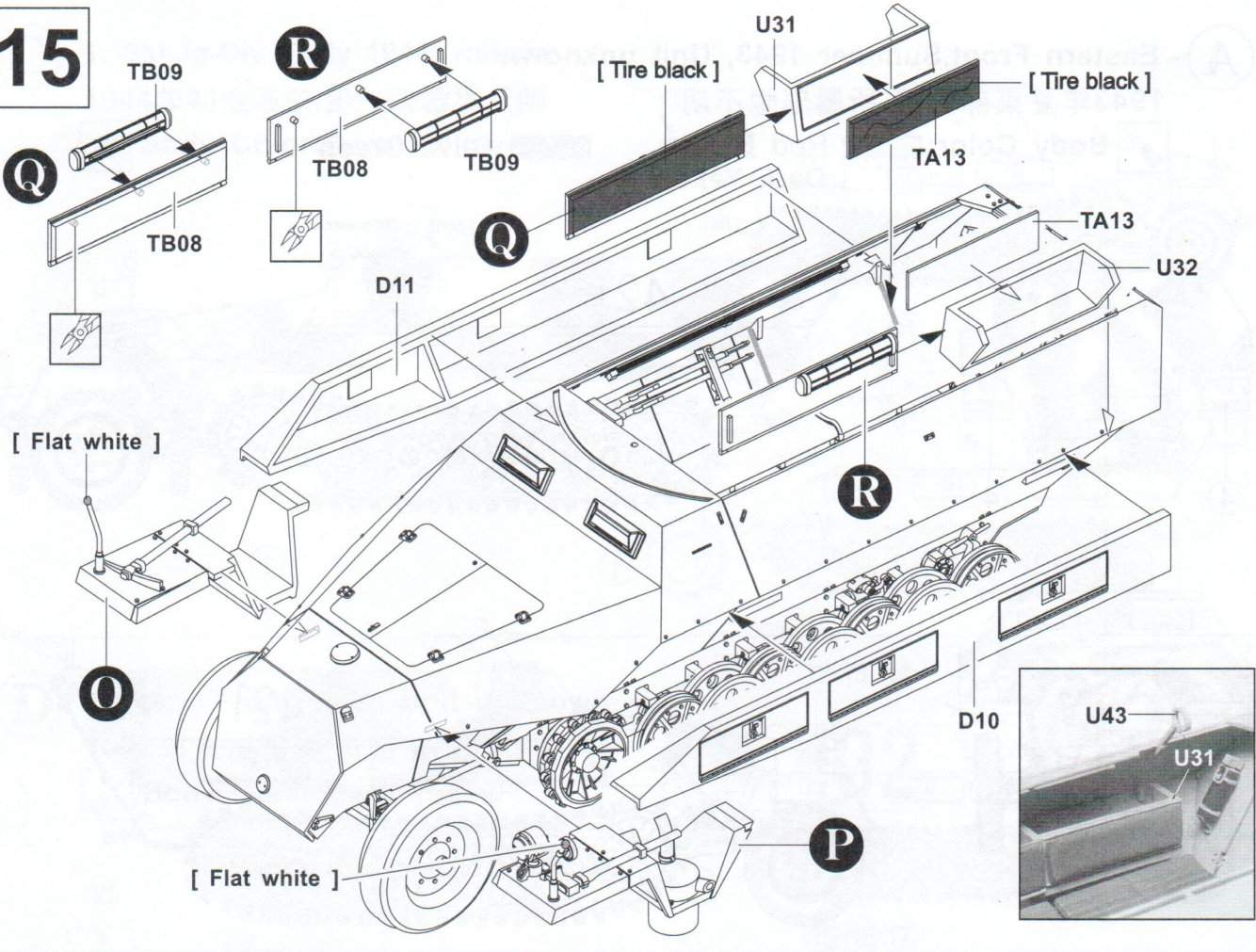

16

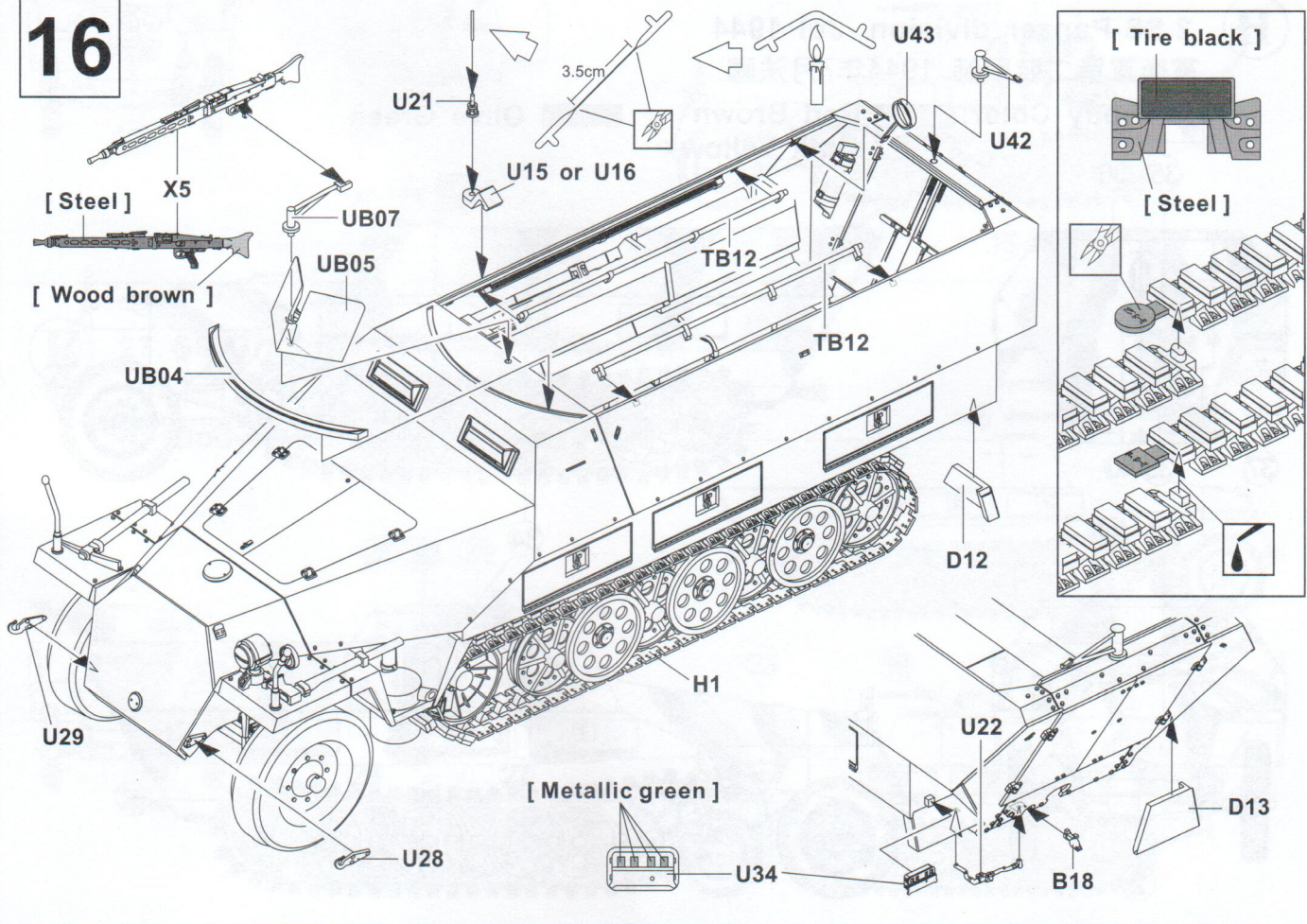

**A**

Eastern Front, Summer 1943, Unit unknown

1943年夏東部戰線, 所屬部隊不明



Body Color: Red Brown Olive Green  
 Dark Yellow

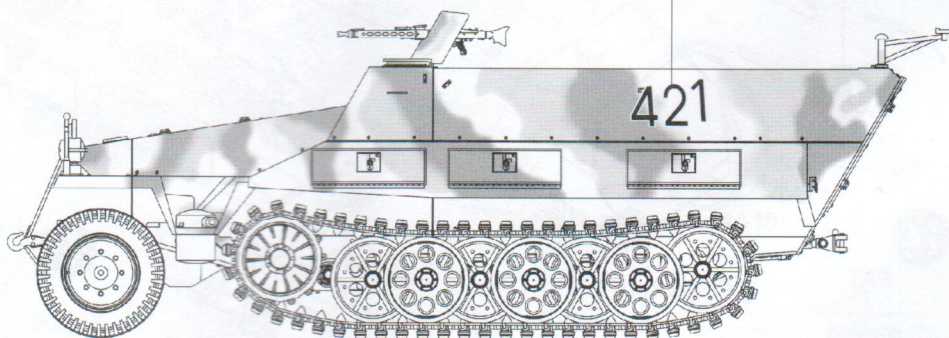
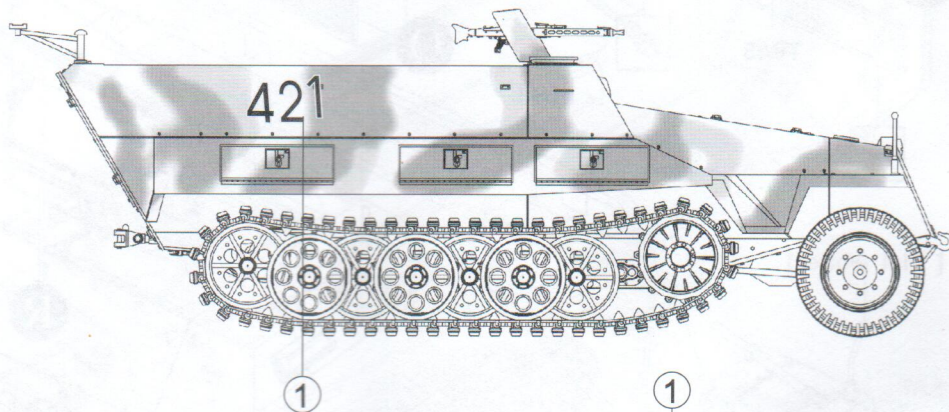
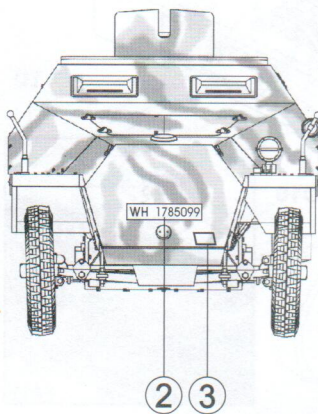
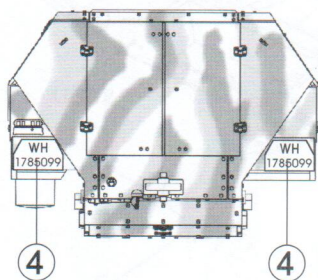

**B**

2.SS-Panzer division Jul 1944

黨衛軍第二裝甲師, 1944年7月法國



Body Color: Red Brown Olive Green  
 Dark Yellow

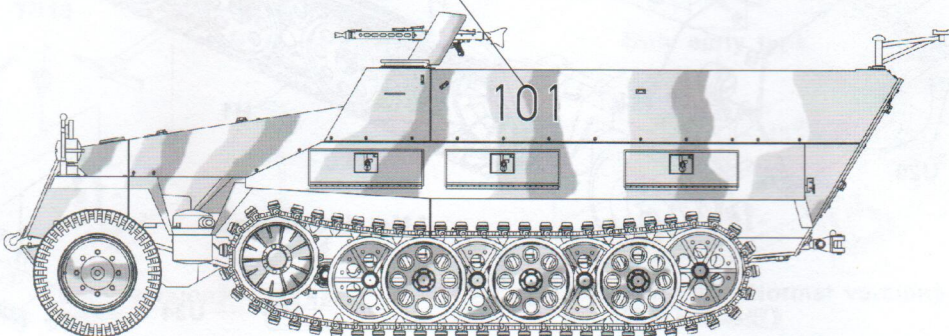
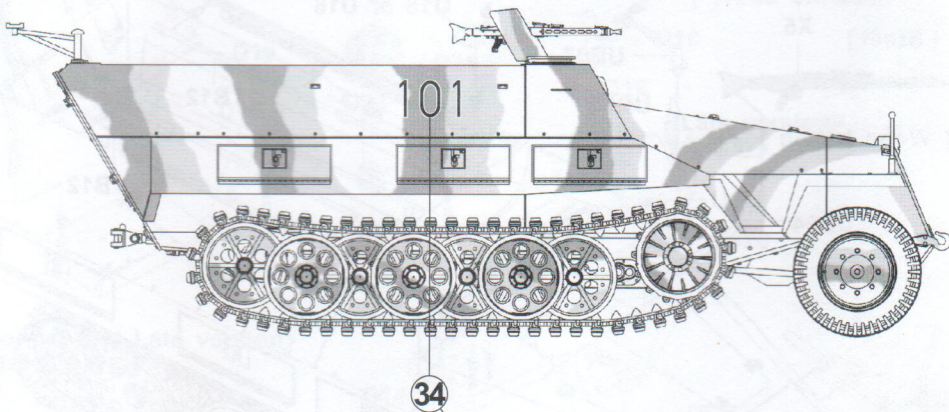
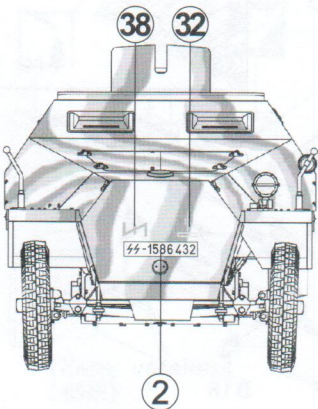
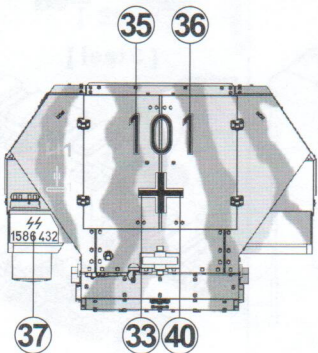

**C** 1. Ski-Jg-Div Early 1944, Russia  
 1944年初俄羅斯,第一滑雪獵兵師  
 Body Color: Dark Yellow

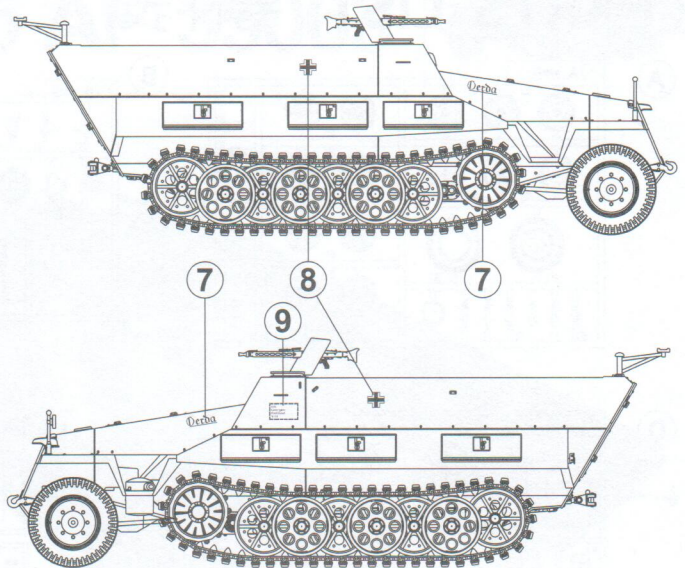
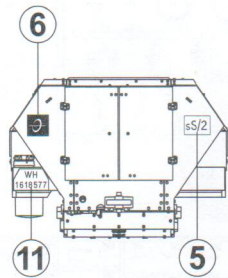
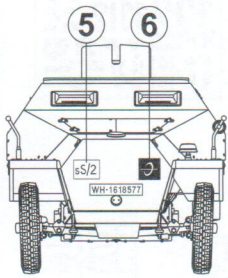

**D** Eastern Front 1944, Unit unknown  
 1944年東部戰線,所屬部隊不明  
 Body Color: Dark Yellow

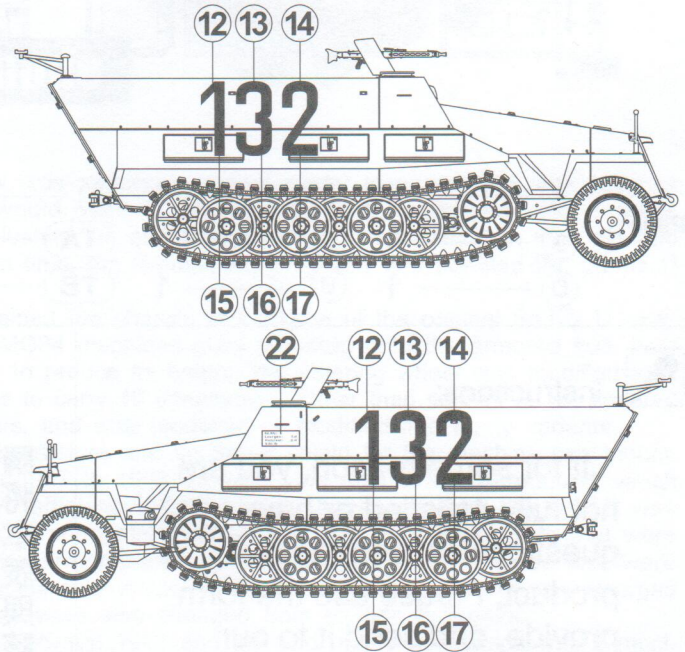
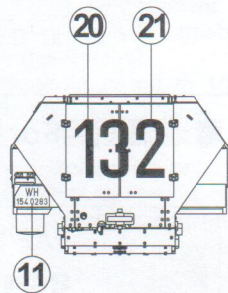
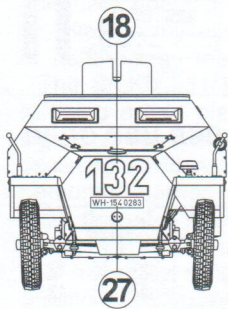

**E** 27. SS-Gren.Div. 1944~1945, Warsaw  
 1944~1945年華沙,黨衛軍第27義勇擲彈兵師,  
 Body Color: Dark Yellow

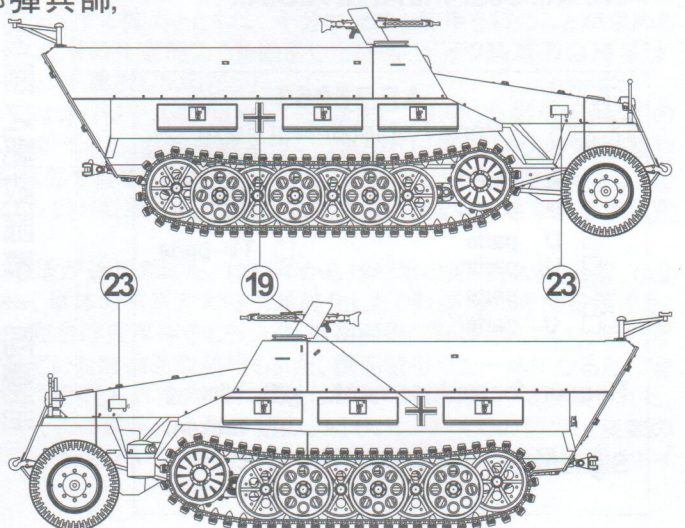
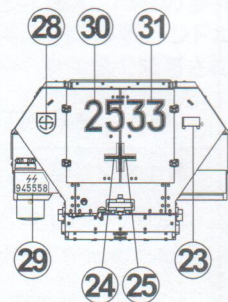
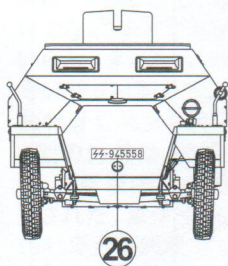

# PARTS LIST 零件表

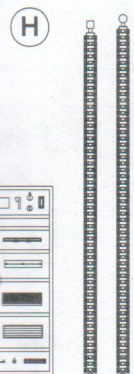
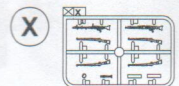
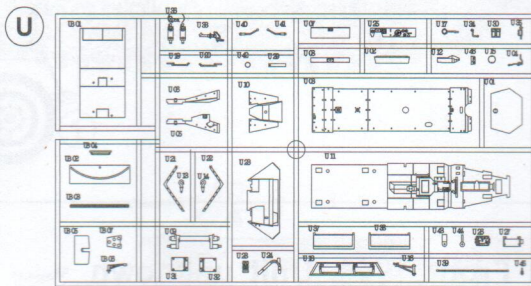
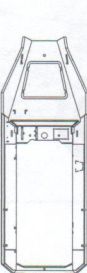
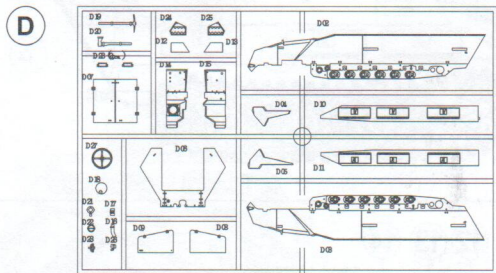
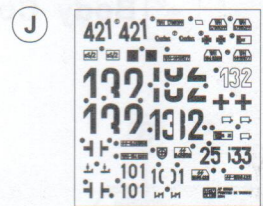
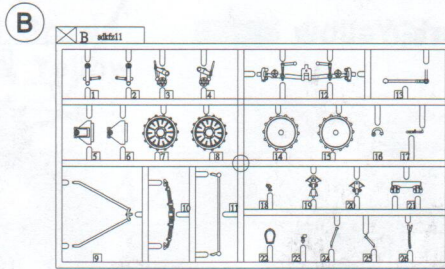
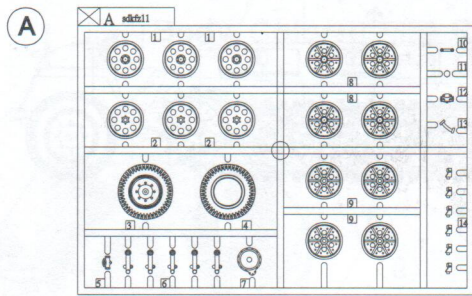

Parts :

A	2	H	1	X	2
B	1	J	1	TA	2
D	1	U	1	TB	2



## Instructions:

If for some reason, you are not fully satisfied or have questions concerning our product; Please use the form provide, and send it to our nearest representative or mail it directly to our office.

We will deal with that A.S.A.P.

限台灣地區使用 For Taiwanese use only!

總代理：戰鷹企業 客服部收 本公司將盡速為您處理  
請將本表與該部品相同金額之郵政匯票一同寄至

### AF 35063

#### Parts Replacement Form

<input type="checkbox"/> A parts	<input type="checkbox"/> X parts
<input type="checkbox"/> B parts	<input type="checkbox"/> TA parts
<input type="checkbox"/> D parts	<input type="checkbox"/> TB parts
<input type="checkbox"/> H parts	
<input type="checkbox"/> J parts	
<input type="checkbox"/> U parts	

Reason for replacement:  Missing  broken

Signature: \_\_\_\_\_

### AF 35063

零件補充申請表

申請人

姓名 地址 電話

: : :

<input type="checkbox"/> A部品零件	NT\$ 280
<input type="checkbox"/> B部品零件	NT\$ 120
<input type="checkbox"/> D部品零件	NT\$ 180
<input type="checkbox"/> H部品零件	NT\$ 160
<input type="checkbox"/> J部品零件	NT\$ 160
<input type="checkbox"/> U部品零件	NT\$ 160
<input type="checkbox"/> X部品零件	NT\$ 120
<input type="checkbox"/> TA部品零件	NT\$ 120
<input type="checkbox"/> TB部品零件	NT\$ 120

請填 總計 NT\$ \_\_\_\_\_

零件補充原因: 請於  打✓

· 原包裝即  遺失或  毀損 .

· 製作途中  遺失或  毀損 .

·  補充多餘零件 .

其他原因 \_\_\_\_\_