

JA 37 JAKTVIGGEN

F Le prototype a fait son 1er vol le 8 février 1967. Cinq versions sont actuellement en service dans l'armée de l'air Suédoise.

- AJ 37 version d'attaque tout temps
- SK 37 biplace d'entraînement
- SF 37 reconnaissance photographique
- SH 37 surveillance maritime tout temps
- JA 37 version perfectionnée

Le modèle présenté ici est équipé d'un réacteur RM8B avec post combustion, d'un radar-doppler et de quatre missiles Sidewinder.

Longueur:	16,30 m
Envergure:	10,60 m
Hauteur:	5,60 m
Vitesse maximum:	2200 km/h à 12000m

D Der Prototyp der Jaktviggen machte seinen ersten Flug am 8. Februar 1967. In der schwedischen Luftwaffe sind zur Zeit fünf verschiedene Versionen

der Jaktviggen im Einsatz:

- AJ 37 ständige Einsatzbereitschaft
- SK 37 zweisitzige Trainingsflugmaschine
- SF 37 Aufklärungsfotografien
- SH 37 ständige Seeüberwachung
- JA 37 modifizierte Version

Das Modell, das hier vorgestellt wird, ist ausgestattet mit einem Düsenantrieb RM&B mit Nachbrenner, einem Radar-Doppler und vier ferngelenkten Sidewinder Raketen.

Länge	16,30 m
Spannweite	10,60 m
Höhe	5,60 m
Max. Geschwindigkeit	2200 km/Std. auf 12000 m.

NL Het prototype voerde op 8 februari 1967 zijn eerste vlucht uit. Op dit ogenblik zijn er vijf versies in dienst bij de Zweedse Luchtmacht.

- AJ 37 aanvalversie in alle weersomstandigheden
- SK 37 tweepersoonsoefenvliegtuig
- SF 37 fotografische verkenning
- SH 37 zeebewaking in alle weersomstandigheden
- JA 37 geperfectioneerde versie

Dit model is uitgerust met een RM8B reactor met naverbranding, een doppler radar, twee Sky Flash en vier Sidewinder raketten.

I Il prototipo ha avuto il battesimo dell'aria l'8 Febbraio 1967. Cinque versioni di questo aereo sono state adottate dalle Forze Aeree svedesi:

- AJ 37, versione d'attacco con qualunque tempo
- SK 37, biposto di esercitazione
- SF 37, ricognizione fotografica
- SH 37, sorveglianza marittima con qualunque tempo
- JA 37, versione perfezionata

Il modello che qui presentiamo è dotato di un reattore RM8B a combustione posticipata, di un radar-doppler, di due Sky Flash e di quattro missili Sidewinder.

GB The prototype made its first flight on the 8th February 1967. Five versions are at present in service in the Swedish Air Force.

- AJ 37 All-weather attack version
- SK 37 Training two-seater
- SF 37 Photographic reconnaissance
- SH 37 All-Weather maritime Surveillance
- JA 37 Perfected version

The model shown here has a reactor with after burner, a radar-doppler and four Sidewinder missiles.

-Length	16.30 m
-Wingspan	10.60 m
-Height	5.60 m
-Maximum speed	2200 kph at 12000 m

E El prototipo ha hecho su primer vuelo el día 8 de febrero de 1967, estando en la actualidad cinco versiones en servicio en el ejército del aire Sueco:

- AJ 37 versión de ataque todo tiempo
- SK 37 biplaza de entrenamiento
- SF 37 reconocimiento fotográfico
- SH 37 vigilancia marítima todo tiempo
- JA 37 versión perfeccionada

El modelo que presentamos está equipado de un reactor RM8B con postcombustión, un radar-doppler y cuatro misiles Sidewinder.

Longitud	16,30 m
Envergadura	10,60 m
Altura	5,60 m
Velocidad máxima	2200 km/h a 12000 m

GR Το πρωτότυπο έκανε την πρώτη του πτήση στις 8 Φεβρουαρίου 1967. Η πολεμική αεροπορία της Σουηδίας χρησιμοποιεί σήμερα πέντε τύπους:

- το AJ 37: τύπος μαχητικού αεροσκάφους για όλες τις καιρικές συνθήκες
- το SK 37: διαθέσιμο εκπαιδευτικό αεροσκάφος
- το SF 37: φωτογραφική αναγνώριση
- το SH 37: επίβλεψη επί της θαλάσσης για όλες τις καιρικές συνθήκες
- το JA 37: τελειοποιημένη έκδοση

Το μοντέλο που παρουσιάζεται αερωθούμενο κινητήρα RM8B με μετάκαυση, με radar-doppler, δύο Sky Flash και τέσσερις πυραύλους Sidewinder.

P O protótipo fez o seu primeiro voo em 8 de Fevereiro de 1967. Estão actualmente em serviço cinco versões na aviação Sueca.

- AJ 37 versão de ataque todos os tempos
- SK 37 bilugar de treinamento
- SF 37 reconhecimento fotográfico
- SH 37 vigilância marítima todos os tempos
- JA 37 versão aperfeiçoada

O modelo aqui apresentado está equipado com um reator RM8B com post combustão, um radar doppler, dois Sky Flash e quatro misseis Sidewinder.

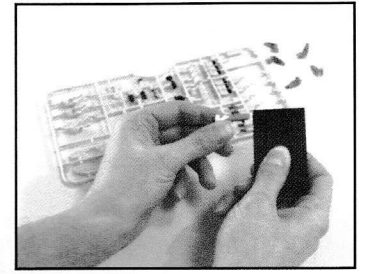
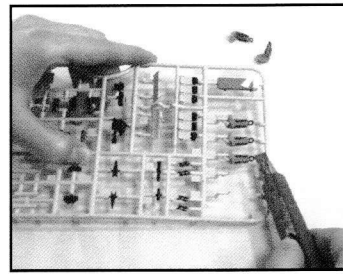
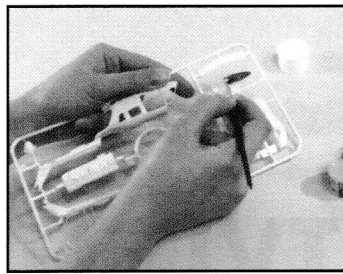
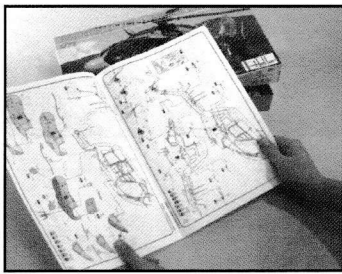

F Lire attentivement les instructions de la notice.

F Peindre les petites pièces sur leur support.

F Détacher les pièces selon l'ordre de montage.

F Poncer les points d'attache.

GB Read the instruction manual with care.

GB Paint the small parts on their support.

GB Detach the parts in the order of assembly.

GB Sand the attaching points.

D Lesen Sie die Anweisungen sorgfältig durch.

D Streichen Sie die kleinen Teile auf deren Halterung an.

D Lösen Sie die Teile in Montager Reihenfolge.

D Schleifen Sie die Befestigungsstellen.

RUS Внимательно прочитайте инструкцию.

RUS Красьте мелкие детали на их подставке.

RUS Отсоединяйте детали в порядке сборки.

RUS Защищайте места соединений.

E Leer atentamente las instrucciones del fletó.

E Pintar las pequeñas piezas sobre su soporte.

E Desprender las piezas según el orden de montaje.

E Alisar los puntos de ajuste.

NL Lees de gebruikshandleiding aandachtig door.

NL Schilder de kleine onderdelen in het raamwerk.

NL Maak de onderdelen los volgens de montagevolgorde.

NL Schuur de hechtvlakken.

I Leggere attentamente le istruzioni d'uso.

I Verniciare i pezzi piccoli dopo averli posti sul supporto relativo.

I Staccar e i pezzi secondo l'ordine di montaggio.

I Levigare e i punti di attacco.

P Ler atentamente as instruções do folheto.

P Pintar as pequenas peças sobre o suporte.

P Desencaixar as peças respeitando a ordem de montagem.

P Polir os pontos de encaixe.

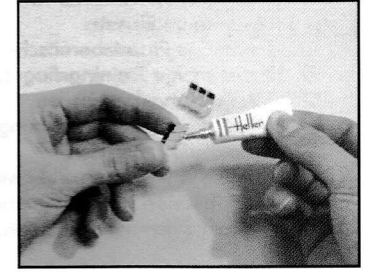
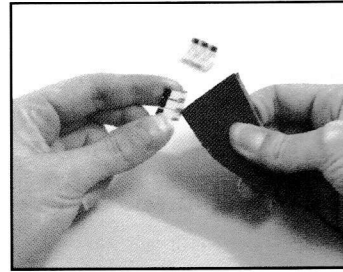
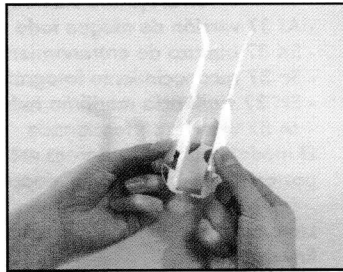
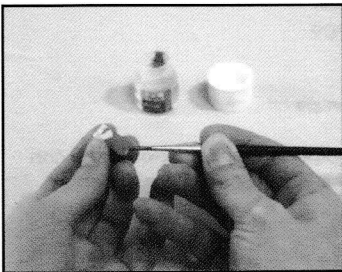

F Retoucher les points d'attache des pièces déjà peintes.

F Simuler l'assemblage.

F Poncer la peinture ou le chrome avant d'appliquer la colle.

F Utiliser la colle avec parcimonie.

GB Touch up the attaching points of painted parts.

GB Simulate the assembly.

GB Rub down the chromium paint before applying the glue.

GB Use glue sparingly.

D Streichen Sie die Befestigungspunkte der bereits angestrichenen Teile nach.

D Simulieren Sie die Montage.

D Schmirgeln Sie die Farbe oder den Chrom, bevor Sie den Kleber auftragen.

D Tragen Sie den Kleber stellenweise auf.

RUS Подкрасьте места соединений окрашенных деталей.

RUS Проверьте качество сборки.

RUS Перед нанесением клея сотрите хромовую краску.

RUS Пользуйтесь клеем экономно.

E Retocar los puntos de ajuste de las piezas ya pintadas.

E Simulare un ensamblaje.

E Lijar la pintura o el cromo antes de aplicar la cola.

E Utilizar la cola con moderación.



11
Argent
Silver
Silber



18
Orange
Orange
Orange



19
Rouge vif brillant
Gloss bright red
Glänzend-Hellrot



33
Noir mat
Matt black
Mattschwarz



34
Blanc mat
Matt white
Mattweiss



53
Gris métallique
Gunmetal
Metallgrau



127
Gris fantôme US satiné
Satin US ghost grey
Satin USA Schattengrau

1

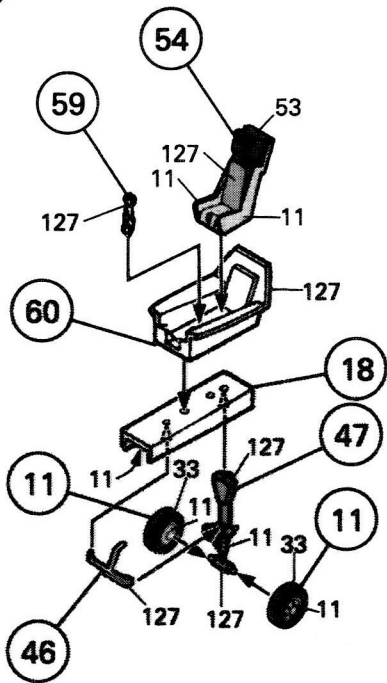

2

Phase de montage
 Assembly phase
 Fase de montaje
 Monteringsfase
 Montagephase
 Φάση συναρμολόγησης
 Fase di montaggio
 Montagefase
 Monterings
 Fase de montagem
 Kokoamisvaihe
 Monterings
 Montaż
 組立段階
 Этап сборки

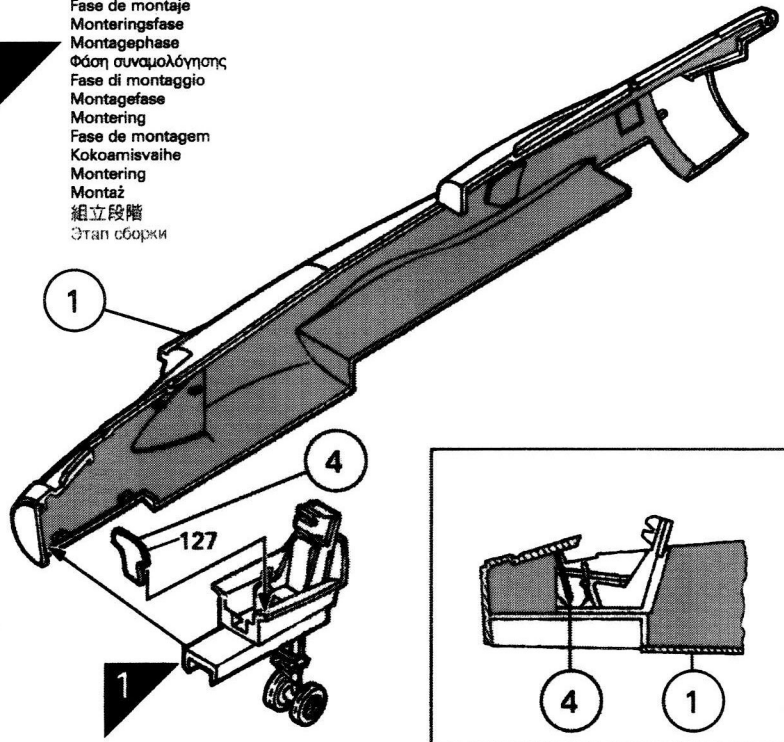

3

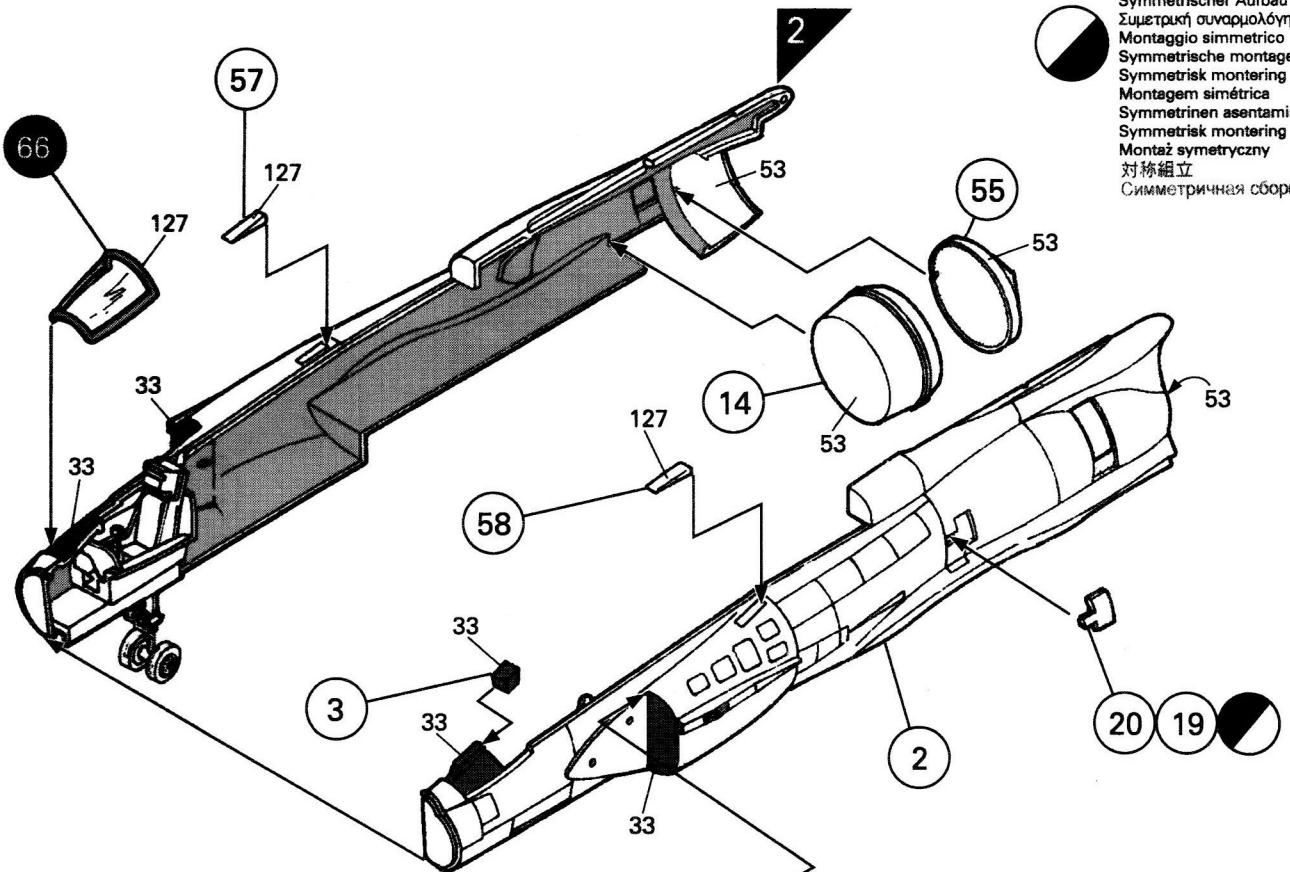

Montage symétrique
 Symmetrical assembly
 Montaje simétrico
 Symmetrisk samling
 Symmetrischer Aufbau
 Συμμετρική συναρμολόγηση
 Montaggio simmetrico
 Symmetrische montage
 Symmetrisk monterings
 Montagem simétrica
 Symmetrischen asentaminen
 Symmetrisk monterings
 Montaż symetryczny
 对称組立
 Симметричная сборка

00 Collier
 Cement
 Pegar
 Klæbe
 Kleben
 Συγκόλληση
 Incollare
 Lijmen
 Lime
 Colar
 Liimaa
 Limma
 Skleić
 接着して下さい
 Приклеить

00 Pièce cristal
 Crystal part
 Pieza cristal
 Krystallstykke
 Kistalteil
 Διαφανές κομμάτι
 Pezzo cristallo
 Kristallen onderdeel
 Kristallidel
 Peça de cristal
 Lasiosa
 Kristallidel
 Część przezroczysta
 クリスタル部品
 Хрустальная деталь

M1 = 34 + 127

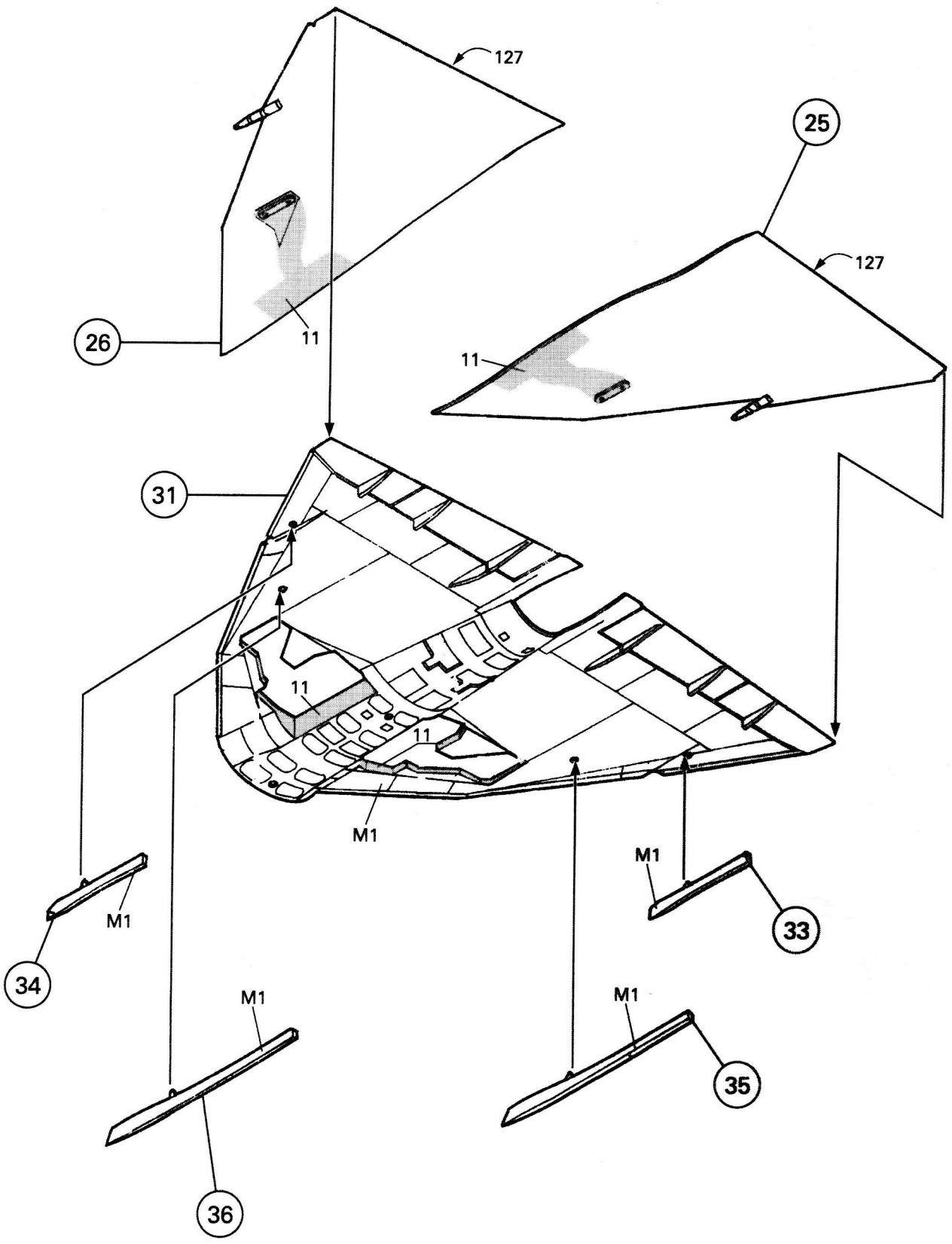

5

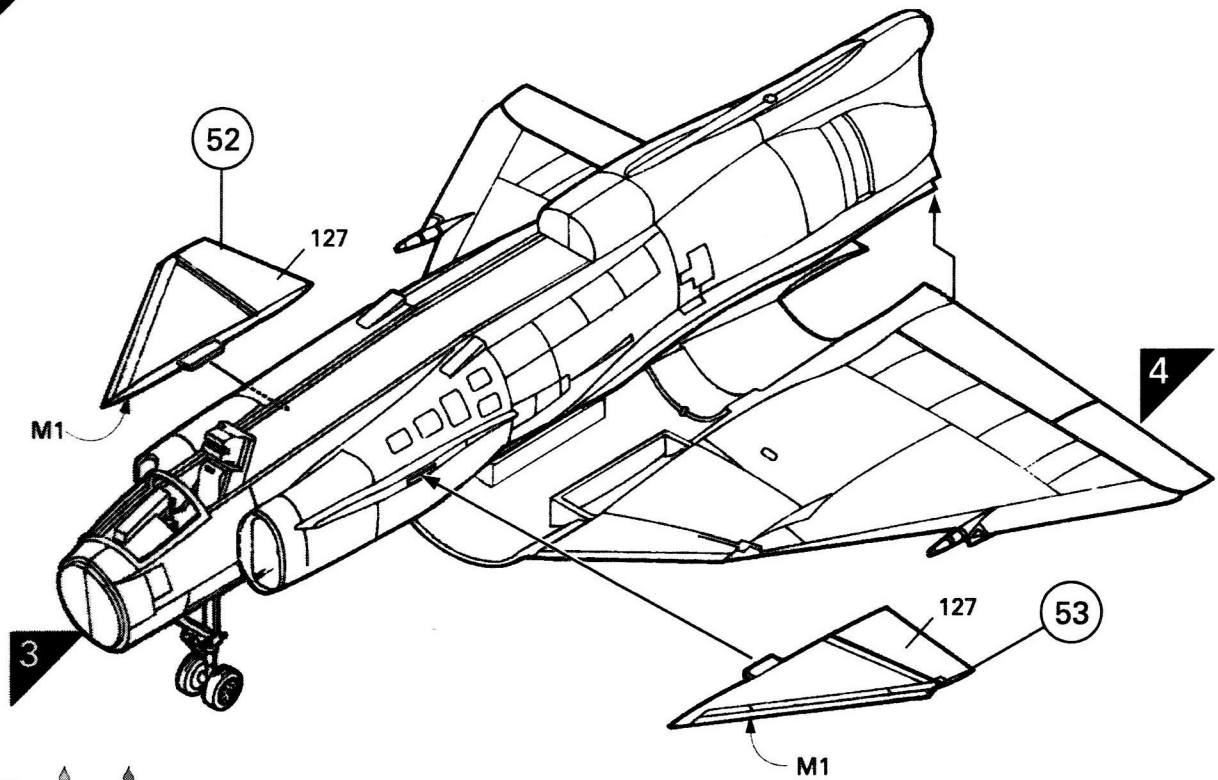

M1 = 34 + 127

6

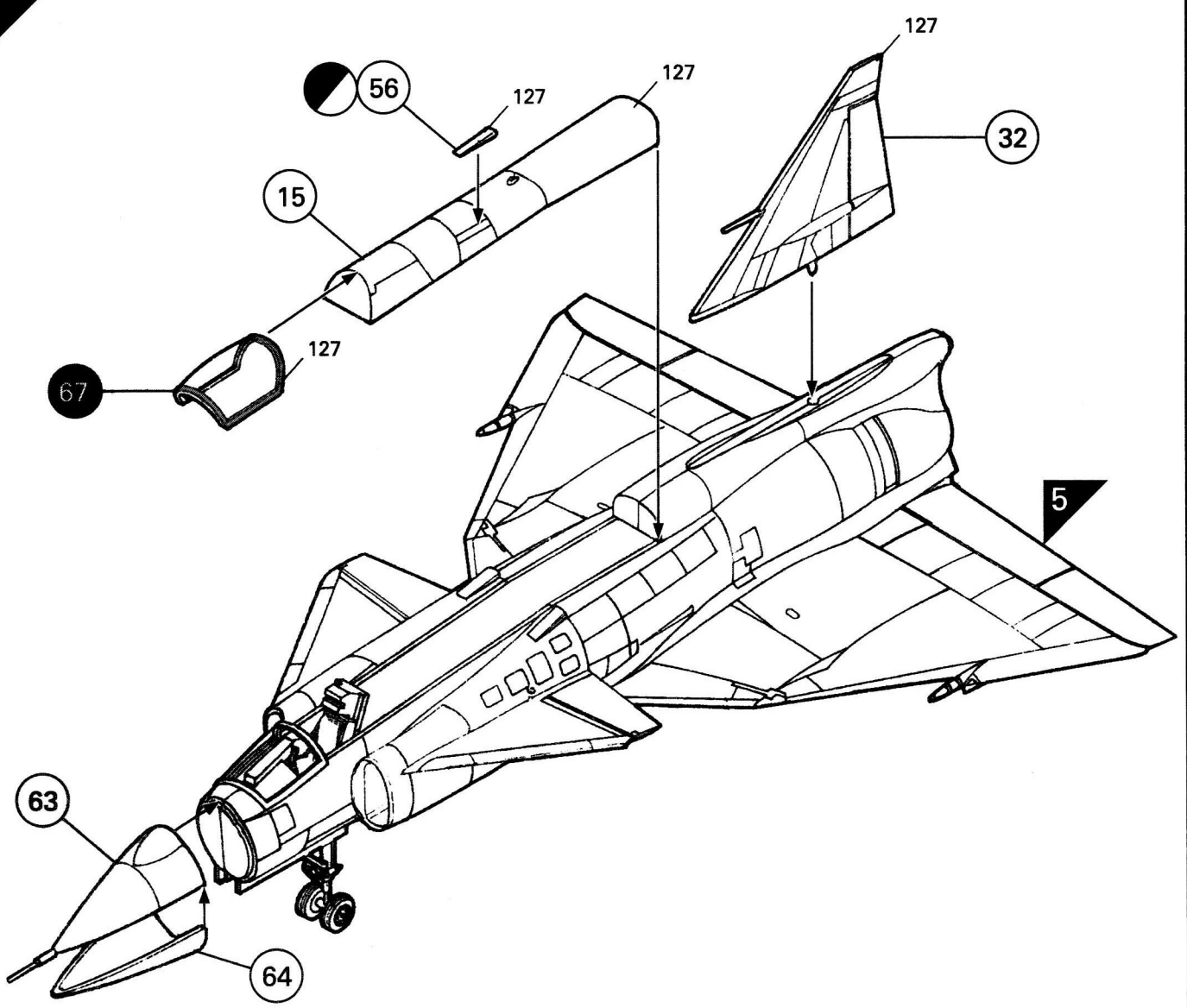

80309

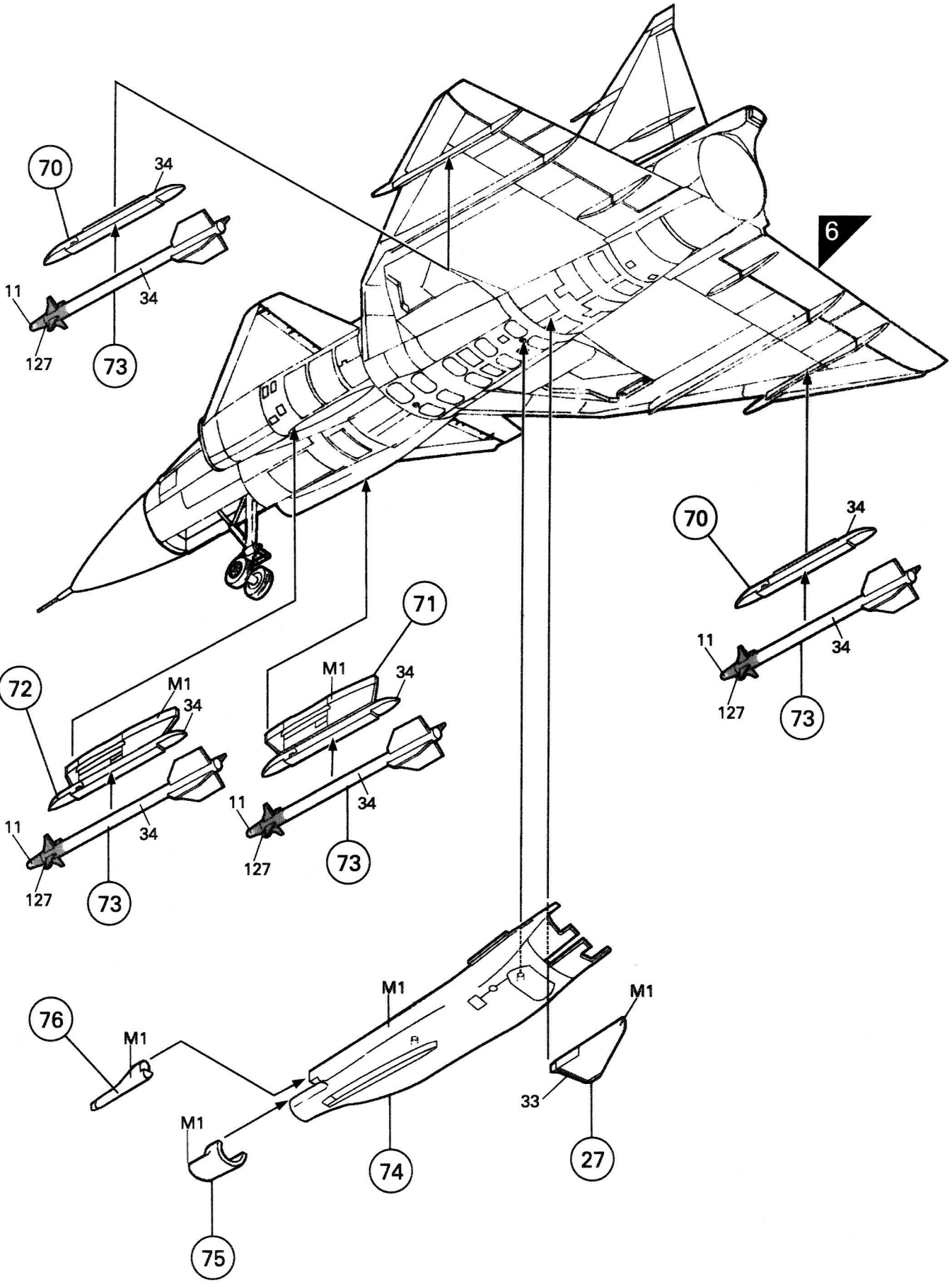

6

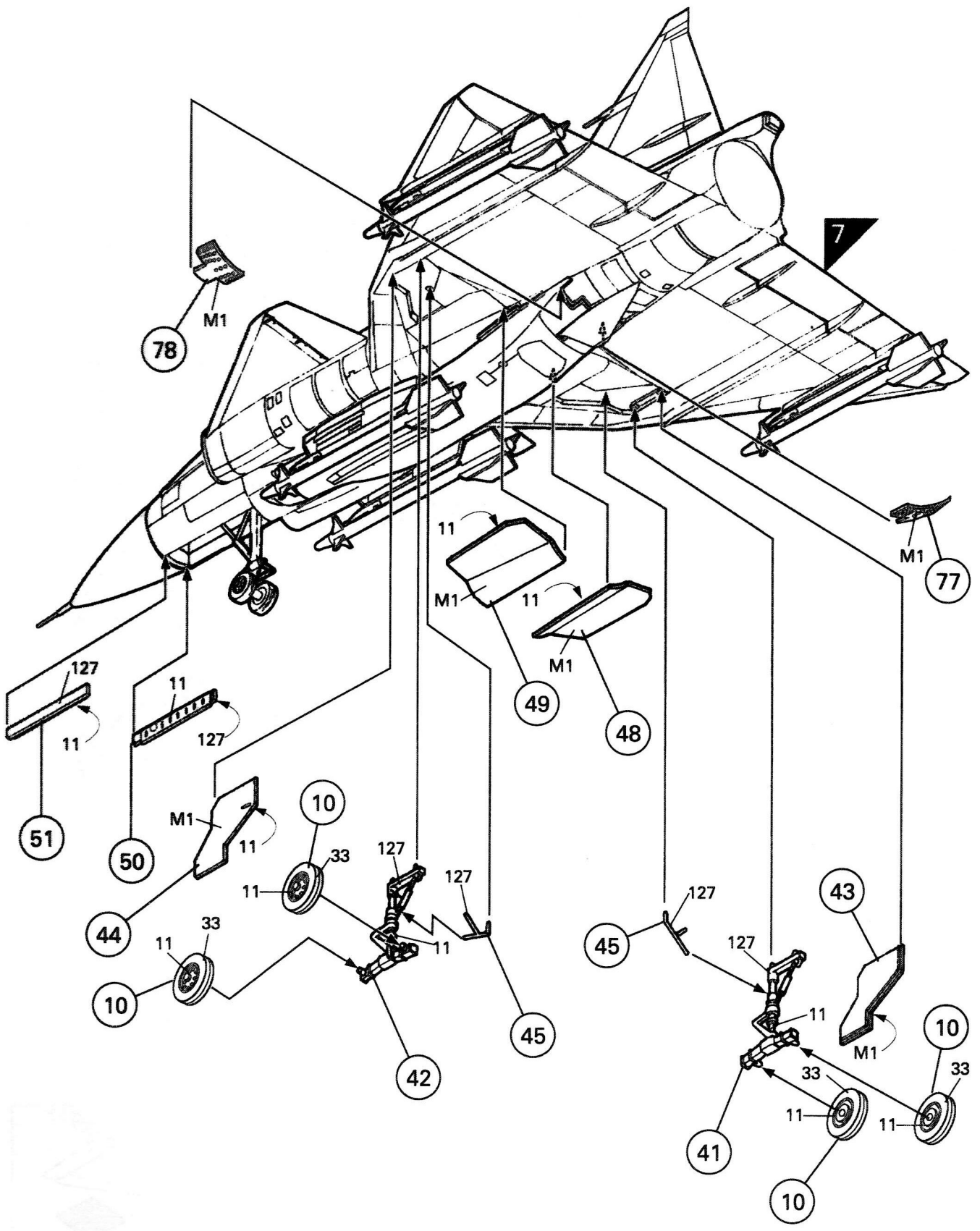

Decalcomanias
 Decals
 Calcomanias
 Billedoverføring
 Abziehbild
 Χαλκομανίες
 Decalcomanie
 Afdrukplastjes
 Bildeoverføring
 Decalcomania
 Siirtokuvet
 Dekalkomanier
 Kalkomanie
 写し絵
 Переводные изображения

Suède: Saab JA 37 Jaktviggen
 1 Jakflgdivisionen, Ronnebg, 1992

00

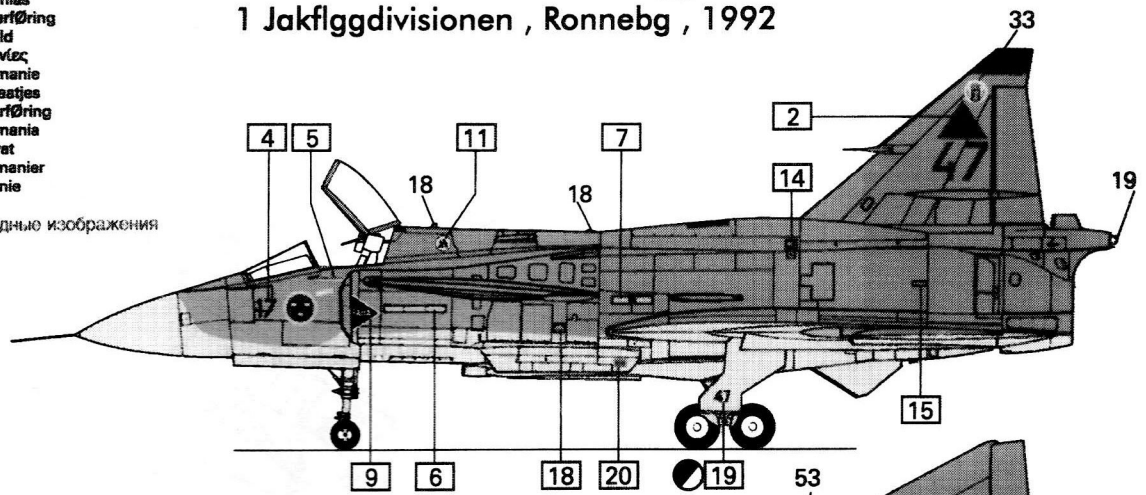

127
 M1 = 34 + 127

