

PRE-COLORED EDITION
脱色版

MENG
WWW.MENG-MODEL.COM

MECHA-006L



MULTIPURPOSE HUMANOID DECISIVE WEAPON, ARTIFICIAL HUMAN

EVANGELION PROTO TYPE-00'

汎用人形決戦兵器 人造人新世纪福音战士零号机 (改)

汎用ヒト型決戦兵器 人造人間エヴァンゲリオン 試作零号機 (改)

© khara

制作前必读

Read carefully before assembly

組み立て前に必ずお読みください。

Необходимо внимательно прочесть перед изготовлением модели

Vor der Montage bitte sorgfältig lesen

Lisez attentivement avant de monter

Lea cuidadosamente antes del montaje

- ❑ 本产品为拼接模型，需要使用模型专用工具自行组装。
- ❑ 本产品中不包含模型专用工具、胶水或颜料。如有需要，请另外购买。
- ❑ 制作产品前请仔细阅读手册，按照手册标明的步骤进行制作。低年龄制作者制作时需有成人看护，看护者请仔细阅读手册。
- ❑ 制作产品时请先确定零件编号，然后再使用剪钳将其从板件上取下，切勿一次取下多个零件，以免丢失或混淆，剩余的碎屑请妥善丢弃。
- ❑ 本产品中不包含电池。如有需要，请按照说明书指示的型号另外购买。
- ❑ 请勿对发光组件进行涂装，以免发光组件不能正常工作。

- ❑ This product is a plastic model kit. Please use hobby tools to assemble it.
- ❑ This product doesn't include any hobby tool, glue or paint. If needed, please purchase separately.
- ❑ Carefully read the instructions before commencing assembly and follow the instruction steps during the assembly process. Young modellers building this model kit shall be guided by adults. The supervising adults should carefully read the instructions too.
- ❑ Check part numbers before removing them from sprues with side cutters. To avoid losing or mixing up the parts, don't remove too many parts at a time. Please dispose the plastic residuals properly.
- ❑ This product doesn't include any battery. If needed, please purchase the battery as marked in the instruction manual separately.
- ❑ Do not paint the light. It may malfunction if painted.

- ❑ 本製品はプラスチックモデル組立キットであり、モデル専用の工具で組み立ててください。
- ❑ 本製品には、モデル用の工具、接着剤、または塗料が含まれていません。必要に応じて別途ご購入ください。
- ❑ 製品を組み立てる前にマニュアルをよく読み、マニュアルに記載された手順に従って作ってください。低年齢の方が作る際には保護者がサポートし、保護者は必ずマニュアルをお読みください。
- ❑ 製品を組み立てる際は、まず部品番号を確認してから、モデル専用ニッパーでランナーからきれいに切り離してください。紛失や混乱を避けるため、一度に複数の部品を切り取らないでください。切り取った後のごみは適切に廃棄してください。
- ❑ 本製品にはバッテリーは含まれていません。必要に応じて、マニュアルに記載されている型番に従って別途ご購入ください。
- ❑ 発光ユニットを正常に使用するため、塗装しないでください。

- ❑ Данное изделие предназначено для самостоятельной сборки. При сборке модели необходимо использовать специальные инструменты. В комплект данного изделия не входят краски, инструменты и клей. При необходимости приобретите отдельно.
- ❑ Пожалуйста, внимательно прочтите инструкцию перед началом сборки изделия и следуйте указаниям в инструкции. Моделистам младшего возраста требуется помощь взрослых.
- ❑ Во время сборки изделия перед отсоединением деталей, пожалуйста, сначала сверьтесь с номером детали, а затем, используя ножницы и плоскогубцы, снимите деталь с листа. Во избежание потери деталей или путаницы, не удаляйте одновременно несколько деталей.
- ❑ Оставшийся мусор утилизируйте в соответствии с инструкцией.
- ❑ В комплект данного изделия не входит батарейка. При необходимости приобретите отдельно в соответствии с маркой модели, указанной в инструкции.
- ❑ Не окрашивайте фары, во избежание нарушения работы световых приборов.

- Ⓜ Dieses Produkt ist ein Plastikmodellbausatz. Bitte verwenden Sie Hobby-Werkzeuge, um es zusammenzubauen.
- Ⓜ Dieses Produkt enthält kein Hobbywerkzeug, Kleber oder Farbe. Falls erforderlich, bitte separat kaufen.
- Ⓜ Lesen Sie die Anleitung sorgfältig durch, bevor Sie mit dem Zusammenbau beginnen, und befolgen Sie die Anweisungen während des Zusammenbaus. Junge Modellbauer, die diesen Bausatz bauen, sollten von Erwachsenen angeleitet werden. Die aufsichtführenden Erwachsenen sollten die Anleitung ebenfalls sorgfältig lesen.
- Ⓜ Überprüfen Sie die Teilenummern, bevor Sie die Teile mit dem Seitenschneider von den Angüssen entfernen. Um den Verlust oder die Verwechslung von Teilen zu vermeiden, entfernen Sie nicht zu viele Teile auf einmal. Bitte entsorgen Sie die Kunststoffreste ordnungsgemäß.
- Ⓜ Dieses Produkt enthält keine Batterie. Falls erforderlich, kaufen Sie die Batterie bitte separat, wie in der Bedienungsanleitung angegeben.
- Ⓜ Lackieren Sie das Licht nicht. Diese könnten ansonsten nicht richtig funktionieren.
- Ⓜ Ce produit est un kit de modèle en plastique. Veuillez utiliser les outils de loisirs pour l'assembler.
- Ⓜ Ce produit n'inclut aucun outil de loisir, colle ou peinture. Si nécessaire, veuillez l'acheter séparément.
- Ⓜ Lisez attentivement les instructions avant de commencer l'assemblage et suivez les étapes d'instructions pendant le processus d'assemblage. Les jeunes maquetistes construisant ce kit de modèle doivent être guidés par des adultes. Les adultes surveillants doivent également lire attentivement les instructions.
- Ⓜ Vérifiez les numéros de pièce avant de les retirer des tiges de coulée avec des pinces coupantes latérales. Pour éviter de perdre ou de mélanger les pièces, ne retirez pas trop de pièces à la fois. Veuillez jeter les résidus de plastique correctement.
- Ⓜ Ce produit n'inclut aucune batterie. Si nécessaire, veuillez acheter séparément la batterie comme indiqué dans le manuel d'instructions.
- Ⓜ Ne peignez pas la lumière. Il peut mal fonctionner s'il est peint.
- Ⓜ Este producto es una maqueta de plástico. Por favor, use herramientas de modelismo para montarlo.
- Ⓜ Este producto no incluye herramientas de modelismo, pegamento o pintura. Si fuese necesario, por favor, cómprelas por separado.
- Ⓜ Lea las instrucciones cuidadosamente antes de empezar el montaje y siga los pasos de las instrucciones durante el proceso de montaje. Los modelistas más jóvenes deberían estar supervisados por adultos, que también deberían leer las instrucciones.
- Ⓜ Revise los números de las piezas antes de cortarlas de las matrices con alicates de corte. Para evitar perder o mezclar las piezas, no corte demasiadas a la vez. Por favor, deshágase de los residuos plásticos de forma adecuada.
- Ⓜ Este producto no incluye pilas. Si fuesen necesarias, por favor compre las pilas indicadas en el manual de instrucciones.
- Ⓜ No pinte las luces. Podrían funcionar incorrectamente al hacerlo.

⚠ 注意

- Ⓜ 本产品适用年龄为14岁以上。
- Ⓜ 本产品含有细小零件，为避免引起误吞危险，切勿让3岁以下幼童接触。
- Ⓜ 制作产品时必须远离儿童，避免小零件和工具对儿童造成伤害。
- Ⓜ 将零件取出后应立即丢弃包装袋，切勿将包装袋置于口鼻处或套在头部，以免引起窒息。
- Ⓜ 制作产品时需格外注意各类工具尖刃及零件锐角，以免造成伤害。
- Ⓜ 请勿将本产品置于明火或者高温源附近。

⚠ Внимание

- Ⓜ Данное изделие подходит для возраста от 14 лет.
- Ⓜ Содержит мелкие детали. Во избежание опасности случайного проглатывания, не подпускайте к изделию детей младше 3 лет.
- Ⓜ При изготовлении изделия, обязательно держитесь подальше от детей, чтобы мелкие детали и инструменты не причинили вреда детям.
- Ⓜ Упаковочный пакет следует выбросить сразу после извлечения деталей. Не разрешайте помещать упаковочный пакет детям в рот, нос или на голову, во избежание удушья.
- Ⓜ Соблюдайте правила безопасности при работе с режущими инструментами во избежание ранений и травм.
- Ⓜ Не размещайте данное изделие поблизости от открытого огня или источника высокой температуры.

⚠ Caution

- Ⓜ This product is for users aged above 14.
- Ⓜ This product contains small parts. Keep it out of reach of children under 3 years old to prevent the children from accidentally swallowing the parts.
- Ⓜ Keep children away from the assembly area to avoid any injury caused by small parts or tools.
- Ⓜ Please dispose the plastic bags properly after taking parts out. To avoid danger of suffocation, keep the plastic bags away from your mouth, nose or head.
- Ⓜ Please pay extra attention to the sharp tips and edges of tools and parts to avoid any injury.
- Ⓜ Keep this product away from fire or high temperature sources.

⚠ Vorsicht

- Ⓜ Dieses Modellbausatz ist für Benutzer unter 14 Jahren nicht geeignet.
- Ⓜ Dieses Produkt enthält Kleinteile, bewahren Sie es außerhalb der Reichweite von Kindern unter 3 Jahren auf, um zu verhindern, dass Kinder die Teile versehentlich verschlucken.
- Ⓜ Halten Sie Kinder vom Montagebereich fern, um Verletzungen durch Kleinteile oder Werkzeuge zu vermeiden.
- Ⓜ Bitte entsorgen Sie die Plastiktüten nach der Entnahme der Teile ordnungsgemäß. Um Erstickenungsgefahr zu vermeiden, halten Sie die Plastiktüten von Mund, Nase und Kopf fern.
- Ⓜ Achten Sie bitte besonders auf die scharfen Spitzen und Kanten von Werkzeugen und Teilen, um Verletzungen zu vermeiden.
- Ⓜ Halten Sie dieses Produkt von Feuer oder hohen Temperaturen fern.

⚠ 注意

- Ⓜ 本製品の対象年齢は14才以上です。
- Ⓜ 本製品には小さな部品が含まれています。誤って飲み込む危険を避けるため、3才未満の子供に触れさせないでください。
- Ⓜ 小さな部品や工具による子供へのケガを防ぐために、製品を組み立てる時は必ず子供を手元から離してください。
- Ⓜ 包装用の袋は部品を取り出した後すぐに廃棄してください。窒息しないように、袋を顔からかぶったり、鼻や口を覆ったりしないでください。
- Ⓜ 製品を組み立てる際には、ケガをしないように、各種工具や部品の鋭った尖角や鋭い刃に注意してください。
- Ⓜ 本製品を直火または高温の近くに置かないでください。

⚠ Attention

- Ⓜ Ce produit est destiné aux utilisateurs âgés de plus de 14.
- Ⓜ Ce produit contient de petites pièces. Gardez-les hors de portée des enfants de moins de 3 ans pour éviter que les enfants n'avalent accidentellement les pièces.
- Ⓜ Tenez les enfants éloignés de la zone de montage pour éviter toute blessure causée par de petites pièces ou des outils.
- Ⓜ Veuillez jeter les sacs en plastique correctement après avoir retiré les pièces. Pour éviter tout risque d'étouffement, gardez les sacs en plastique éloignés de votre bouche, de votre nez ou de votre tête.
- Ⓜ Veuillez prêter une attention particulière aux pointes et bords tranchants des outils et des pièces pour éviter toute blessure.
- Ⓜ Gardez ce produit à l'écart du feu ou des sources de haute température.



⚠ Cuidado

ⓘ Este producto es para personas mayores de 14 años.
ⓘ Este producto contiene partes pequeñas. Mantener alejado de niños menores de 3 años para evitar que accidentalmente puedan tragarse las piezas.

ⓘ Mantener a los niños lejos del área de montaje para evitar cualquier herida causada por piezas pequeñas o herramientas.
ⓘ Tire las bolsas de plástico correctamente después de extraer las piezas. Para evitar peligro de asfixia mantenga las bolsas de plástico lejos de la boca, nariz o cabeza.

ⓘ Preste especial atención a puntas y bordes de herramientas afiladas para evitar cualquier daño.
ⓘ Mantenga este producto lejos del fuego o de lugares con altas temperaturas.

零件剪取方式

Injection gate and sprue puller cleaning

部品の切り取り方法

Способ вырезания деталей

Entfernen von Teilen aus Angüssen

Retrait de pièces des tiges de coulée

Quitar Piezas de las Matrices

- ⓘ 首先使用剪钳剪下零件，之后使用笔刀或美工刀将零件上的残余水口或拉钩切除。
- ⓘ Remove parts with side cutters and then clean the injection gate residual material or sprue pullers with a hobby knife or utility knife.
- ⓘ まずはモデル専用ニッパーで部品を切り取り、その後カッターやデザインナイフで部品に付いているゲート口や余計な突起をきれいに切り取ってください。
- ⓘ Сначала используйте кусачки, чтобы отрезать деталь с литника, затем используйте канцеровый модельный нож, чтобы отрезать остаточные детали и крепления.
- ⓘ Entfernen Sie die Teile mit einem Seitenschneider und säubern Sie dann die Angussreste oder Angussabzieher mit einem Hobbymesser.
- ⓘ Retirez les pièces avec une pince coupante latérale, puis nettoyez le matériau résiduel de la porte d'injection ou les extracteurs avec un couteau passe-temps.
- ⓘ Quite las piezas con alicates de corte lateral y limpie los puntos de unión con un cúter de modelismo.

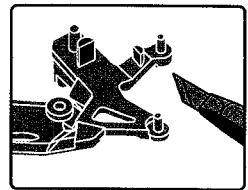
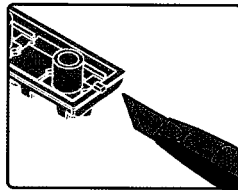
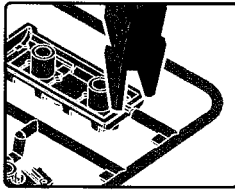

水貼使用说明

Decal Application

水転写デカールの貼り方

Инструкция использования водных наклеек

Anbringen der Naßschiebebilder

Application d'autocollants

Aplicación de Calcas

- | | |
|-----------------------------------------------------------------------------------------------------------------------------------------------------------------------------------------------------------------------------------------------------------------------------------------------------------------------------------------------------------------------------------------------------------------------------------------------------------------------------------------------------------------------------------------------------------------|--------------------------------------------------------------------------------------------------------------------------------------------------------------------------------------------------------------------------------------------------------------------------------------------------------------------------------------------------------------------------------------------------------------------------------------------------------------------------------------------------------------------------------------------------------------|
| <ol style="list-style-type: none">① Cut off a decal from the decal sheet.② Dip the decal in tepid water for about 10 seconds and place it on a clean cloth.③ Hold the backing sheet edge and slide the decal onto the model.④ Move decal into position with a wet finger.⑤ Press decal gently down with a soft cloth until excess water and air bubbles are gone. | <ol style="list-style-type: none">① 将水贴从薄片上剪下。② 将水贴在温水中浸泡10秒钟，然后将其放在干净的布上。③ 夹住底纸的边缘，将水贴滑动到模型上。④ 用蘸水的手指将湿润的水贴移动到合适的位置。⑤ 用软布轻轻按压水贴，直到将多余的水和水泡压出为止。 |
| <ol style="list-style-type: none">① Schneiden Sie ein Bild aus dem Aufkleberbogen aus.② Tauchen Sie den Aufkleber etwa 10 Sekunden lang in lauwarms Wasser und legen Sie ihn auf ein sauberes Tuch.③ Halten Sie die Kante des Trägerblatts fest und schieben Sie das Abziehbild auf das Modell.④ Bewegen Sie das Abziehbild mit einem feuchten Finger in die richtige Position.⑤ Drücken Sie das Abziehbild vorsichtig mit einem weichen Tuch an, bis überschüssiges Wasser und Luftblasen verschwunden sind. | <ol style="list-style-type: none">① 貼りたい部分をハサミで切り抜きます。② ぬるま湯に10秒ほど浸してから、清潔なタオルなどの布に置きます。③ 台紙の端をピンセットで持ち、貼るところにデカールをスライドさせてモデルに移します。④ 指に少し水をつけて、デカールを正しい位置に調整します。⑤ 柔らかい布でデカール内側の気泡を押し出しながら、押し付けるようにして水分を取り除きます。 |
| <ol style="list-style-type: none">① Découpez un autocollant de la feuille d'autocollants.② Trempez-le dans de l'eau tiède pendant environ 10 secondes et placez-le sur un chiffon propre.③ Tenez le bord de la feuille de support et faites glisser l'autocollant sur le modèle.④ Déplacez l'autocollant en position avec un doigt mouillé.⑤ Appuyez doucement sur l'autocollant avec un chiffon doux jusqu'à ce que l'excès d'eau et les bulles d'air disparaissent. | <ol style="list-style-type: none">① Вырежьте нужный фрагмент.② Поместите наклейку в теплую воду на 10 секунд, затем положите на чистую и сухую ткань.③ Зажав край бумажной основы, аккуратно водными скользкими движениями поместите водную наклейку на поверхность модели.④ Смоченными в воде пальцами поместите влажную наклейку на соответствующее место.⑤ Используя мягкую ткань, аккуратно прижмите и разгладьте водную наклейку от центра к краям, удаляя возможные пузырьки воздуха и остатки воды. |
| <ol style="list-style-type: none">① Corte una calca de la hoja de calcas.② Sumerja la calca en agua tibia durante 10 segundos y colóquela en un trapo limpio.③ Sujete el borde del soporte de la hoja y deslice la calca sobre el modelo.④ Mueva la calca a su posición con un dedo umedecido.⑤ Presione la calca con delicadeza con un trapo suave hasta que el exceso de agua y las burbujas hayan desaparecido. | <ol style="list-style-type: none">① Corte una calca de la hoja de calcas.② Sumerja la calca en agua tibia durante 10 segundos y colóquela en un trapo limpio.③ Sujete el borde del soporte de la hoja y deslice la calca sobre el modelo.④ Mueva la calca a su posición con un dedo umedecido.⑤ Presione la calca con delicadeza con un trapo suave hasta que el exceso de agua y las burbujas hayan desaparecido. |

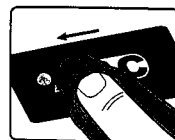
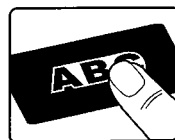
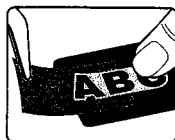
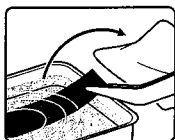
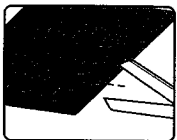

使用工具

Tools recommended

使用する工具

Рекомендуемые инструменты

Empfohlene Werkzeuge

Outils recommandés

Herramientas recomendadas

剪钳

Side cutters

ニッパー

Кусачки

Seitenschneider

Pincès coupantes latérales

Alicates de corte lateral

BASIC HOBBY TOOL SET
MTS-003

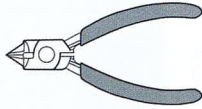

笔刀

Hobby knife

デザイナーナイフ

Цанговый модельный нож

Bastelmesser

Couteau passe-temps

Cuchilla de modelismo

BASIC HOBBY TOOL SET
MTS-003



镊子

Tweezers

ピンセット

Пинцет

Pinzette

Pince à épiler

Pinzas

BASIC HOBBY TOOL SET
MTS-003



美工刀

Utility knife

カッターナイフ

Технический нож

Cuttermesser

Couteau tout usage

Cuchillo para uso general



模型专用剪钳推荐

Recommended hobby side cutters

お勤めのモデル専用ニッパー

Специализированные кусачки-бокорезы для работы над моделью

Empfohlene Hobby-Seitenschneider

Pincès coupantes latérales de loisir recommandées

Alicate de corte lateral recomendado

■ 推荐使用MENG与DSPIAE合作设计生产的模型工具产品。

■ We recommend to use the modeling tool presented by MENG and DSPIAE together.

■ MENGとDSPIAEが協力して開発したモデル専用ツールのご使用をお勧めします。

■ Рекомендуется использовать специальные модельные инструменты, разработанные и произведенные компанией MENG в сотрудничестве с DSPIAE.

■ Wir empfehlen, das von MENG und DSPIAE vorgestellte Modellierwerkzeug gemeinsam zu verwenden.

■ Nous recommandons d'utiliser l'outil de modélisation présenté par MENG et DSPIAE.

■ Recomendamos usar la herramienta de modelismo presentada conjuntamente por MENG y DSPIAE.

■ 剪钳采用单刃设计，刃口锋利刚硬，剪切面工整光滑、无挤断现象，手柄握持稳固，使用手感舒适。

■ This single-edged side cutter features a sharp and hard blade. The cut surface on parts is neat and smooth. The ergonomically designed handle has an increased grip surface and offers improved cutting experience.

■ 鋭く硬い刃を持った片刃のニッパーで、部品の切断面が滑らかになります。また、持ち手がしつかりしていて、使い心地が良いです。

■ Лезвие кусачек изготовлено из прочного сплава и имеет одностороннюю заточку, с аккуратной и гладкой режущей поверхностью, позволяющую срезать пластик, не оставляя зазубрин. Ручка удобной формы обеспечивает стабильное удержание инструмента и комфортную работу.

■ Dieser einschneidige Seitenschneider verfügt über eine scharfe und harte Klinge. Die Schnittfläche an Teilen ist sauber und glatt. Der ergonomisch geformte Griff hat eine erhöhte Grifffläche und bietet ein verbessertes Schneideerlebnis.

■ Ce couteau latéral est doté d'une lame tranchante et dure. La surface de coupe est nette et lisse. La poignée ergonomique a une surface de préhension accrue et offre une expérience de coupe améliorée.

■ El alicate de corte lateral tiene una hoja dura y afilada. El corte sobre la superficie de las piezas es limpio y liso. El mango de diseño ergonómico tiene una gran superficie de agarre y ofrece una experiencia de corte mejorada.

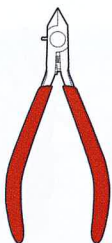

限位螺栓调节器

Limit regulator

調整用ドライバー

Регулятор предела

Begrenzungsregler

Régulateur de limite

Regulador de Limite



刃口保护皮套

Side cutters pouch

保護カバー

Чехол для кусачек из

натуральной кожи

Seitenschneider-Tasche

Pochette pour couteaux

latéraux

Bolsa protectora de

cortadores laterales



限位螺栓调节器

Limit regulator

調整用ドライバー

Регулятор предела

Begrenzungsregler

Régulateur de limite

Regulador de Limite



刃口保护皮套

Side cutters pouch

保護カバー

Чехол для кусачек из

натуральной кожи

Seitenschneider-Tasche

Pochette pour couteaux

latéraux

Bolsa protectora de

cortadores laterales

MTS-022

进阶版

Intermediate edition

上級

Основной вариант

Einfache Ausführung

Édition intermédiaire

Edición intermedia

MTS-026

高级版

Advanced edition

高級

Продвинутый вариант

Mittlere Ausführung

Édition avancée

Edición avanzada

MTS-039

精密版

Precision edition

精密

Высокоточный вариант

Profi Ausführung

Édition de précision

Edición de precisión

1

HEAD ASSEMBLY

头部组装

頭部の組み立て

本步骤需要以下板件/零件。
For this step, please use the following sprues/parts.
このステップでは、以下のランナーパーツを使用します。

不使用零件
Parts not needed
使用しないパーツ



F1 Parts

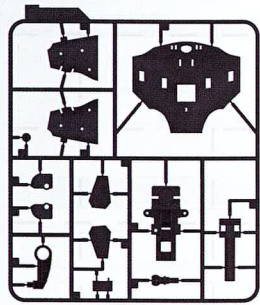

H2 Parts

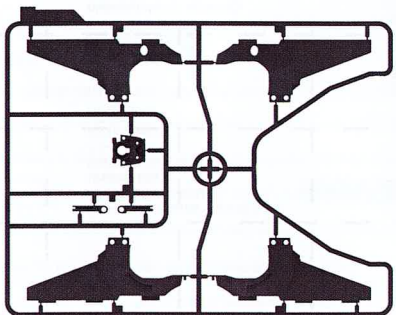

V Parts

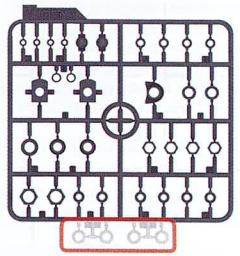

H3 Parts

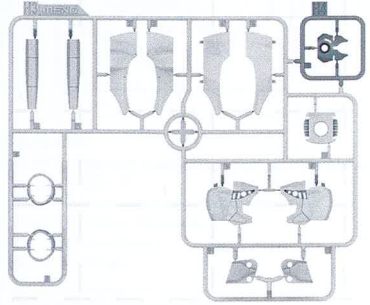

H4 Parts

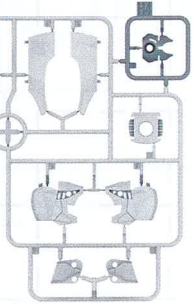

H5 Parts

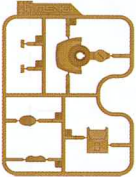

T1 Parts



T2 Parts



电路A
Circuit A
回路A



L1 Parts

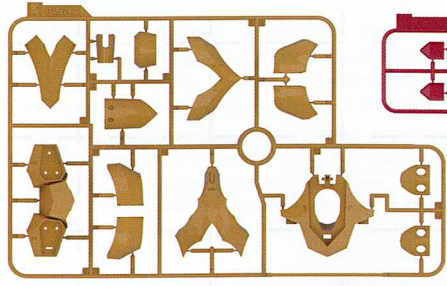

H6 Parts

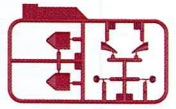

Q2 Parts

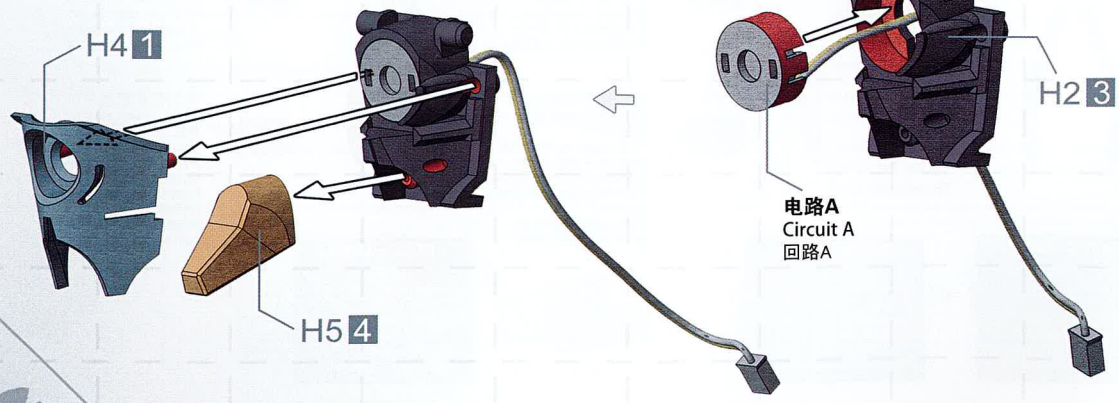
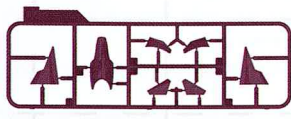

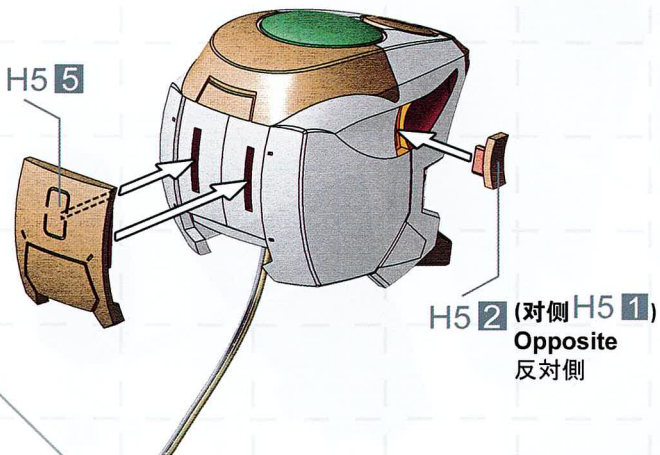
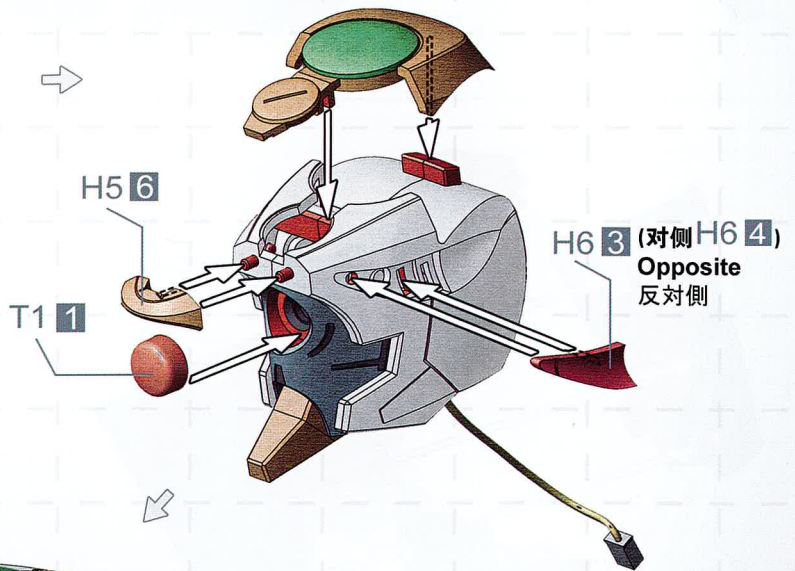
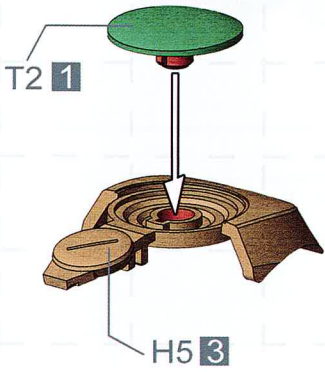
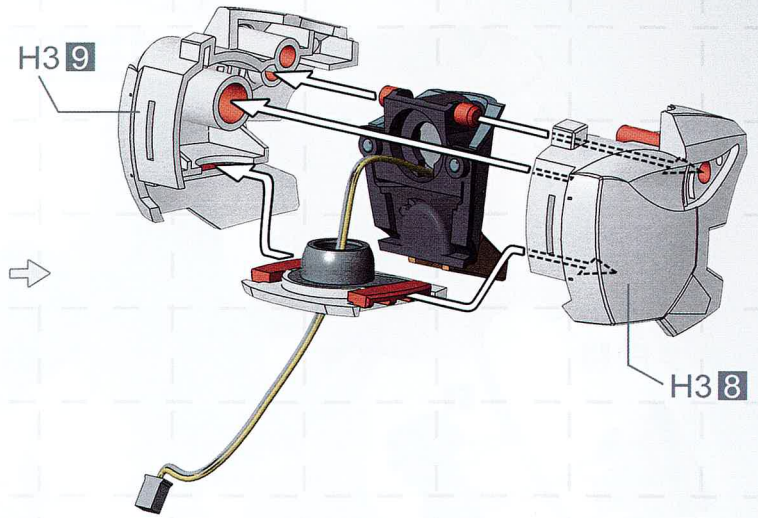
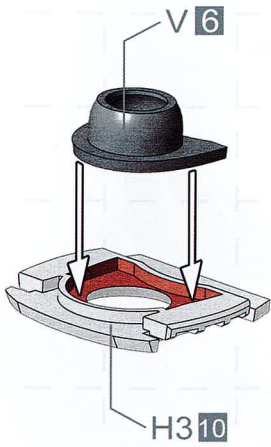

1 2 3

☐ 依照数字顺序组合
☐ Attaching in numerical order.
☐ 順番通りに組み立ててください。

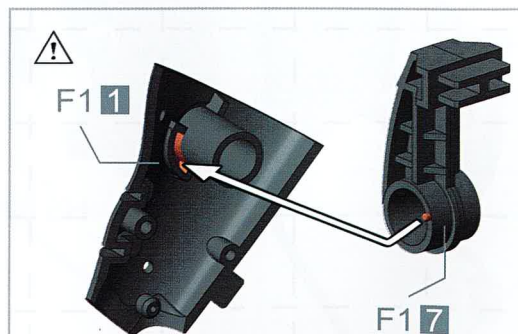
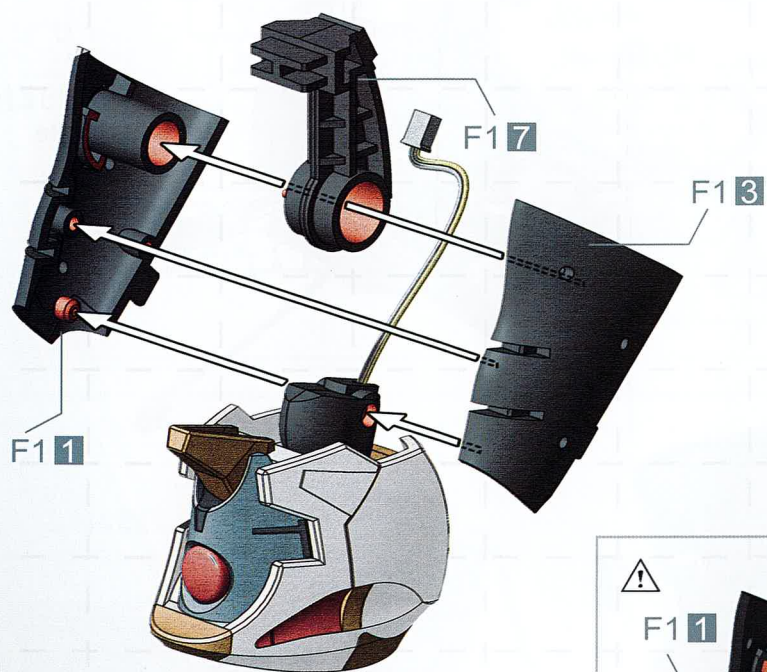
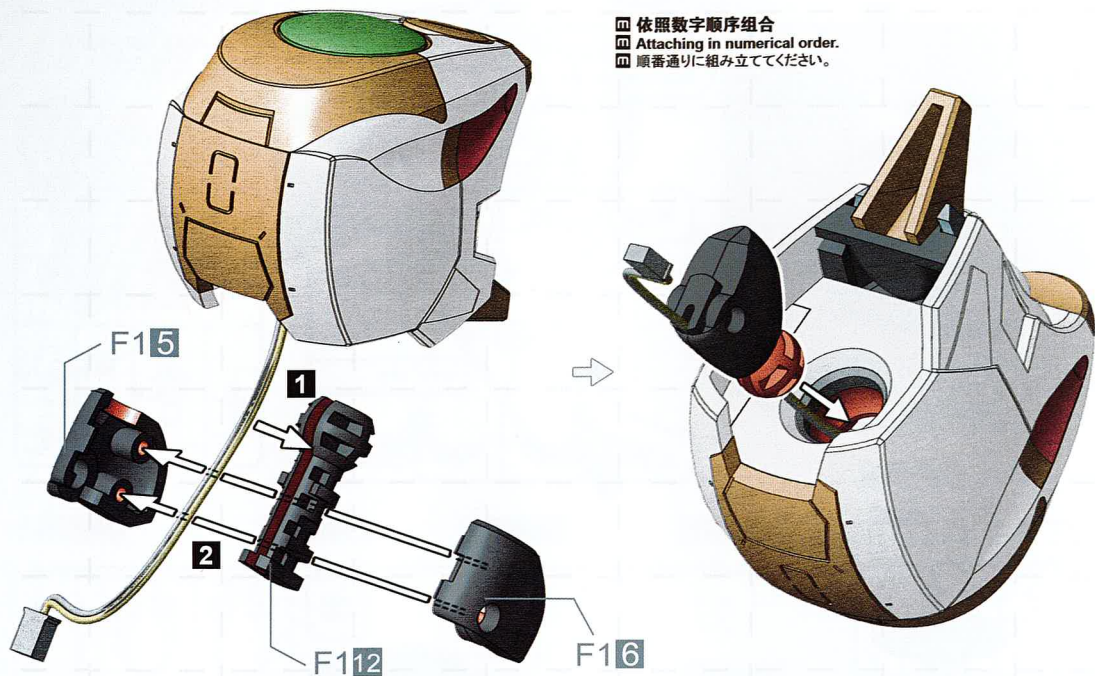

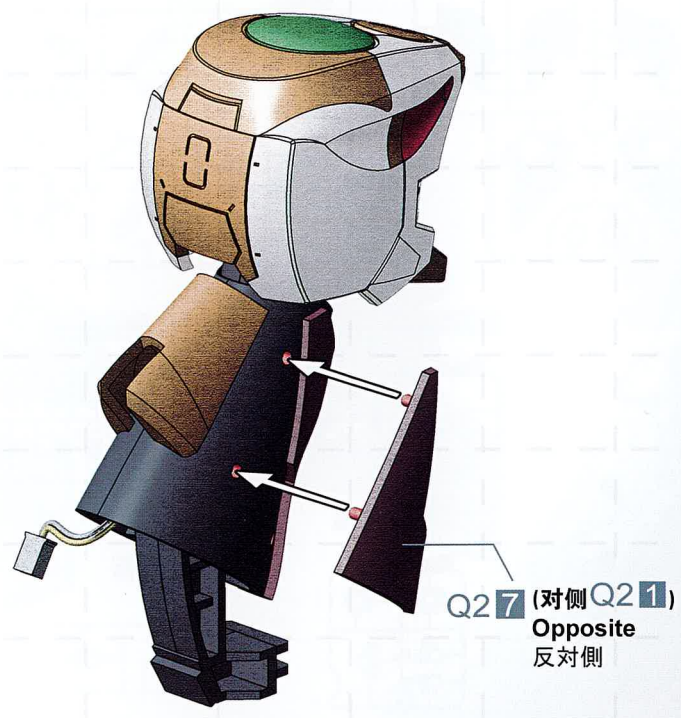
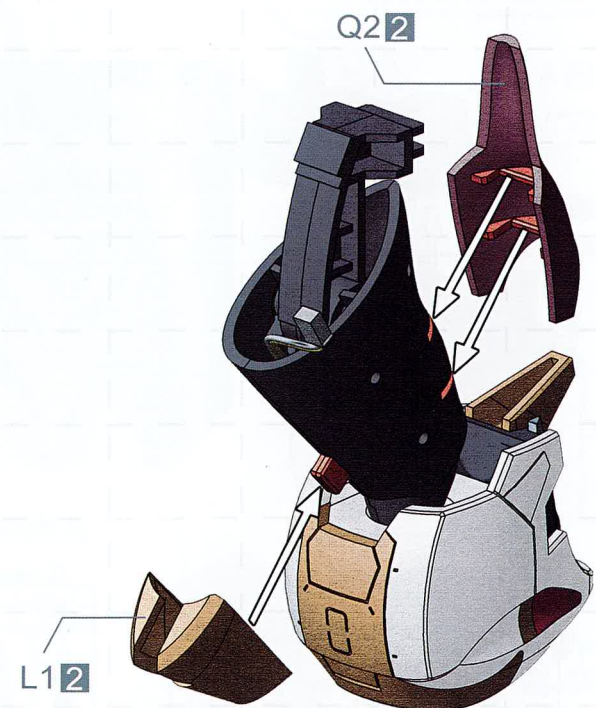

躯干组装

胴体の組み立て

本步骤需要以下板件/零件。
For this step, please use the following sprues/parts.
このステップでは、以下のランナー/パーツを使用します。

⚠️ 不使用零件
Parts not needed
使用しないパーツ



F1 Parts

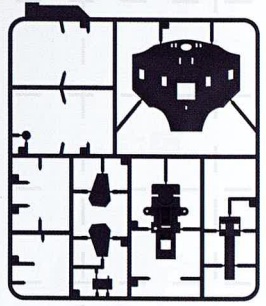

H3 Parts

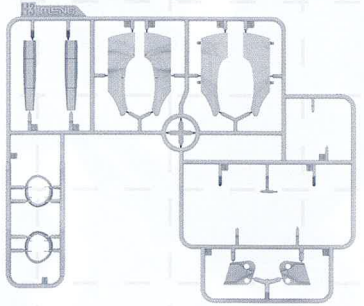

A Parts

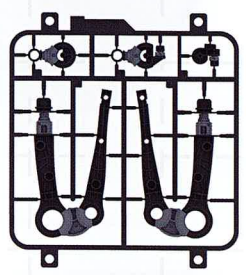

S1 Parts

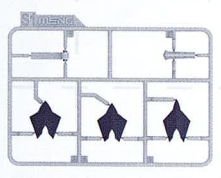

N1 Parts

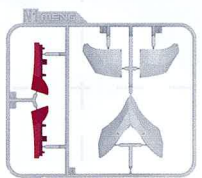

V Parts

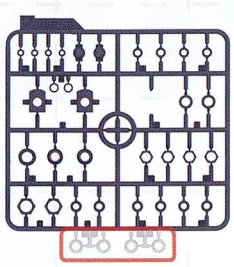

G1 Parts

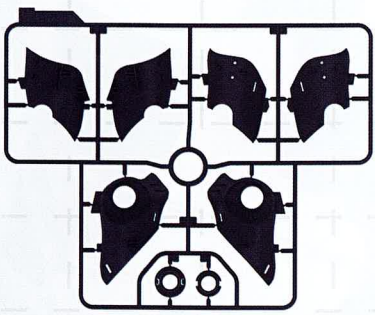

L1 Parts

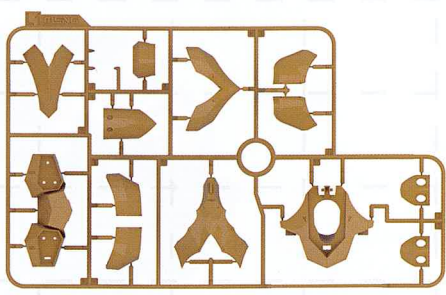

H1 Parts



电路B
Circuit B
回路B

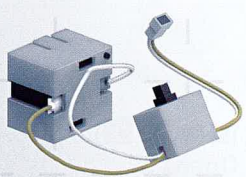

Q2 Parts

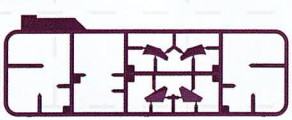

P1 Parts

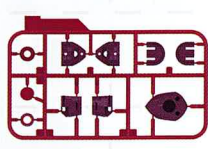

H7 Parts



K2 Parts x2

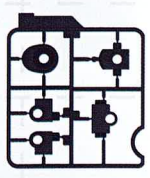

R1 Parts

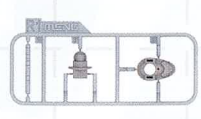

螺丝 x4
Screw
ネジ



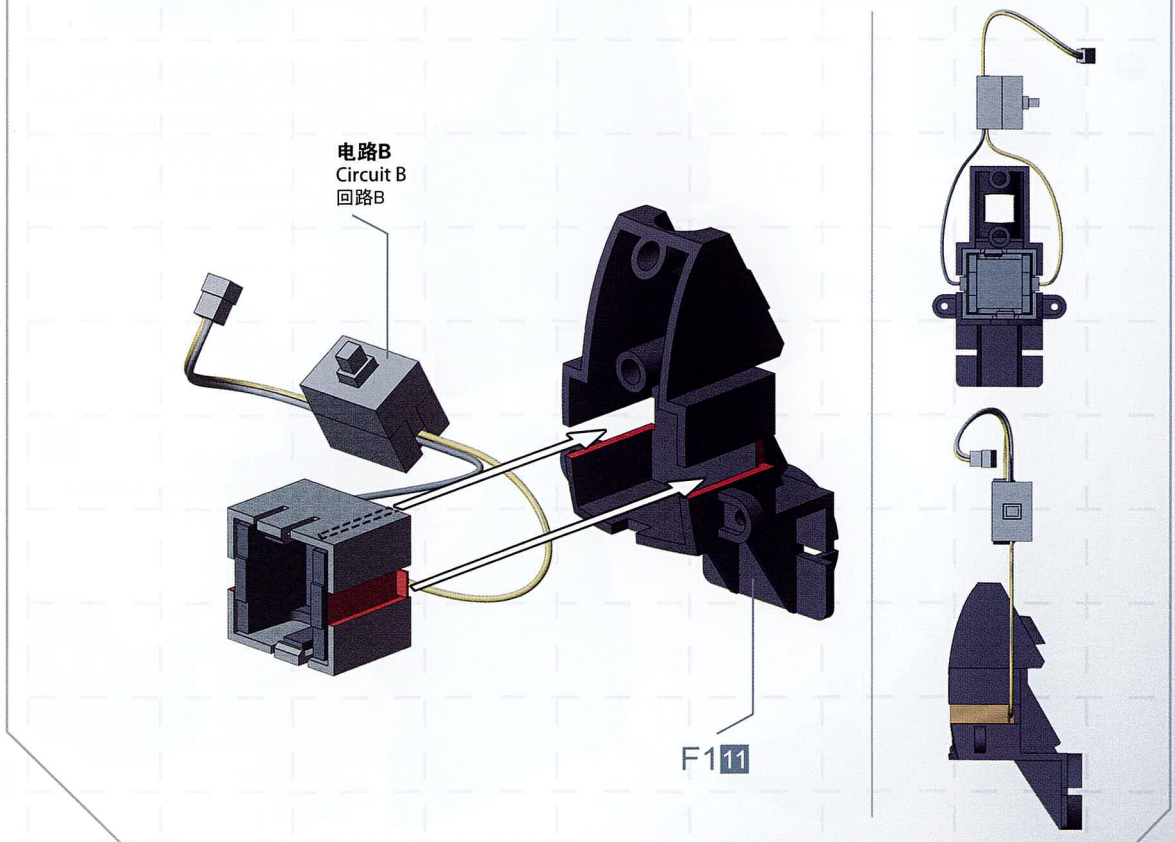
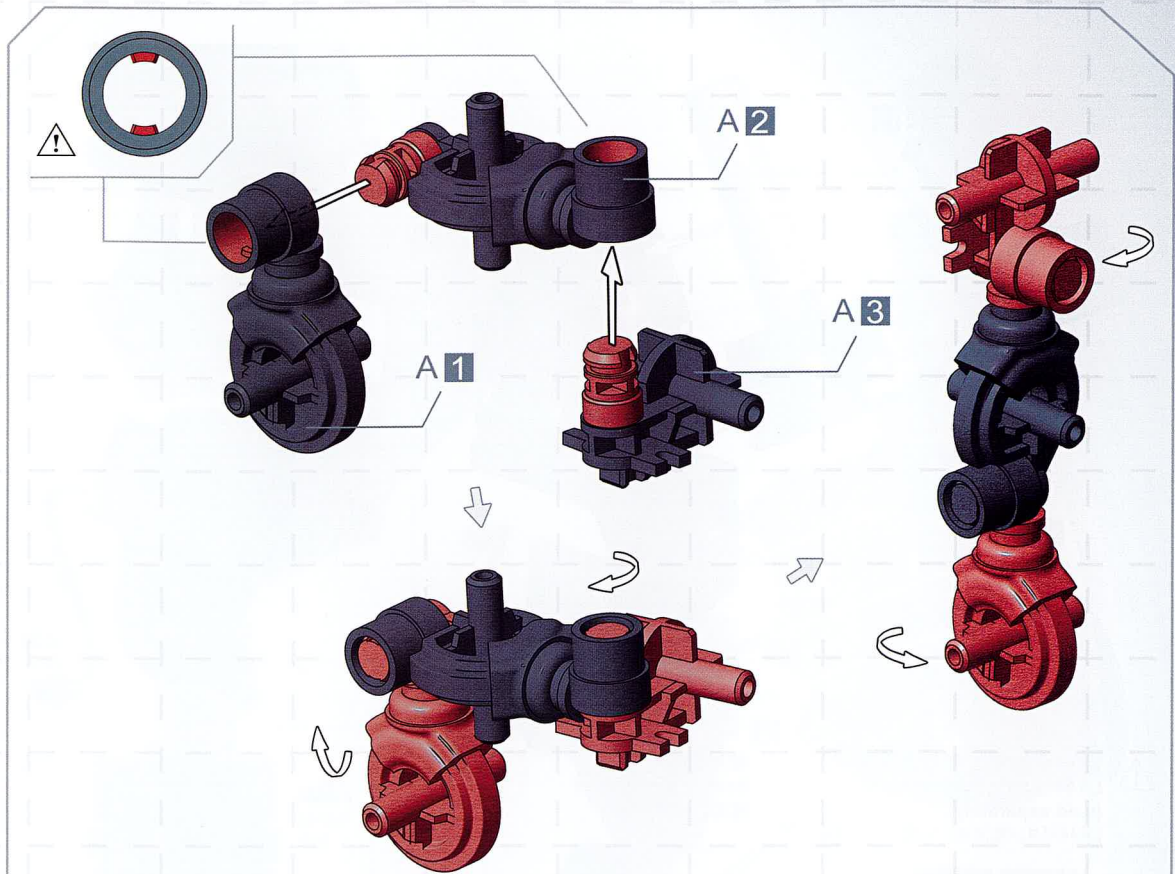

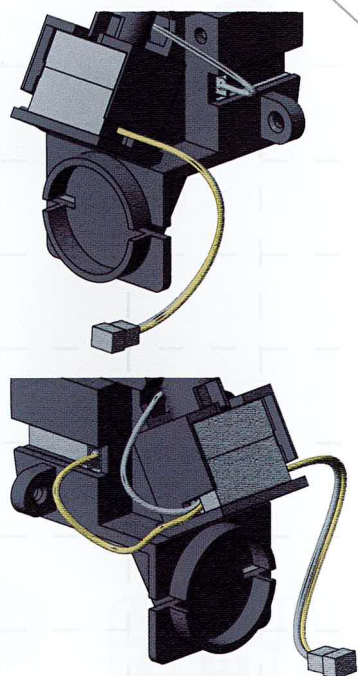
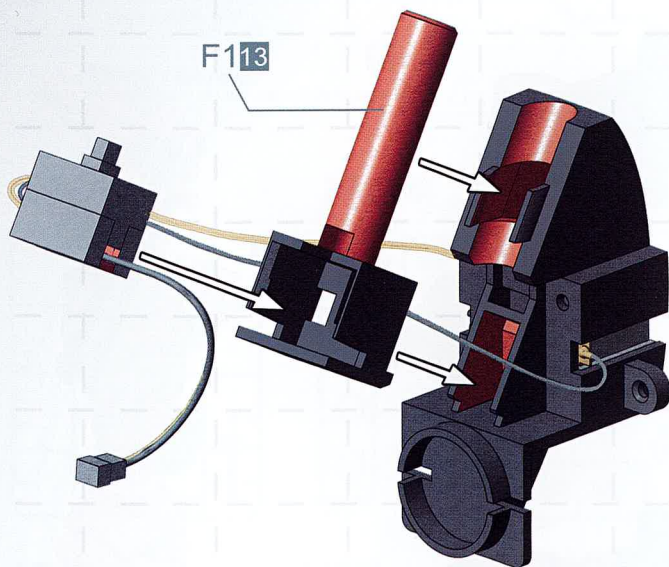

⚠ LR44纽扣电池 两枚(需另购)。
LR44 button cell battery*2
(sold separately).
LR44ボタン電池X2(別売り)。

电池安装
Battery installation
電池の取り付け

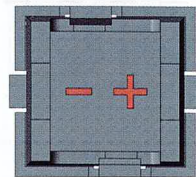

按电池盒正负极标记放置电池。
Install the batteries with the + and -
terminals in correct directions
marked on the battery holder.
電池ボックスの指示に従って、電池のプ
ラス、マイナス(+極・-極)を正しく装着
してください。

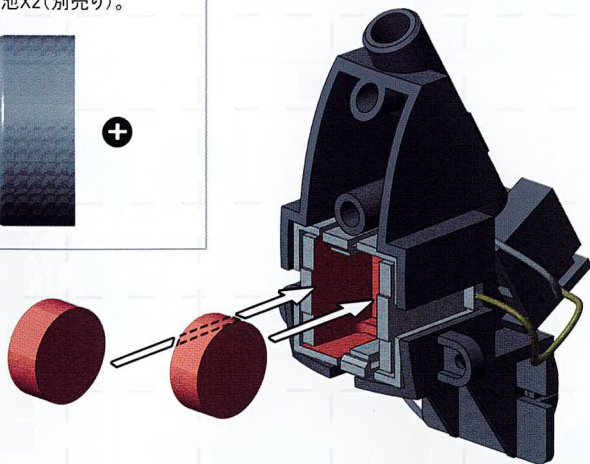
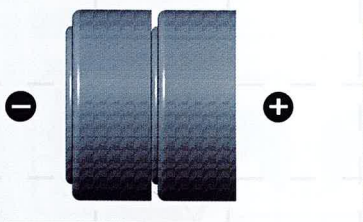

电池拆卸, 借助工具。
Use a tool to remove the batteries.
工具で電池を取り外します。

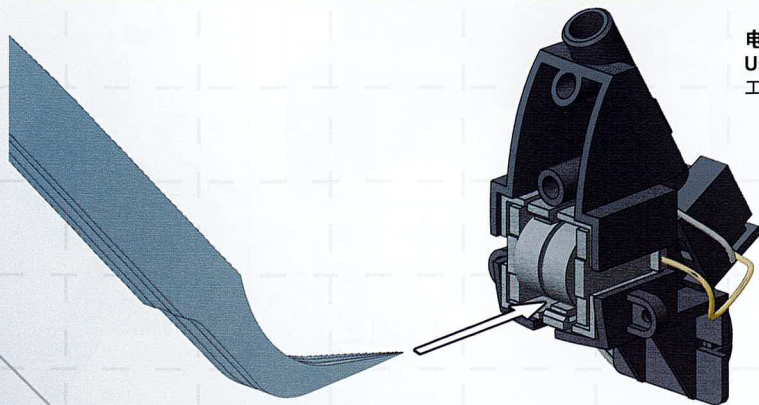

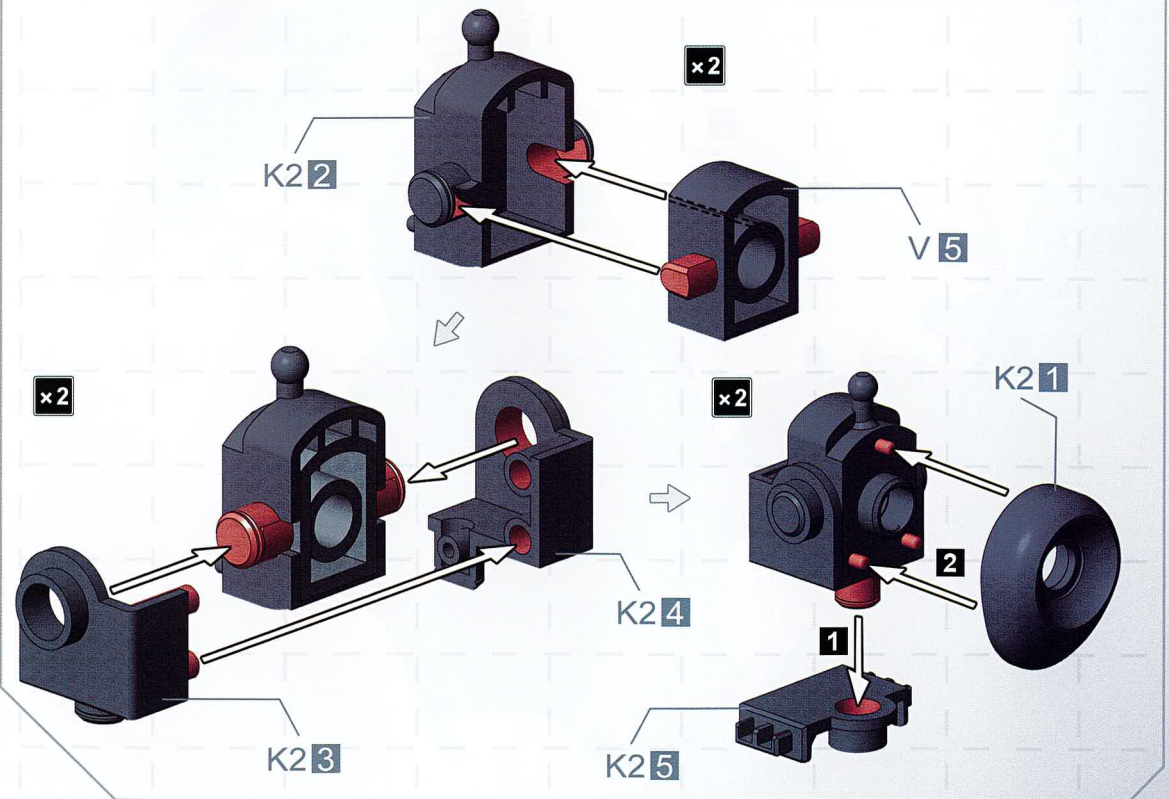
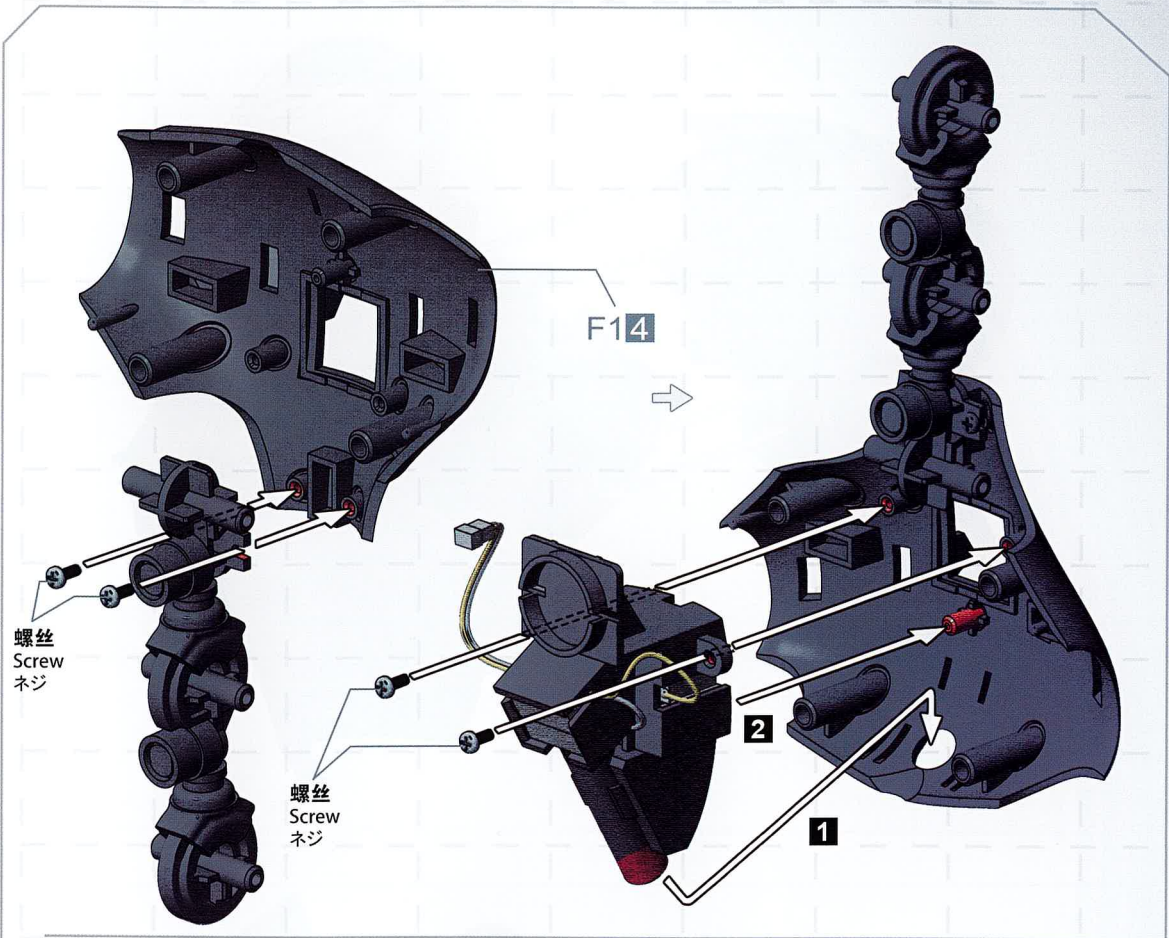

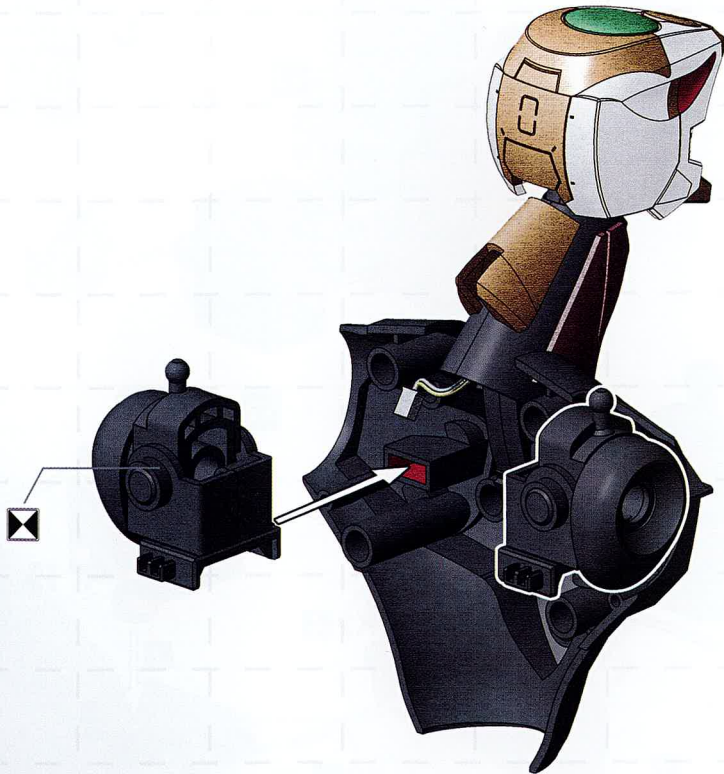
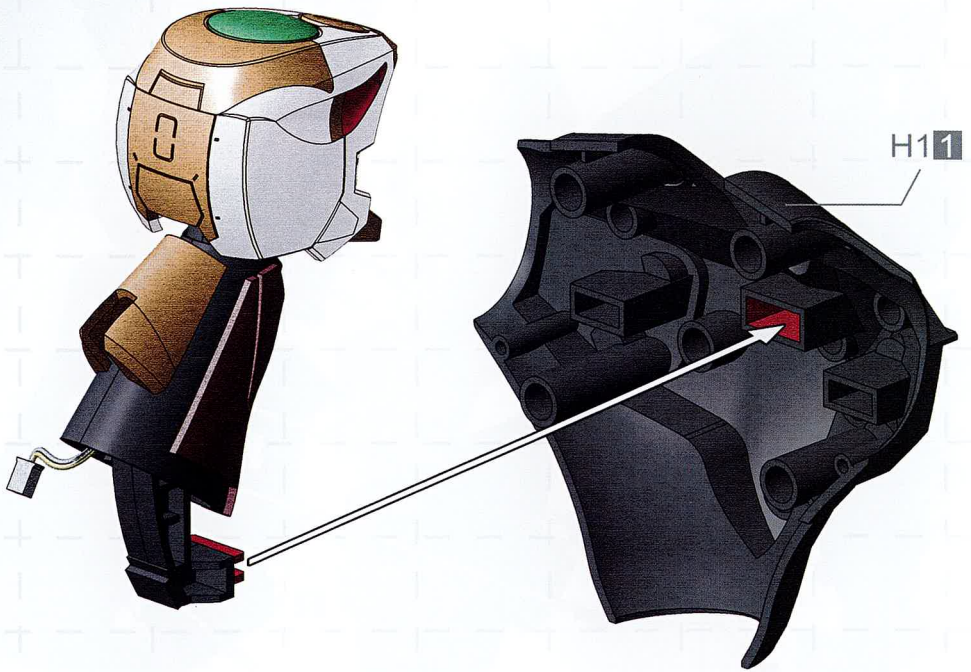

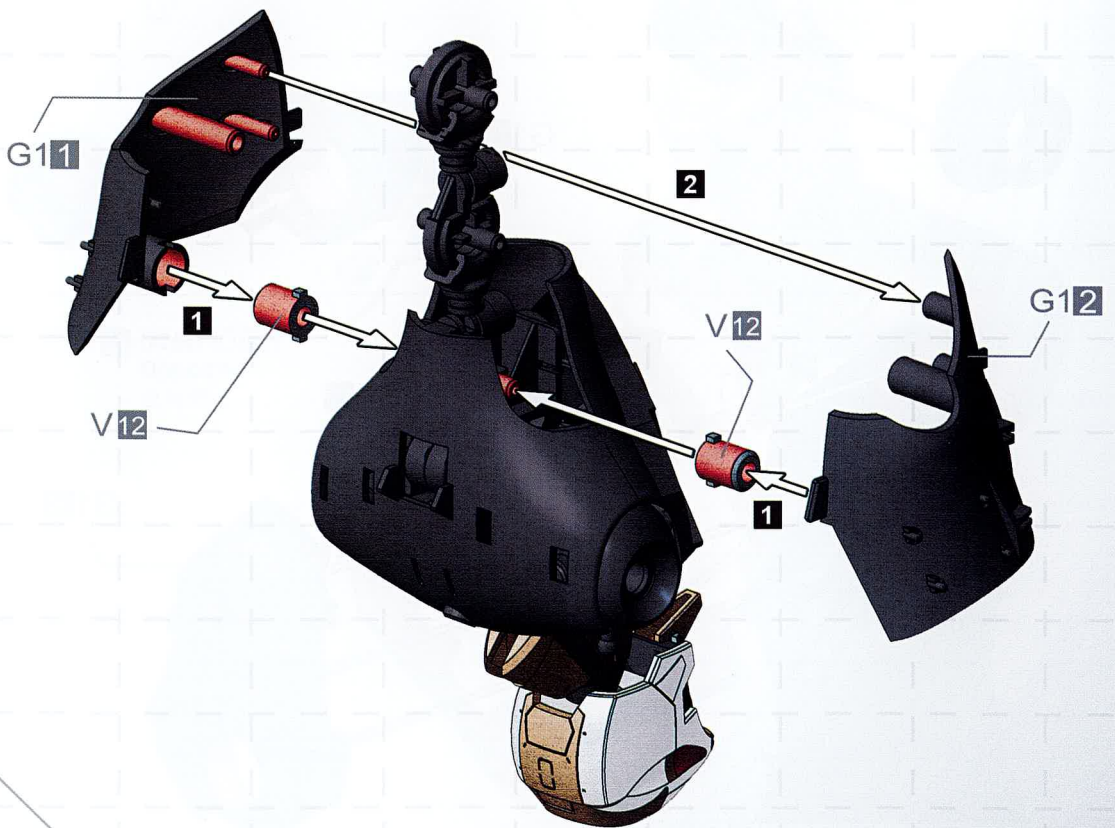
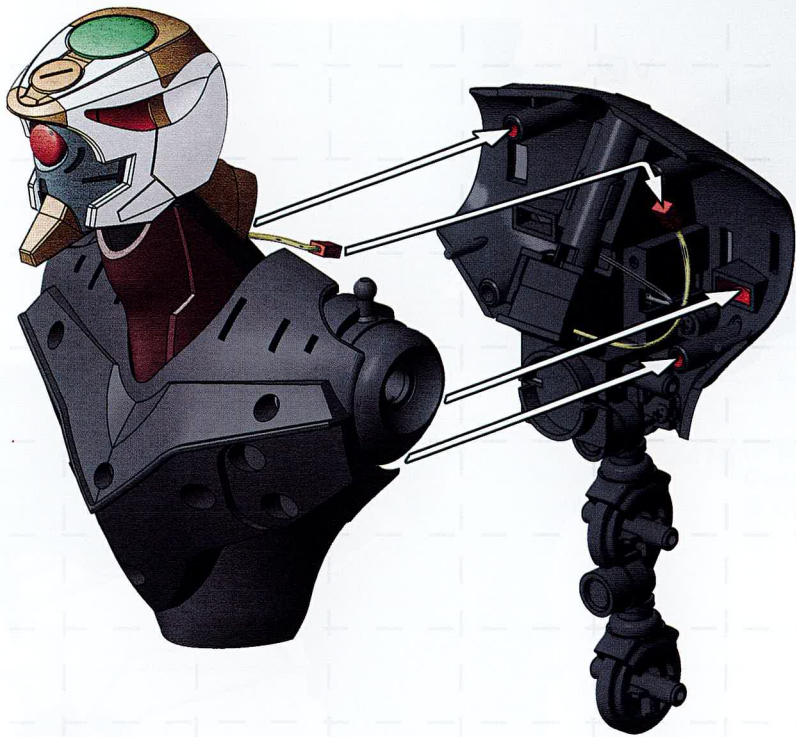

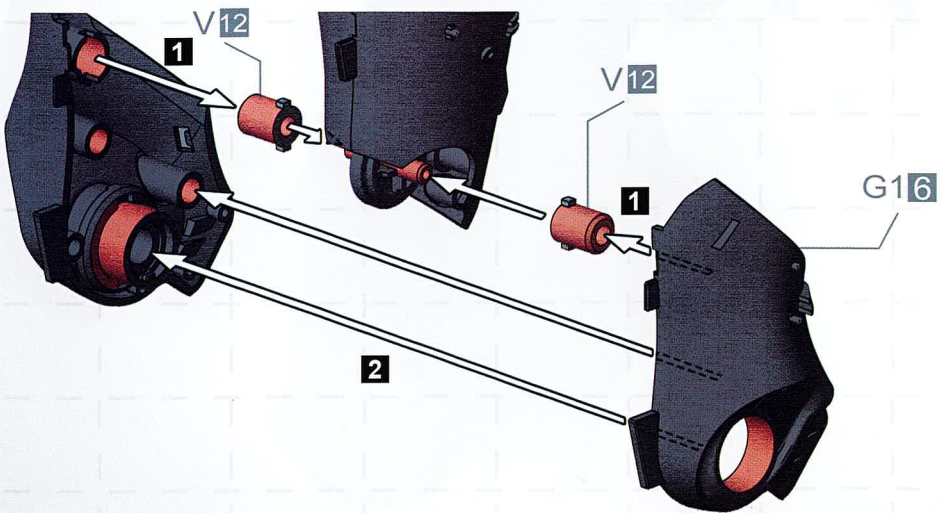
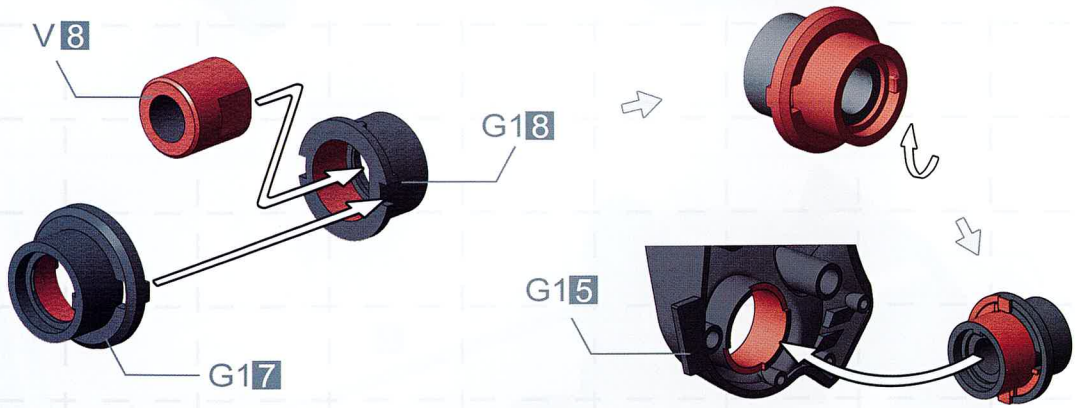
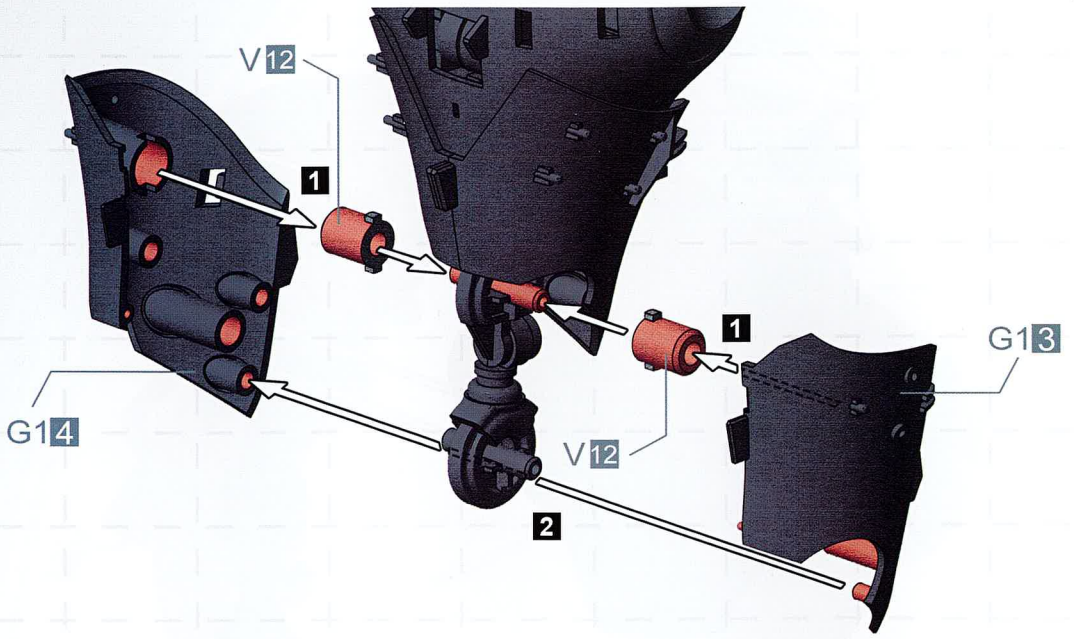



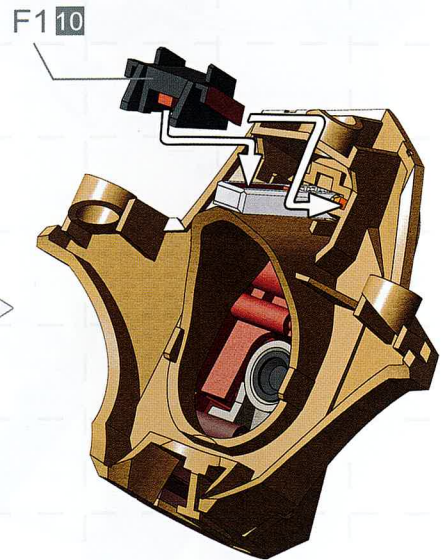
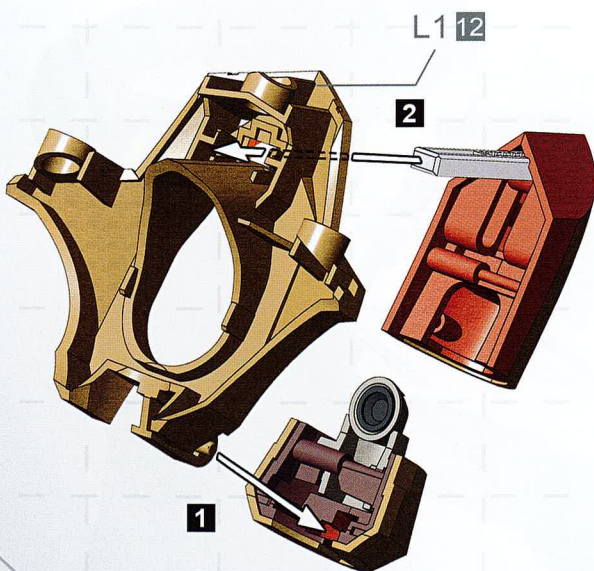
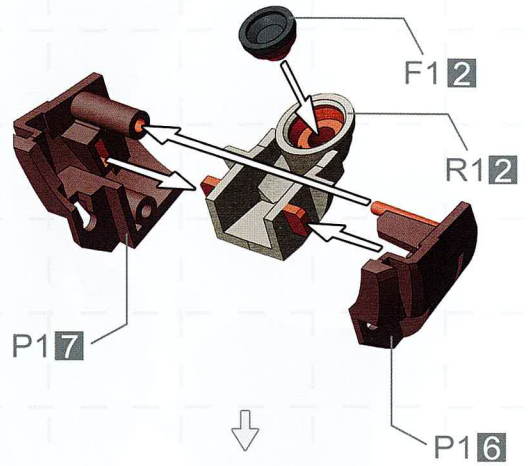
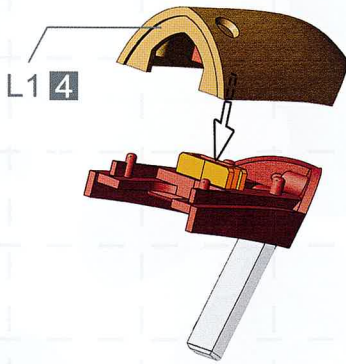
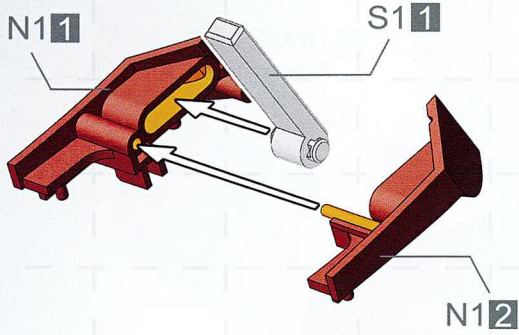

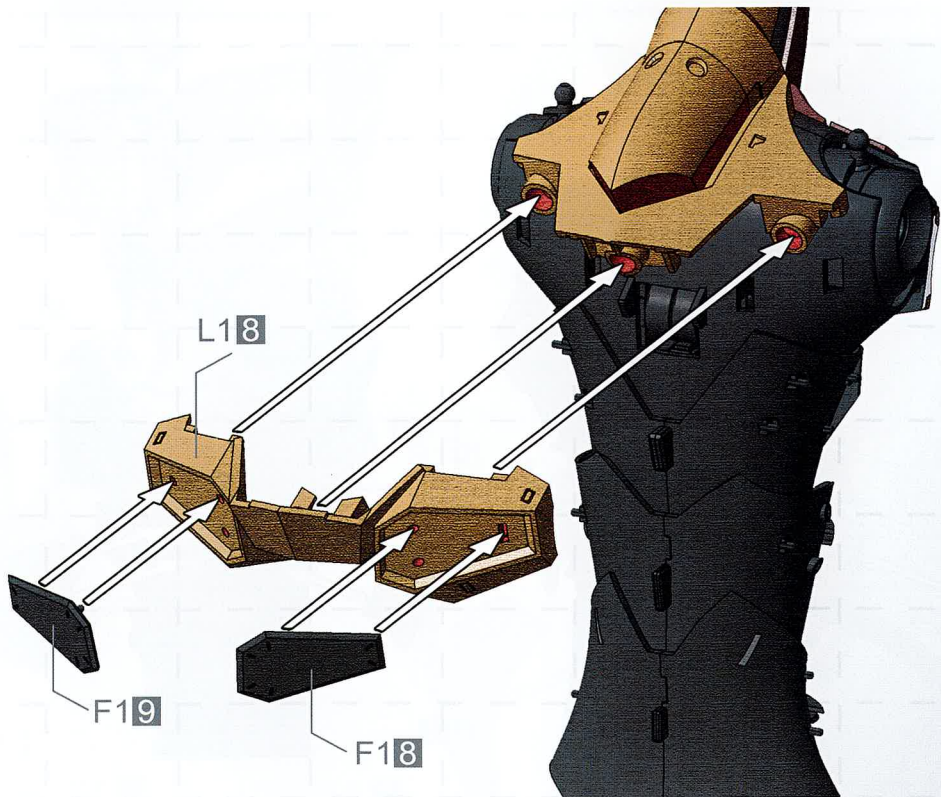
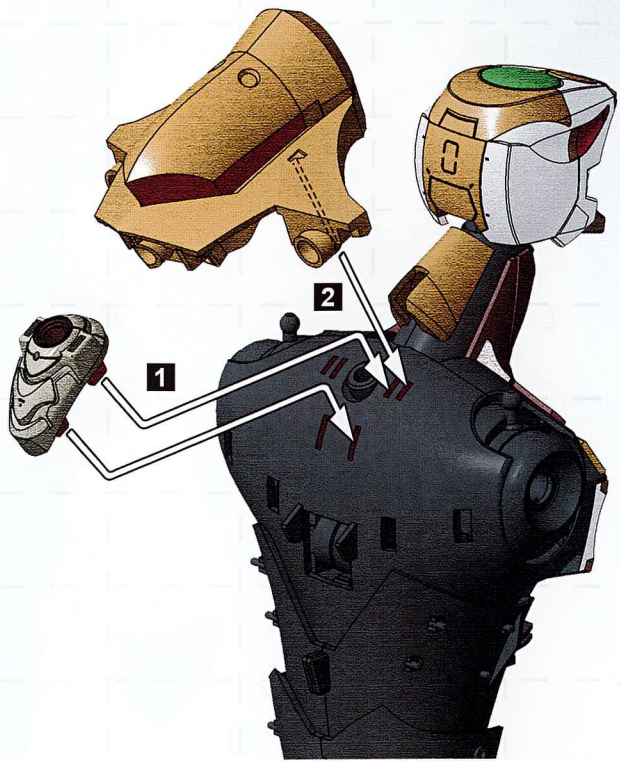
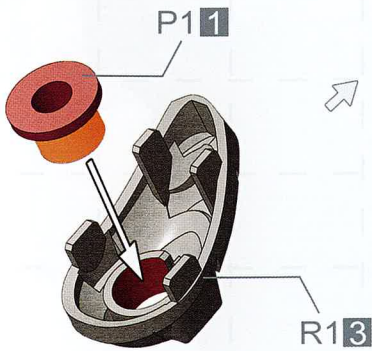

×2

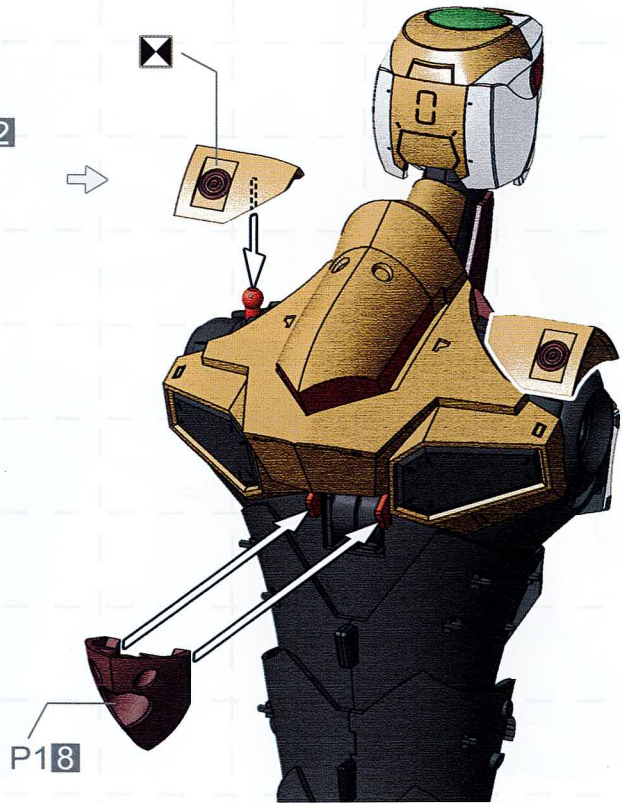
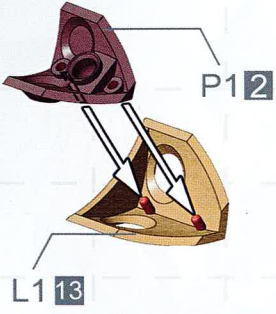

L115



L119

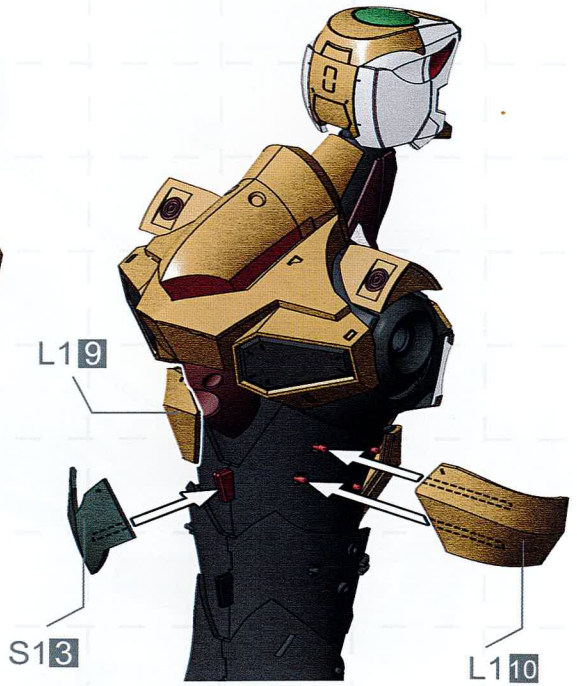

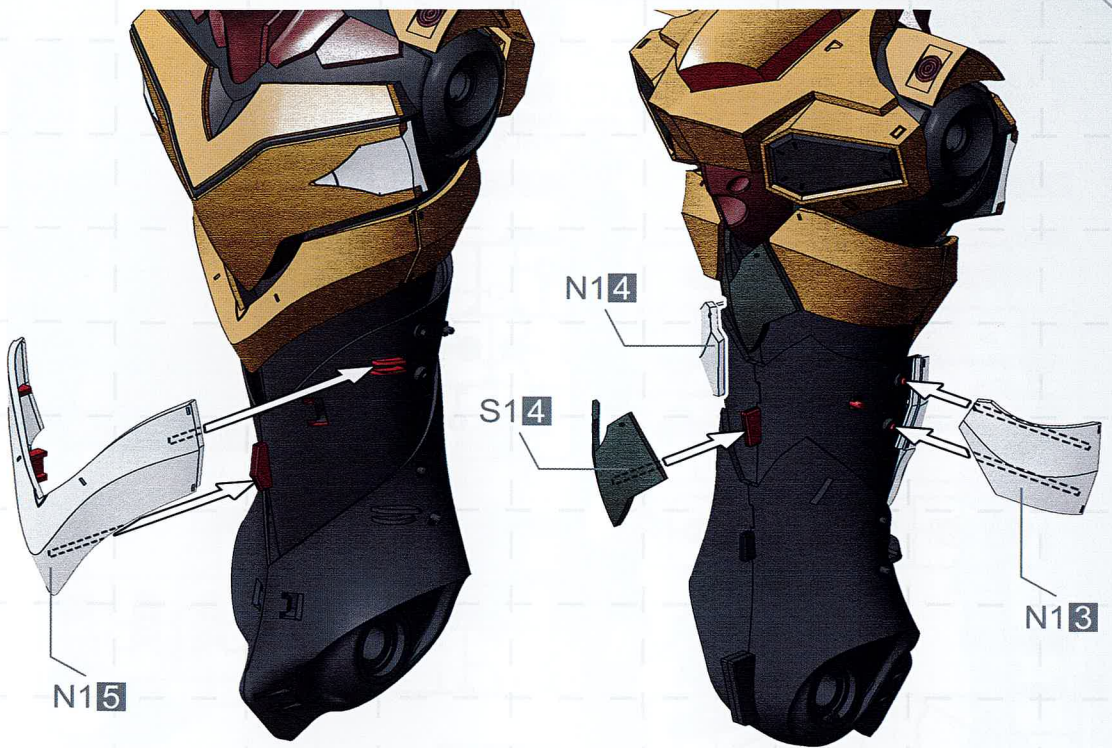

3

LEG ASSEMBLY

腿部组装

足の組み立て

本步骤需要以下板件/零件。
For this step, please use the following sprues/parts.
このステップでは、以下のランナー/パーツを使用します。



不使用零件
Parts not needed
使用しないパーツ

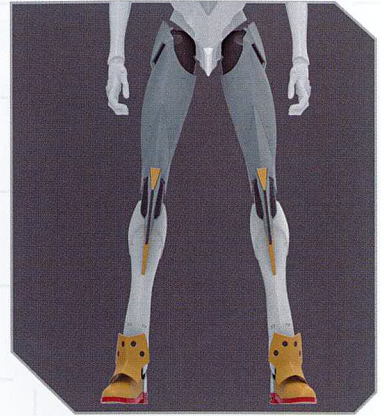

C&D Parts

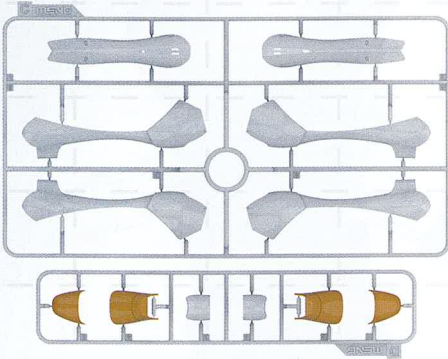

K1 Parts X2

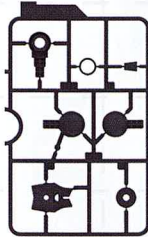

P1 Parts

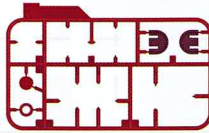

Q1 Parts

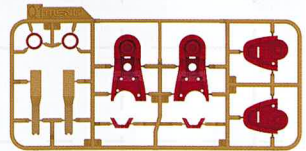

B Parts

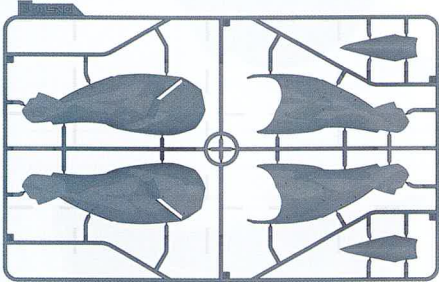

J1 Parts X2

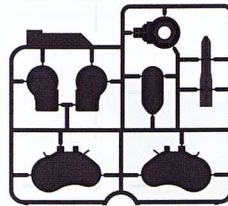

N2 Parts

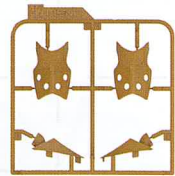

A Parts

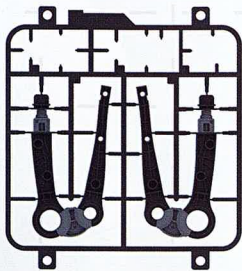

V Parts

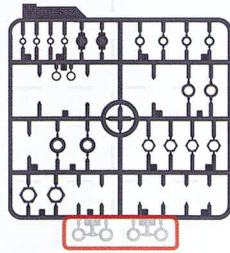

E1&E2 Parts

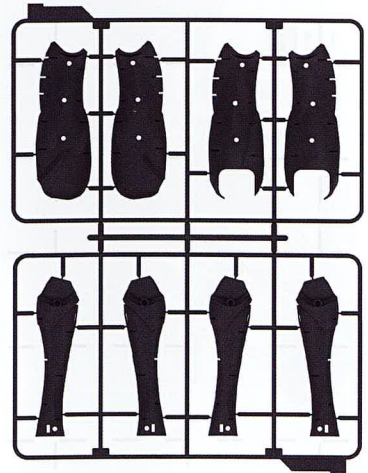

U2 Parts

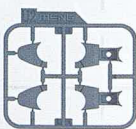

G5 Parts

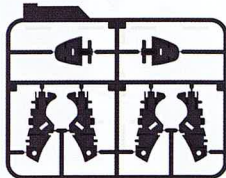

左腿
Left leg
左足

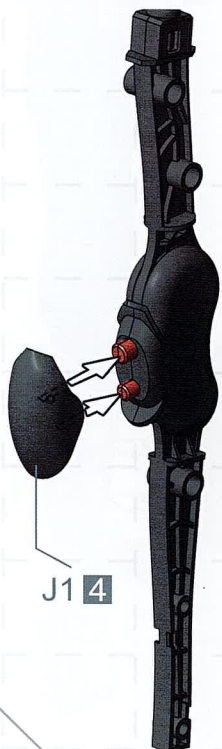
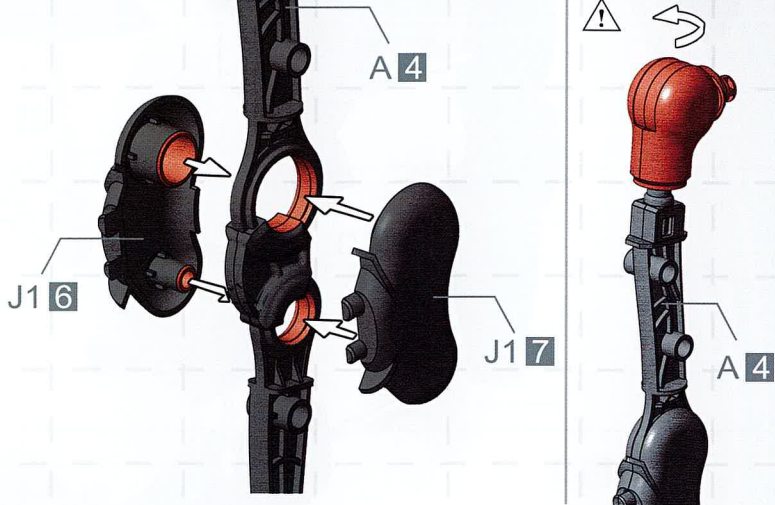
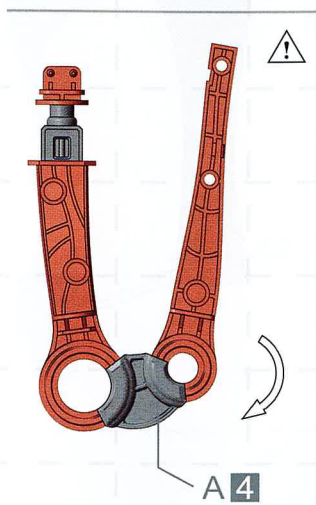
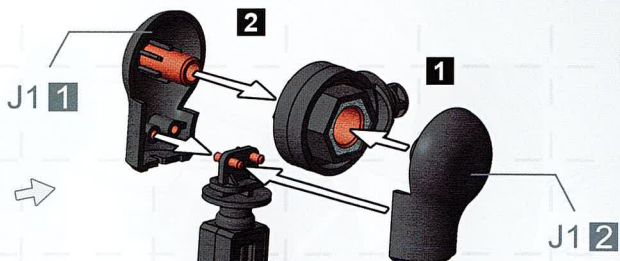
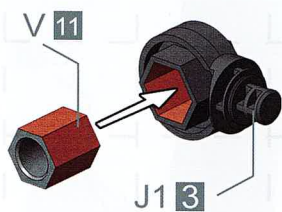

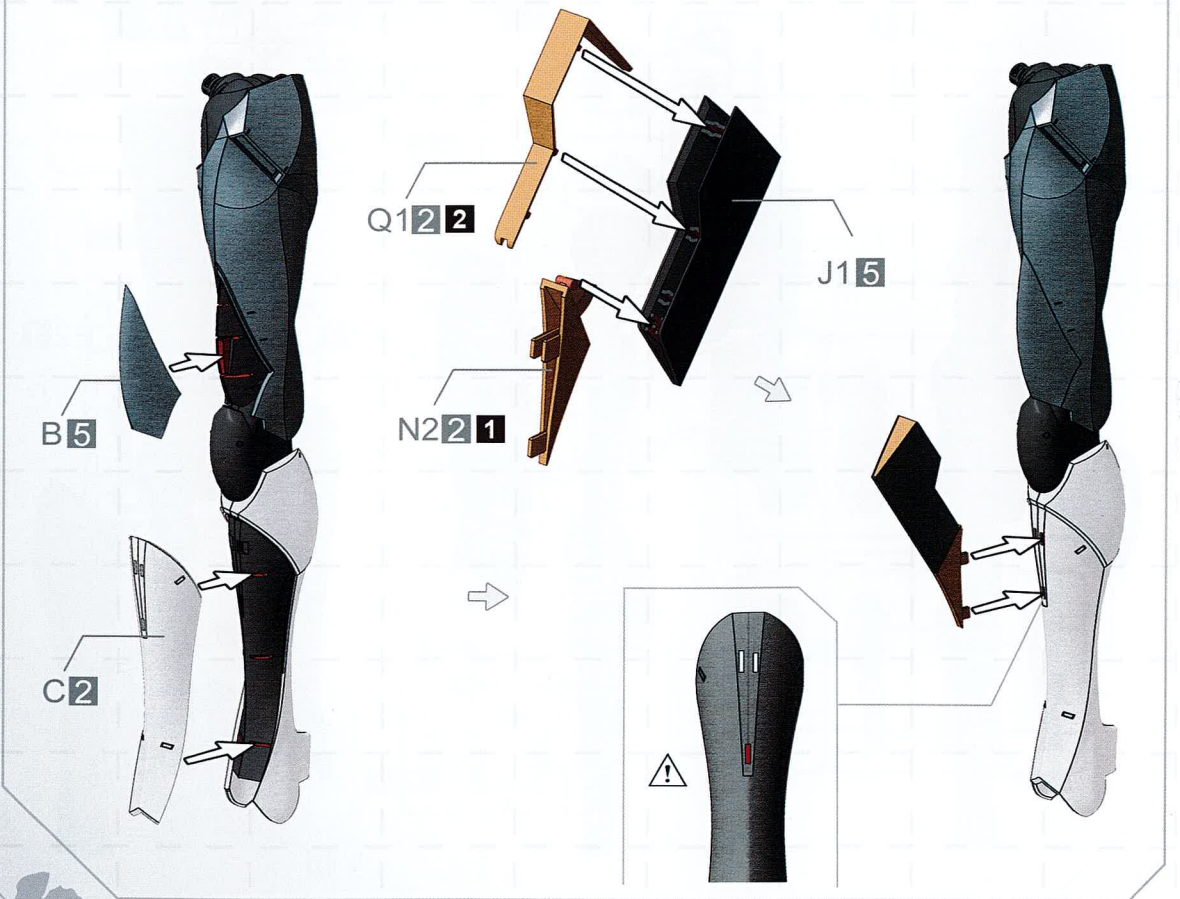
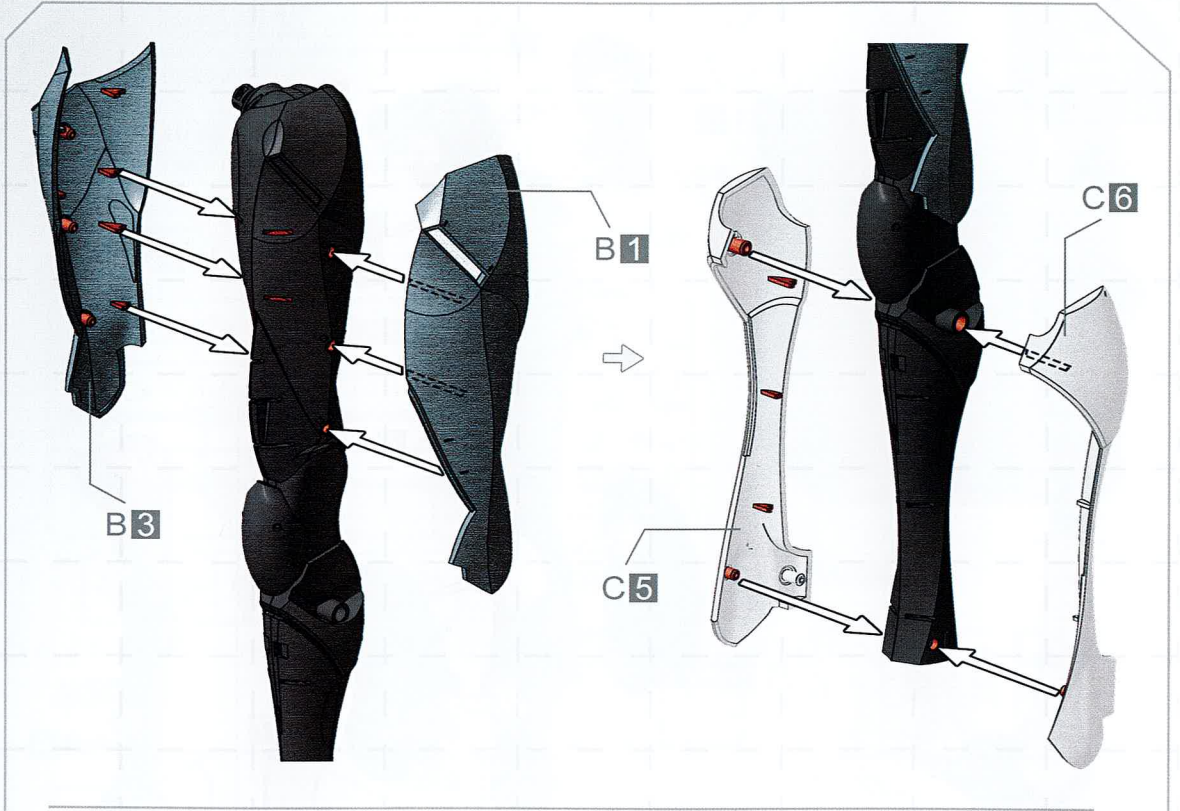

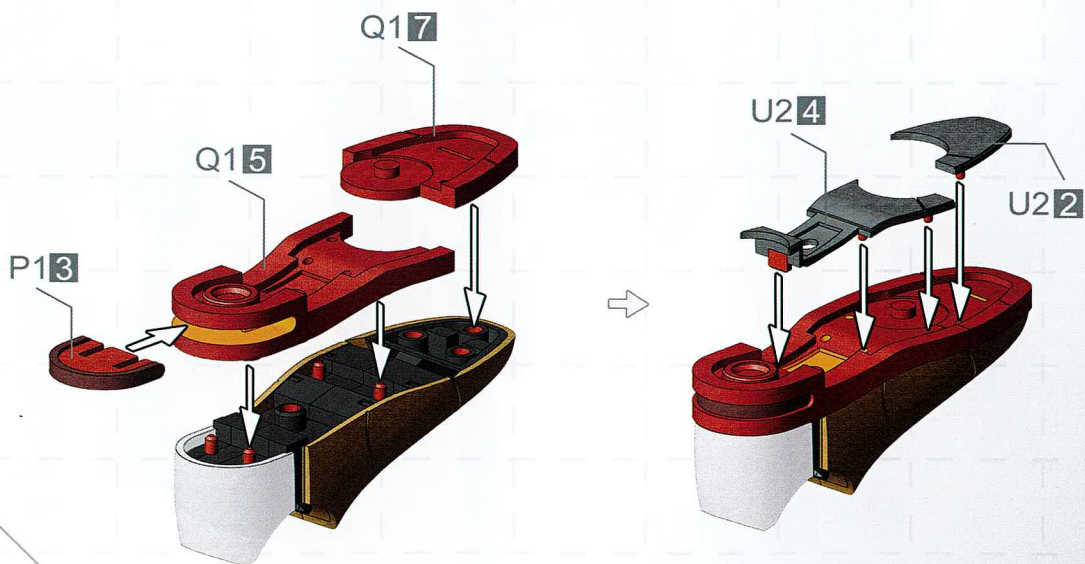
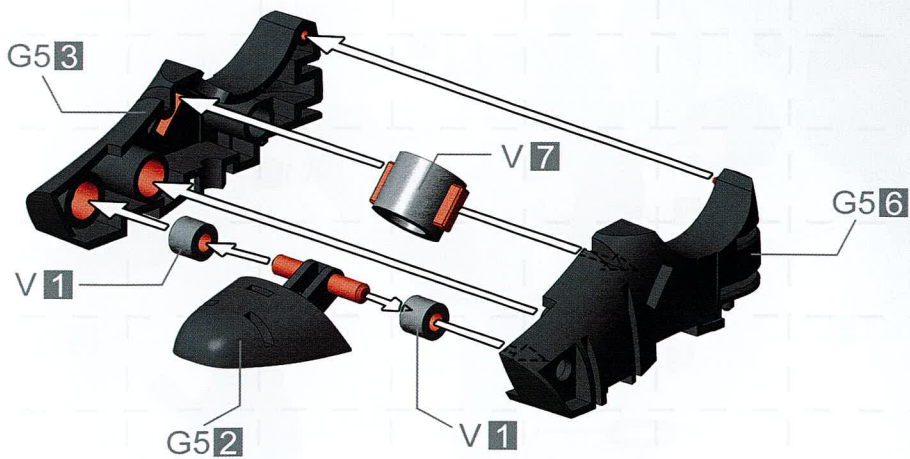



右腿
Right leg
右足

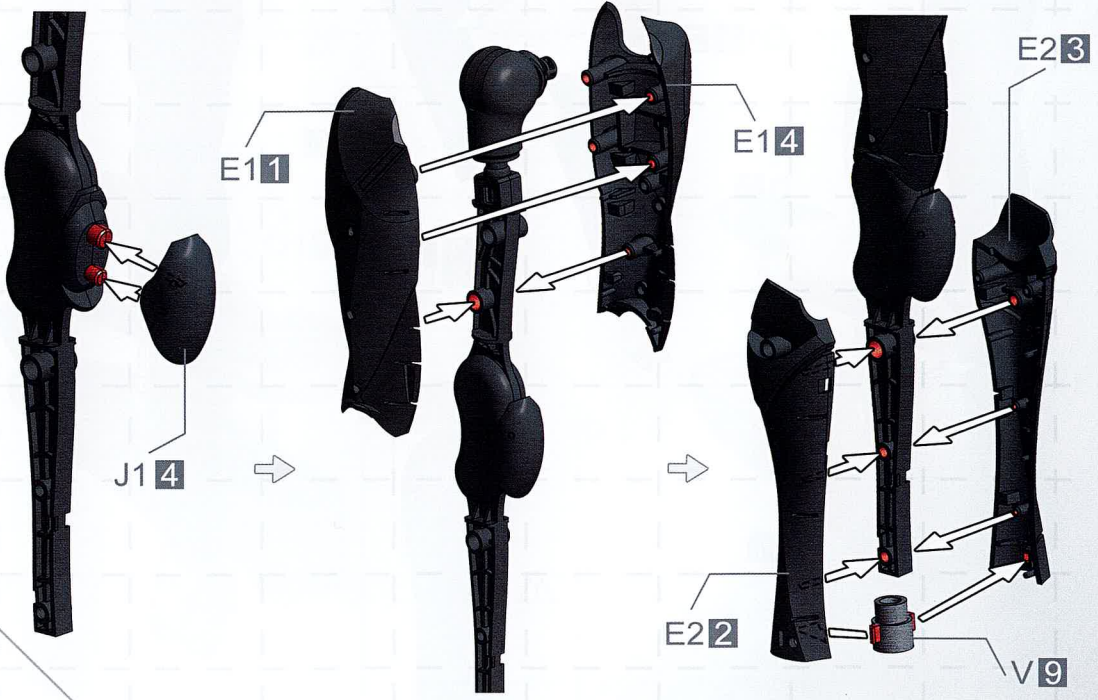
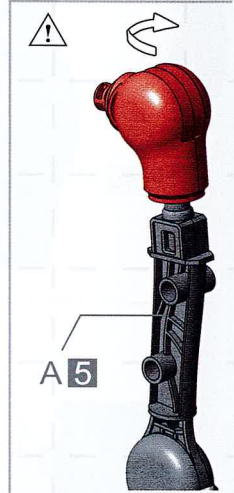
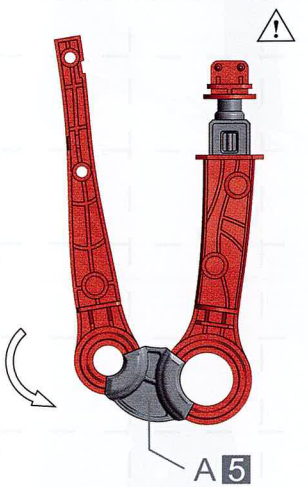
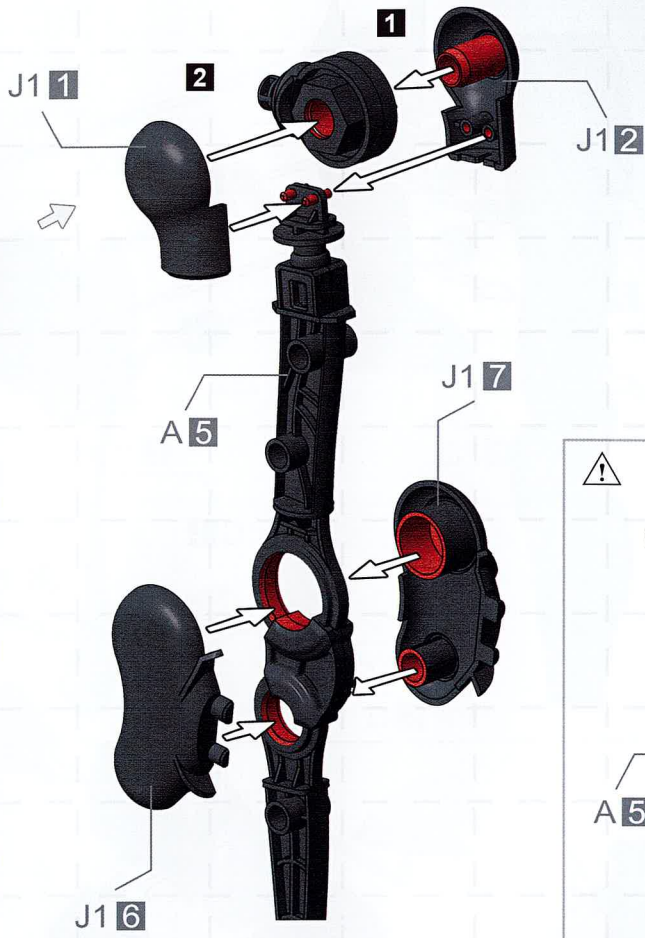
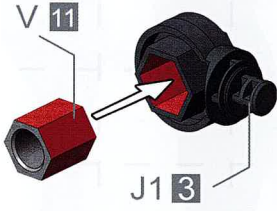

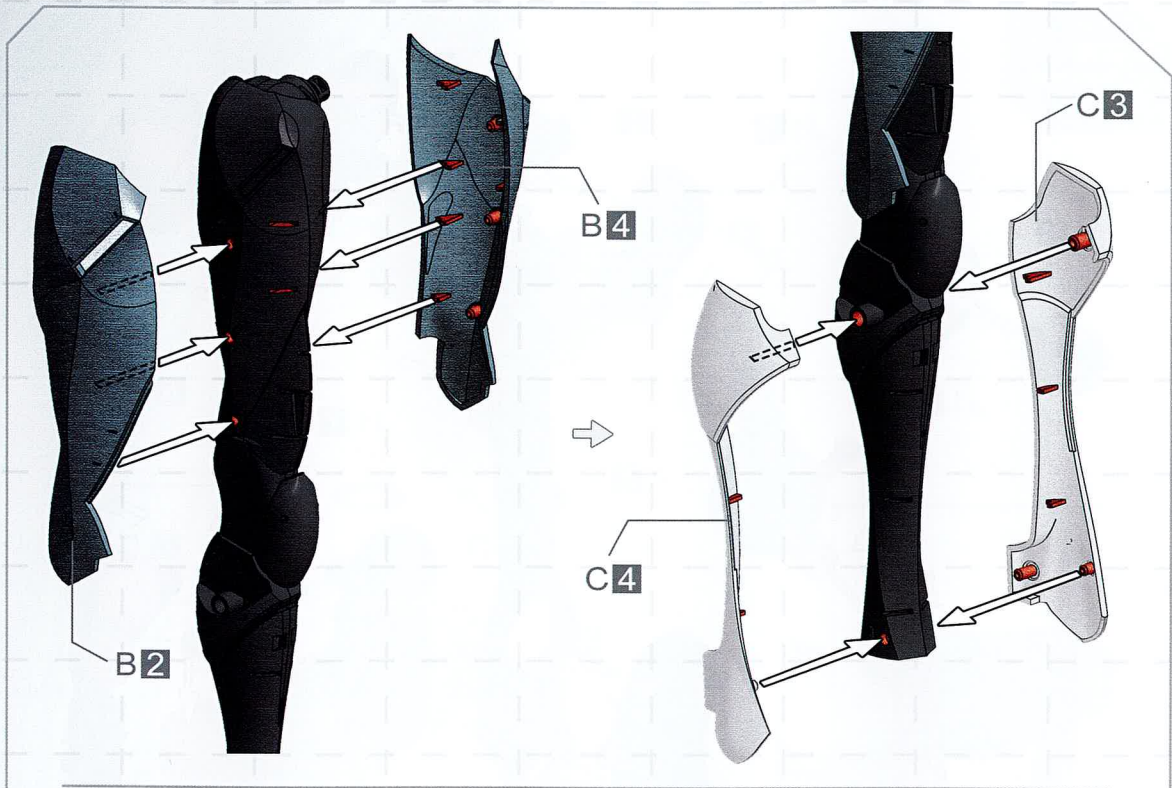

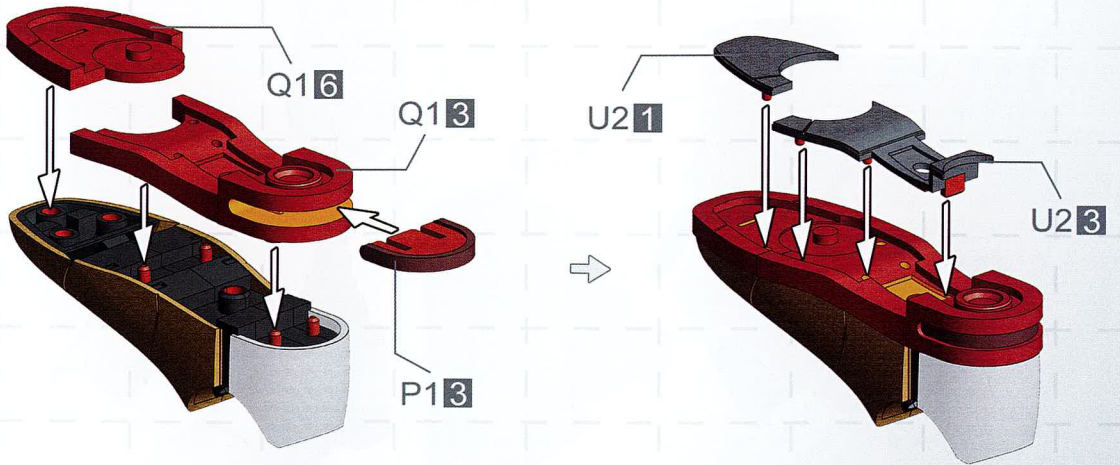
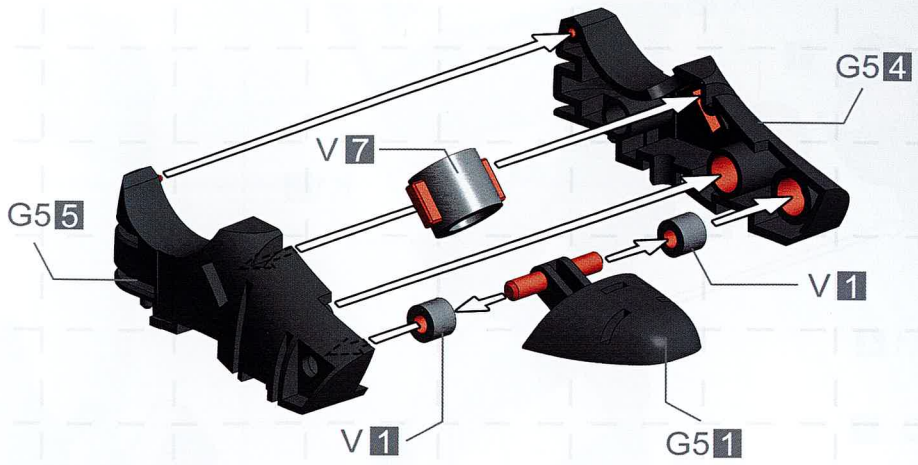

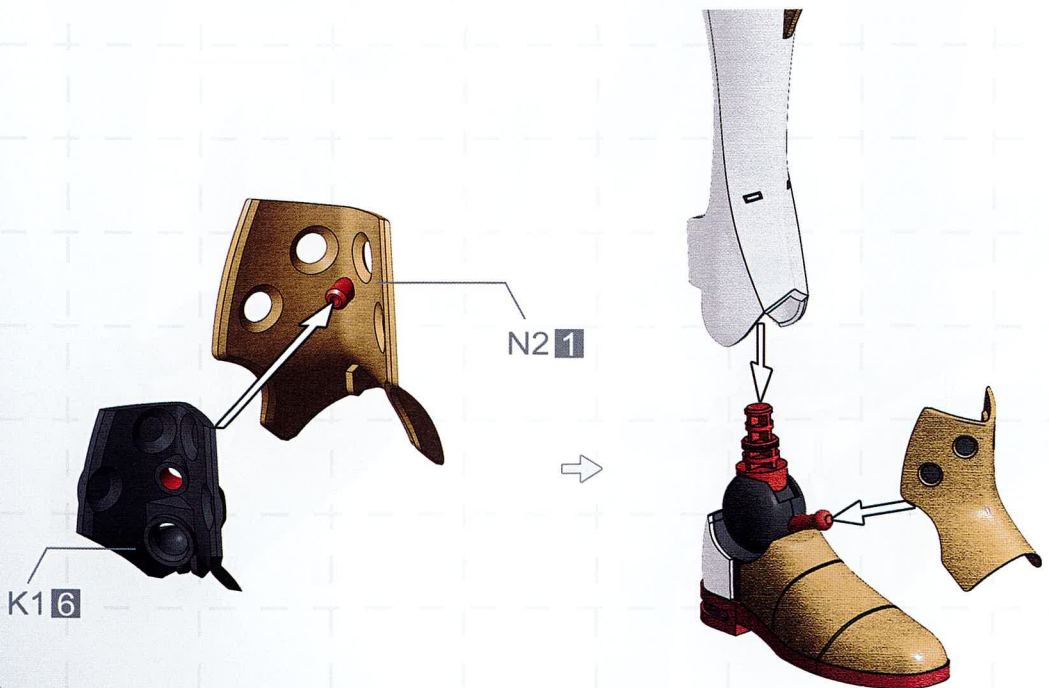

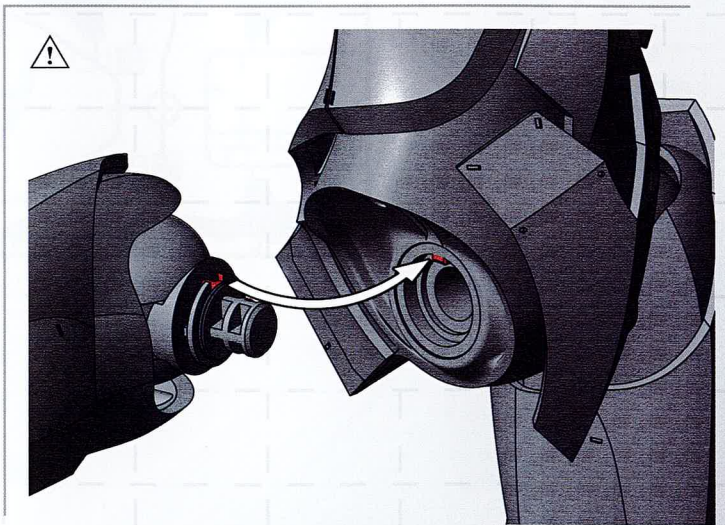
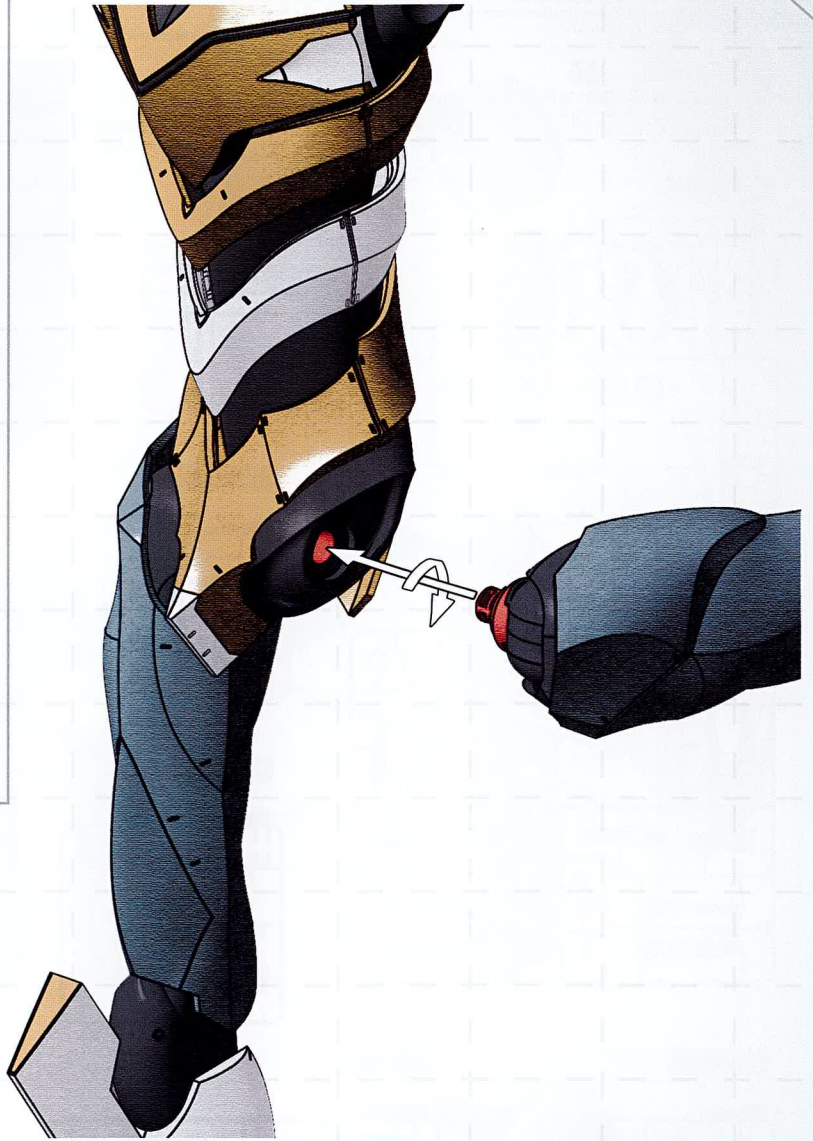
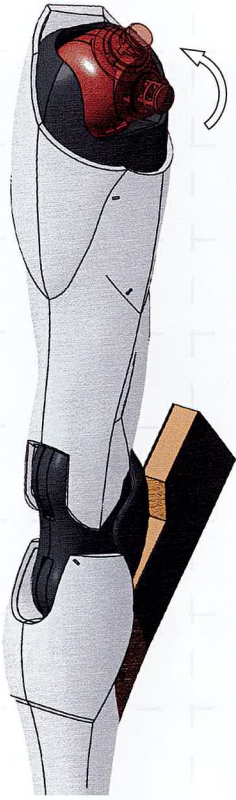

手臂组装

腕の組み立て

本步骤需要以下板件/零件。
For this step, please use the following sprues/parts.
このステップでは、以下のランナー/パーツを使用します。

⚠️ □ 不使用零件
Parts not needed
使用しないパーツ

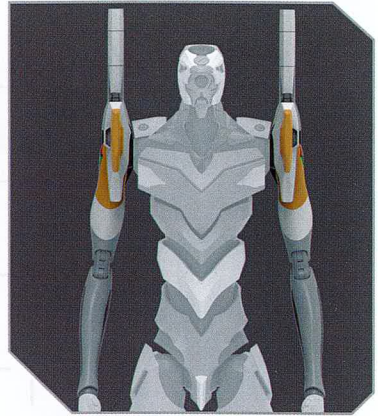

H3 Parts

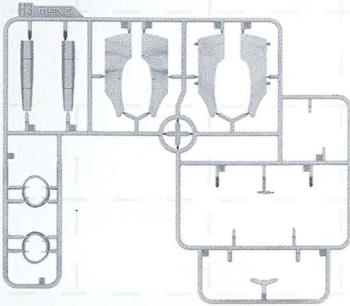

H9 Parts

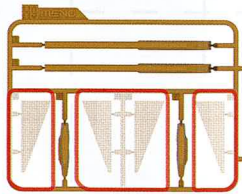

N3 Parts

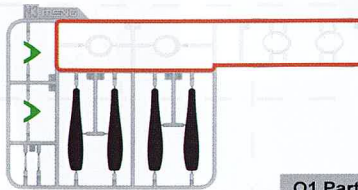

H6 Parts

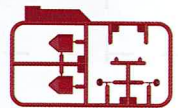

G4 Parts

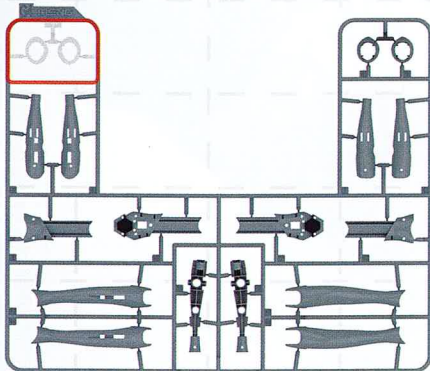

Q1 Parts

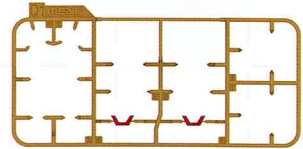

V Parts

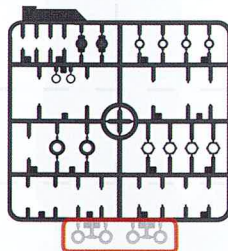

J2 PartsX2

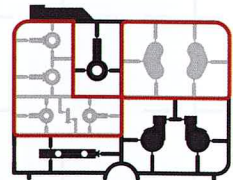

M1 Parts

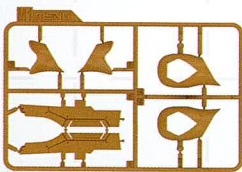

H2 Parts

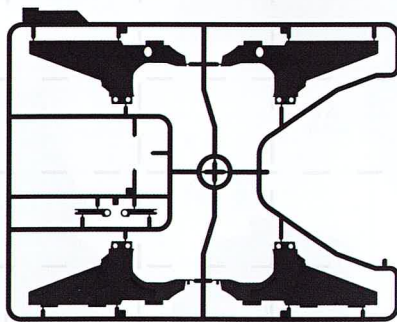

X1 Parts

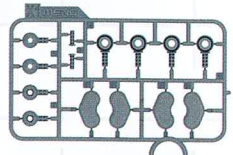

×2

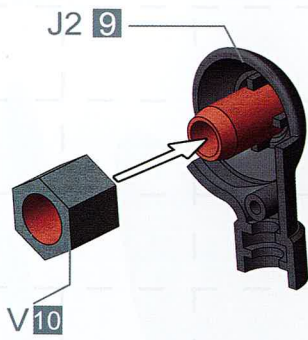

×2

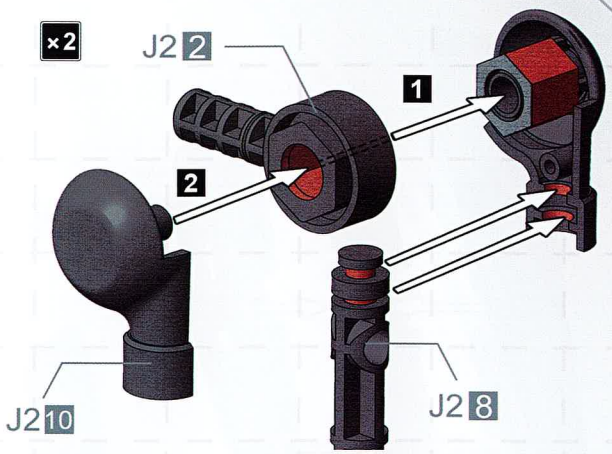

左臂
Left arm
左腕

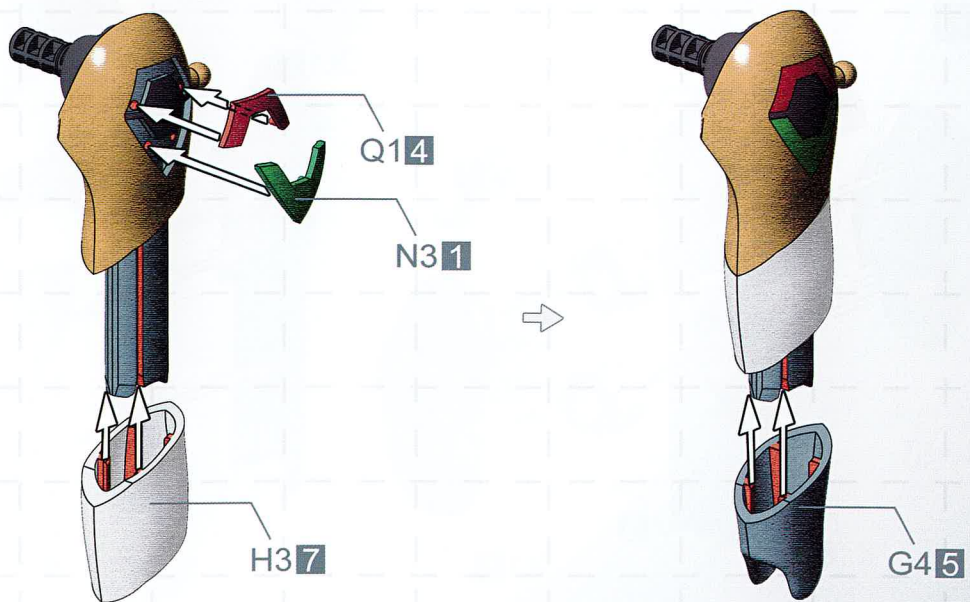
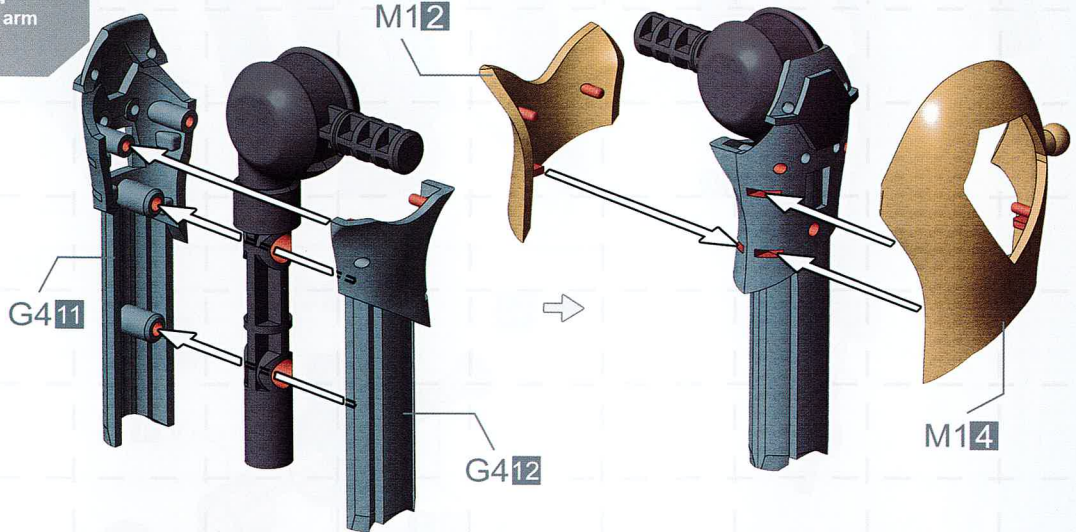

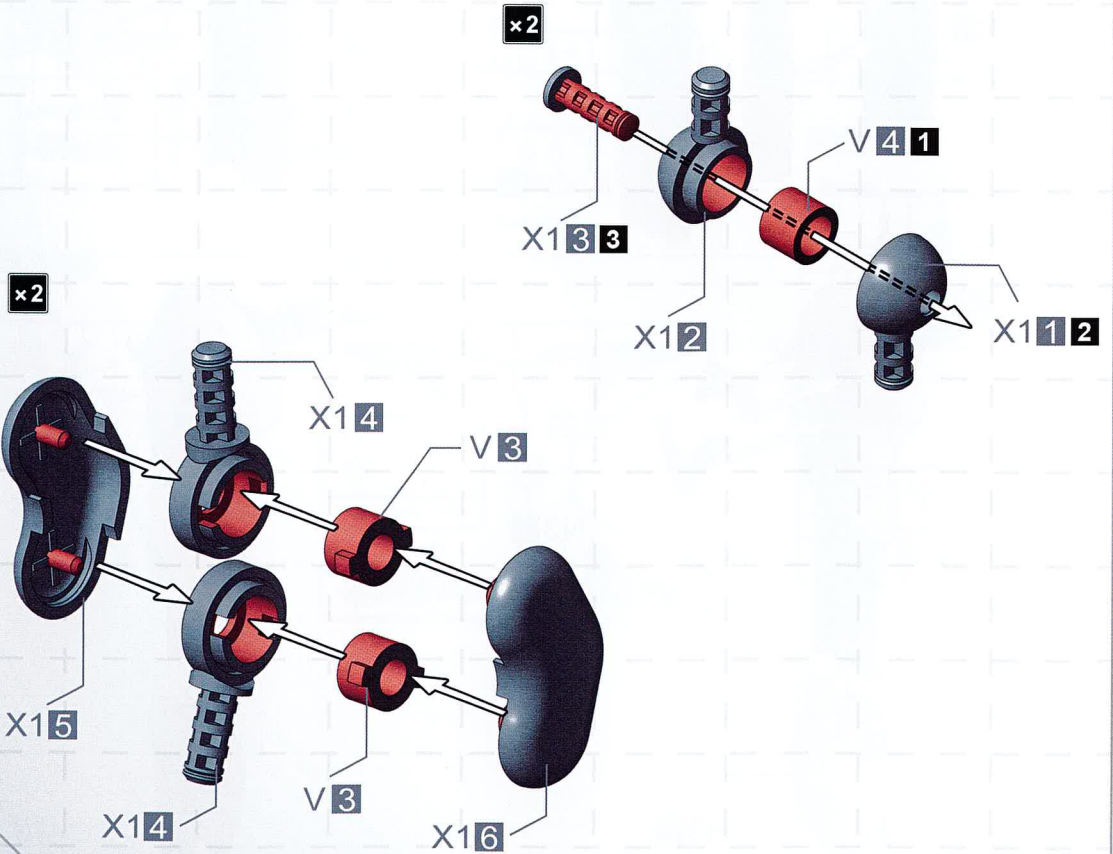
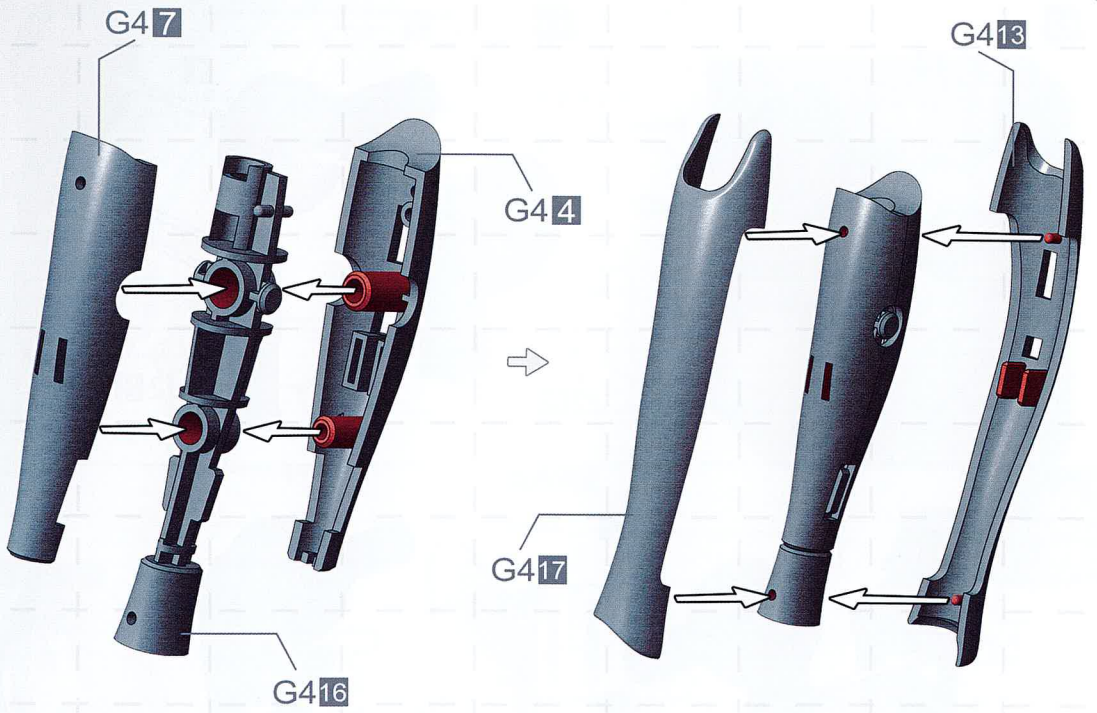

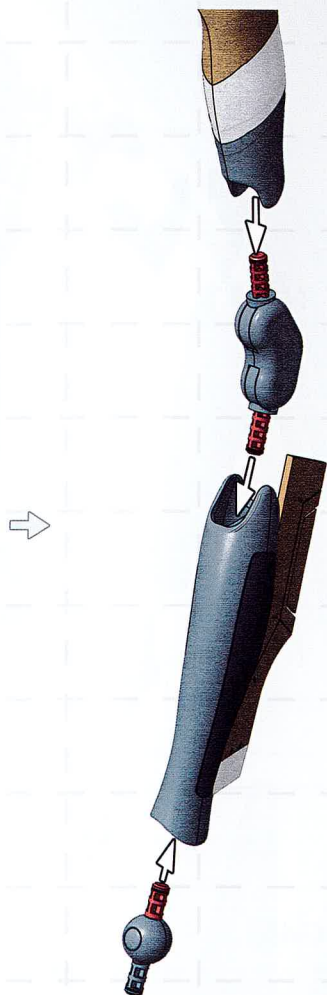
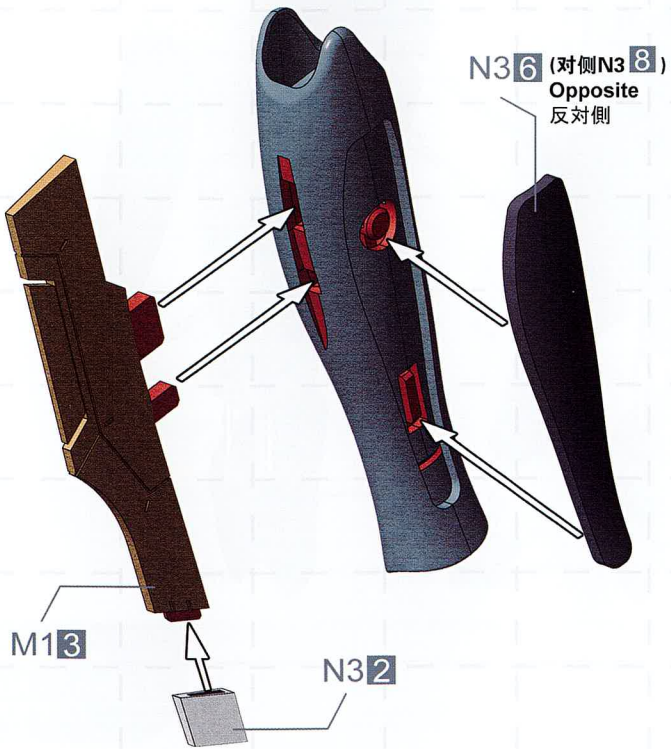

右臂
Right arm
右腕

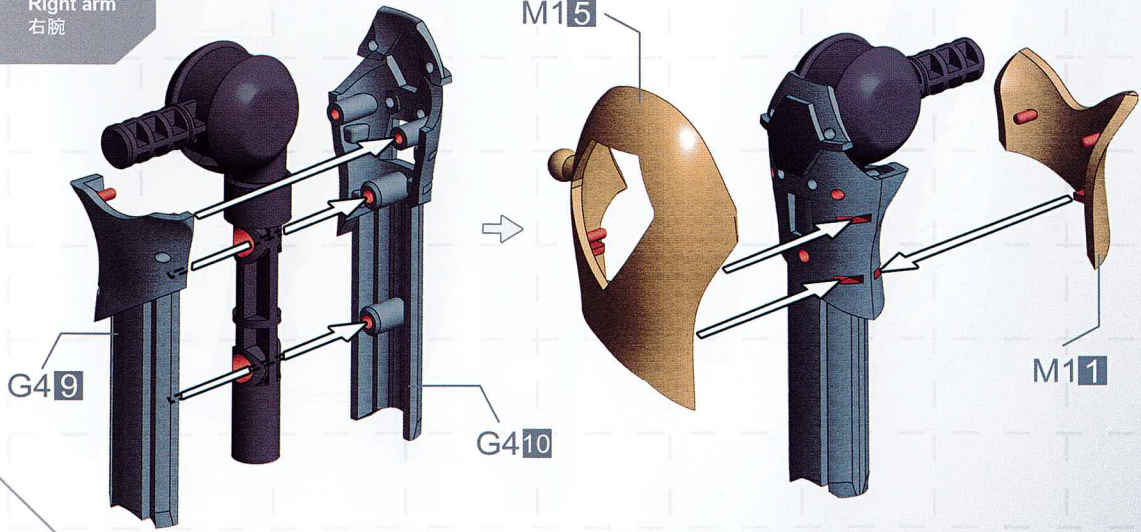

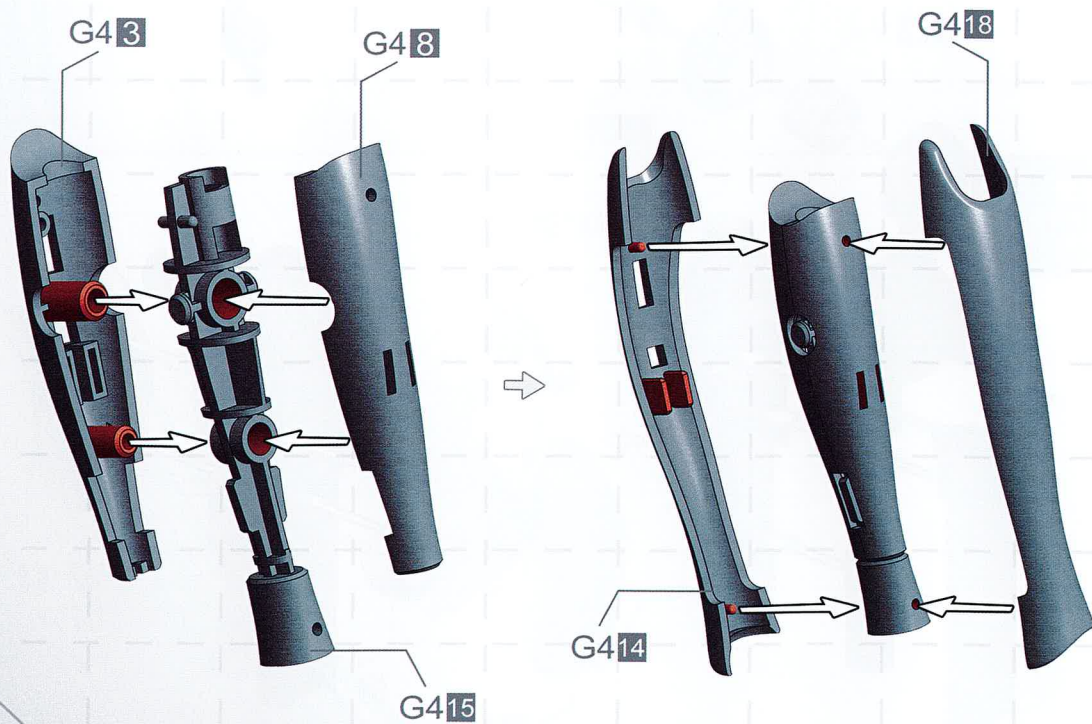
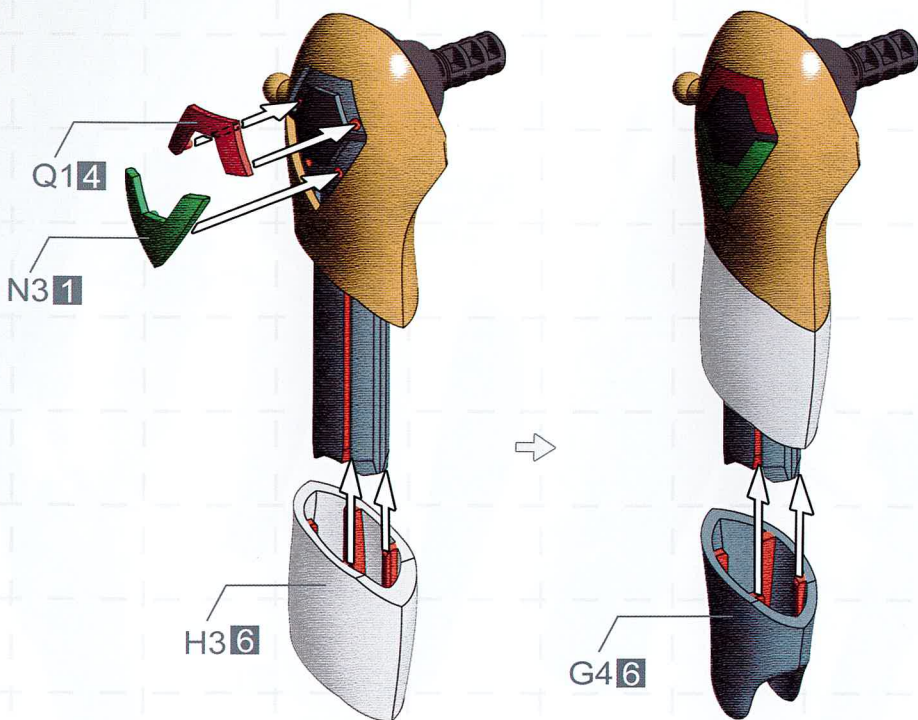

N3 5 (对侧 N3 7)
Opposite
反对侧

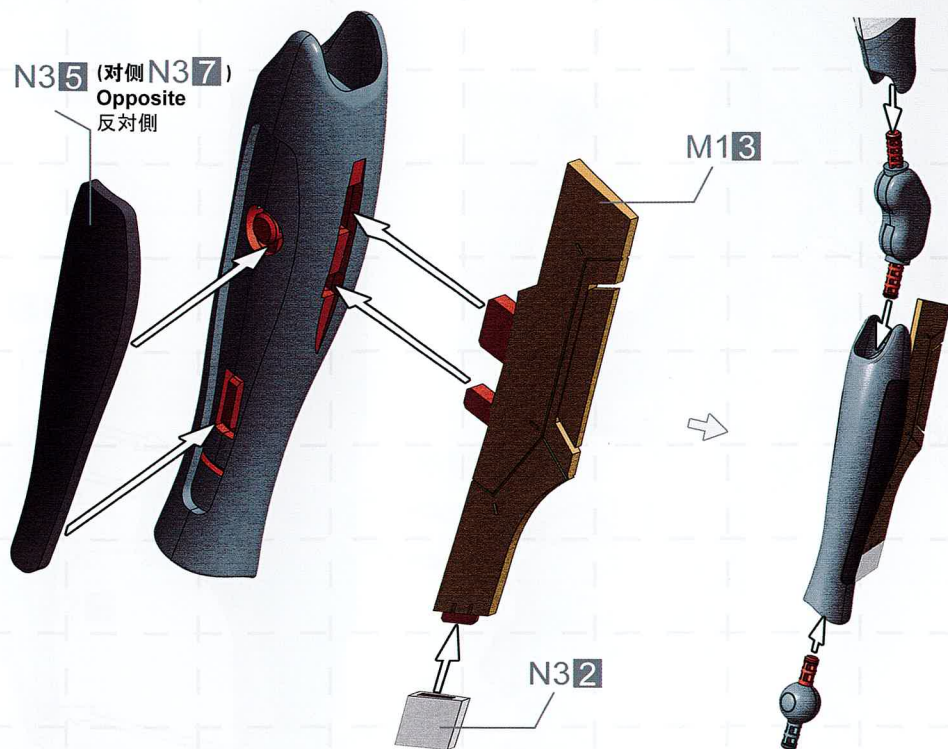

左臂拘束器
Left arm restraint
左腕拘束具

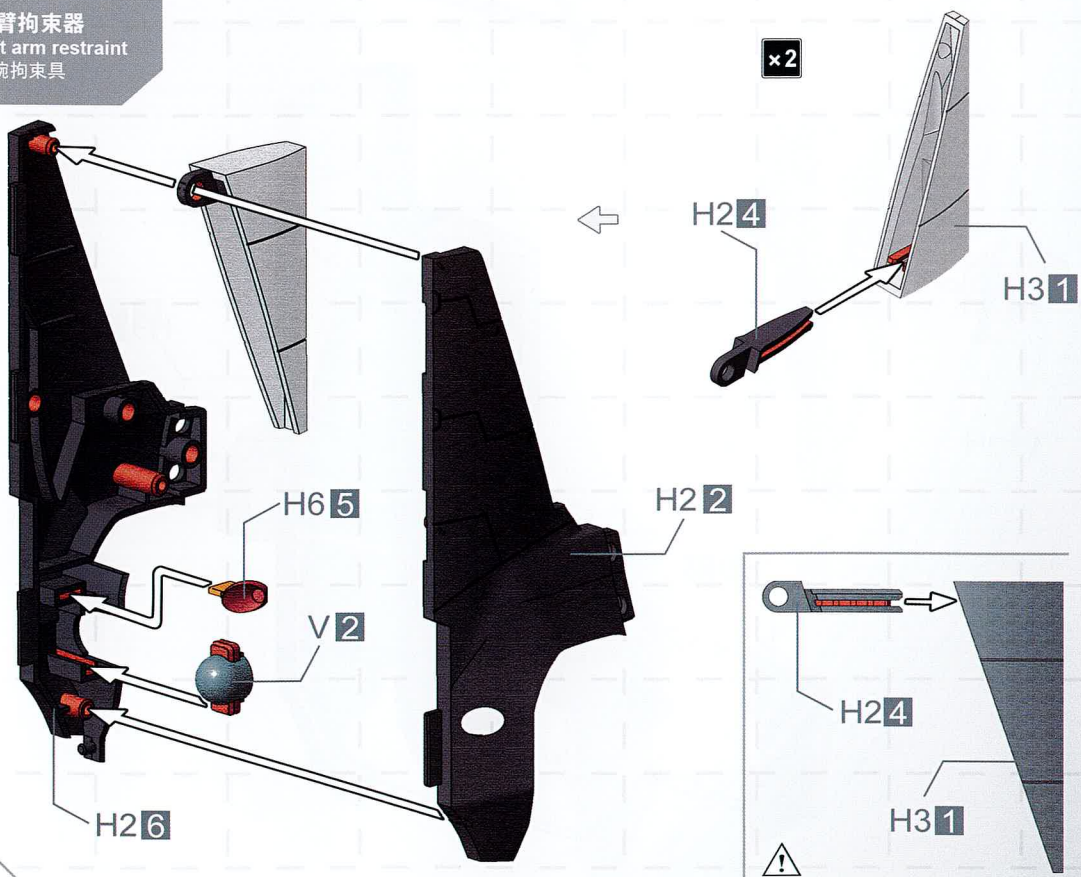

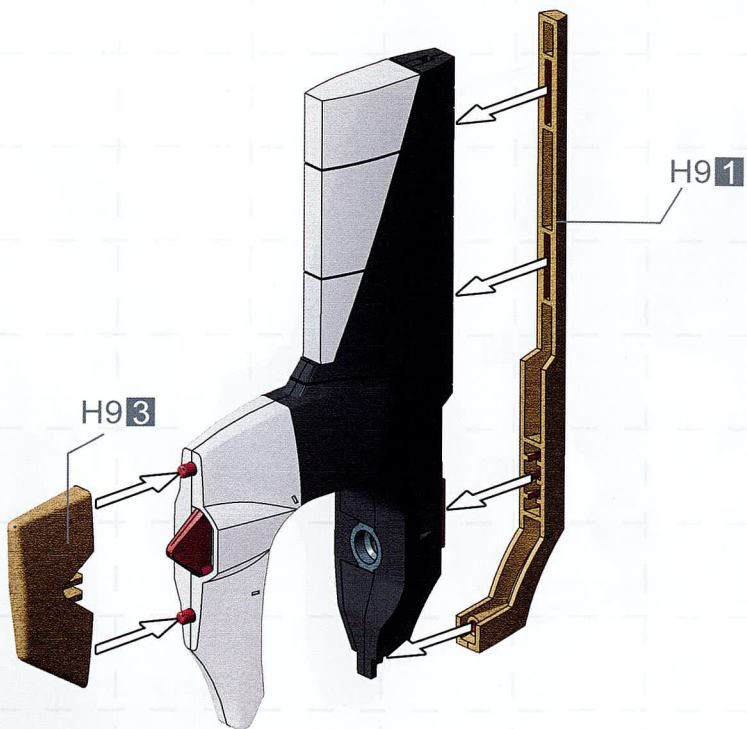
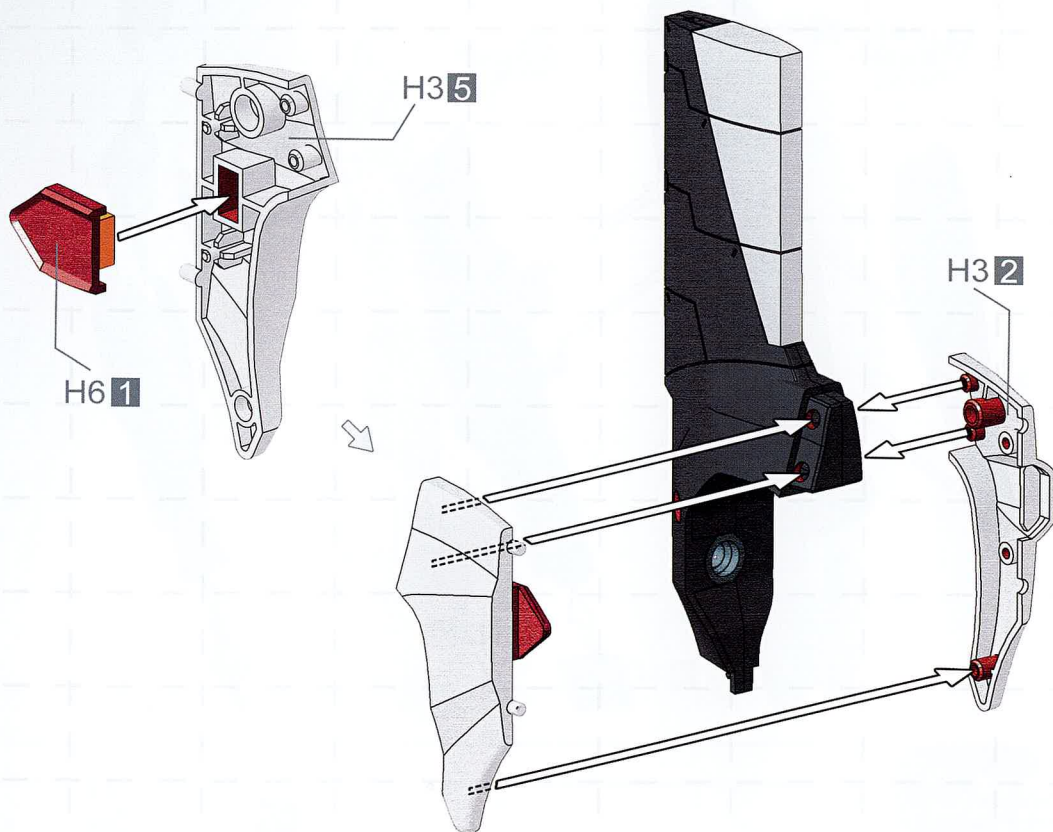

右臂拘束器
Right arm restraint
右腕拘束具

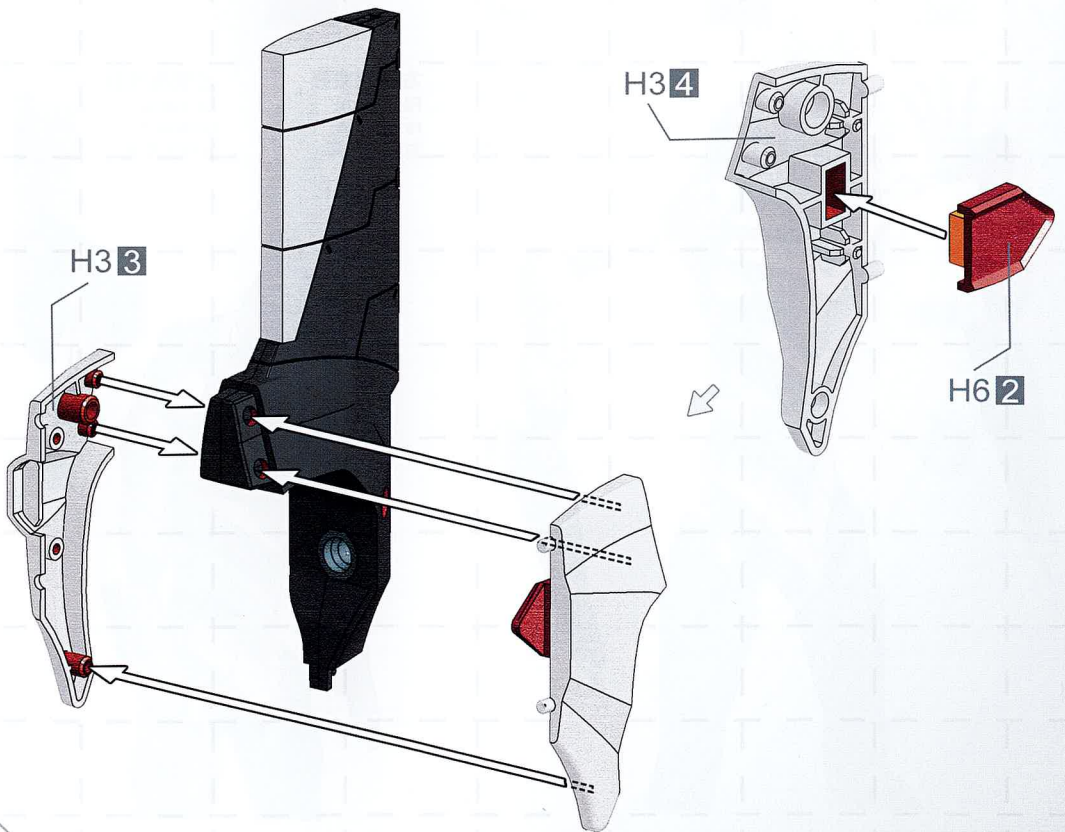
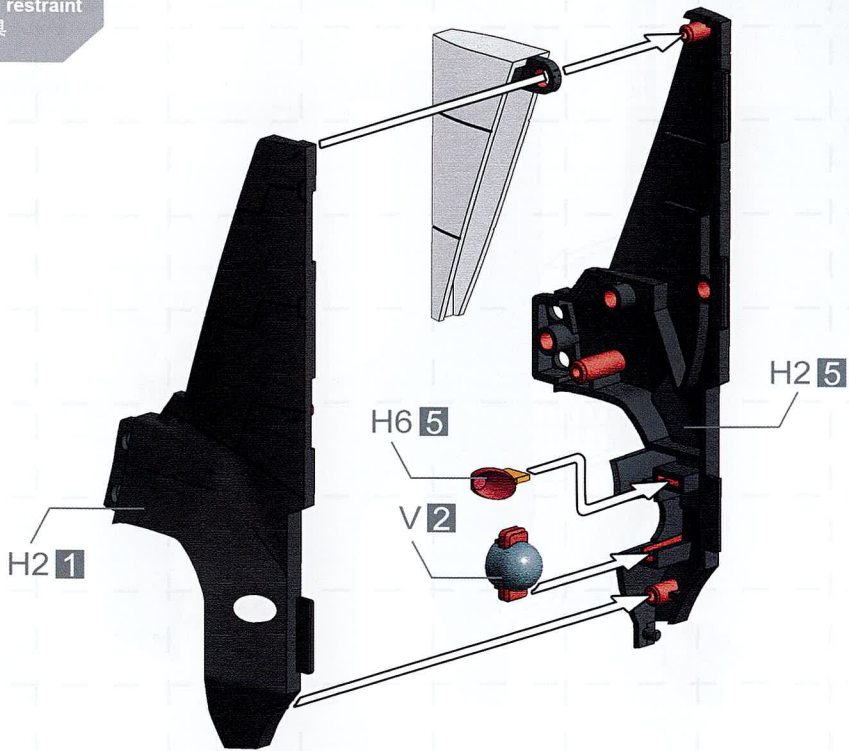

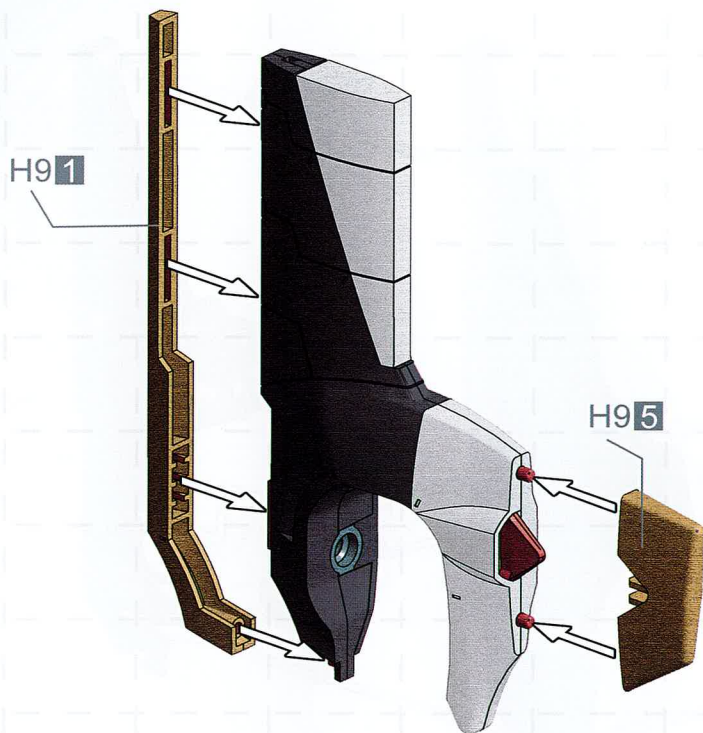

右臂拘束器
Right arm
restraint
右腕拘束具

左臂拘束器
Left arm
restraint
左腕拘束具

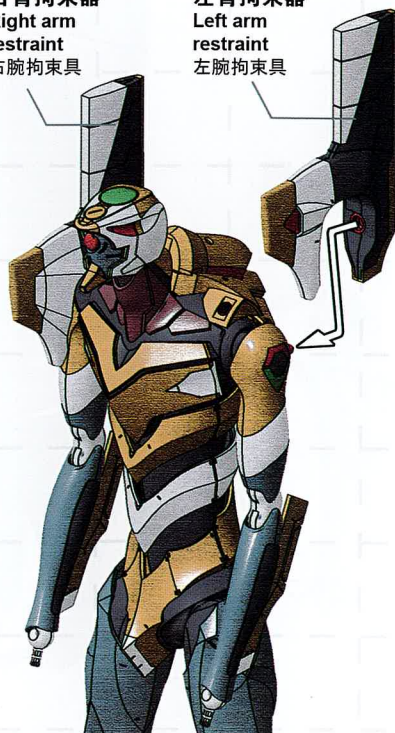

5

HAND ASSEMBLY

手型組装

手首の組み立て

本手順需要以下板件/零件。
For this step, please use the following sprues/parts.
このステップでは、以下のランナー/パーツを使用します。

⚠ 不使用零件
Parts not needed
使用しないパーツ

W Parts

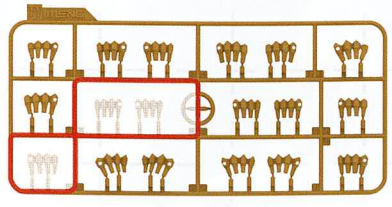

R2 Parts

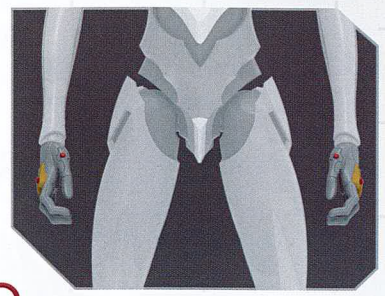
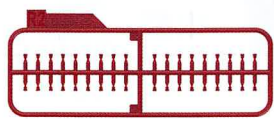

A-R



C-R



E-R



F-R



G-R



A-L



C-L



E-L



F-L



G-L



H-R



H-L



J-R



J-L



B-R



左手A
Left hand A
左手A

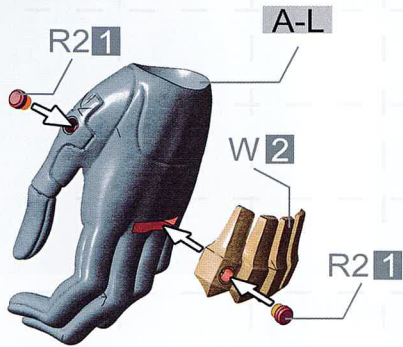

右手A
Right hand A
右手A

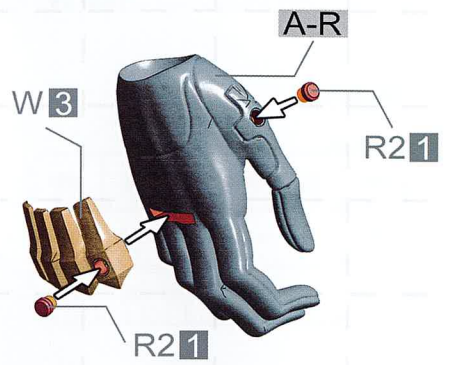

左手C
Left hand C
左手C

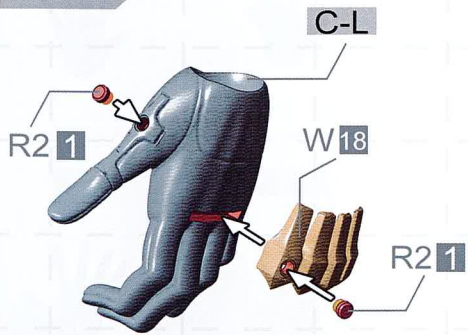

右手C
Right hand C
右手C

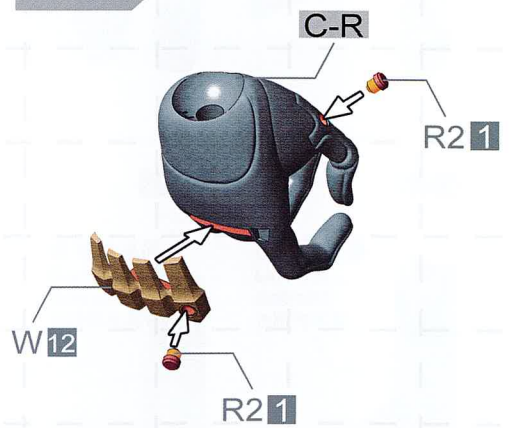

左手E
Left hand E
左手E

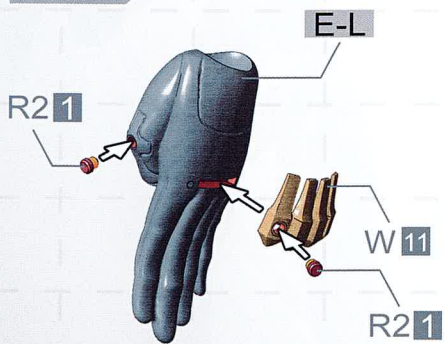

右手E
Right hand E
右手E

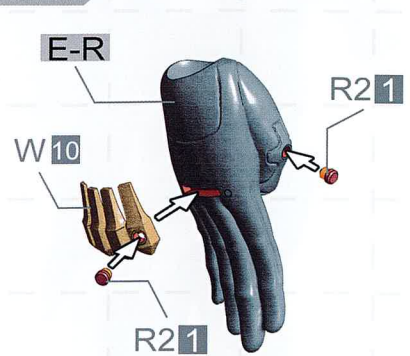

左手F
Left hand F
左手F

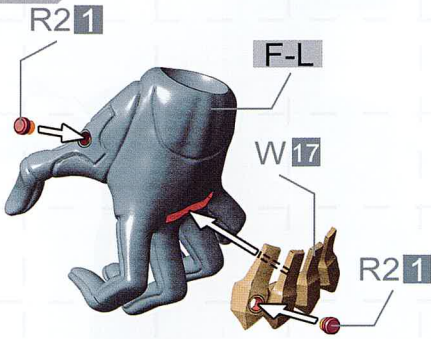

右手F
Right hand F
右手F

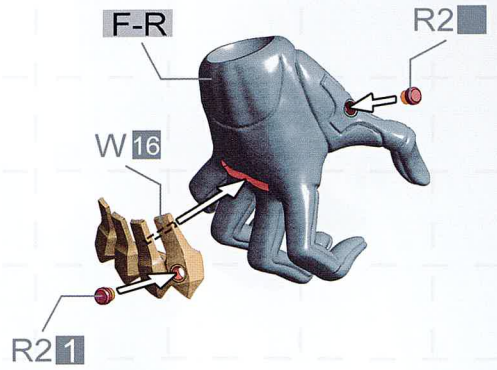

左手G
Left hand G
左手G

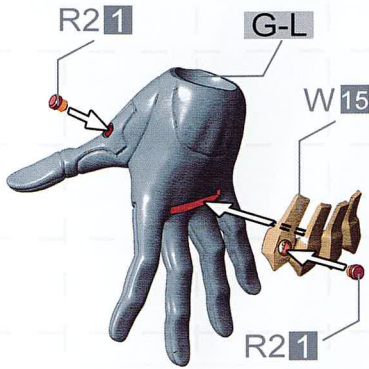

右手G
Right hand G
右手G

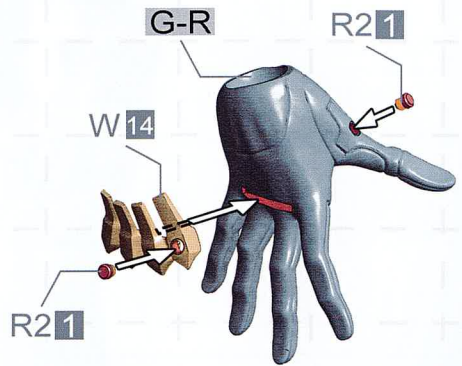

左手J
Left hand J
左手J

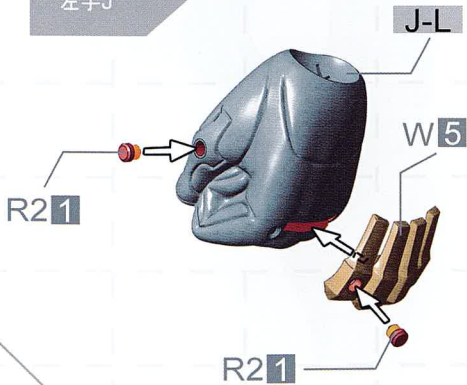

右手J
Right hand J
右手J

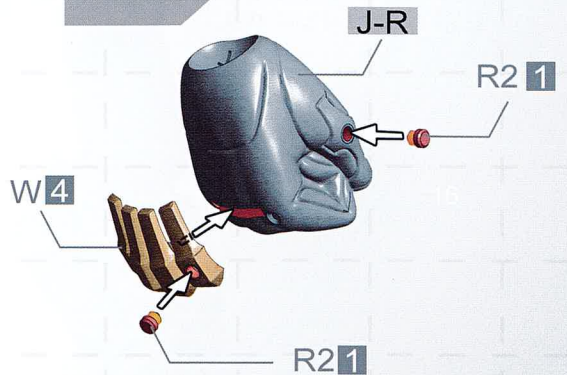

左手H
Left hand H
左手H

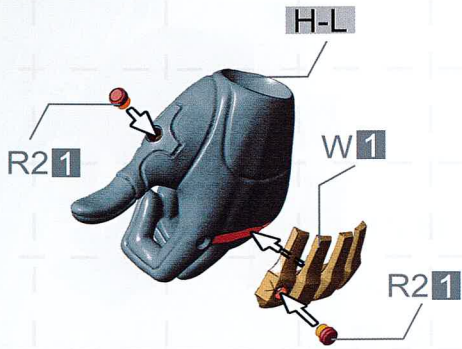

右手H
Right hand H
右手H

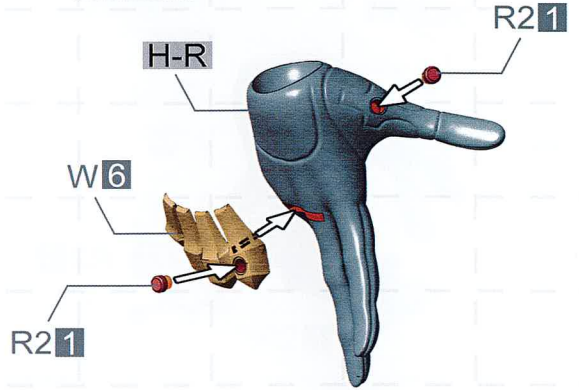

右手B
Right hand B
右手B

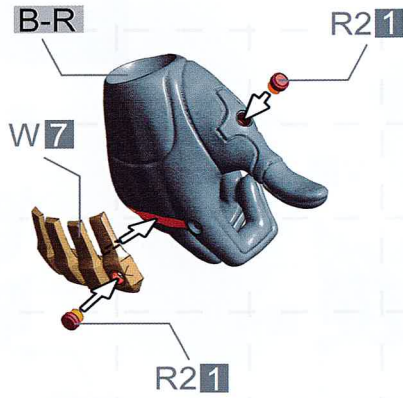

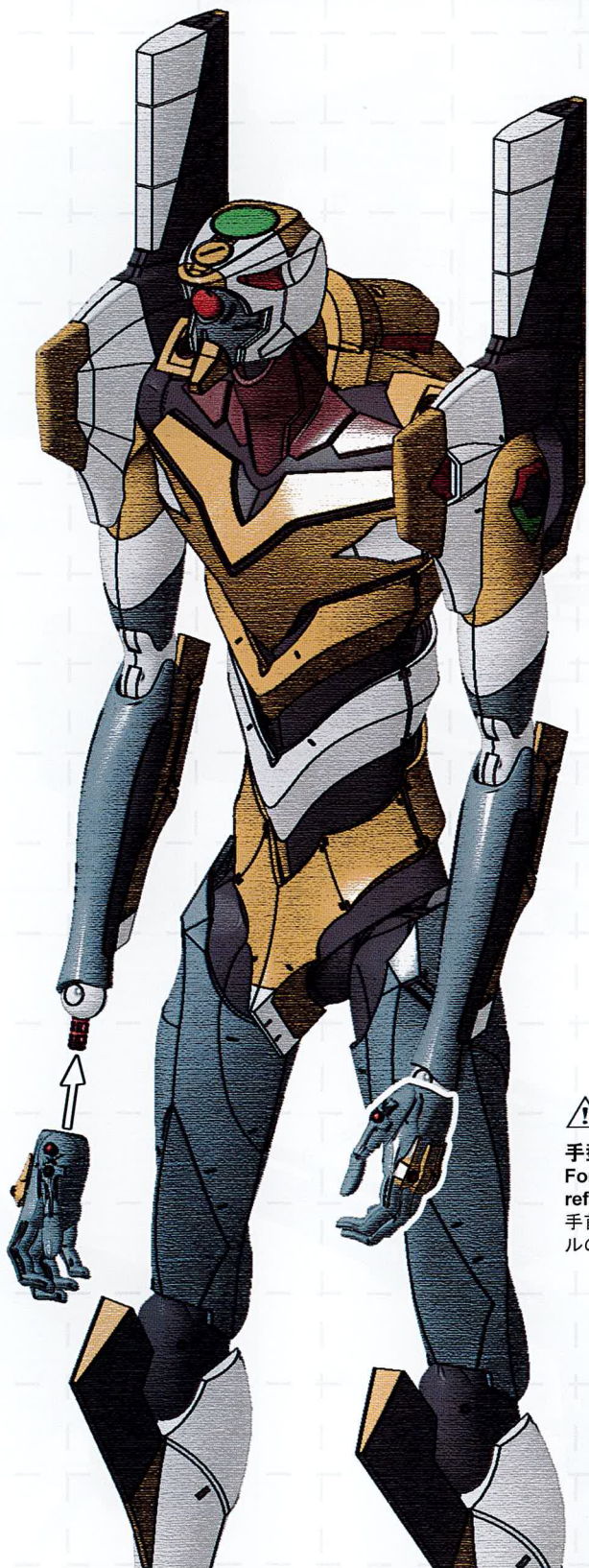

手型使用请参看53、54页。
For the hand options, please
refer to page 53 and 54.

手首の使用については、マニュアル
のP53とP54を参照してください。

电磁来福枪组装

パレットライフルの組み立て

本步骤需要以下板件/零件。
For this step, please use the following sprues/parts.
このステップでは、以下のランナー/パーツを使用します。

Z1 Parts

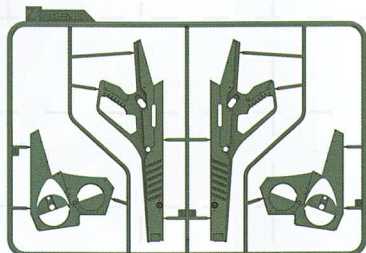

Z2 Parts

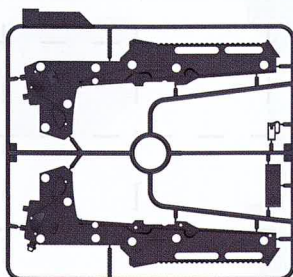

Z3 Parts



Z4 Parts



Z5 Parts



弹簧
Spring
スプリング



Z2 2

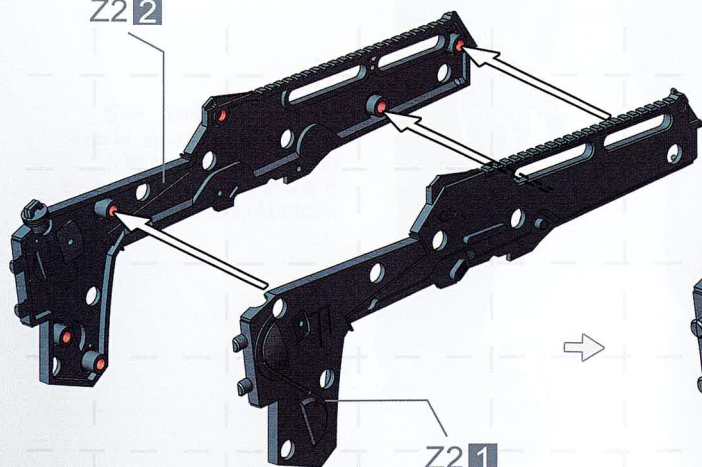

Z2 1

Z3 1 (对侧 Z3 2)
Opposite
反対側

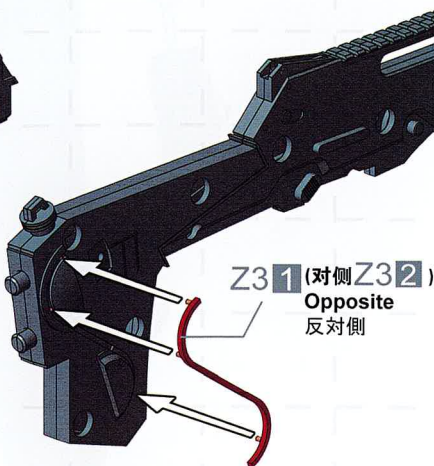

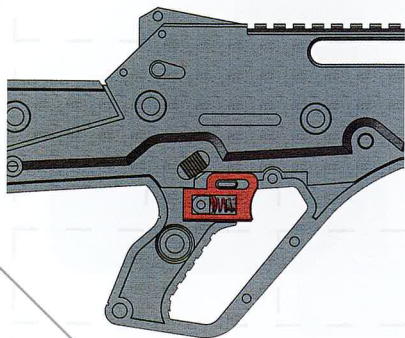
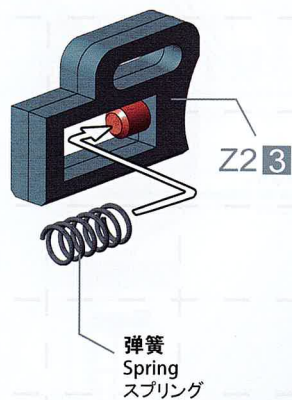
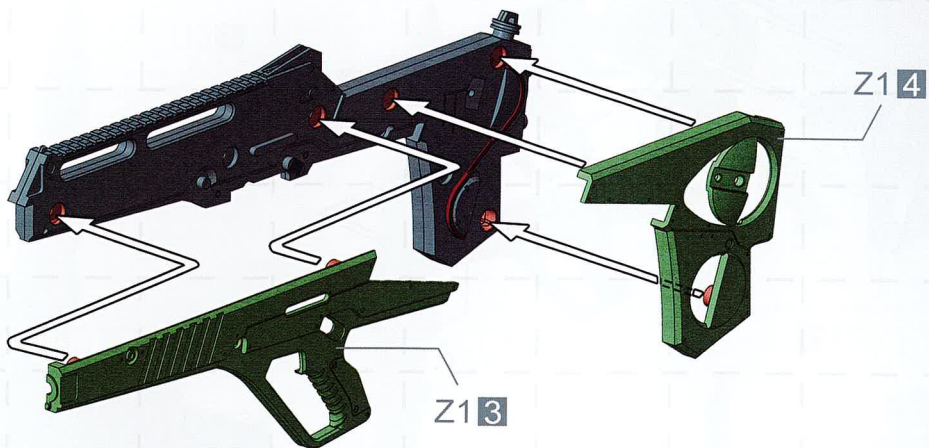

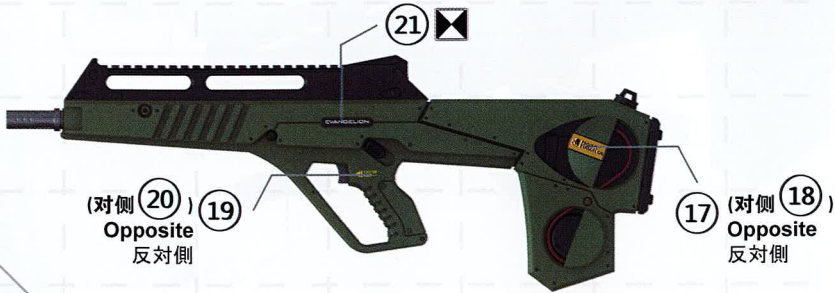
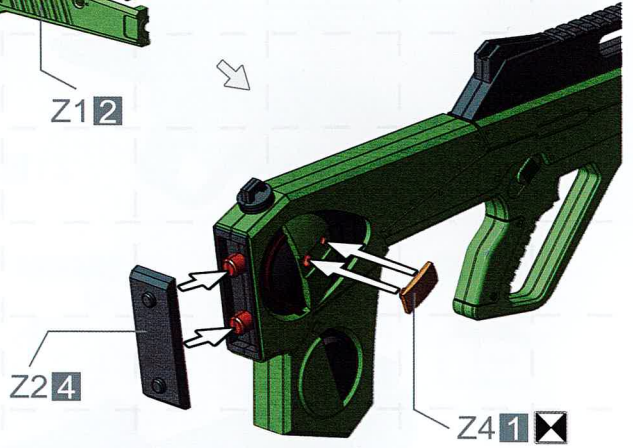
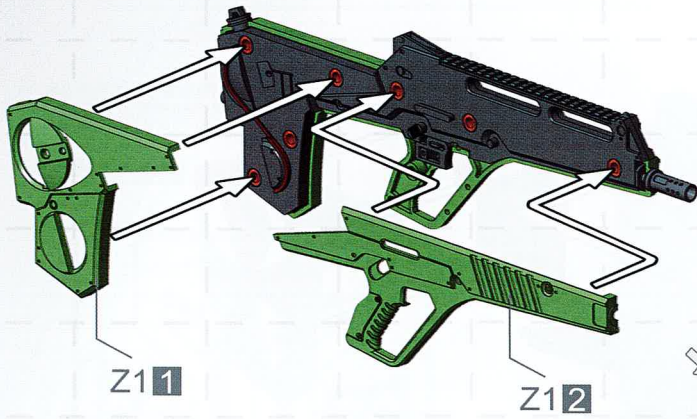

7

PROGRESSIVE KNIFE ASSEMBLY

高振动粒子刀组装

プログレッシブナイフの組み立て

本步骤需要以下板件/零件。
For this step, please use the following sprues/parts.
このステップでは、以下のランナー/パーツを使用します。

U3 Parts

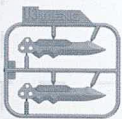

K3 Parts X2



N7 Parts

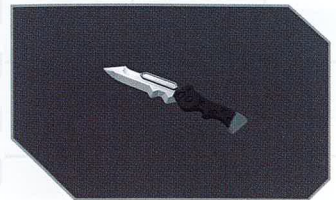

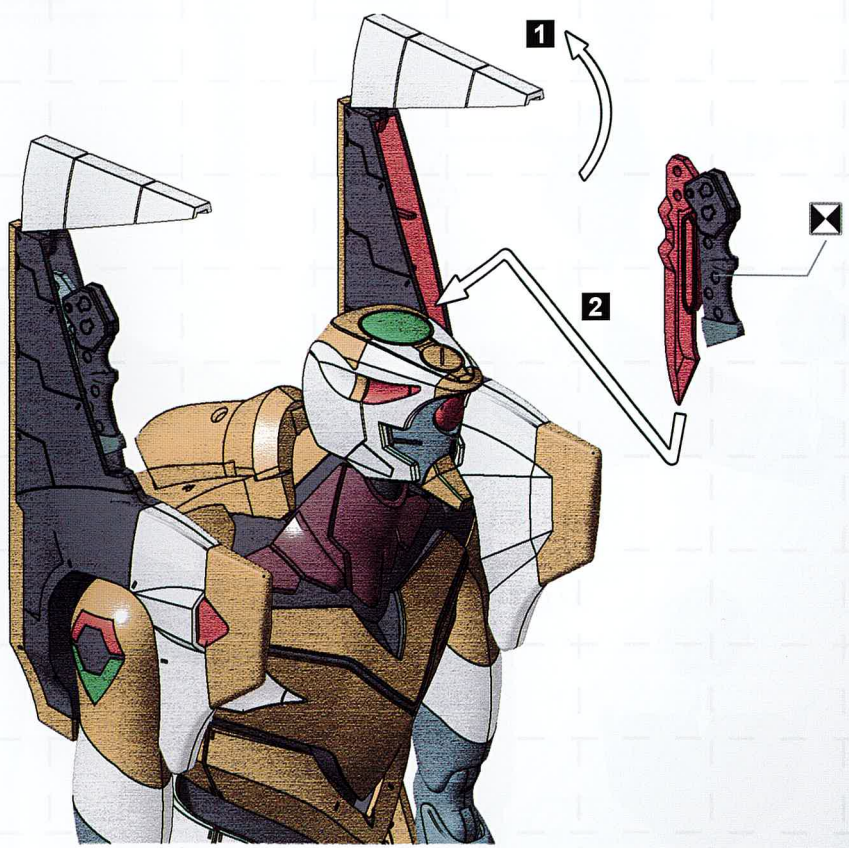
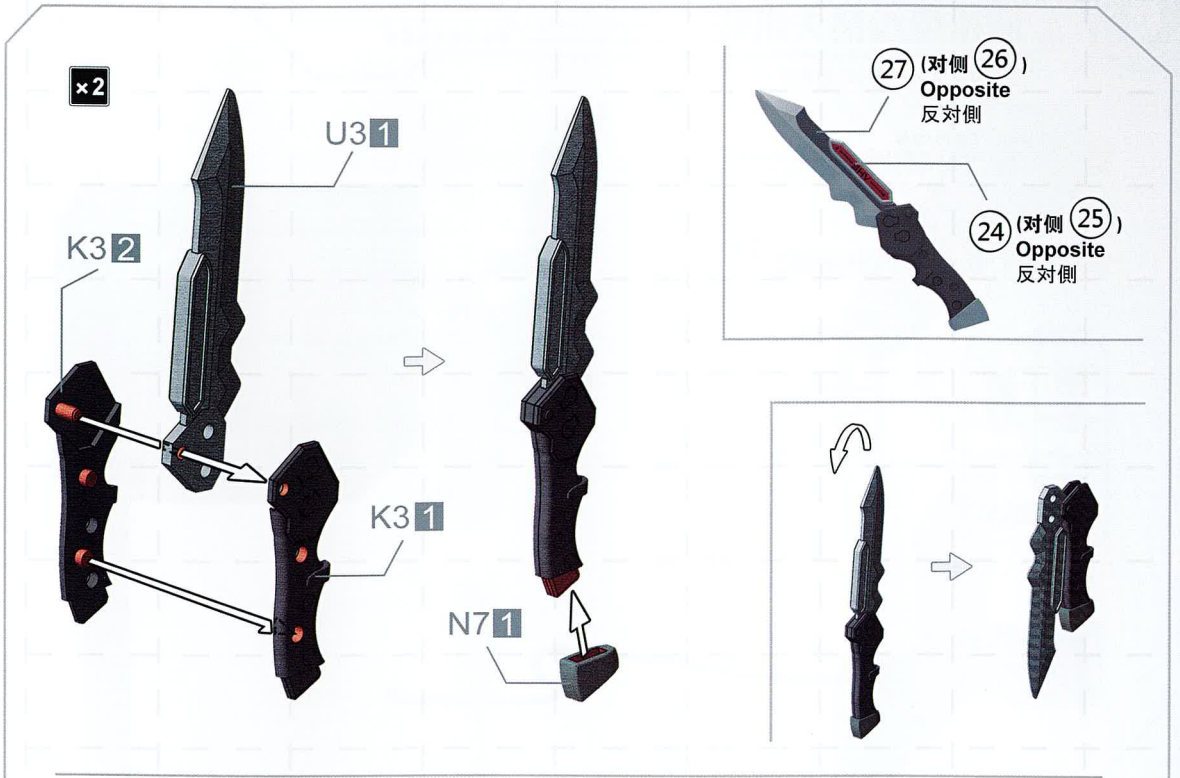

脐带缆线插头组装

アンビリカルケーブルの組み立て

本步骤需要以下板件/零件。
For this step, please use the following sprues/parts.
このステップでは、以下のランナー/パーツを使用します。

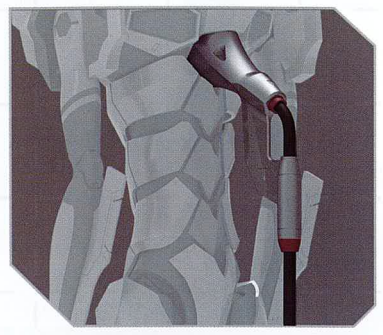
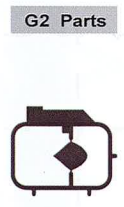
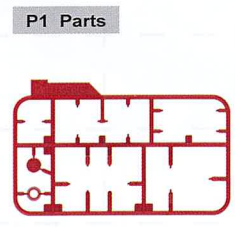

软胶管
Vinyl pipe
ビニールパイプ

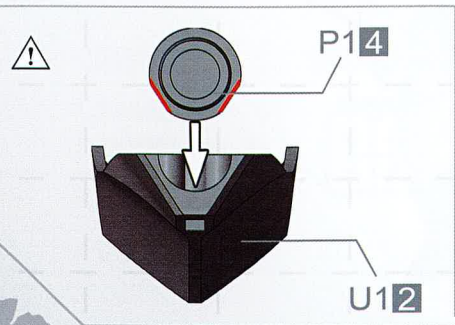
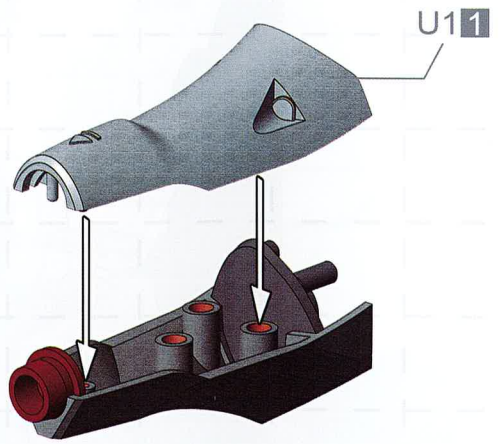
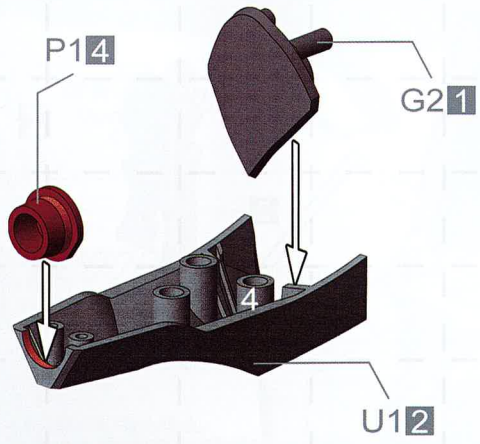

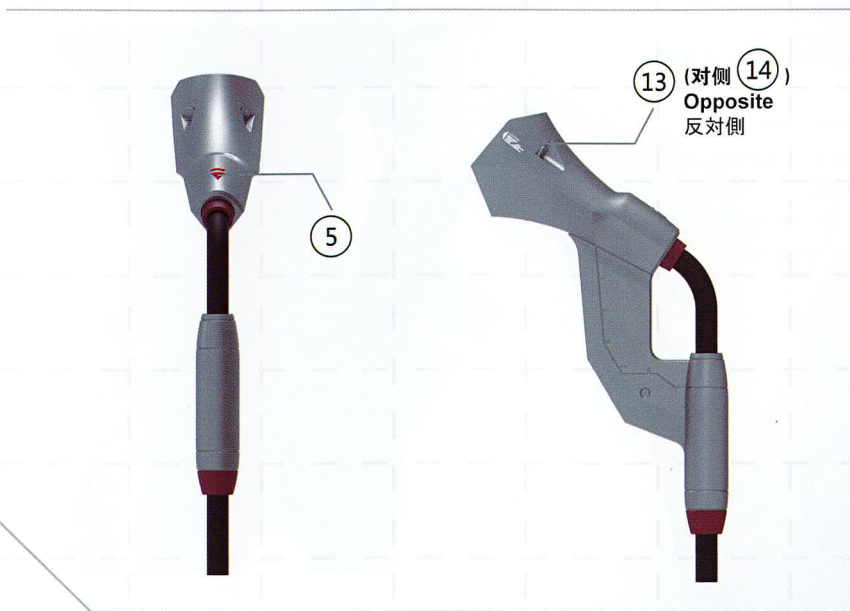
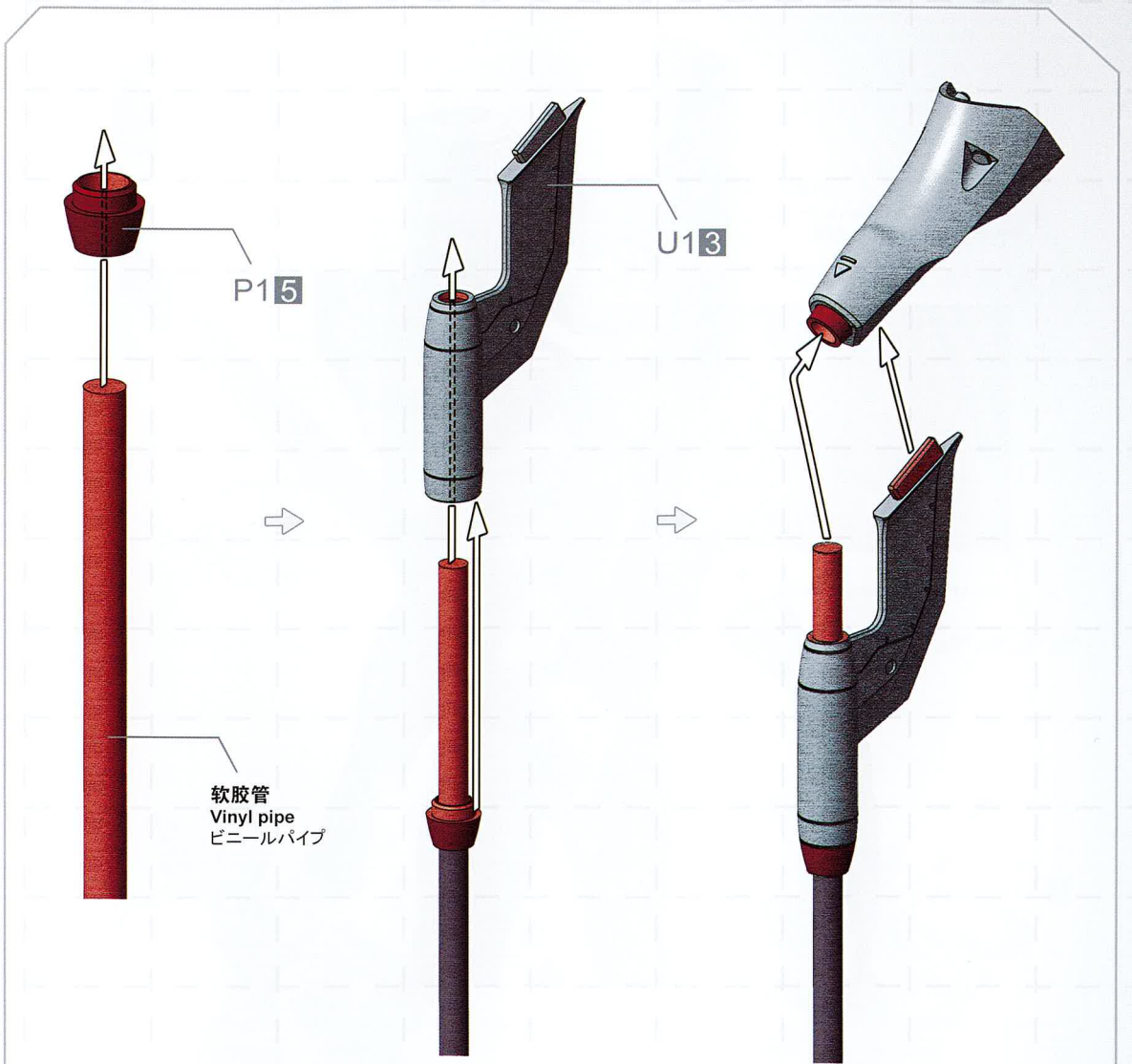

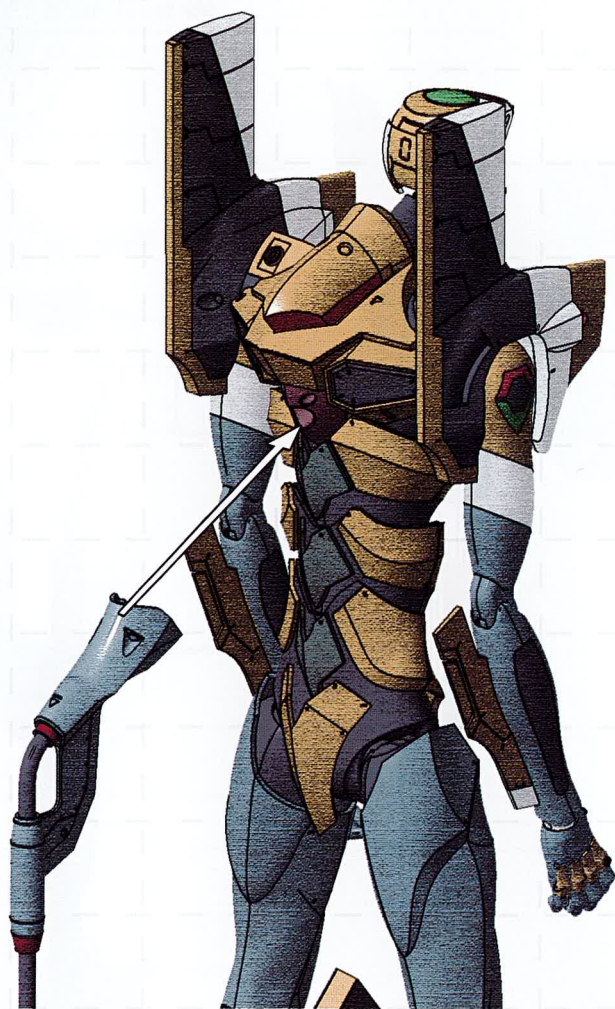

可利用脐带缆线插头撬开 P18 打开电池盒，更换电池。

You can use the Umbilical Cable plug to unclench P18 to open the battery holder and change batteries.

電池を交換する際は、アンビリカルケーブルを用いて P18 を引き抜いてください。

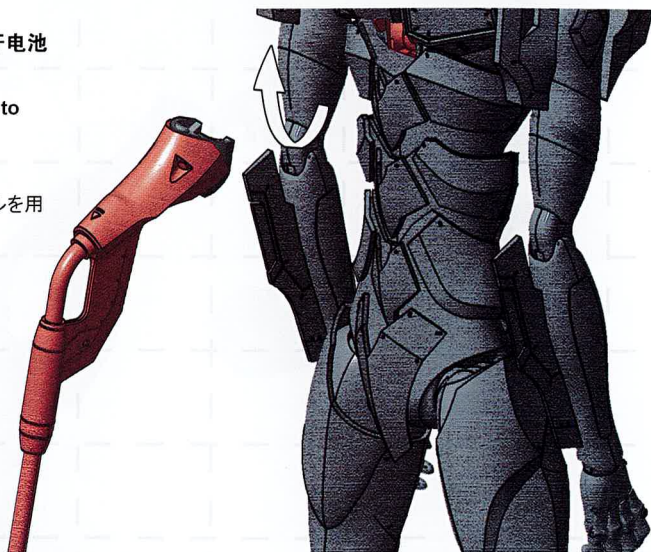

插入栓
Entry Plug
エントリープラグ

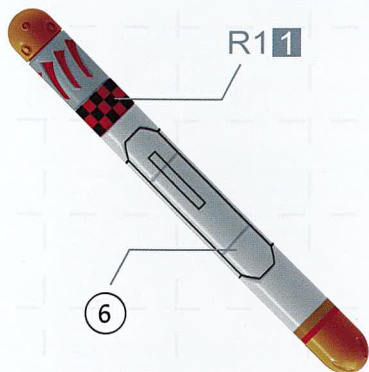

放进插入栓进行灯组开关操作。
Insert the Entry Plug to turn on/off the lights.
エントリープラグの着脱により、照明のON/OFFが可能です。



*图片效果仅供参考。
The images are for illustrative purposes only.
画像はイメージです。

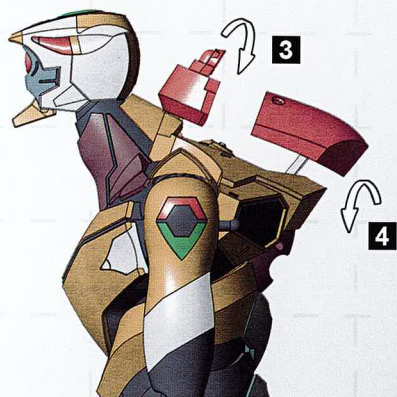
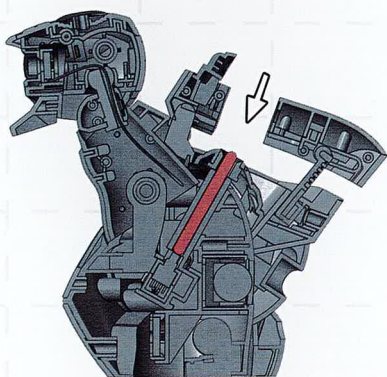
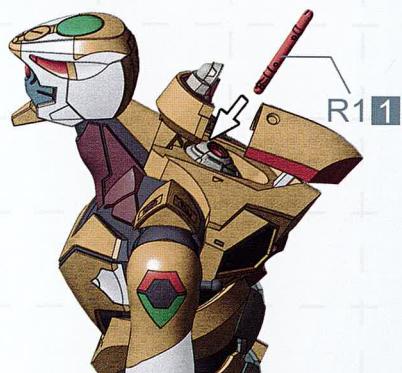
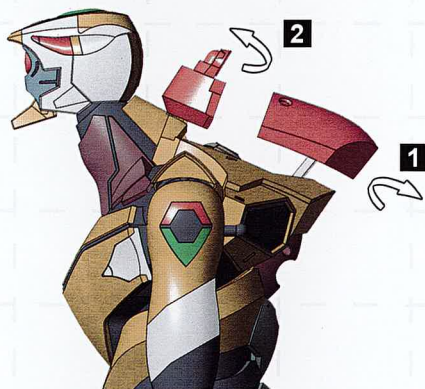

手型使用
Hand options
手首の使用

L 左手 | Left hand | 左手

R 右手 | Right hand | 右手

*图片效果仅供参考。
The images are for illustrative purposes only.
画像はイメージです。



MECHA-003L EVA専用拘束兼移动式输送台需另外购买。
The MECHA-003L Evangelion Restraint/Transport Platform is sold separately.
MECHA-003L エヴァンゲリオン専用拘束兼移动式射出台は別売りです。

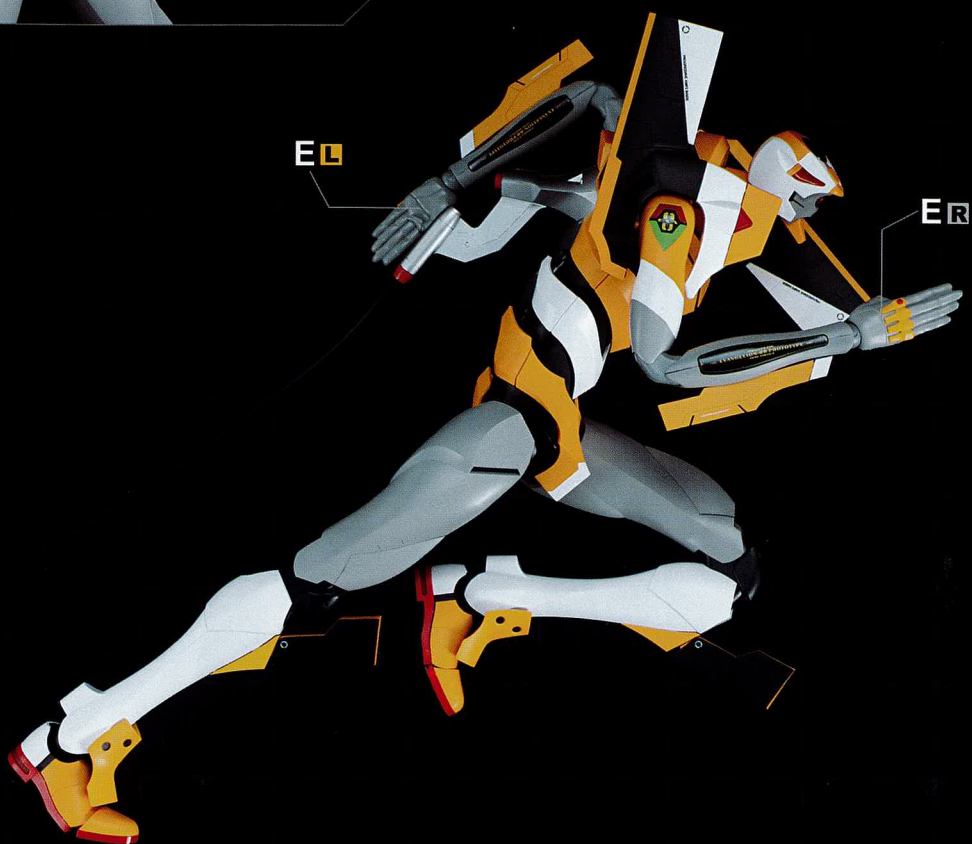

水貼指示
Decal Application
水転写デカール指示

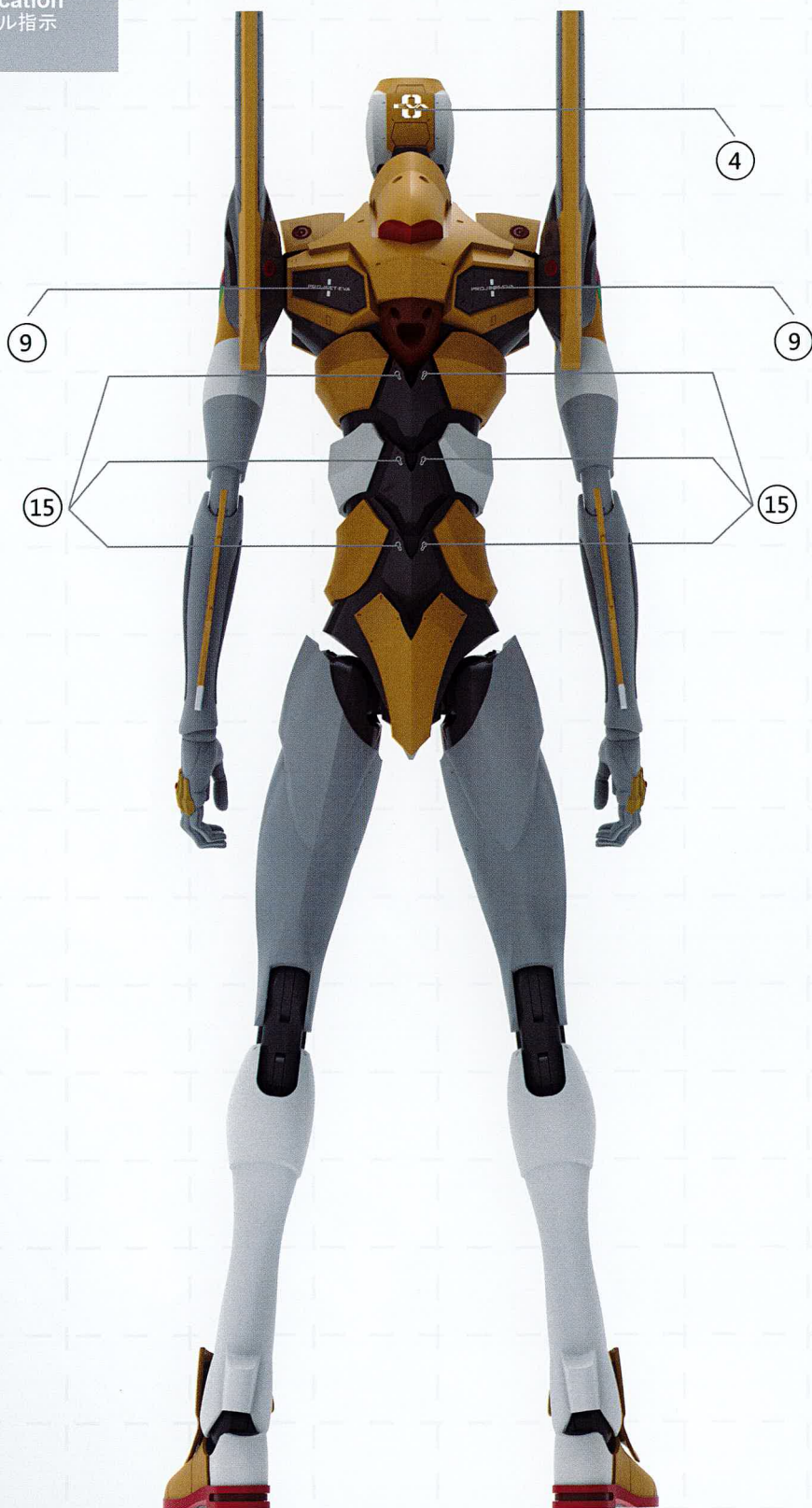

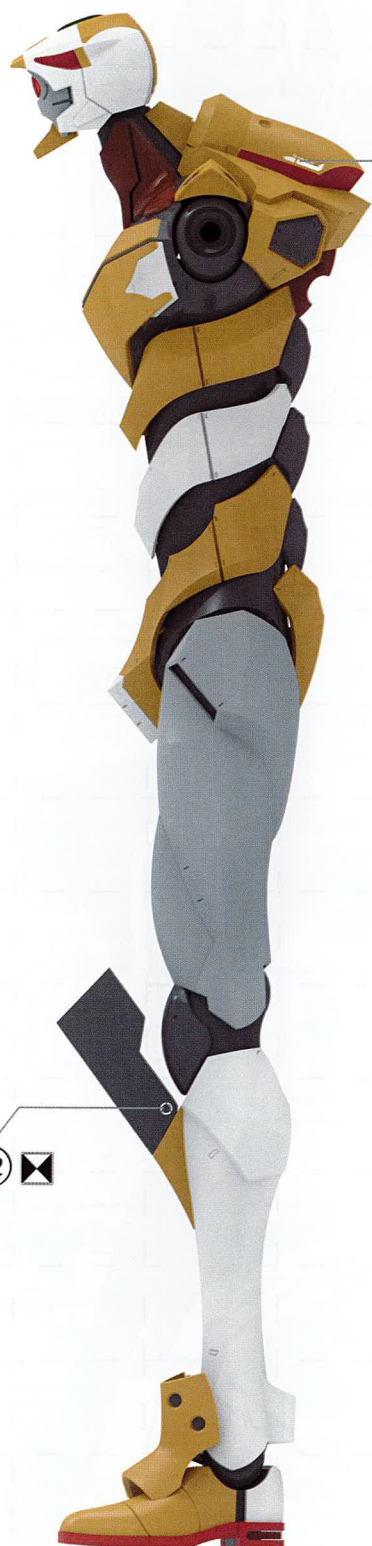

8 (对侧 7)
Opposite
反对侧

22

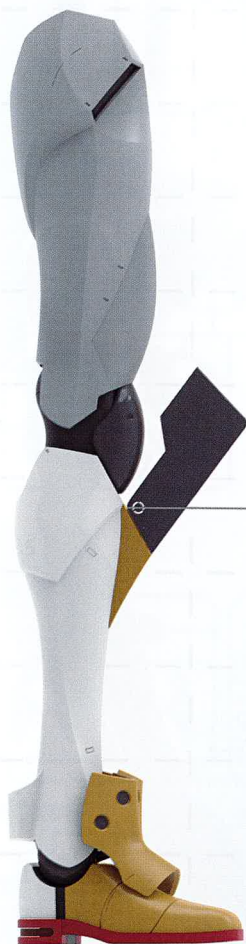

22



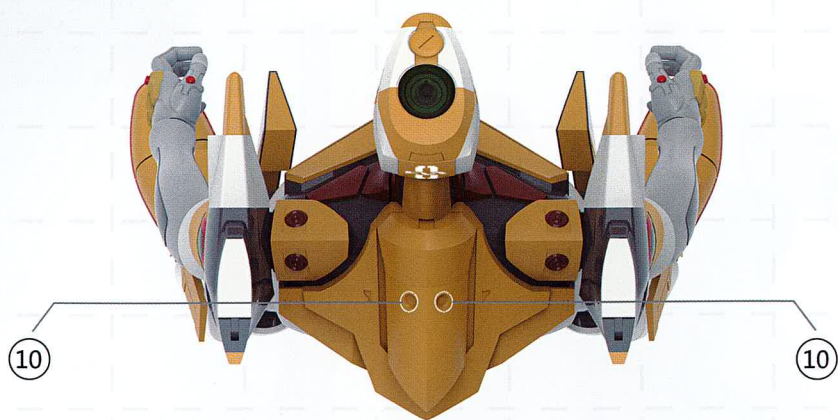

左手臂外側
Outside of left arm
左腕の外側

左手臂内側
Inside of left arm
左腕の内側

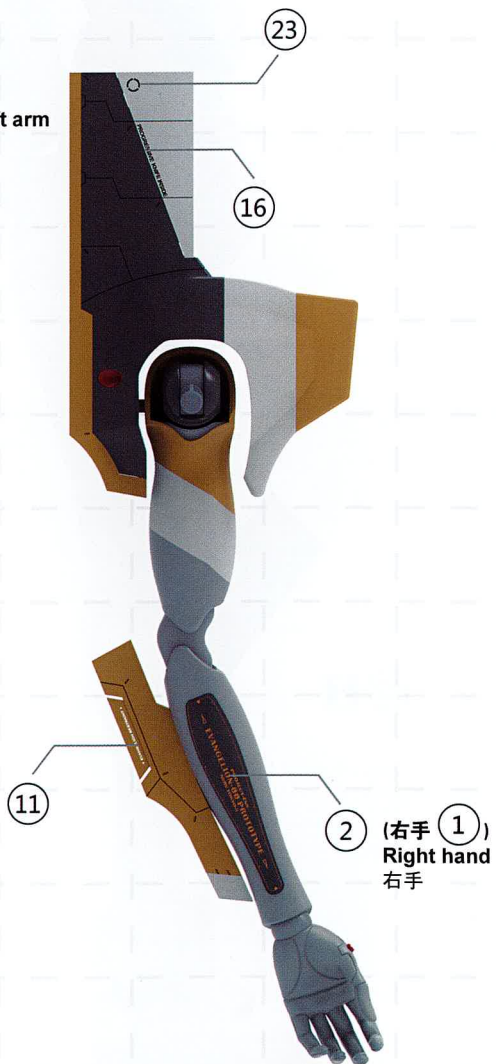
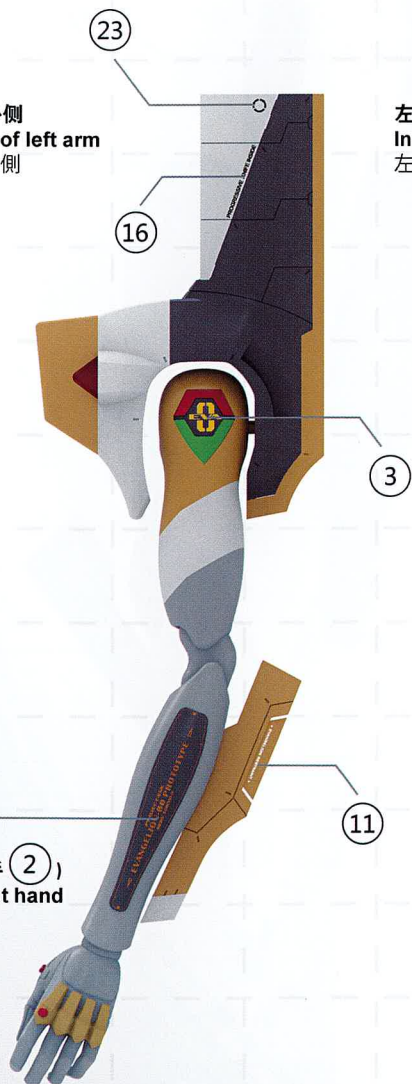

零件图
Parts
部品図

□ 不使用零件
Parts not needed
使用しないパーツ

A Parts

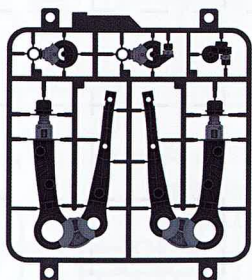

C Parts

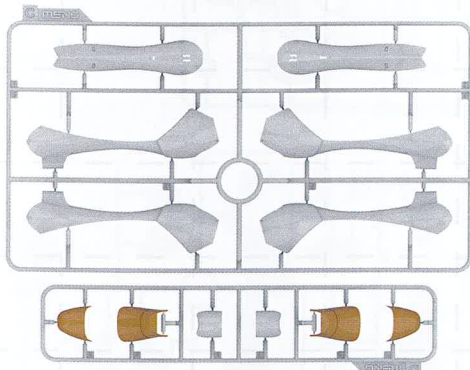

H6 Parts

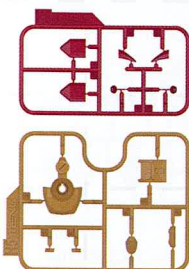

H5 Parts

F1 Parts

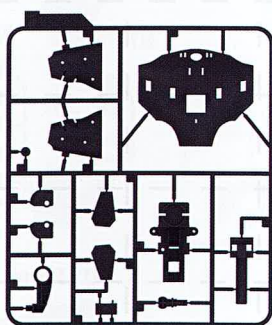

H2 Parts

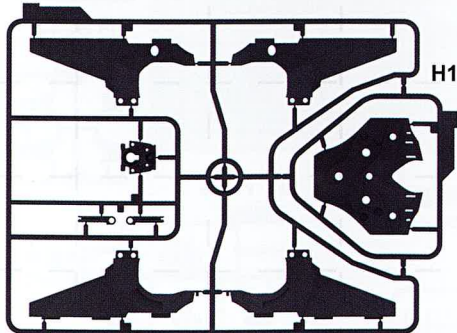

H1 Parts

B Parts

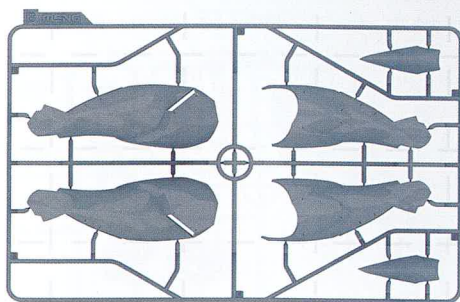

E1 Parts

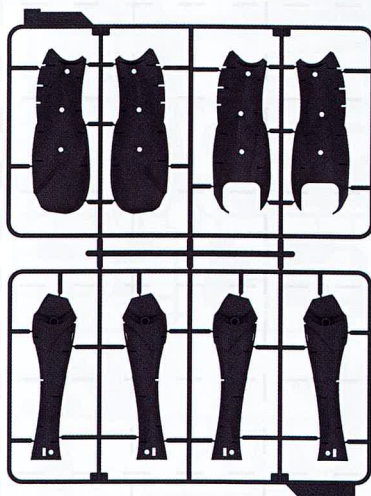

G1 Parts

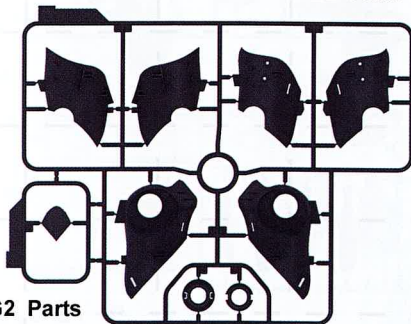

G2 Parts

E2 Parts

G4 Parts

G5 Parts

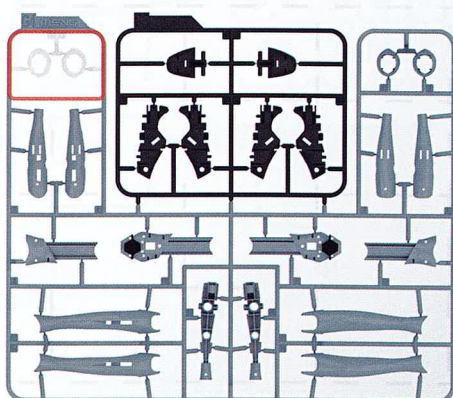

H3 Parts

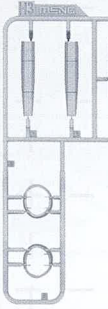

H4 Parts

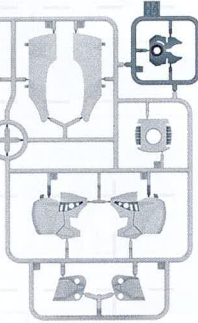

H9 Parts

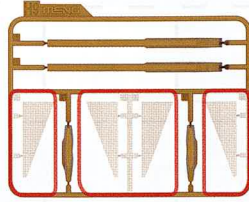

H7 Parts

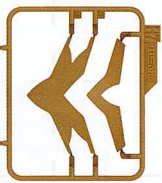

J1 Parts X2

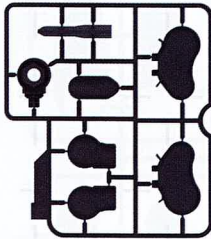

J2 Parts X2

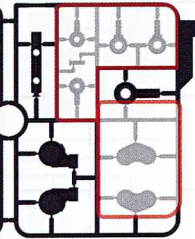

K2 Parts X2

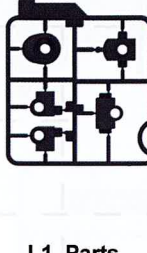

K1 Parts X2

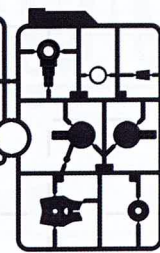

K3 Parts X2



M1 Parts

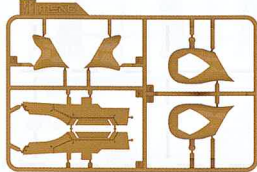

N2 Parts

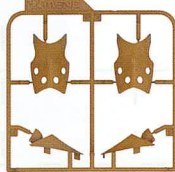

L1 Parts

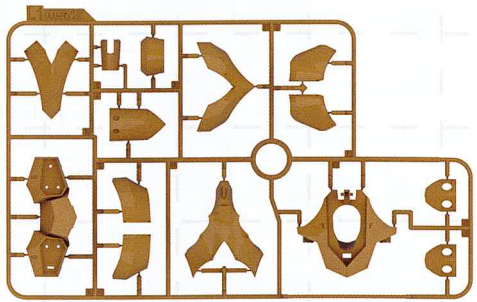

N3 Parts

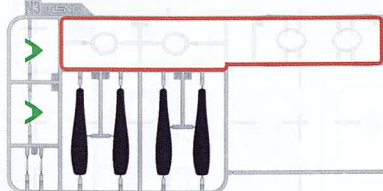

N1 Parts

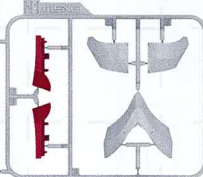

N7 Parts



X1 Parts

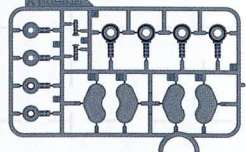

P1 Parts

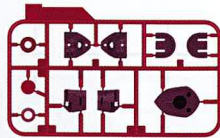

Q1 Parts

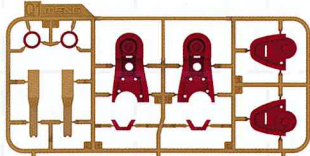

U1 Parts

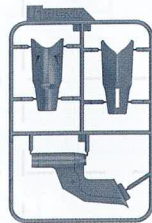

U3 Parts

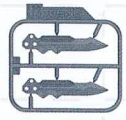

T2 Parts



T1 Parts



U2 Parts

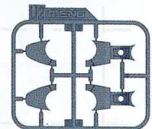

R1 Parts

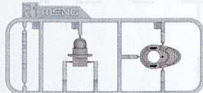

R2 Parts



Q2 Parts

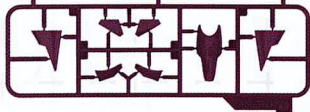

S1 Parts

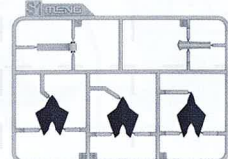

V Parts

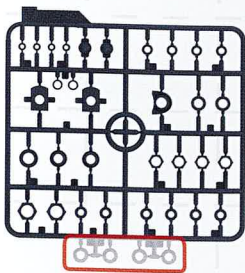

W Parts

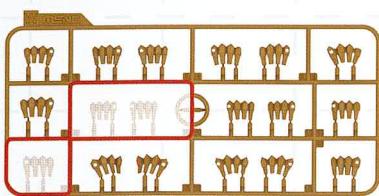

Z3 Parts



Z4 Parts



Z5 Parts



Z1 Parts

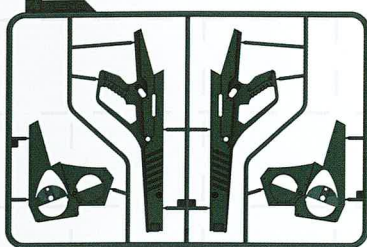

Z2 Parts

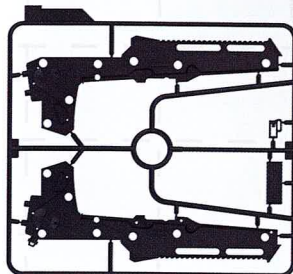

螺丝 X4
Screw
ネジ



弹簧
Spring
スプリング



A-R



C-R



E-R



F-R



G-R



A-L



C-L



E-L



F-L



G-L



H-R



H-L



J-R



J-L



B-R



水贴纸
Decal
水転写デカール

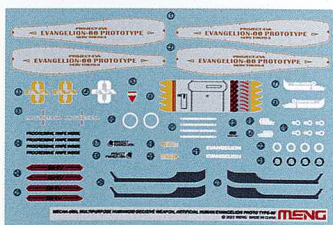

软胶管
Vinyl pipe
ビニールパイプ



螺丝刀
Screwdriver
ドライバー



电路A
Circuit A
回路A



电路B
Circuit B
回路B

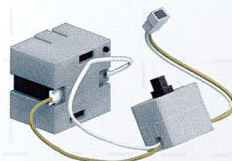



MENG
WWW.MENG-MODEL.COM

MENG
WWW.MENG-MODEL.COM

