

# Revell

NORTH  
AMERICAN

# B-25 MITCHELL

KIT 4585

REVELL, INC. Des Plaines, IL Copyright © 1987 All rights reserved. Made in U.S.A.

4585-0200

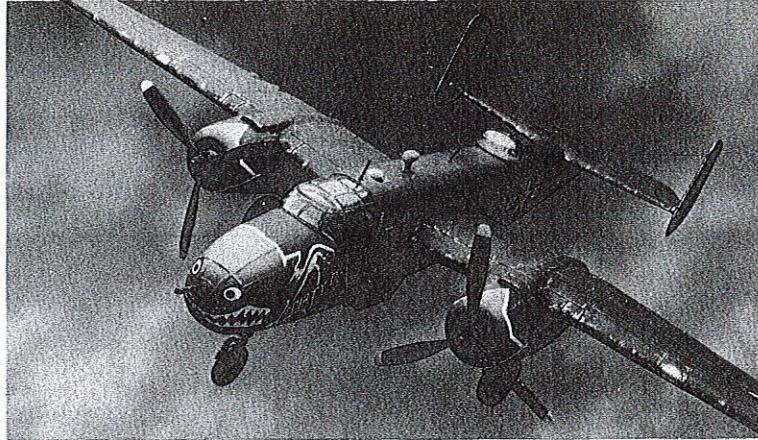

One of the most versatile aircraft used in World War II was the North American B-25 Mitchell medium bomber. Probably best known for its part in the dramatic Doolittle Raid on Tokyo, the B-25 was as adaptable for many roles as it was durable. B-25's used by the 499th Bombardment Squadron, 345th Bombardment Group were among the most colorful planes used in the War.

Assigned to the role of ground attack, Mitchells used by the 499th were modified to carry fixed forward-firing machine guns for low-level strafing.

Four .50 cal. guns were mounted on the sides of the fuselage by the squadron mechanics and many planes had additional guns placed in the glass nose where the bombardier normally rode. Some planes had as many as four guns added to the nose. The glass panels on these planes were painted over with a vicious-looking blue bat design, representing the squadron motto, "The Bats Out Of Hell".

These planes operated from bases in New Guinea late in 1943.

**ENGLISH:** ASSEMBLY DRAWINGS SHOULD BE REVIEWED BEFORE PROCEEDING WITH CONSTRUCTION. A NUMBER IDENTIFIES EACH PLASTIC PART FOR YOUR CONVENIENCE. PAINT SMALL PARTS ON RUNNER BEFORE REMOVING. ALLOW PAINT TO DRY THOROUGHLY BEFORE CONTINUING ASSEMBLY OF KIT. SCRAPE CHROME OR PAINT AT AREA TO BE GLUED. WASH PLASTIC IN MILD DETERGENT SOLUTION. RINSE AND LET AIR DRY FOR BETTER PAINT AND DECAL ADHESION.

**FRANCAIS:** EXAMINER LES SCHEMAS D'ASSEMBLAGE AVANT DE COMMENCER LA CONSTRUCTION. UN NUMERO IDENTIFIE CHAQUE PIECE DE PLASTIQUE POUR PLUS DE FACILITE. PEINDRE LES PETITES PEICES SUR LE SUPPORT AVANT DE LES ENLEVER. LAISSER LA PEINTURE SECHER COMPLETEMENT AVANT DE CONTINUER L'ASSEMBLAGE

DU KIT. GRATTER LE CHROME OU LA PEINTURE SUR LES SURFACE A COLLER. LAVER LE PLASTIQUE DANS UNE SOLUTION DE DETERGENT LEGERE, RINCER ET LAISSER SECHER A L'AIR POUR UNE MEILLEURE ADHERENCE DE LA PEINTURE ET DES DECALS.

**ESPAÑOL:** DIBUJOS DE ENSAMBLAJE DEBEN SER REPASADOS ANTES DE SEGUIR CON LA CONSTRUCCION. UN NUMERO IDENTIFICA CADA PARTE DEL PLASTICO PARA SU CONVENIENCIA. PINTA PARTES PEQUENAS DEL KIT ANTES DE QUITARLAS. DEJE SECAR BIEN LA PINTURA ANTES DE SEGUIR EL ENSAMBLAJE. RASPE EL CROMO O LA PINTURA DEL SITIO ANTES DE SER PEGADO. LAVE EL PLASTICO EN UNA SOLUCION SUAVE DETERGENTE, ENJUAGUE, Y DEJE SECAR EN EL AIRE PARA MEJOR ADHESION DE LA PINTURA Y CALCOMANIA.



GLUE  
COLLE  
PEGA



NO GLUE REQUIRED  
LA COLLE N'EST PAS NECESSAIRE  
NO NECESITA PEGA



DO IT THIS MANY TIMES  
LE FAIRE CE NOMBRE DE FOIS  
HAGALO ESTA CANTIDAD DE VECES



OPTIONAL  
FACULTATIF  
OPCIONAL



APPLY DECALS  
COLLER LES DECALCOMANIES  
APLICAR CALCAS



SHOWN ASSEMBLED  
VU ASSEMBLE  
MOSTRADO ARMADO



DARK OLIVE  
OLIVE FONCE  
OLIVA OSCURO



CLEAR  
TRANSPARENT  
TRANSPARENTE

<b>A</b>	MATT FLESH	CHAIR MAT	PIEL MATE
<b>B</b>	MATT BLACK	NOIR MAT	NEGRO MATE
<b>C</b>	CHROMATE GREEN	VERT CHROMATE	VERDE CROMATO
<b>D</b>	MATT OLIVE GREEN	VERT OLIVE MAT	VERDE OLIVA MATE

<b>E</b>	MATT GRAY	GRIS MAT	GRIS MATE
<b>F</b>	SILVER	ARGENT MAT	PLATA MATE
<b>G</b>	YELLOW	JAUNE	AMARILLO
<b>H</b>	WHITE	BLANC	BLANCO

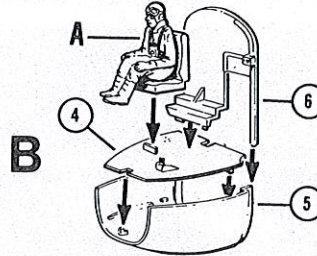
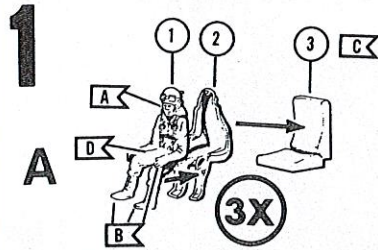

- 1 CREW FIGURE — FRONT HALF (3 PARTS)
- 2 CREW FIGURE — BACK HALF (3 PARTS)
- 3 SEAT (3 PARTS)
- 4 FLOOR — NOSE SECTION
- 5 FUSELAGE NOSE SECTION
- 6 BULKHEAD — NOSE SECTION

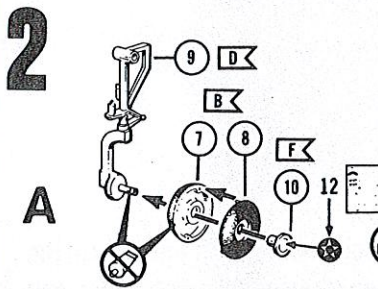

- 7 NOSE WHEEL — RIGHT HALF
- 8 NOSE WHEEL — LEFT HALF
- 9 NOSE STRUT

- 10 WHEEL HUB
- 11 MAIN GEAR STRUT — RIGHT
- 12 HINGE (2 PARTS)

- 13 BRACE (2 PARTS)
- 14 MAIN GEAR STRUT — LEFT

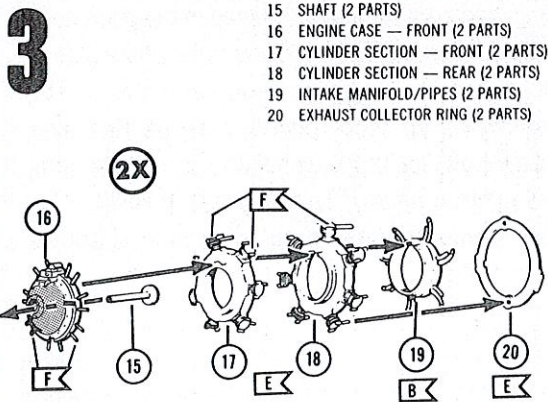
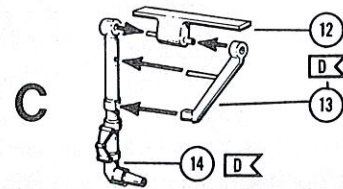
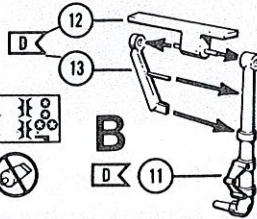

- 15 SHAFT (2 PARTS)
- 16 ENGINE CASE — FRONT (2 PARTS)
- 17 CYLINDER SECTION — FRONT (2 PARTS)
- 18 CYLINDER SECTION — REAR (2 PARTS)
- 19 INTAKE MANIFOLD/PIPES (2 PARTS)
- 20 EXHAUST COLLECTOR RING (2 PARTS)

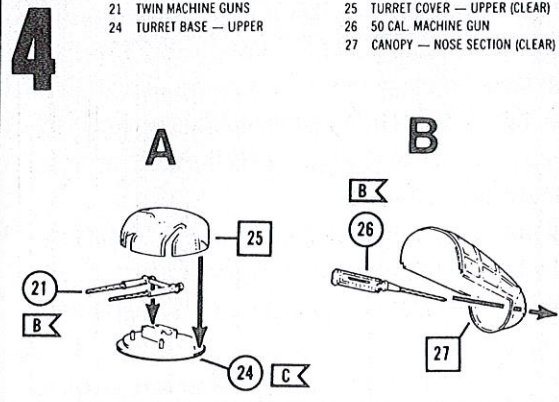

- 21 TWIN MACHINE GUNS
- 24 TURRET BASE — UPPER

- 25 TURRET COVER — UPPER (CLEAR)
- 26 50 CAL MACHINE GUN
- 27 CANOPY — NOSE SECTION (CLEAR)

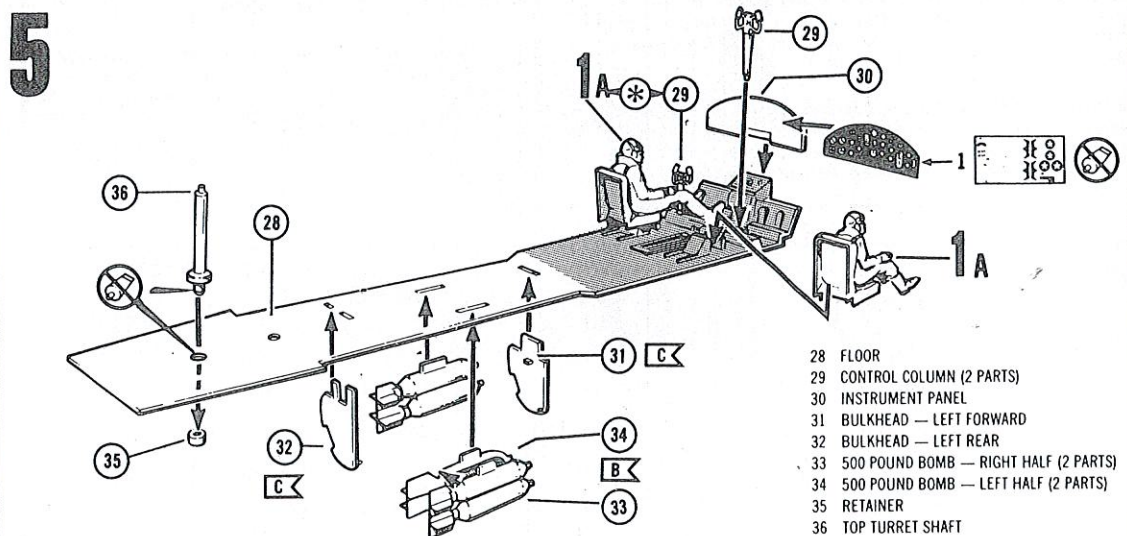

- 28 FLOOR
- 29 CONTROL COLUMN (2 PARTS)
- 30 INSTRUMENT PANEL
- 31 BULKHEAD — LEFT FORWARD
- 32 BULKHEAD — LEFT REAR
- 33 500 POUND BOMB — RIGHT HALF (2 PARTS)
- 34 500 POUND BOMB — LEFT HALF (2 PARTS)
- 35 RETAINER
- 36 TOP TURRET SHAFT

# 6

- 37 STORAGE PANEL — LOWER GUNS
- 38 FUSELAGE — LEFT HALF
- 39 BOMB BAY DOOR — LEFT

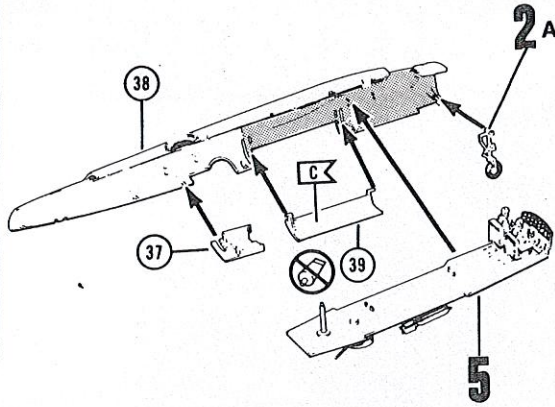

# 7

- 40 BULKHEAD — RIGHT FORWARD
- 41 FUSELAGE — RIGHT HALF
- 42 BOMB BAY DOOR — RIGHT
- 43 BULKHEAD — RIGHT REAR

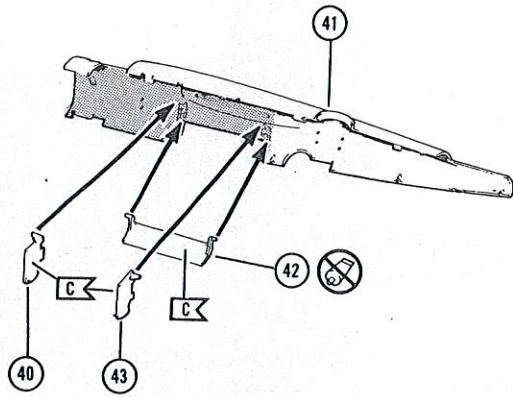

# 8

- 44 TURRET COVER — LOWER
- 45 GUN STORAGE FAIRING

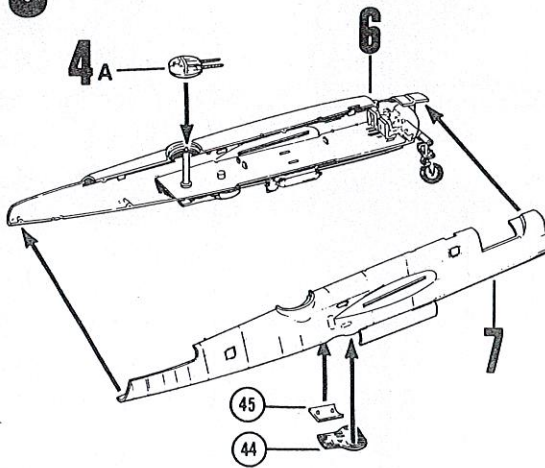

# 9

- 46A OBSERVATION DOME (CLEAR)
- 47 SMALL SQUARE WINDOW (CLEAR) (2 PARTS)
- 48 OVAL WINDOW (CLEAR) (2 PARTS)
- 49 LARGE RECTANGULAR WINDOW (CLEAR) (2 PARTS)

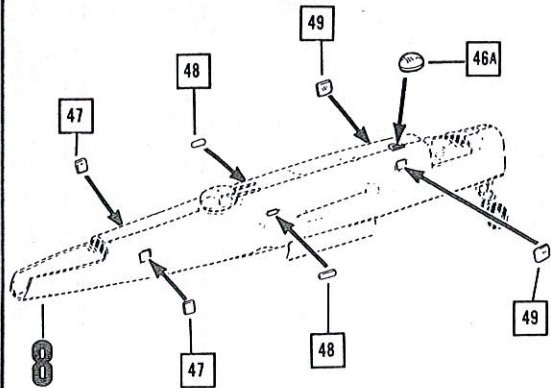

# 10

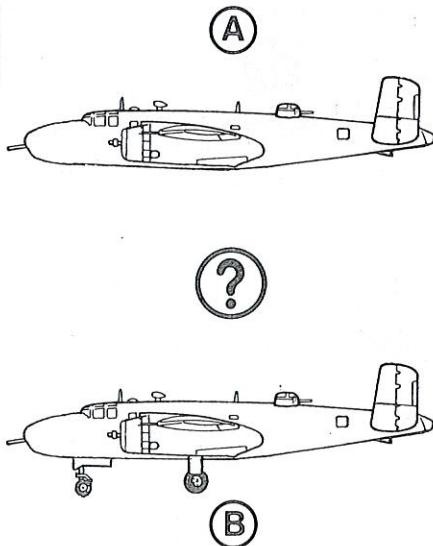

# 11

- 71 NOSE WHEEL DOOR
- 72 MAIN GEAR DOOR — RIGHT
- 73 MAIN GEAR DOOR — LEFT

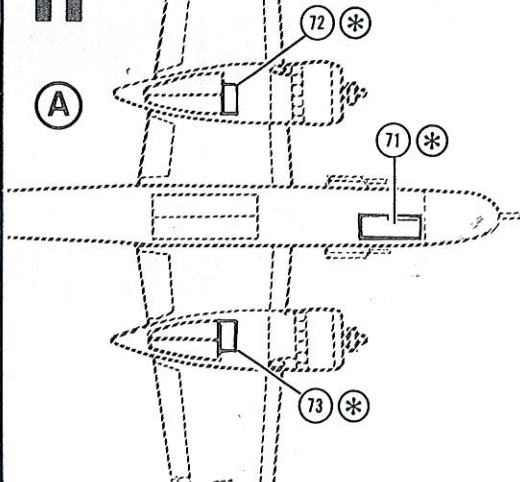

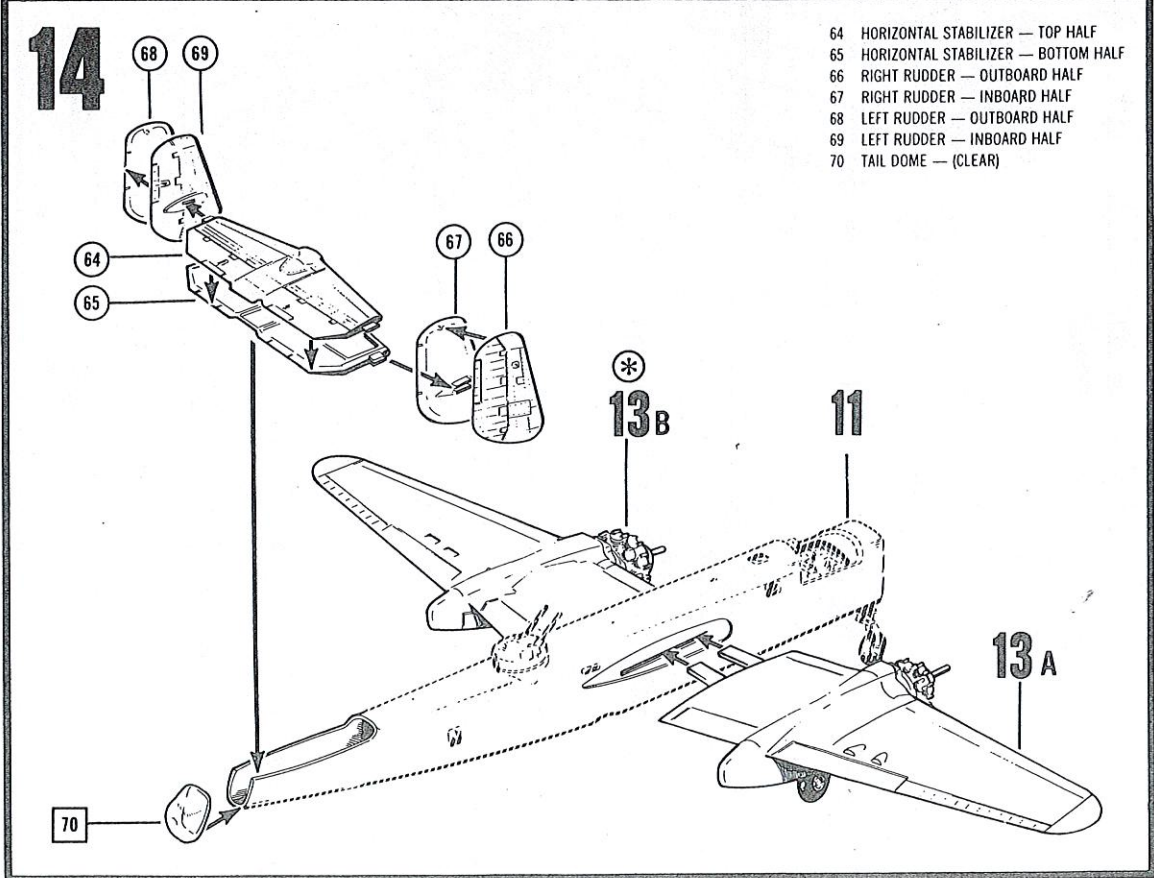
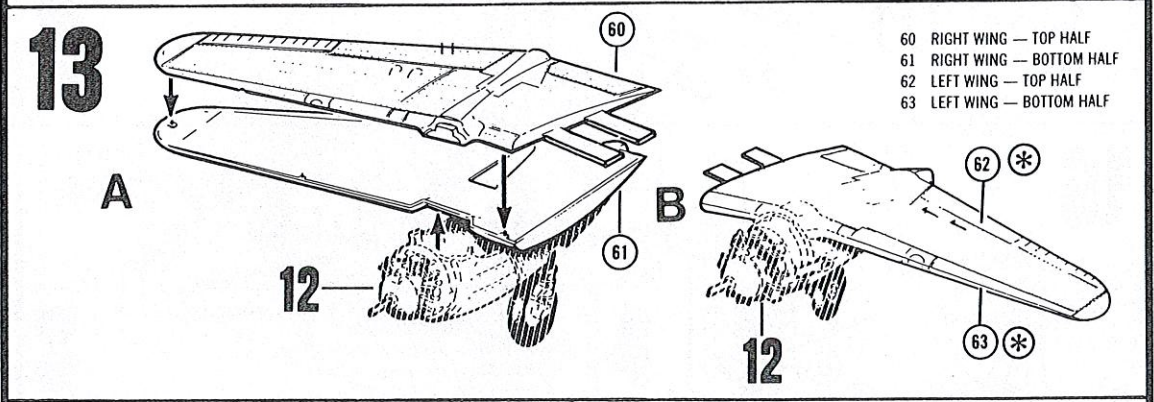
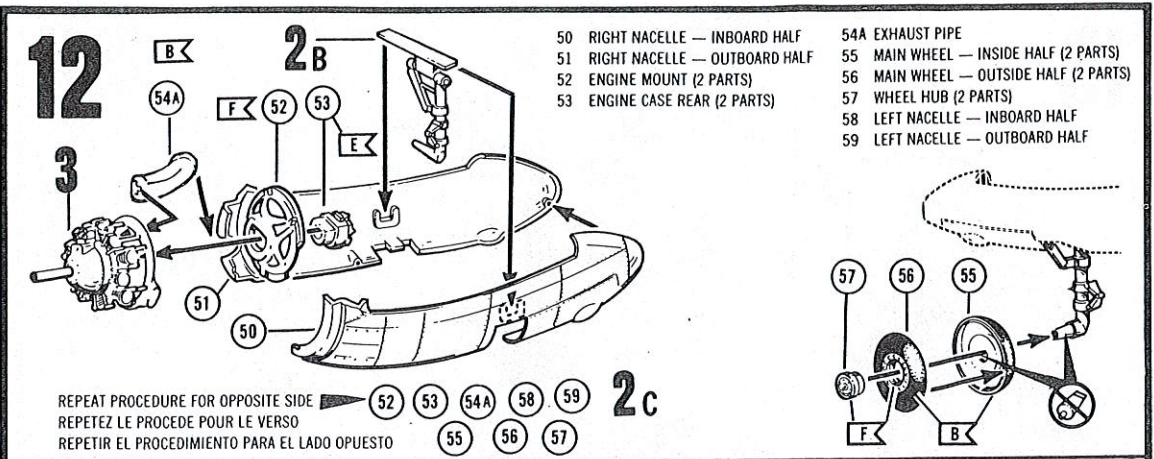

# 15

- 71 NOSE GEAR DOOR
- 72 MAIN GEAR DOOR — RIGHT
- 73 MAIN GEAR DOOR — LEFT
- 74 TAIL SKID
- 83 GUN BLISTER — RIGHT
- 84 GUN BLISTER — LEFT

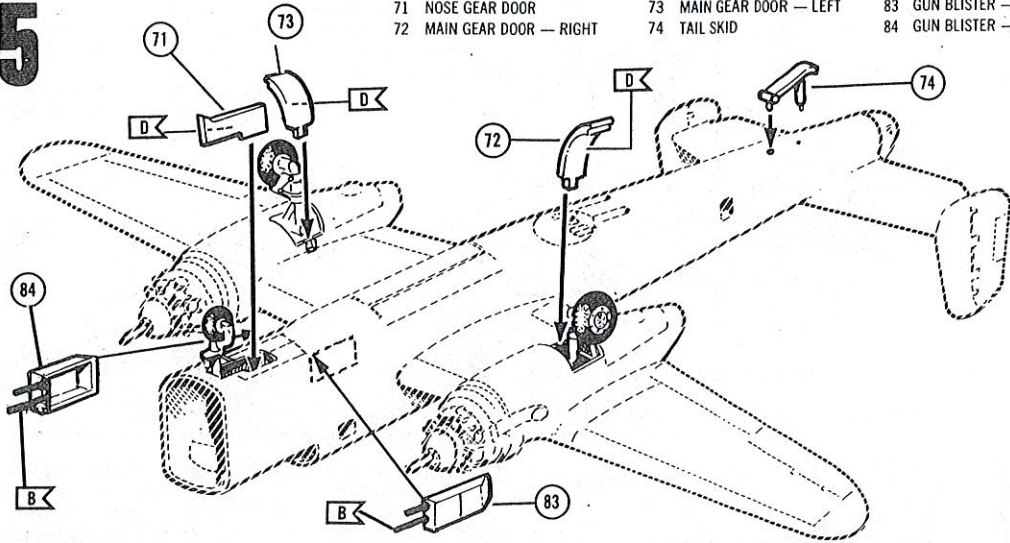

# 16

- 75 COCKPIT CANOPY (CLEAR)
- 81 ENGINE COWLING (2 PARTS)
- 82 PROPELLER (2 PARTS)

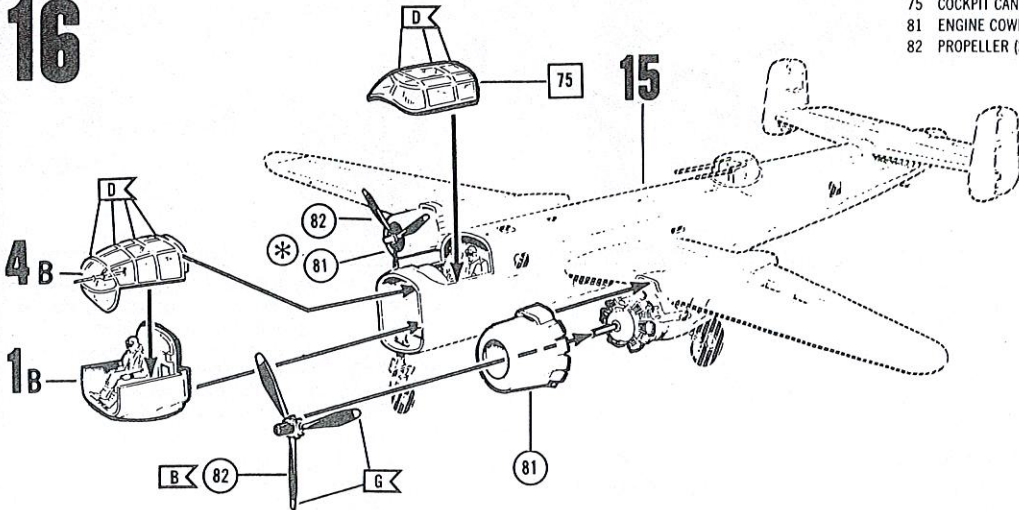

# 17

- 76 PITOT TUBE
- 77 RADIO MAST (2 PARTS)
- 78 LOOP ANTENNA HOUSING
- 79 TAIL STAND YOKE
- 80 TRIPOD

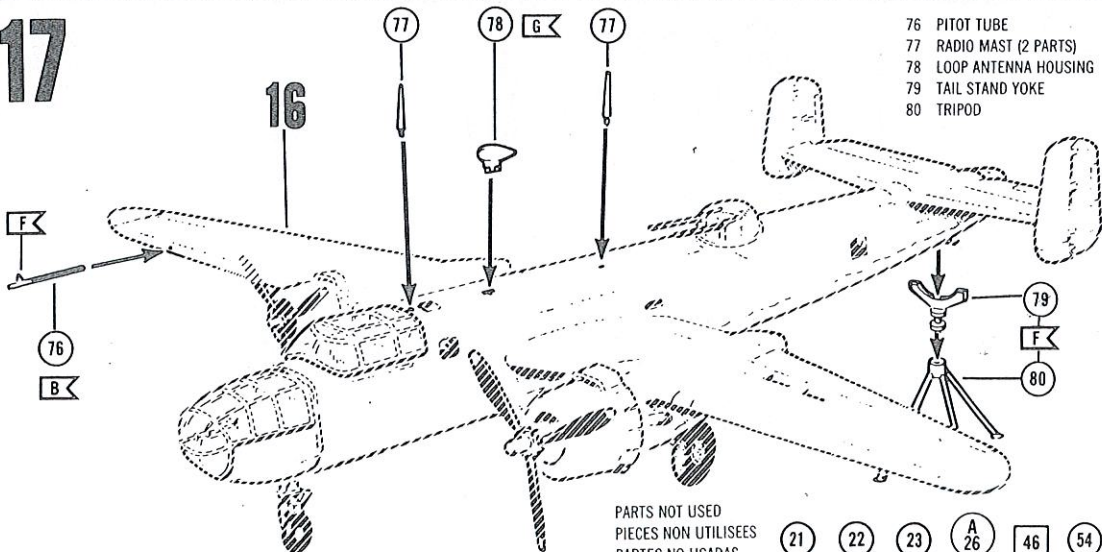

PARTS NOT USED  
PIECES NON UTILISEES  
PARTES NO USADAS

- 21
- 22
- 23
- A 26
- 46
- 54

18

