

F/A-18
A+/B/CF-188

F/A-18A+/B/CF-188

ROYAL CANADIAN AIR FORCE, ROYAL AUSTRALIAN AIR FORCE & SPANISH AIR FORCE
F/A-18A+/B/CF-188 ホーネット / オーストラリア空軍 / スペイン空軍 / カナダ空軍



F/A-18A+/B/CF-188

F/A-18 is a twin-engine supersonic, all-weather carrier-capable multirole fighter jet, designed to dogfight and attack ground targets.

Canada was the first export customer for the Hornet, replacing the CF-104 Starfighter, the CF-101 Voodoo and the CF-116 Freedom Fighter. The Canadian Forces Air Command ordered 98 A models (CF-188A/CF-18A) and 40 B models (CF-188B/CF-18B). The original CF-18 as delivered is largely identical to the F/A-18A and B models.

In 1991, Canada committed 26 CF-18s to the Gulf War, based in Qatar. These aircraft primarily provided Combat Air Patrol duties, and later to perform air strikes on Iraqi ground targets. In 1999, 18 CF-18s were deployed to Aviano AB, Italy, where they participated in both the air-to-ground and air-to-air roles in the former Yugoslavia.

The Royal Australian Air Force purchased 57 F/A-18A fighters and 18 F/A-18B two-seat trainers to replace its Mirage IIIOs. Original differences between the Australian and US Navy's standard F/A-18 were the removed nose wheel tie bar for catapult, addition of a high frequency radio, an Australian fatigue data analysis system, an improved video and voice recorder, and the use of ILS/VOR.

F/A-18 deliveries to the RAAF began in 1984, Australia deployed 4 aircraft to Diego Garcia, in an air defense role, during coalition operations against the Taliban in Afghanistan. In 2003, 75 Squadron deployed 14 F/A-18s to Qatar as part of Operation Falconer.

The Spanish Air Force ordered 60 EF-18A model and 12 EF-18B model Hornets. Delivery of the Spanish version started in 1985. These fighters were upgraded to F-18A+/B+ standard, close to F/A-18C/D.

Spanish Air Force EF-18 Hornets have flown Ground Attack, SEAD, combat air patrol (CAP) combat missions in Bosnia and Kosovo, under NATO command, in Aviano detachment.

CAUTION

- *Read carefully and fully understand the instructions before commencing assembly.
- *Keep out of reach of children. Children must not be allowed to put any parts in their mouths, or pull plastic bag over their heads.
- *When using adhesives and paints, please make sure not to use them in closed room or near the fire.
- *When assembling this kit, tools including knives are used. Extra care should be taken to avoid injury.

WARNING: CONTAIN SMALL PARTS NOT FOR CHILDREN UNDER 14 YEARS OF AGE.



Drill



Remove



2 Set



Bend



Optional



Decal



Super Glue



Fill Hole



No Cement



Be Careful

TOOLS RECOMMENDED

Cement

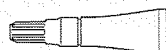

Side Cutter



Modeling Knife

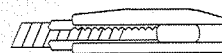

Tweezers

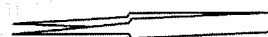

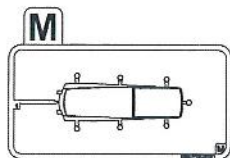
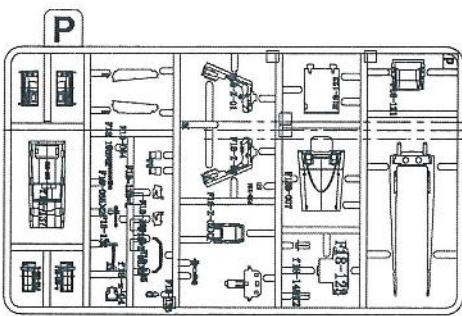
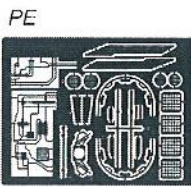
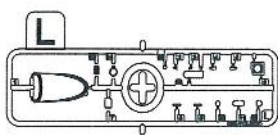
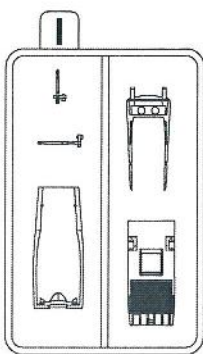
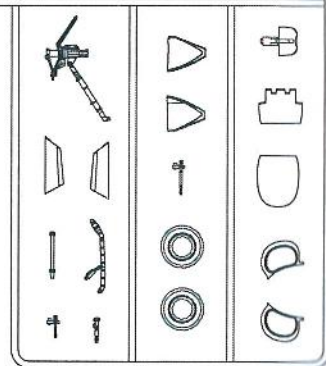
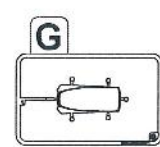
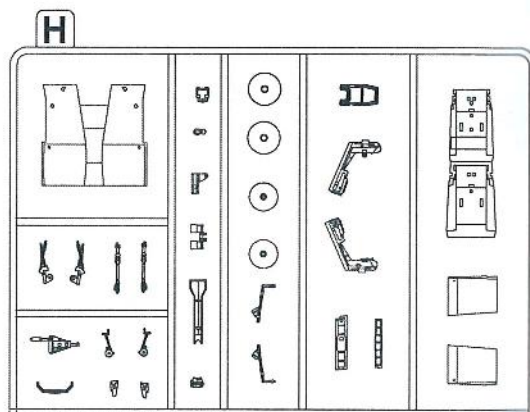
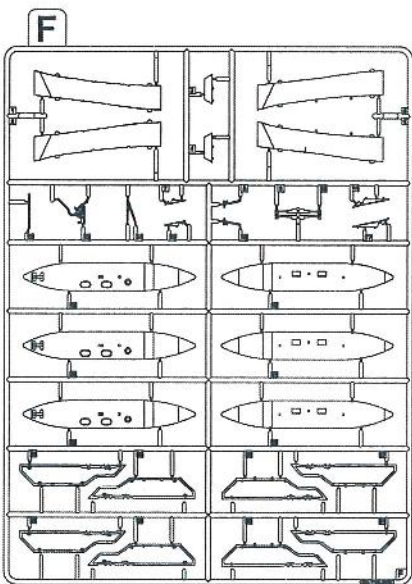
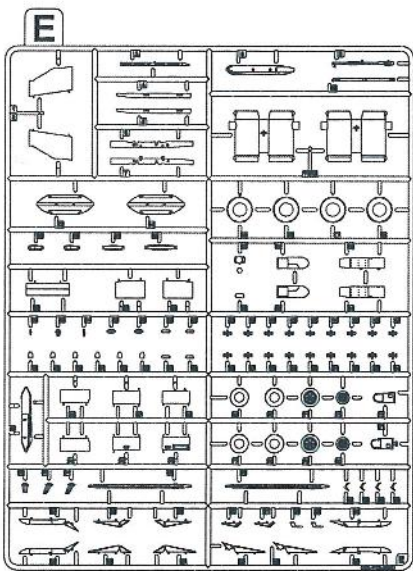
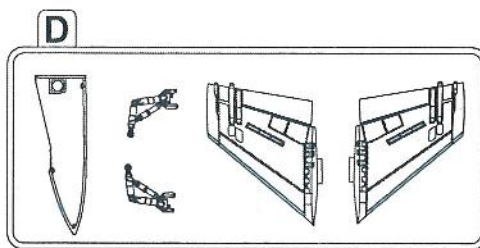
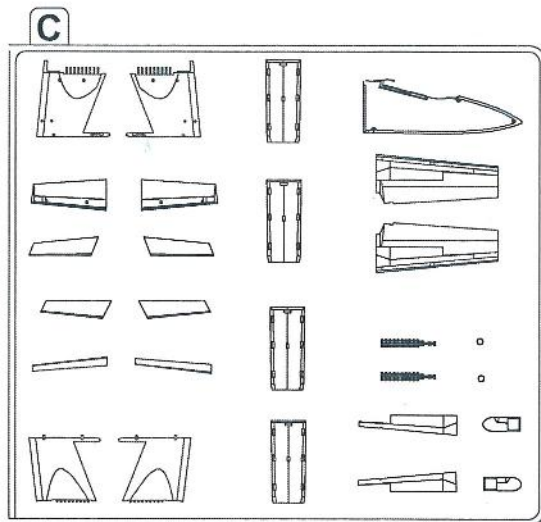
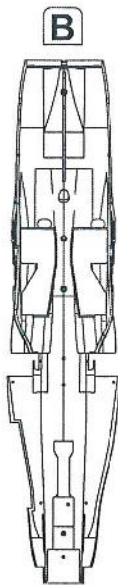
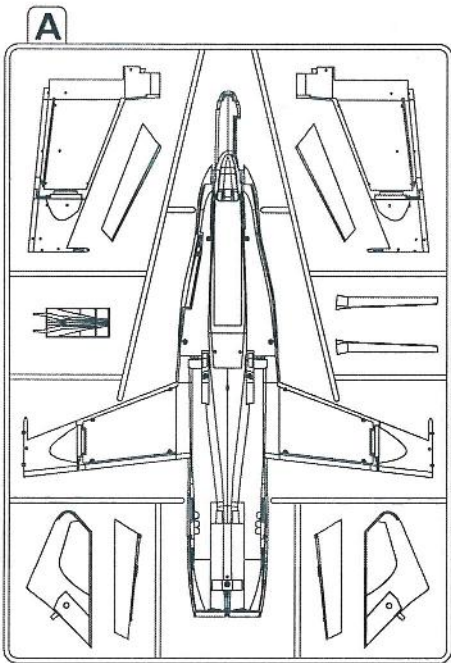

1/48 SCALE AIRCRAFT SERIES NO: K48030

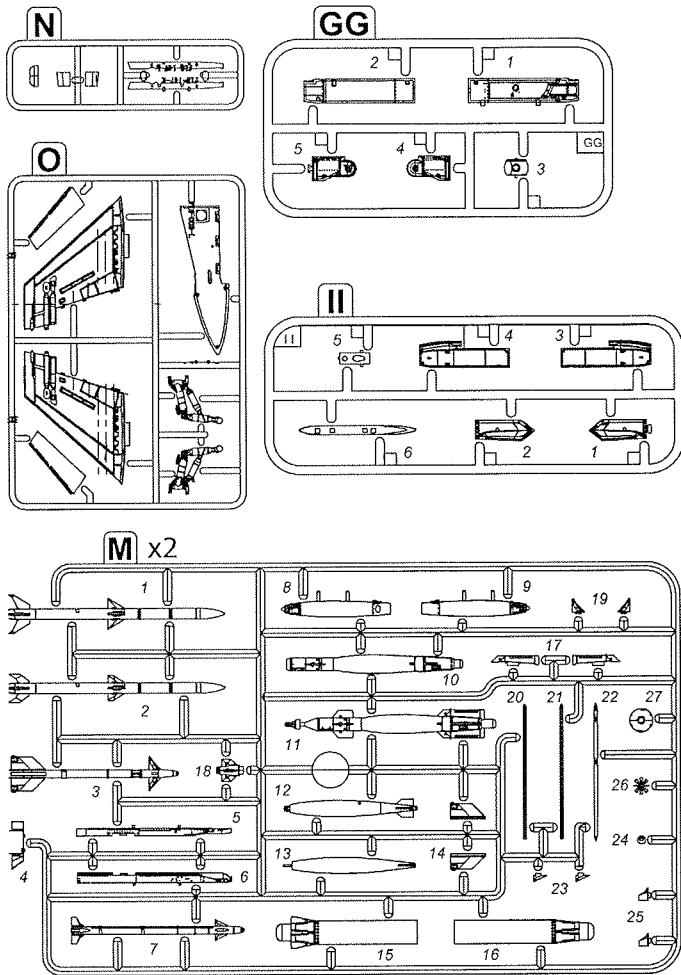

AFTERMARKET SERVICES CARD

When requesting replacement parts, please take or send this form to your local dealer so that the parts required can be correctly identified. Please note that specifications and availability are subject to change without notice.

or visit <http://www.kineticmodel.com> for latest information.

For more information, please contact services@kineticmodel.com

Part Code	K48030	Item	Qty
00-100-021	WEAPON SET (AIM-9x9M,120B/C,GBU-12) PARTS M	M	2
00-100-030	LARTIN POD PARTS GG	GG	1
00-100-032	SNIPER XR POD PARTS II	II	1
00-112-001	1/48 F/A-18 UPPER FUESLAGE A	A	1
00-112-002	1/48 F/A-18 LOWER FUESLAGE B	B	1
00-112-003	1/48 F/A-18 FLAPS C	C	1
00-112-004	1/48 F/A-18 C/D VERTICAL TAIL D	D	1
00-112-005	1/48 F/A-18 WHEEL, PYLONS E	E	1
00-112-006	1/48 F/A-18 FUEL TANKS, PYLON F	F	1
00-112-007	1/48 F/A-18 A/C CANOPY G	G	1
00-112-008	1/48 F/A-18 COCKPIT, LANDING GEAR H	H	1
00-112-009	1/48 F/A-18 A/C PARTS I	I	1
00-112-012	1/48 F/A-18 COMMON CLEAR PARTS L	L	1
00-112-013	1/48 F/A-18 DOUBLE CANOPY M	M	1
00-112-014	1/48 F/A-18 A/B/C/D PYLON ANN. PART N	N	1
00-112-015	1/48 F/A-18 A/B VERTICAL TAIL PART O	O	1
00-112-016	1/48 F/A-18 B/D PARTS P	P	1
01-112-48030	1/48 F/A-18AB+		1
03-112-48030	1/48 F/A-18AB+ MANUAL		1
06-112-48031	1/48 F/A-18A/C	PE	1

The Making of Kinetic Hornet model kit

The 1/48 Hornet kit project cannot be realized without the help from Rick Chin, a well-respected modeler and the owner of Uncle Bill's Hobby in Calgary, Canada. We are so proud to have Rick involved in this project, and so we got the accurate information and numerous photos which enable us made an updated and accurate model possible. With him, we had the tremendous support from Cold Lake ROCAF to ensure us to make an accurate CF-188 model kit as most updated configurations are not known in most documents and online. We are sad that Rick left us in April 2014 and we know he would like all of us enjoy building this model. Besides, we would like to thank you all the contributors, they are Thomas Sime, the commander at that time call sign "Sleepy" and our GIB team.

In memory of our old good friend, we hereby to let everyone knows the "hero" behind the project, which was started in 2008. Thank you, Rick.



Hi Rick, your hornet is here! We deliver it finally!

F/A-18A - Cockpit 1 - 3

1

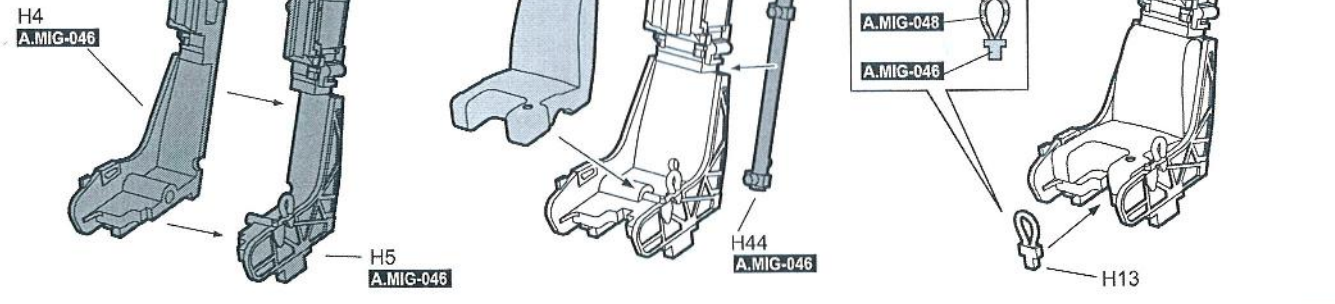

2

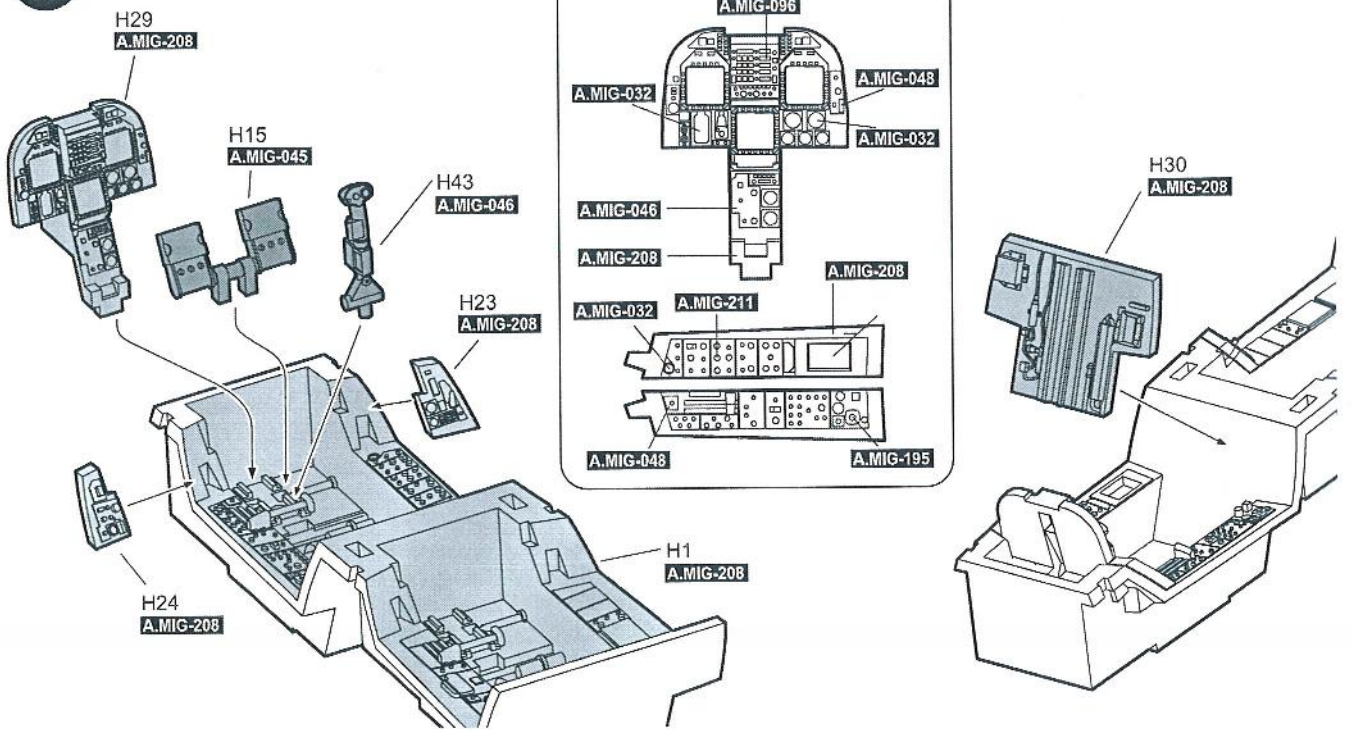

3

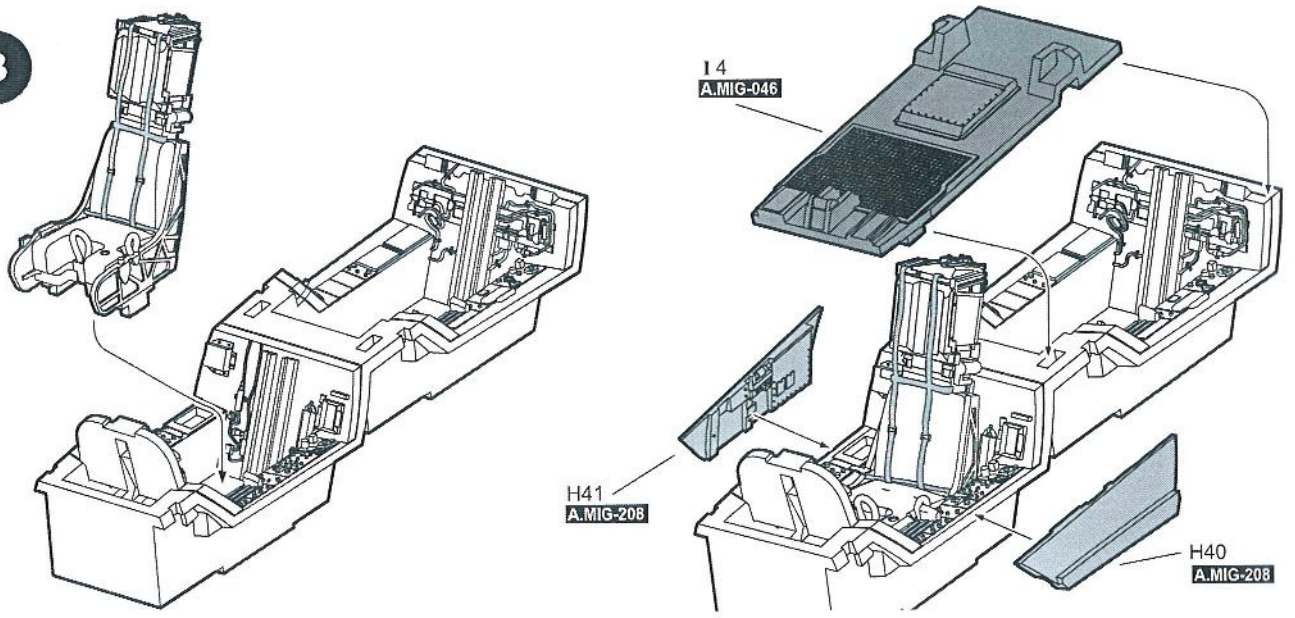

4

P10
A.MIG-046

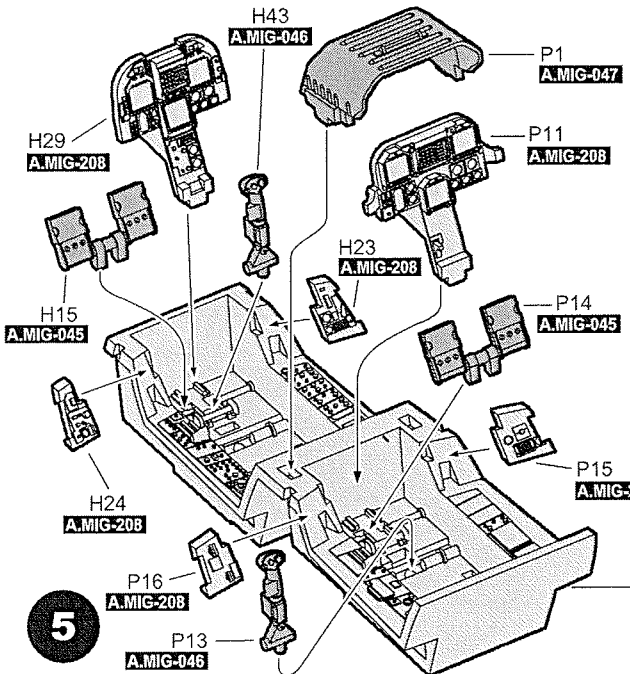
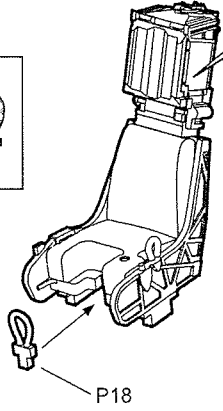
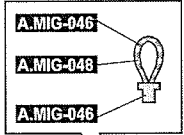
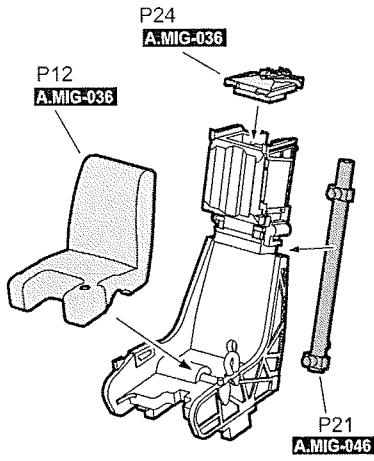
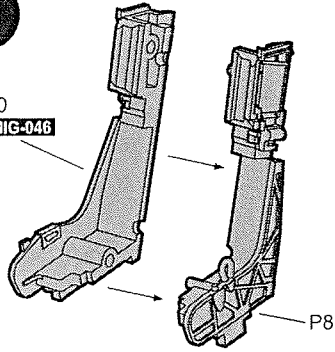

5

Painting Instruction

* Add decal placement. Refer to Page 20 A.MIG-208

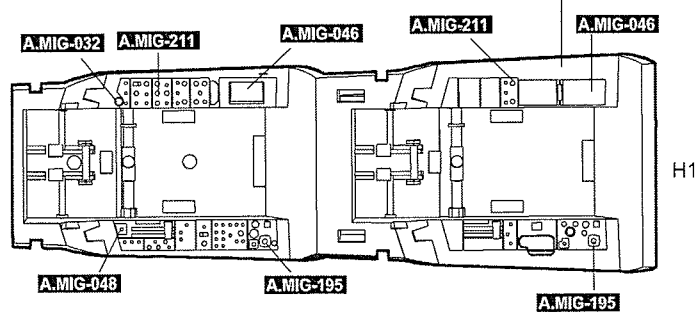

Painting Instruction

* Add decal placement. Refer to Page 20

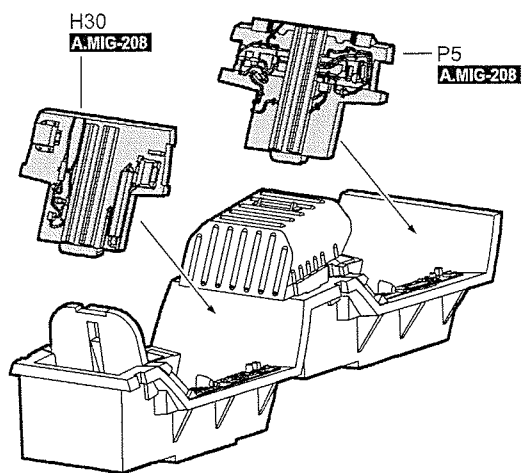
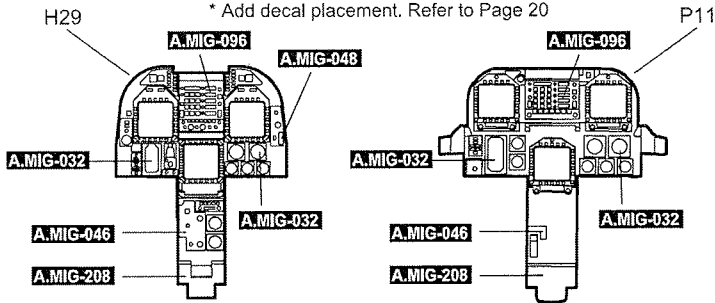

6

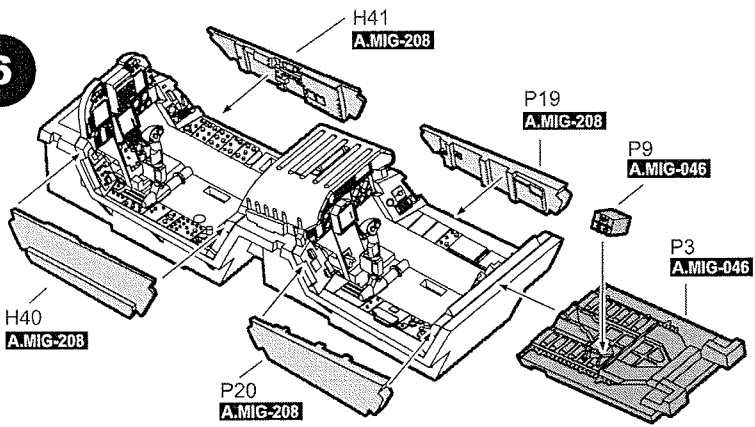

4

1

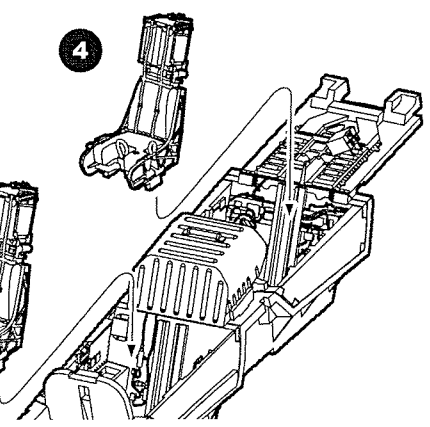

7

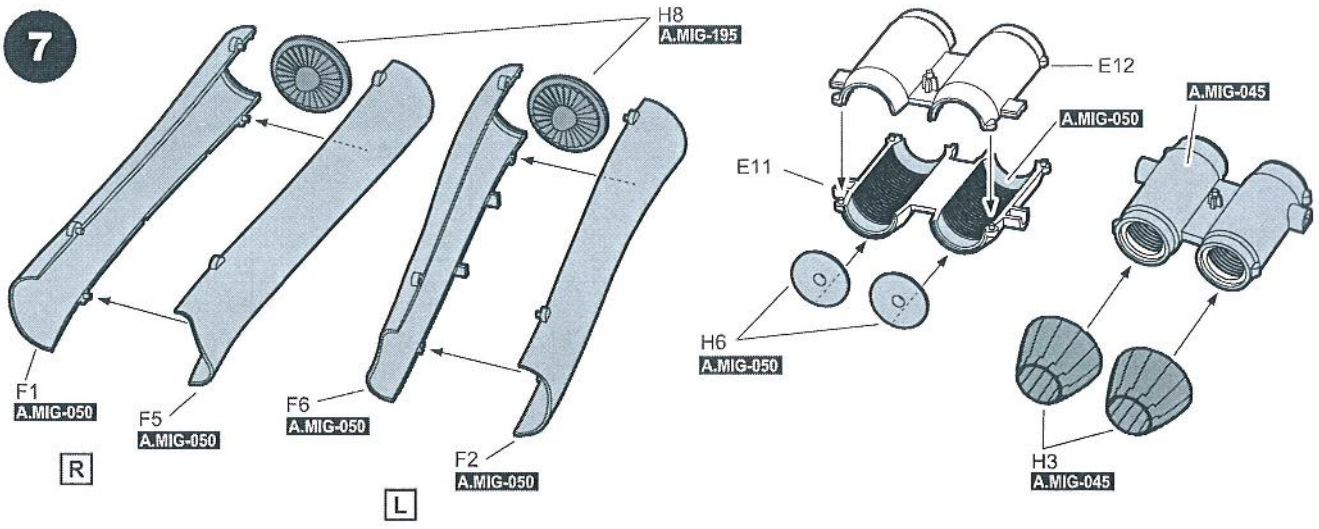

8

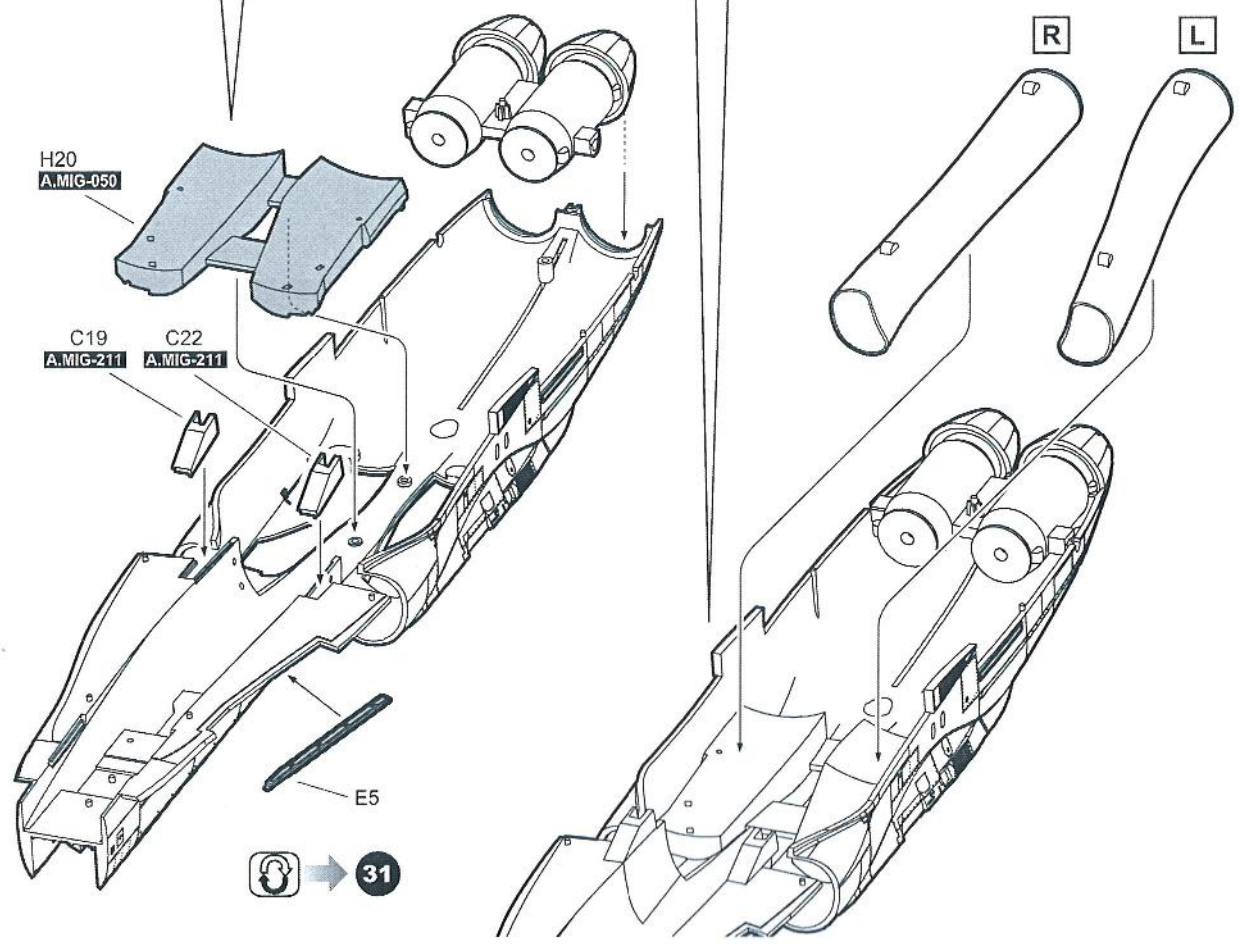
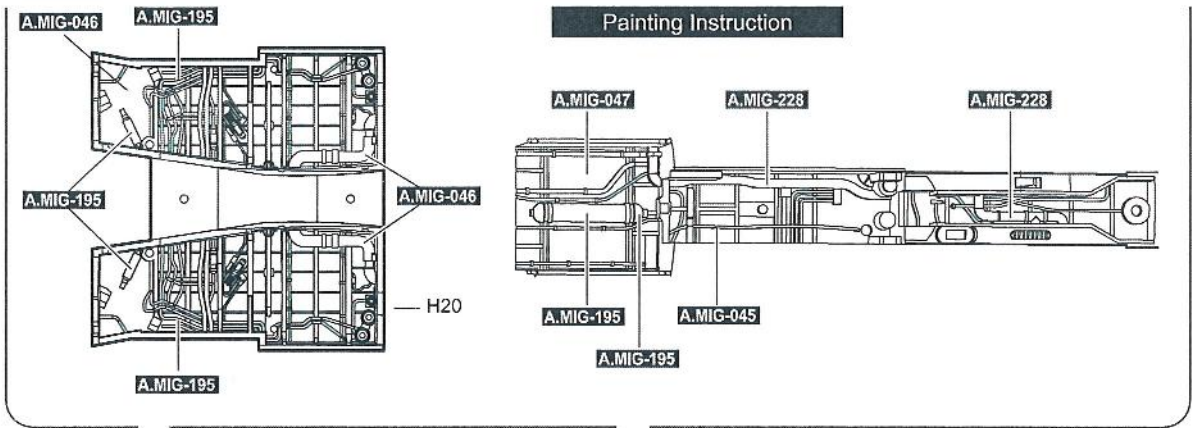

9

Refuelling Probe Open



Refuelling Probe Close

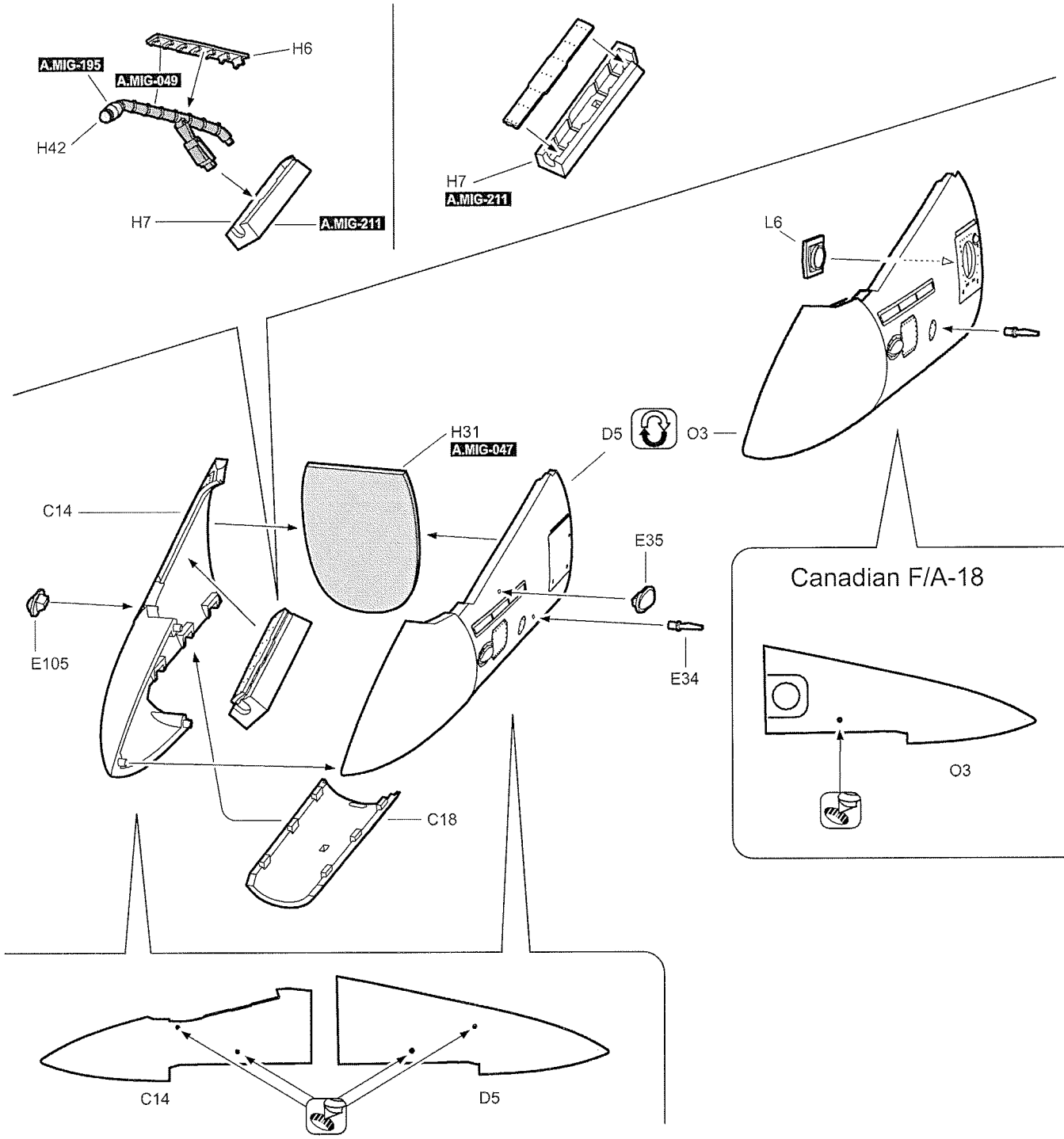

10

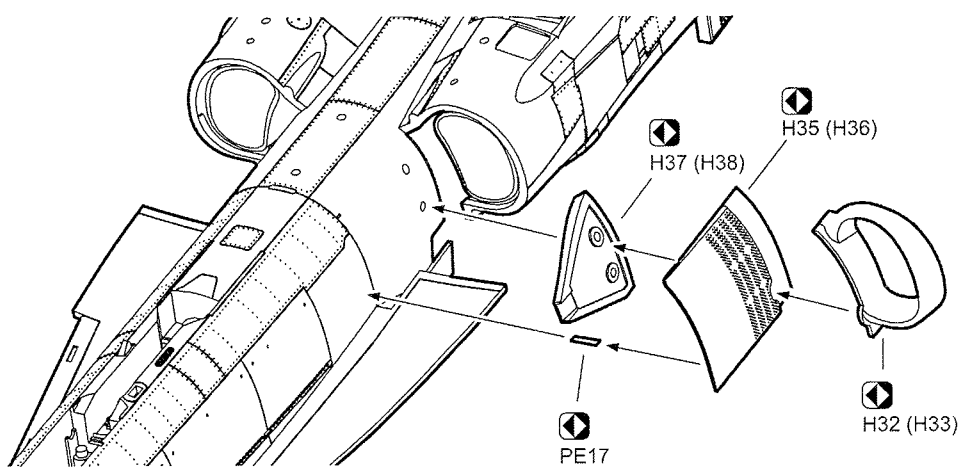

11

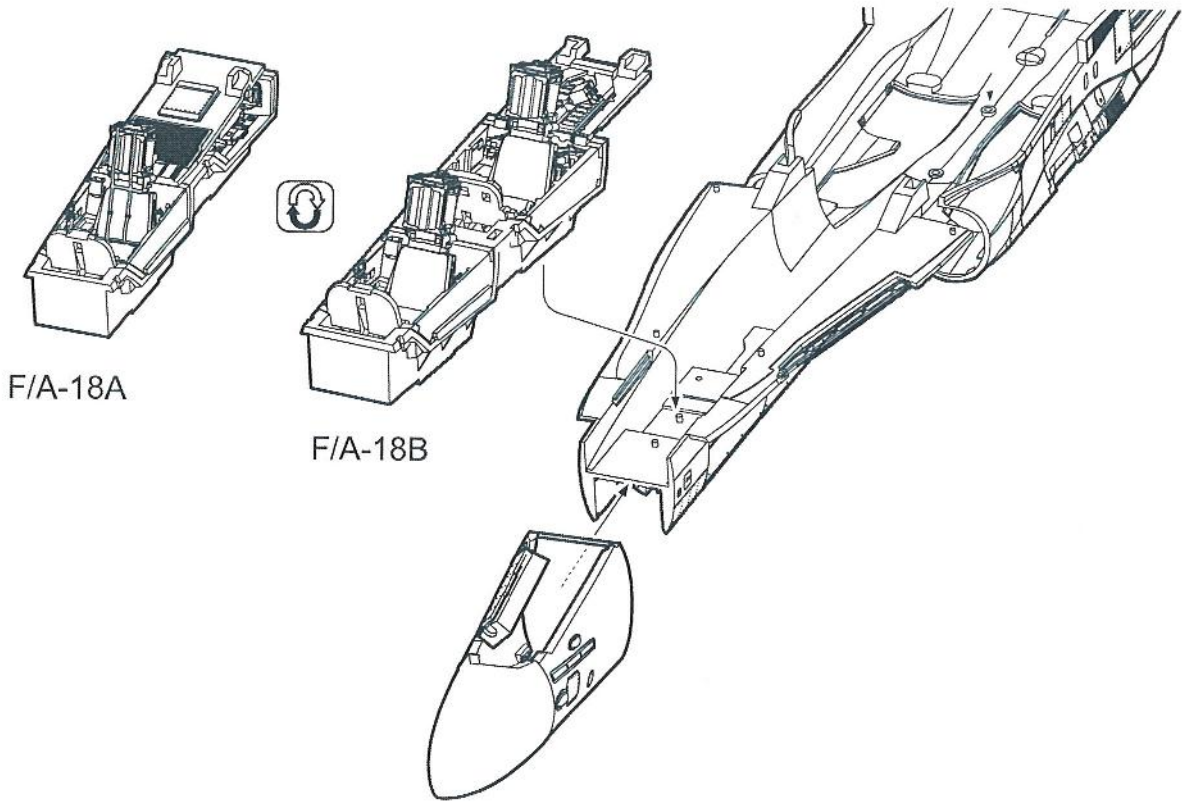

12

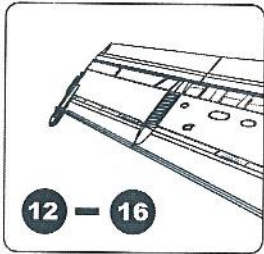

Wings extended

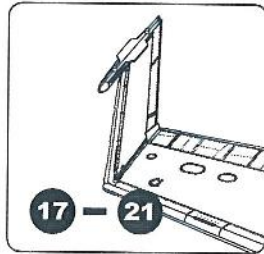

Fold Wings

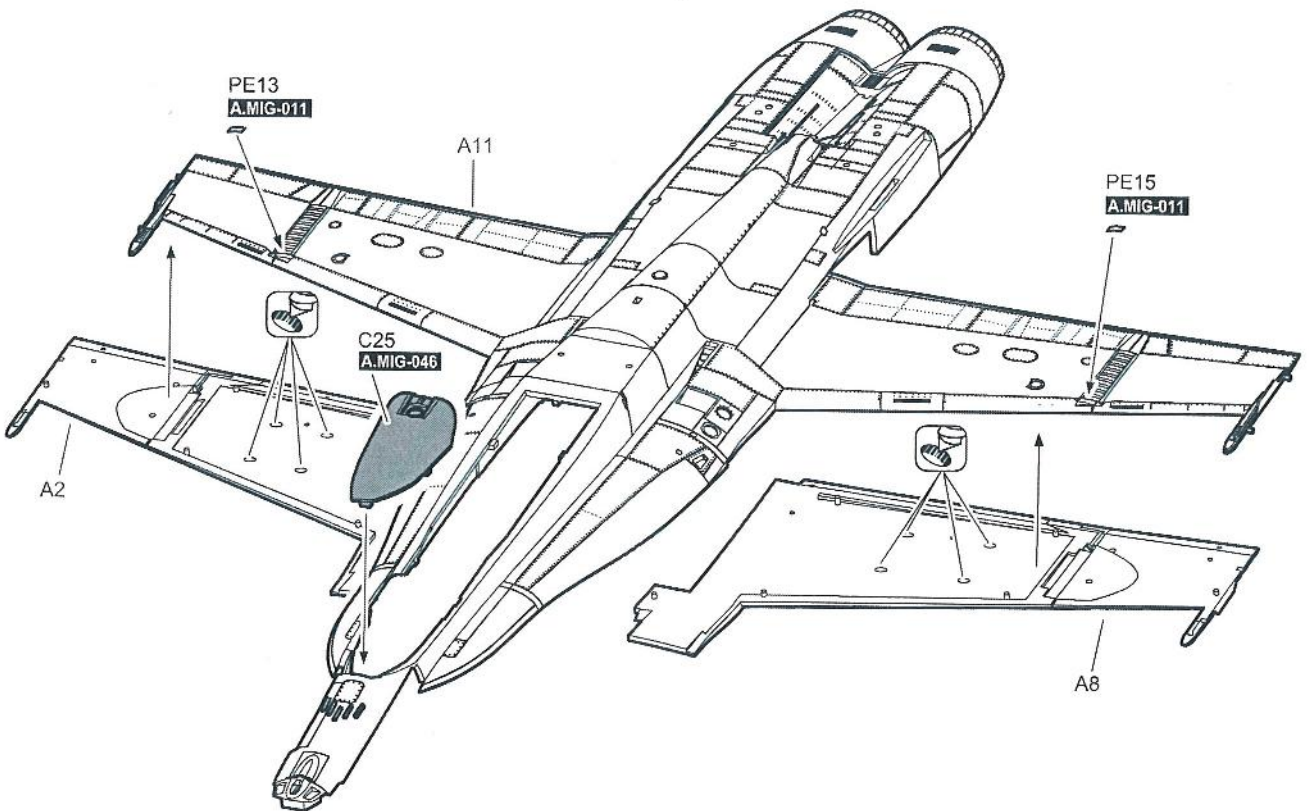

13

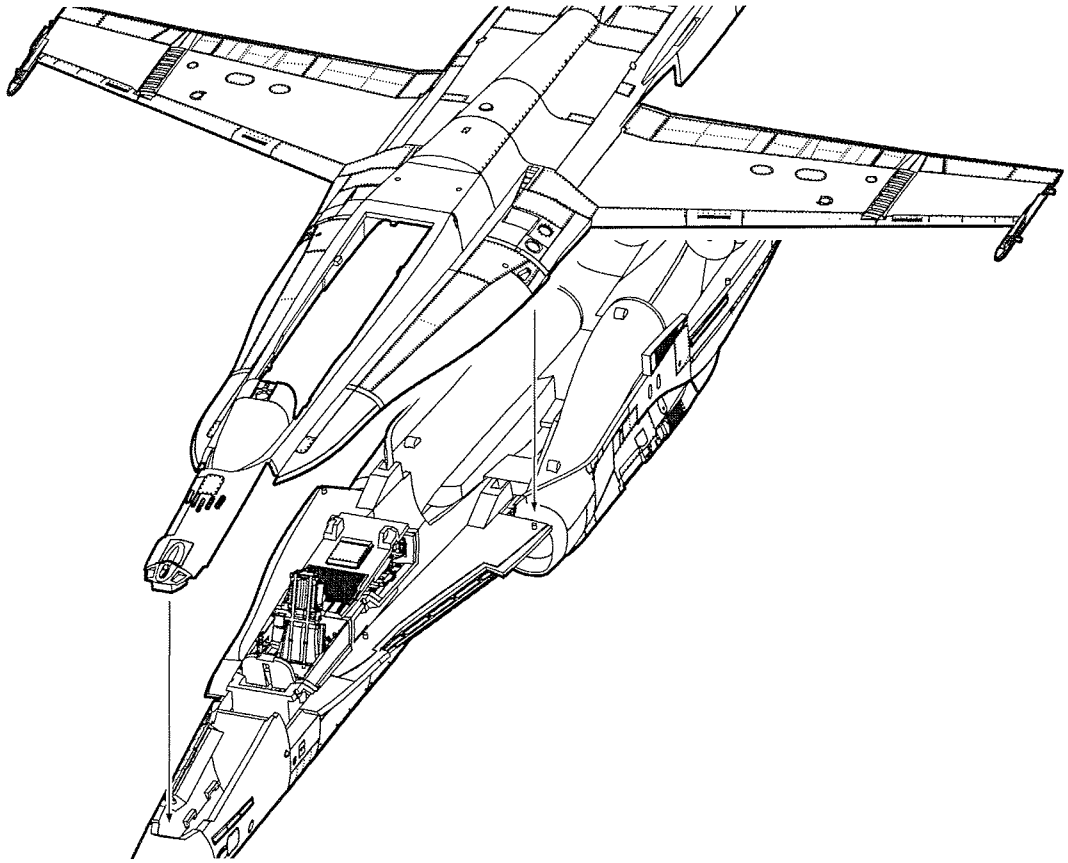

14

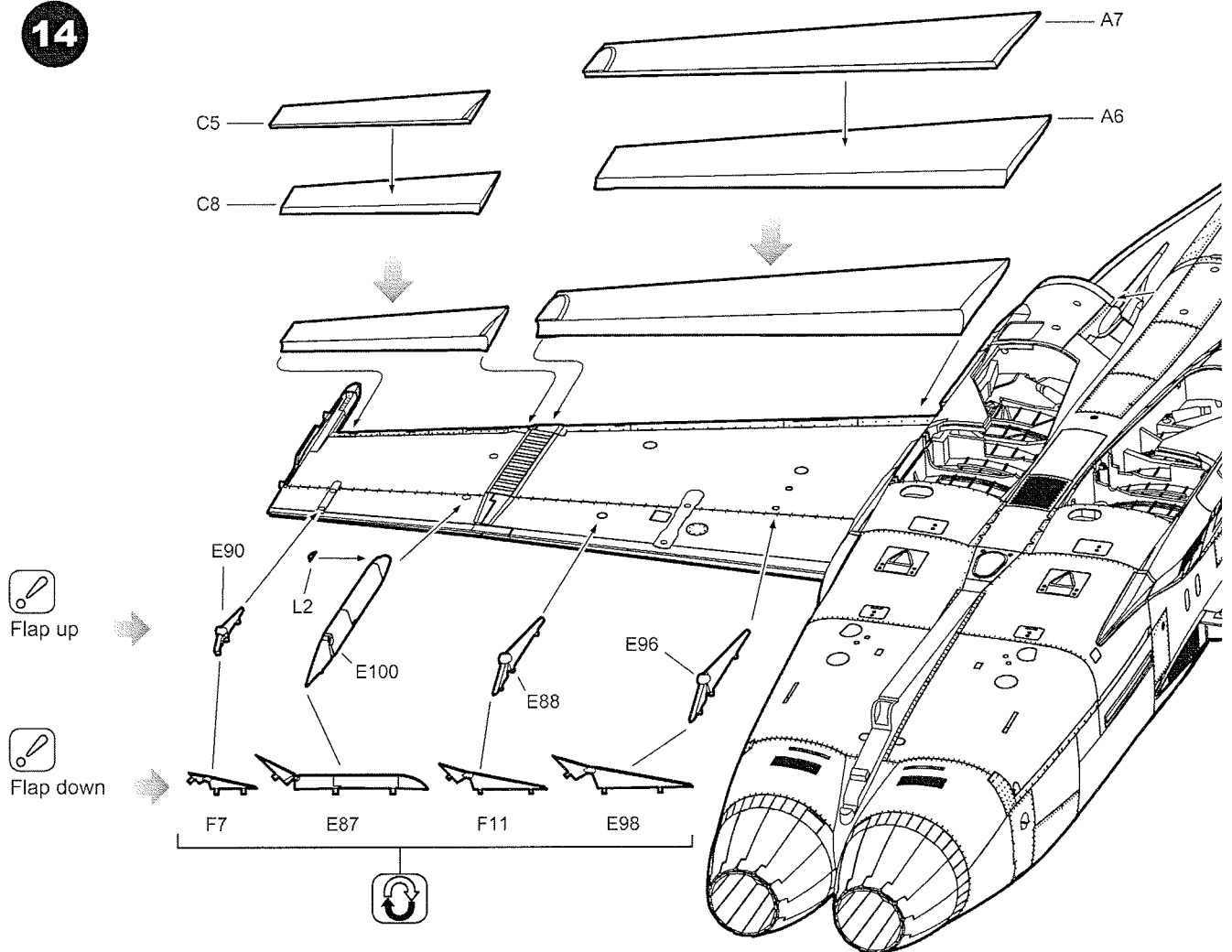

15

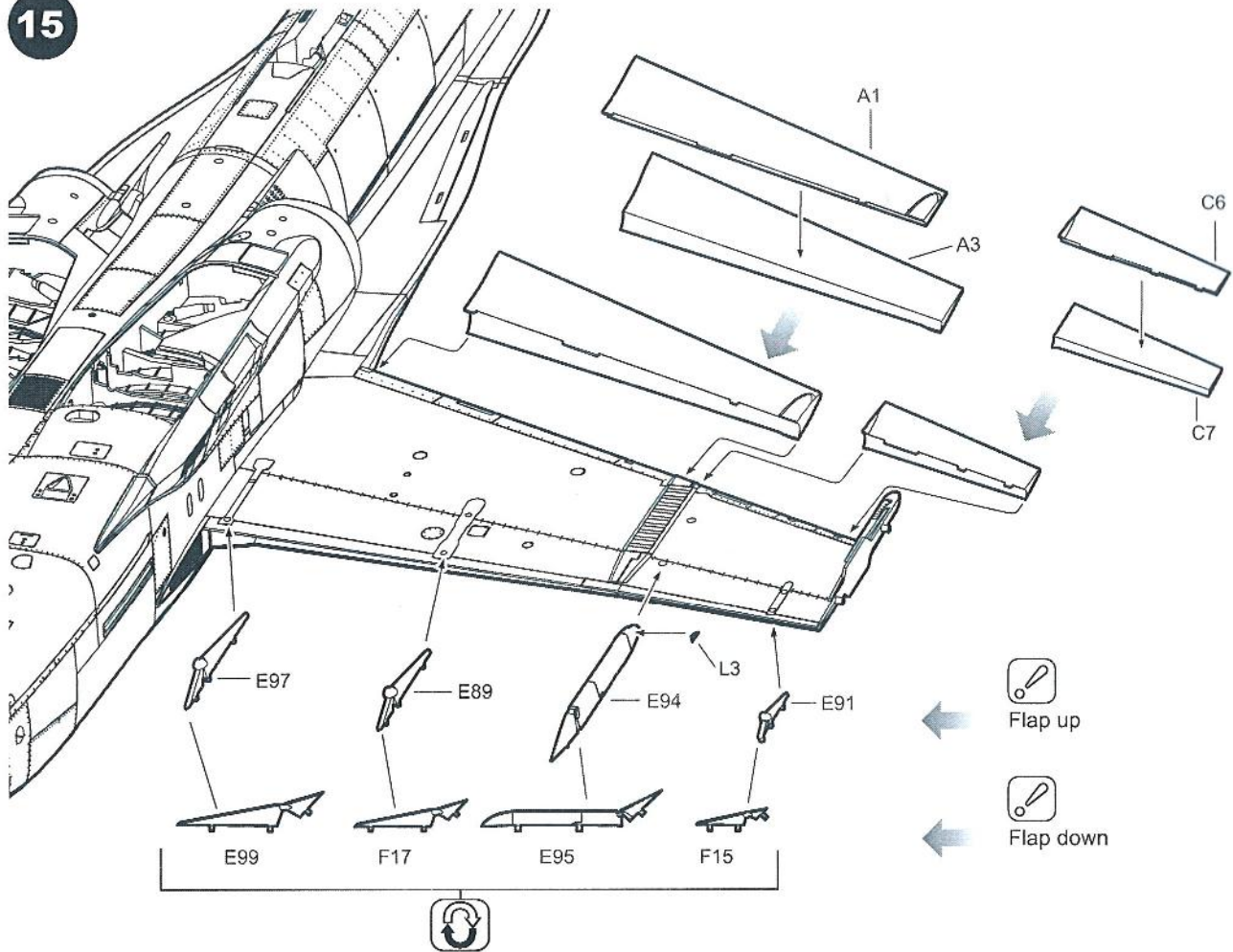

16

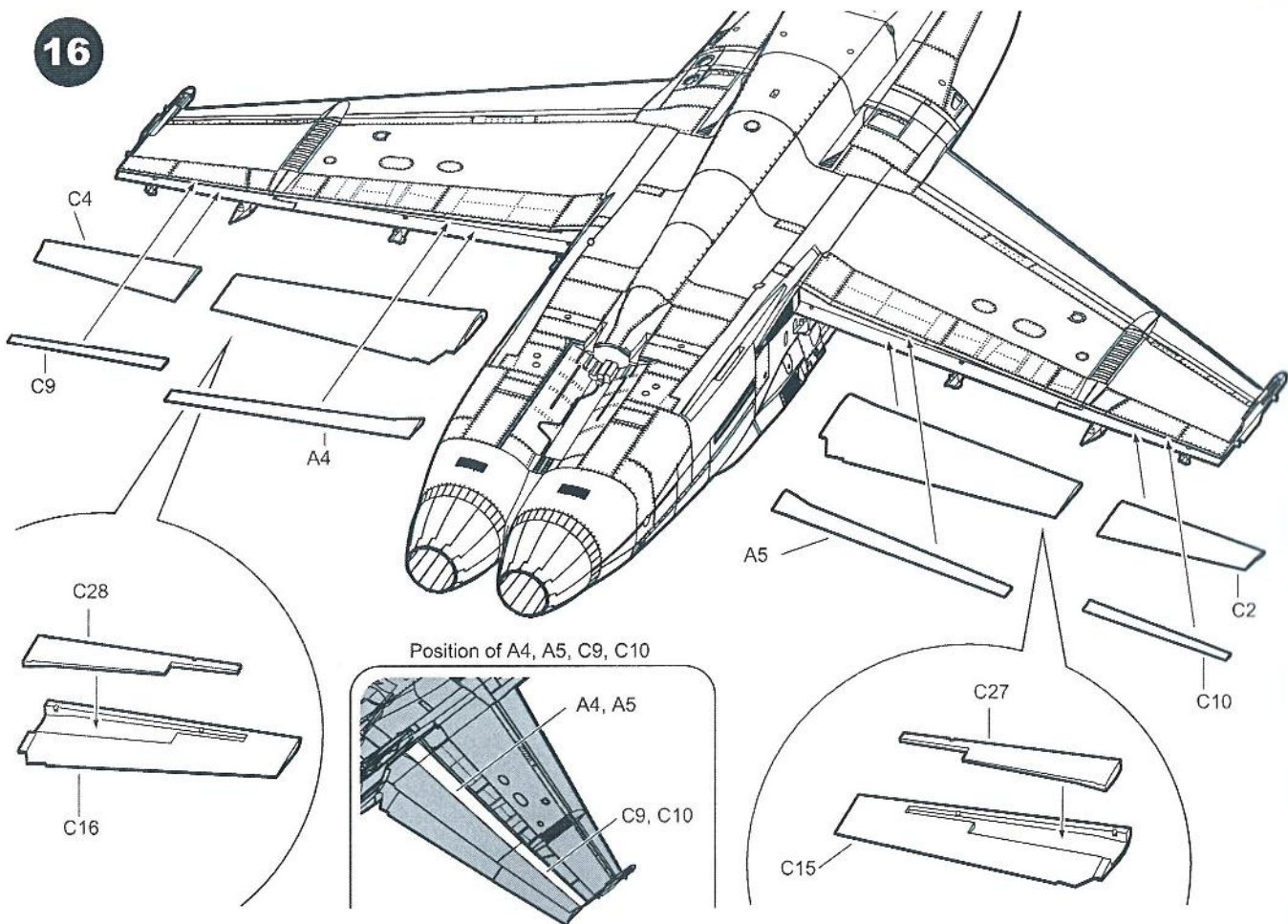

17

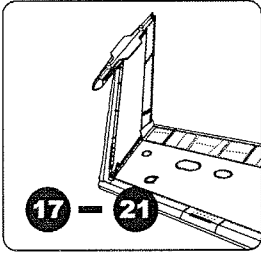

Fold Wings

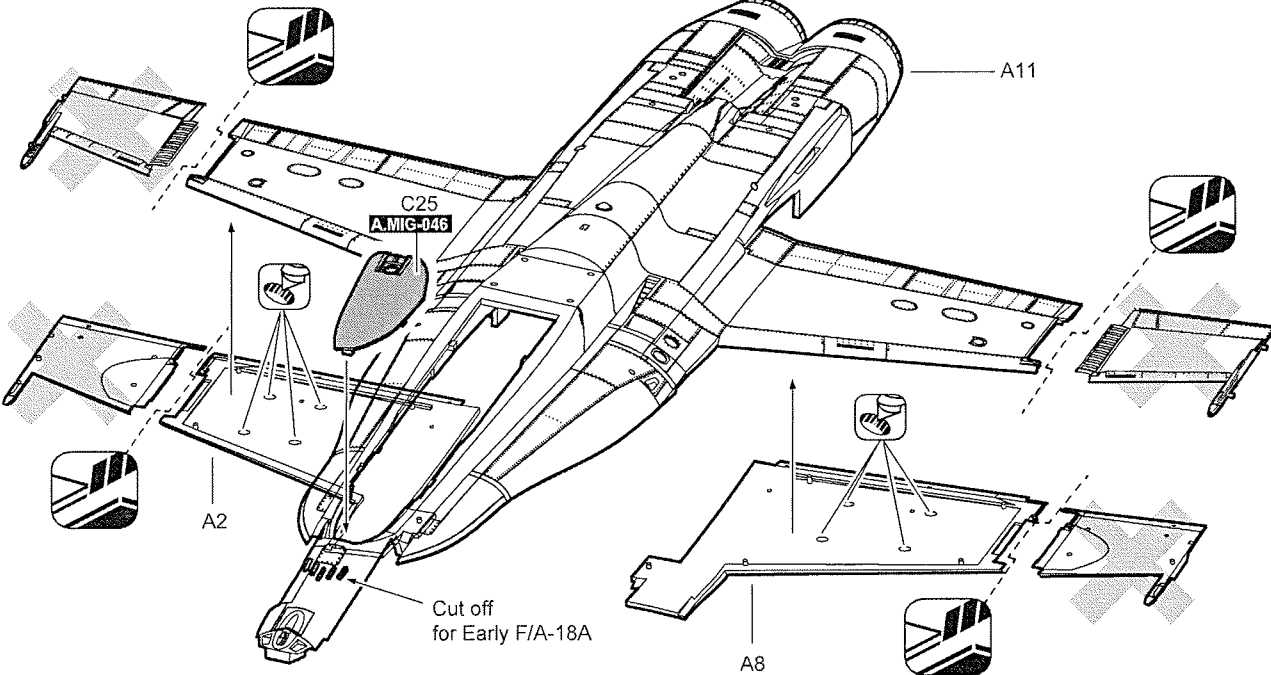

18

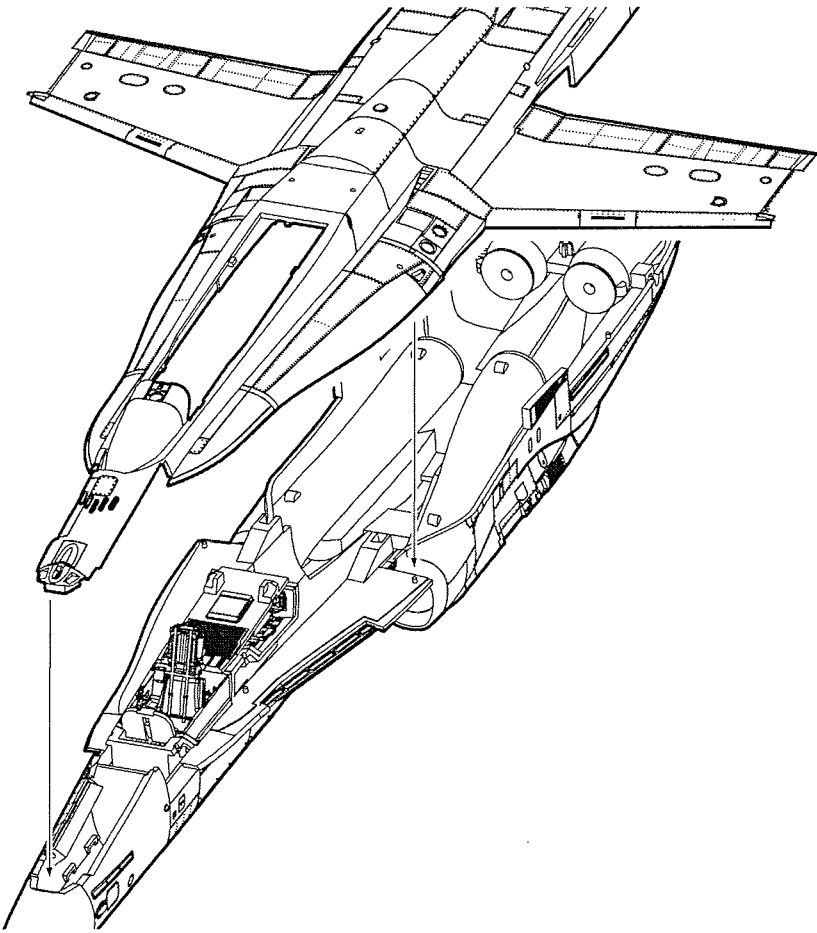

19

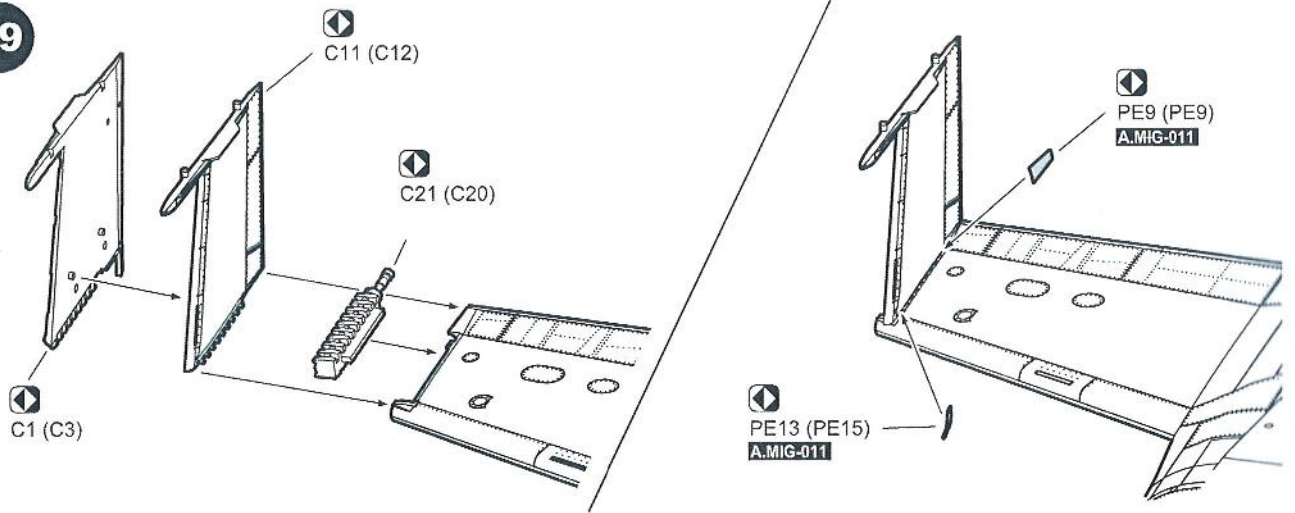

20

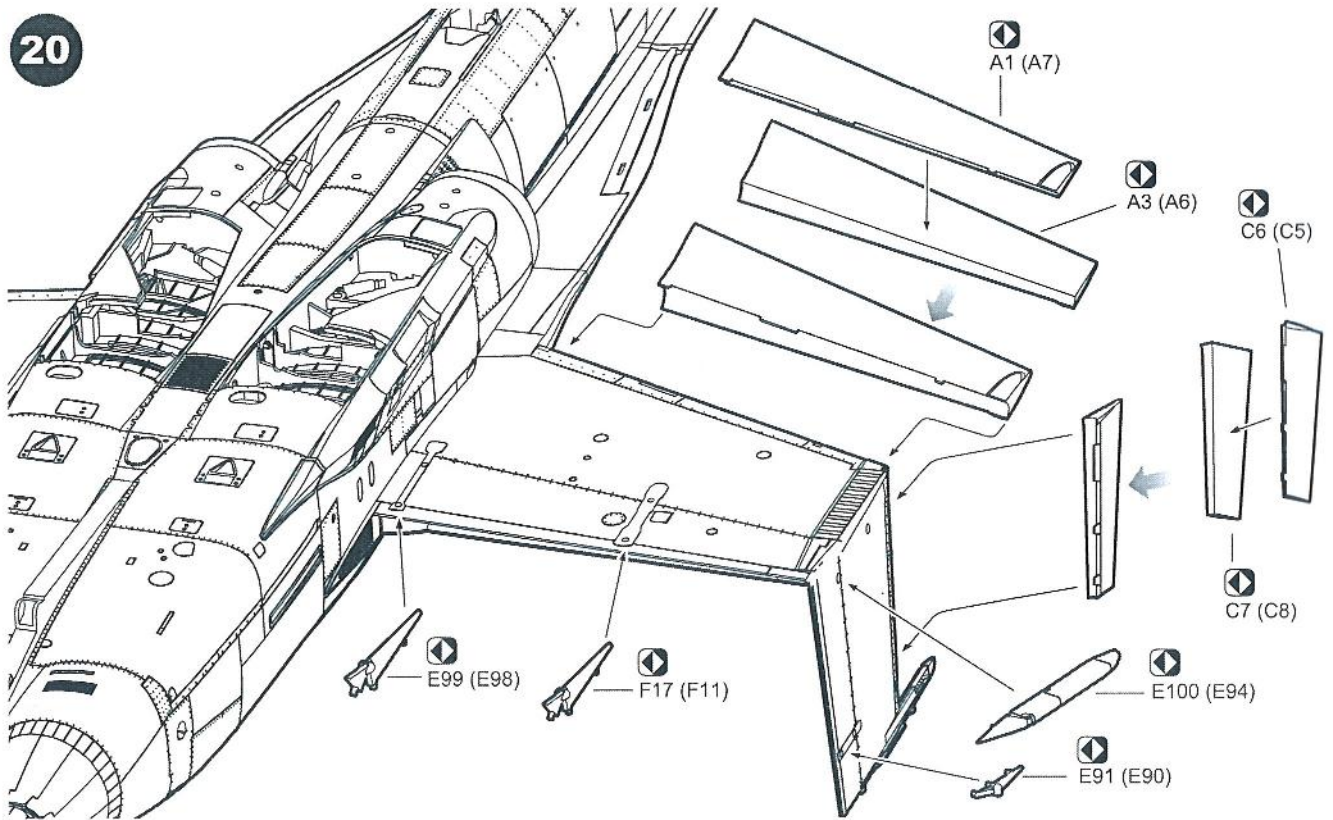

21

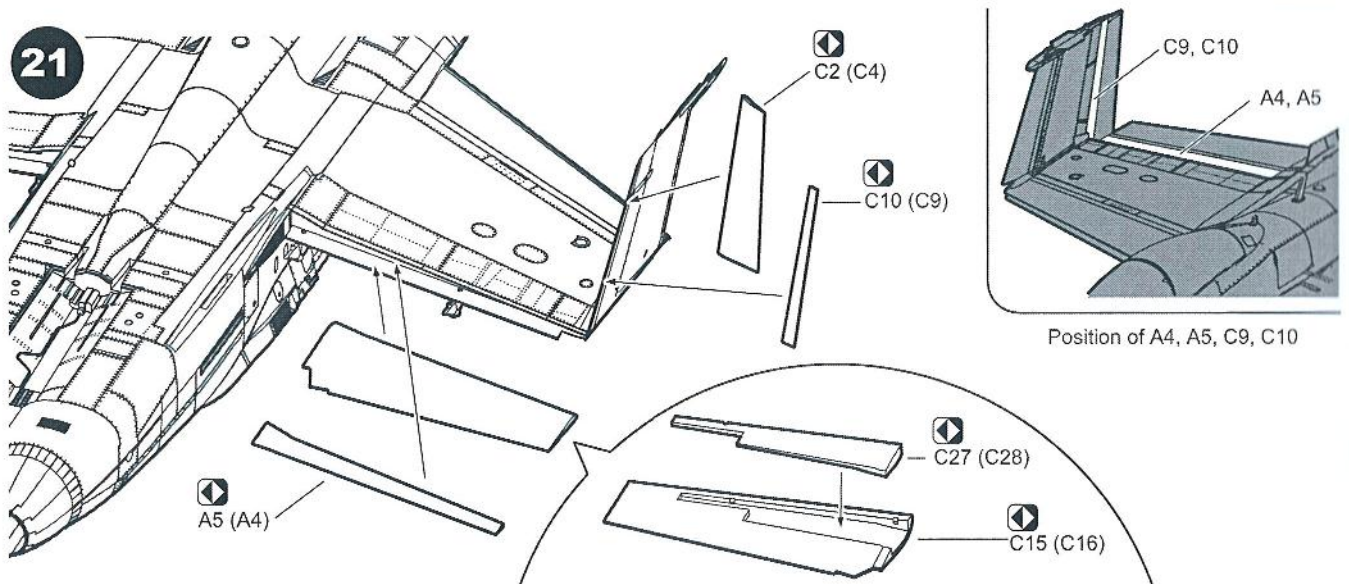

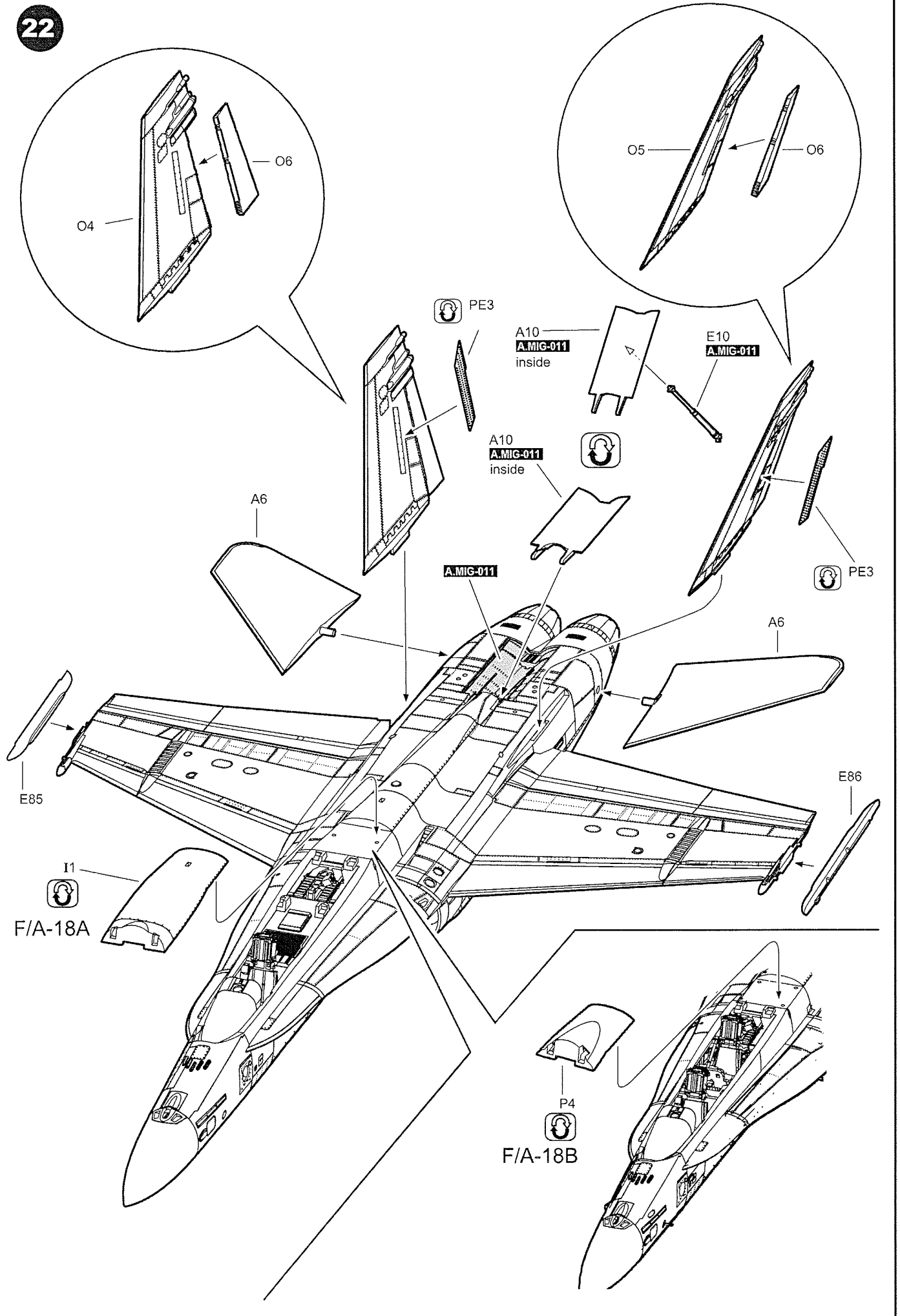

F/A-18A - Canopy 23

23

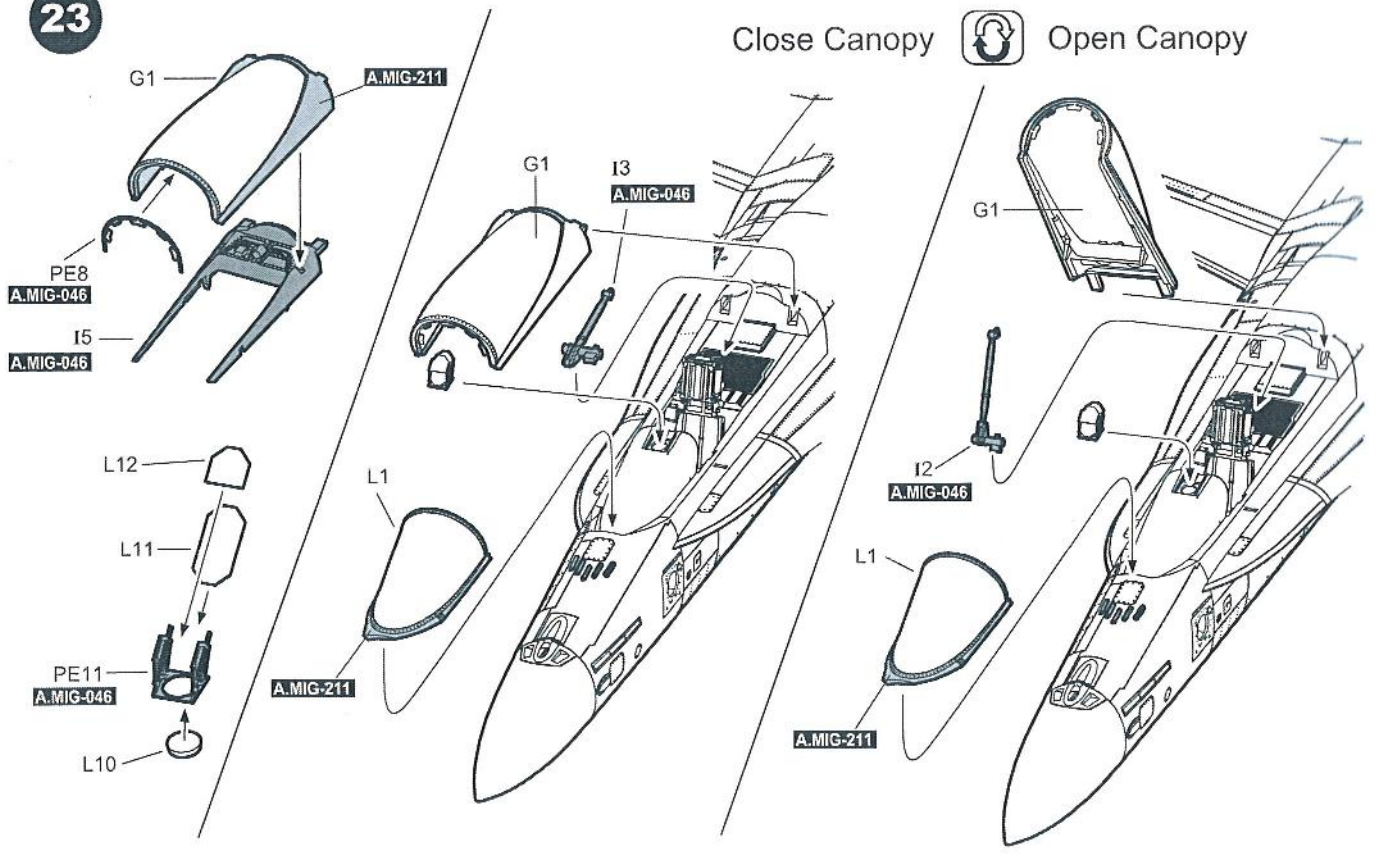

F/A-18B - Canopy 24

24

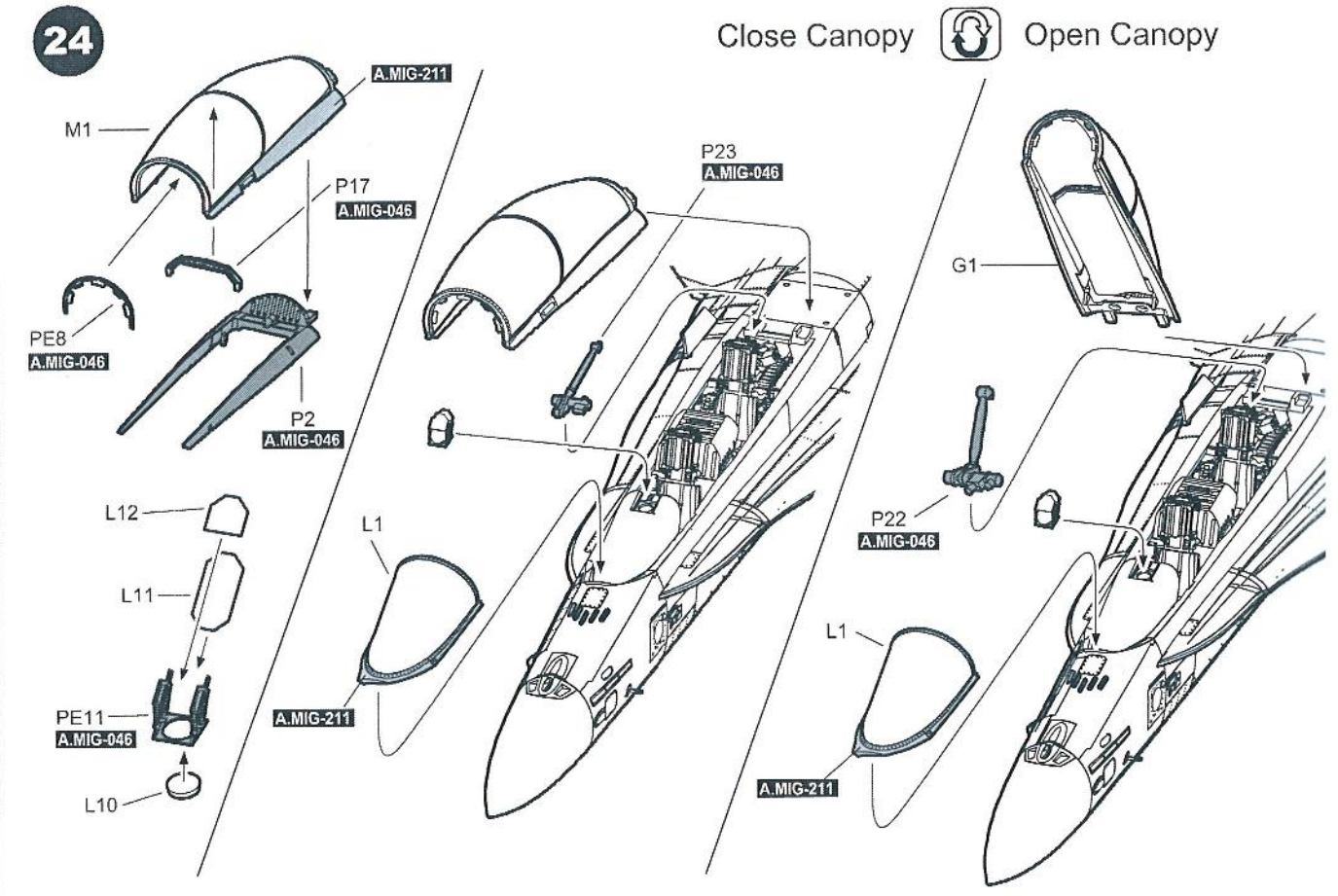

25

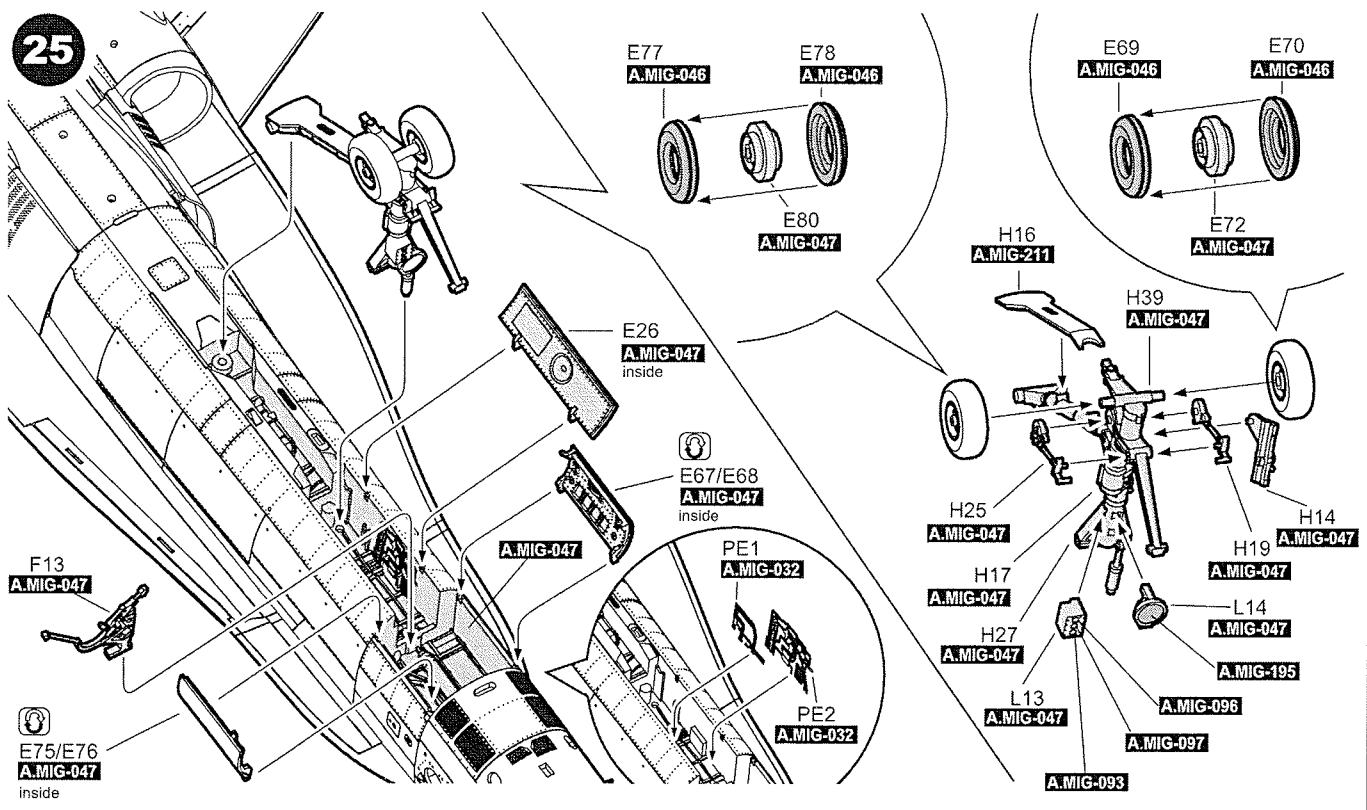

26

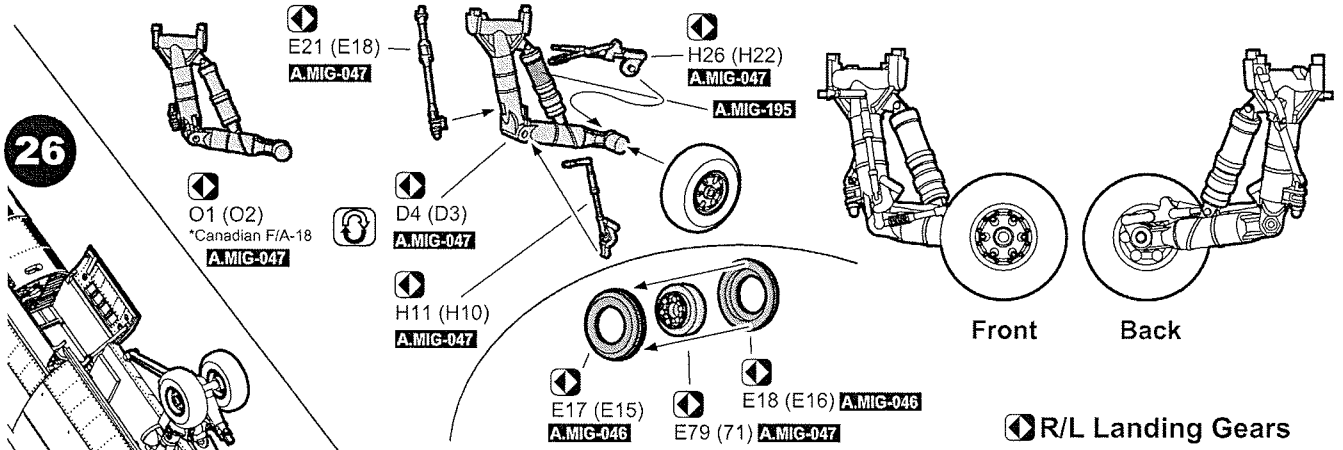

R/L Landing Gears

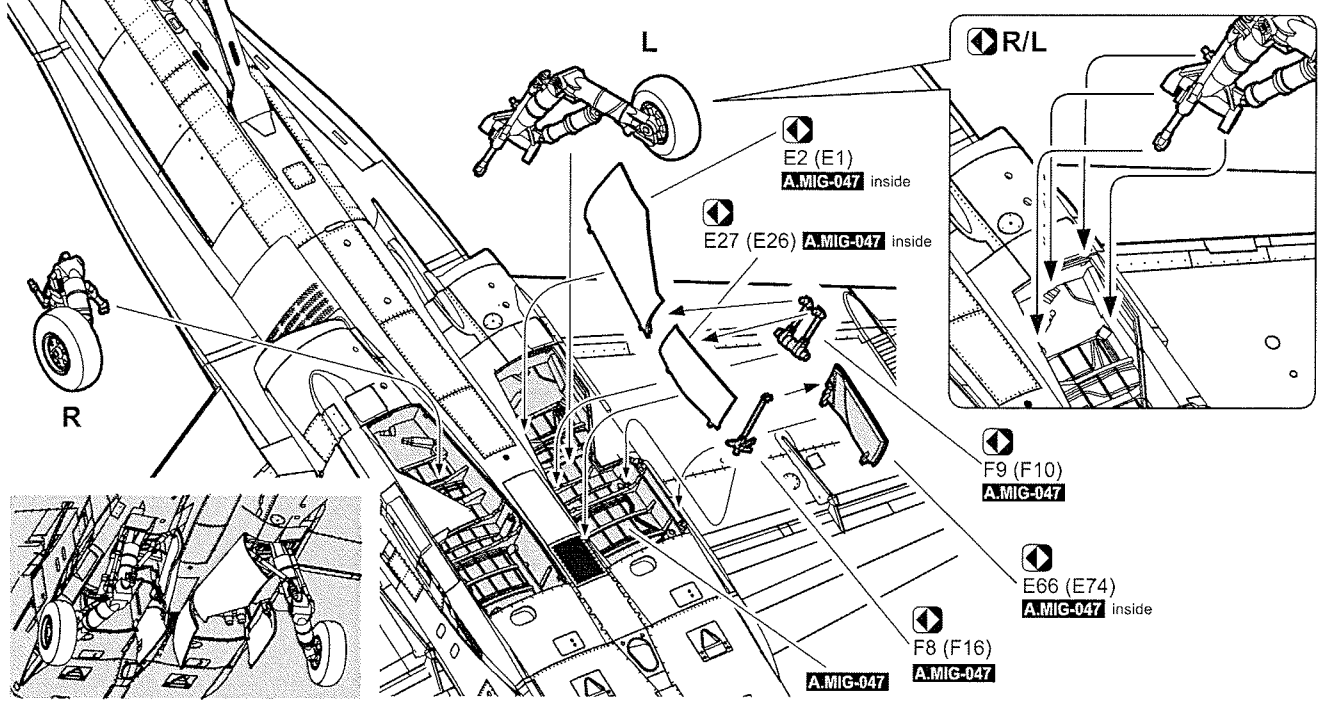

27

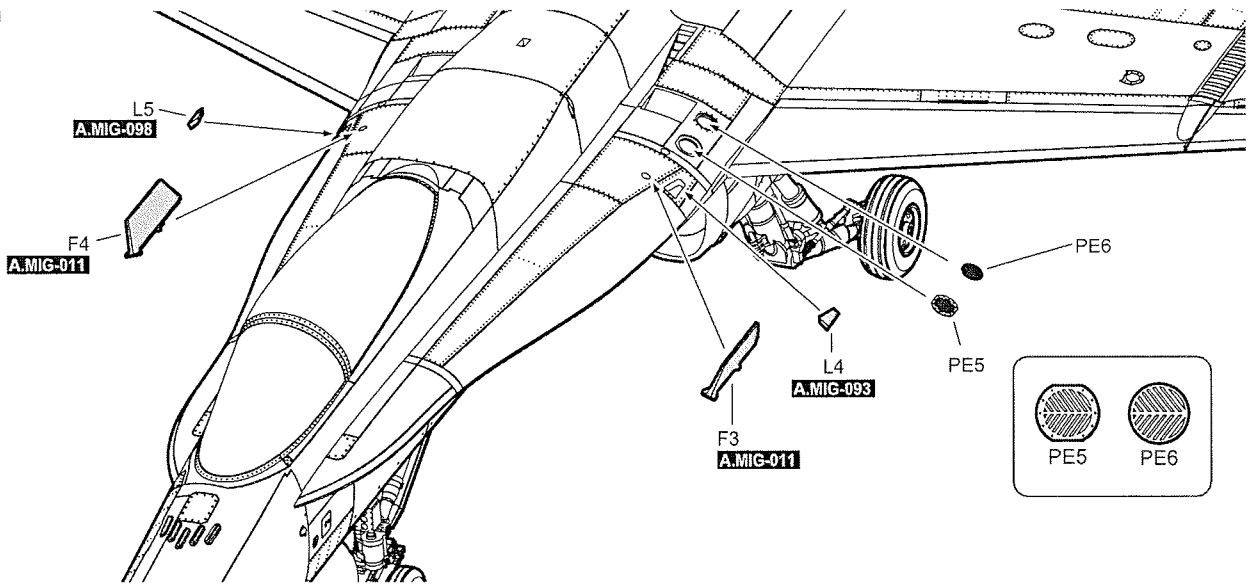

28

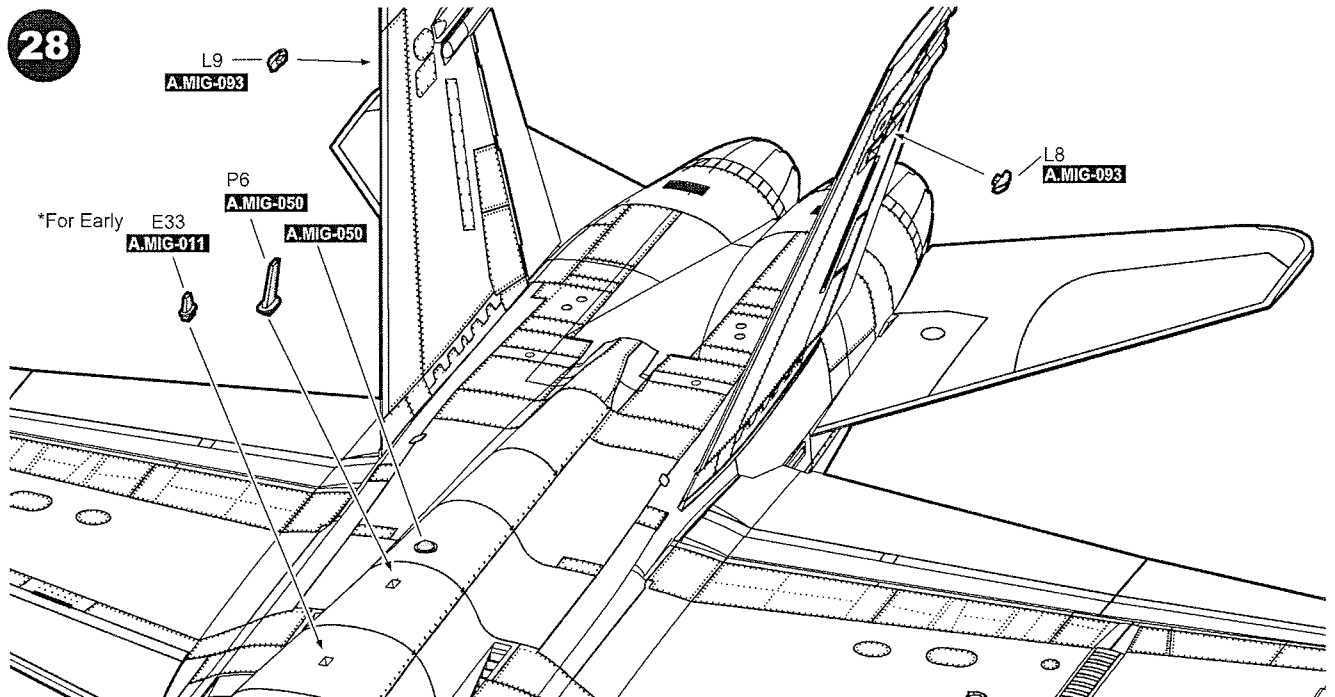

29

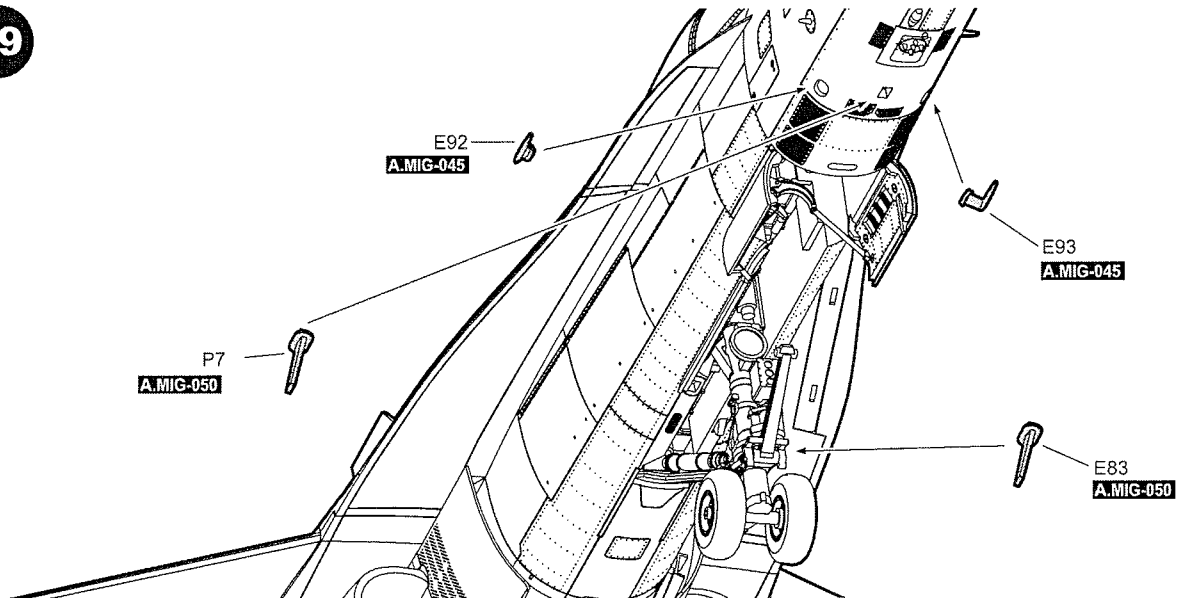

30

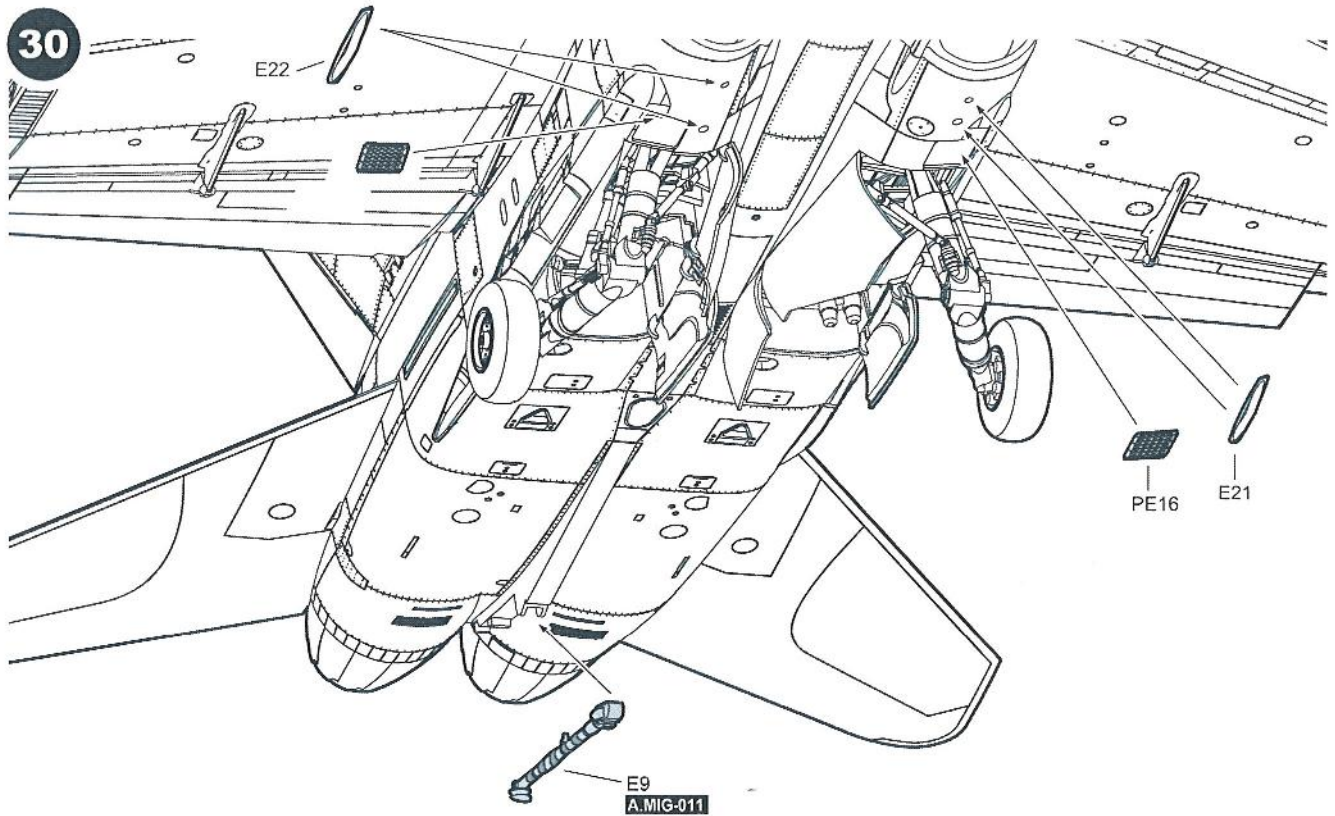

31

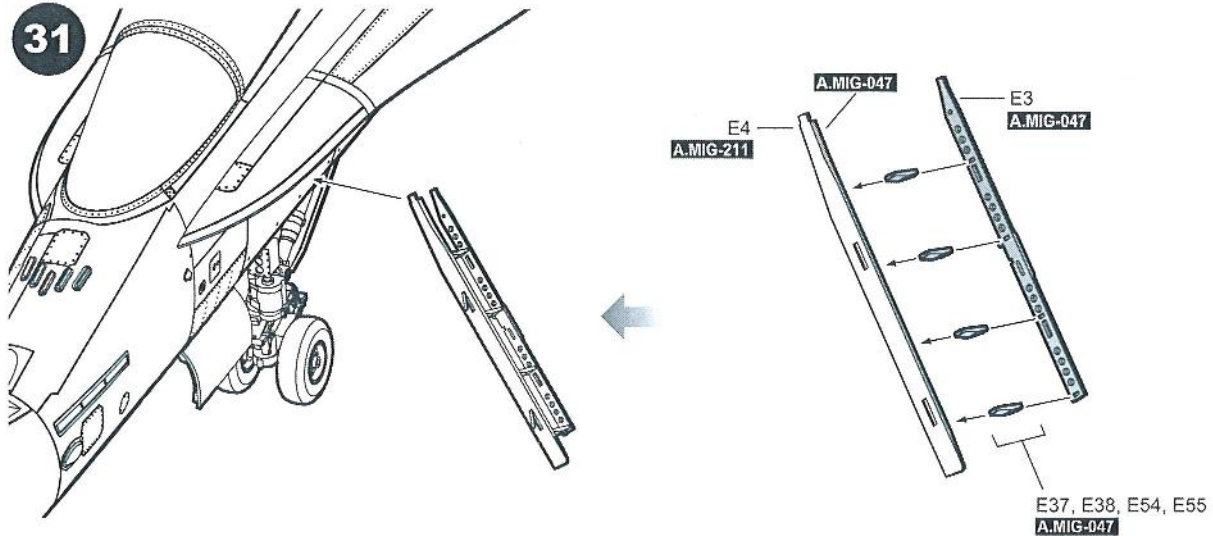

32

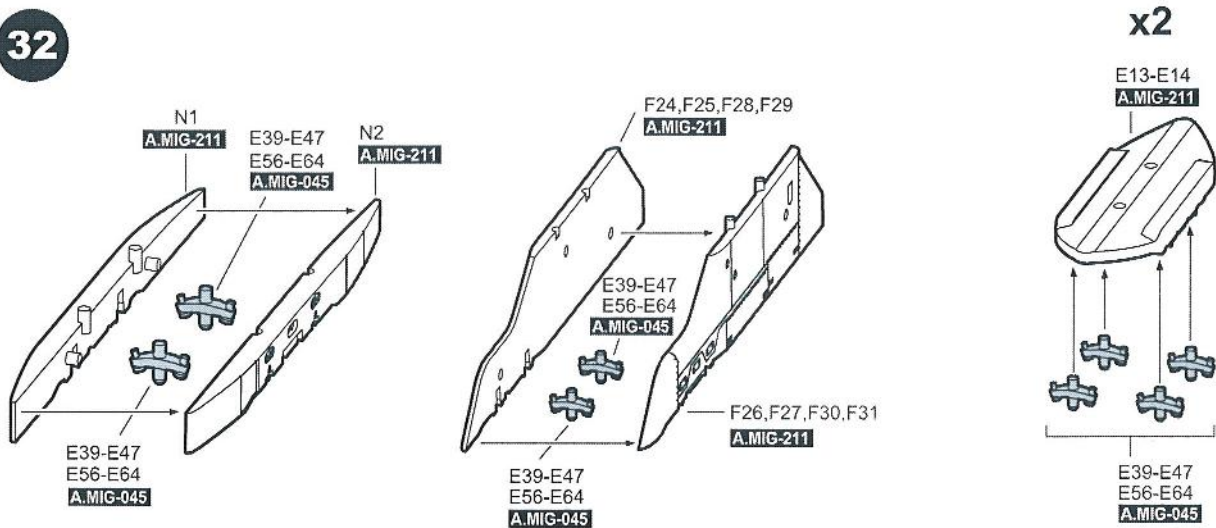

AIM-120B

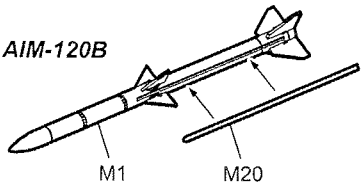

AIM-9M

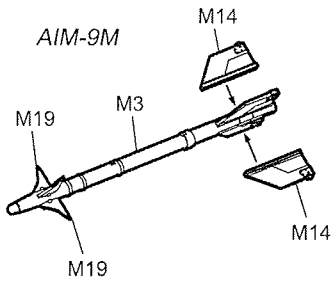

AIM-9X

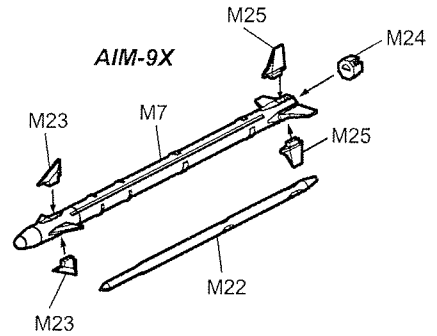

GBU-38

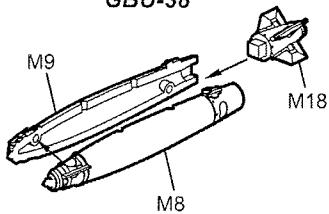

GBU-87

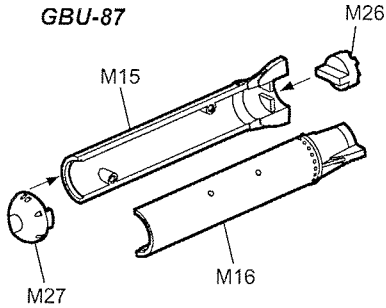

GBU-12

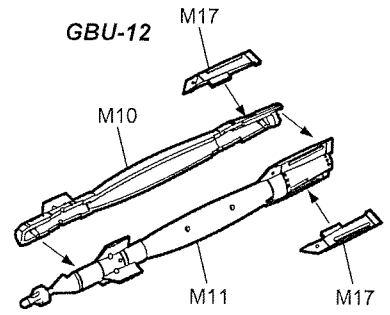

AIM-120C

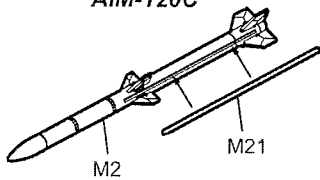

AAQ-28

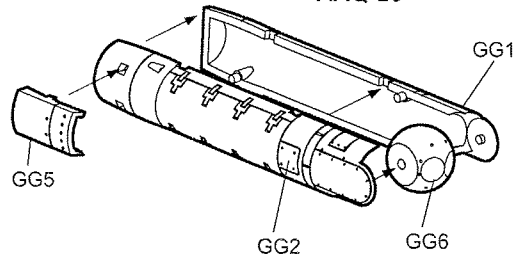

SNIPER XR

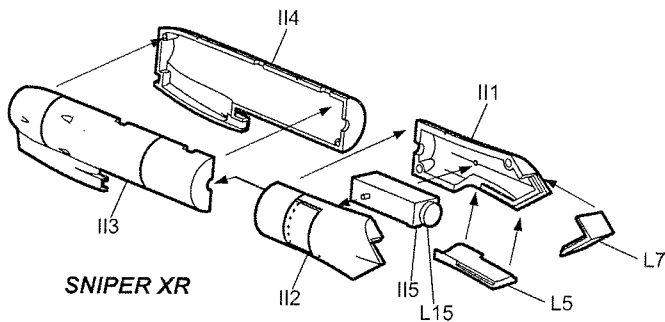

E65

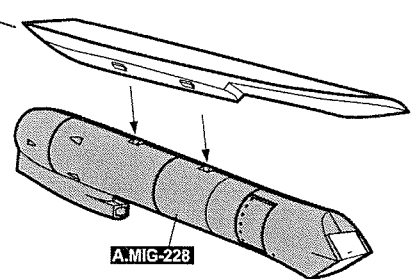

AAS-38

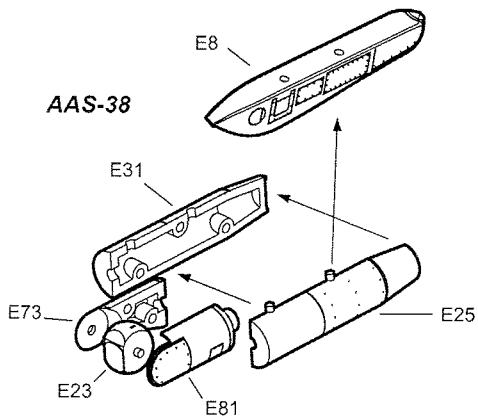

330 Gallons Tank x3

F18, F20, F22
A.MIG-211

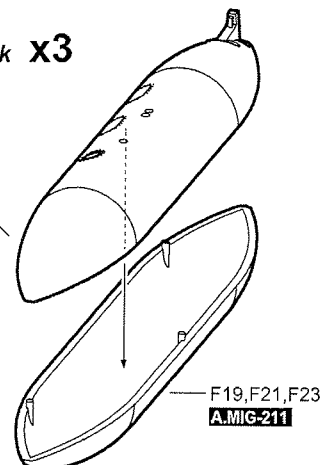

Painting & Decal Placement - External Stores

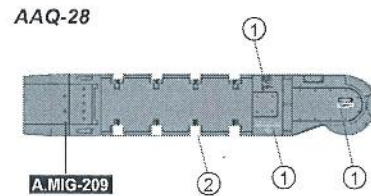
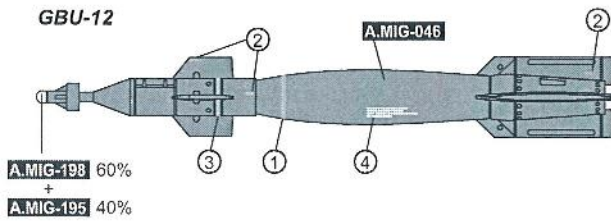
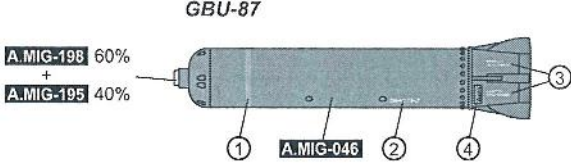
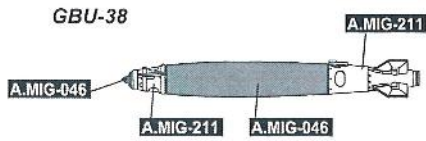
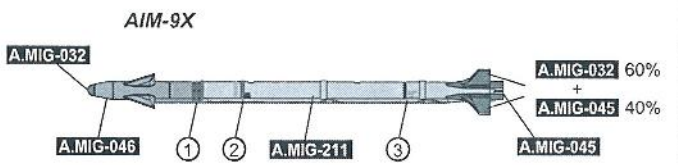
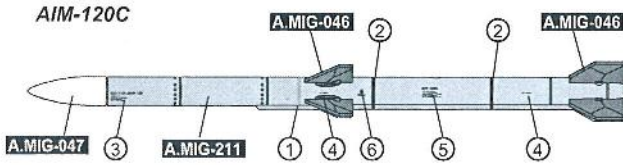
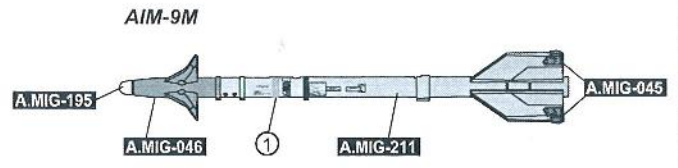
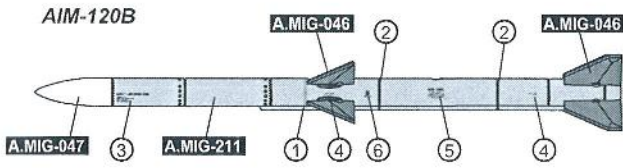

EXTERNAL STORES

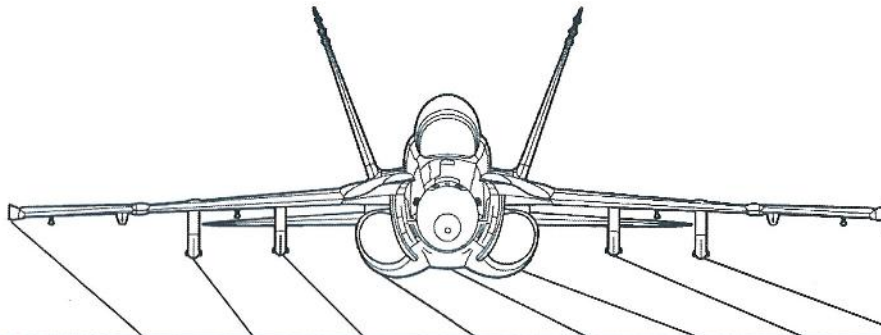

Weapons	Sta. No.	<9>	<8>	<7>	<6>	<5>	<4>	<3>	<2>	<1>
AIM-9MX		●								●
AIM-120			●		●		●		●	
GBU-12			●	●				●	●	
GBU-38			●						●	
AAQ-32							●			
AAQ-28					●	●				
CBU-10			●	●	●			●	●	●
AAQ-38							●			
FUEL TANK 330 Gallons				●		●		●		



PAINT INDEX

COLOR	AMMO MIG	VALLEJO MODEL COLOR	GSI CREOS MR. COLOR	TAMIYA ENAMEL/ACRYLIC	HUMBROL ENAMEL
B RESEDAGRÜN	A.MIG-004	823	-	X05	2
DUNKELGELB AUS '44 DG I	A.MIG-011	830	-	XF62	66
PROTECTIVE GREEN	A.MIG-023	891	-	-	117
SAND BROWN	A.MIG-026	874	-	-	-
DESERT SAND	A.MIG-029	916	-	-	250
SAND YELLOW	A.MIG-030	887	304	XF72	155
SATIN BLACK	A.MIG-032	861	2	-	21
OLD WOOD	A.MIG-036	879	81	-	-
GUN METAL	A.MIG-045	863	76	XF56	53
MATT BLACK	A.MIG-046	950	12	XF1	33
SATIN WHITE	A.MIG-047	842	1	-	22
YELLOW	A.MIG-048	953	413	XF3	15
RED	A.MIG-049	957	-	XF07	153
MATT WHITE	A.MIG-050	951	11	XF2	34
BLUE	A.MIG-086	963	-	-	52
CRYSTAL RED	A.MIG-093	934	-	-	220
CRYSTAL PERISCOPE GREEN	A.MIG-096	936	-	-	-
CRYSTAL ORANGE	A.MIG-097	935	-	-	-
CRYSTAL LIGHT BLUE	A.MIG-098	938	-	-	-
SILVER	A.MIG-195	997	8	XF16	11
GOLD	A.MIG-198	996	9	-	-
GHOST GRAY	A.MIG-208	991	317	XF54	27
LIGHT GRAY	A.MIG-209	990	308	-	-
GRAY BLUE	A.MIG-210	901	-	-	-
MEDIUM GRAY	A.MIG-211	989	-	XF19	127
INTERMEDIATE BLUE	A.MIG-228	867	36	XF54	79
OLIVE DRAB LIGHT BASE	A.MIG-927	893	309	XF27	91
RUSSIAN SHINE	A.MIG-935	838	-	-	-

IP DECAL

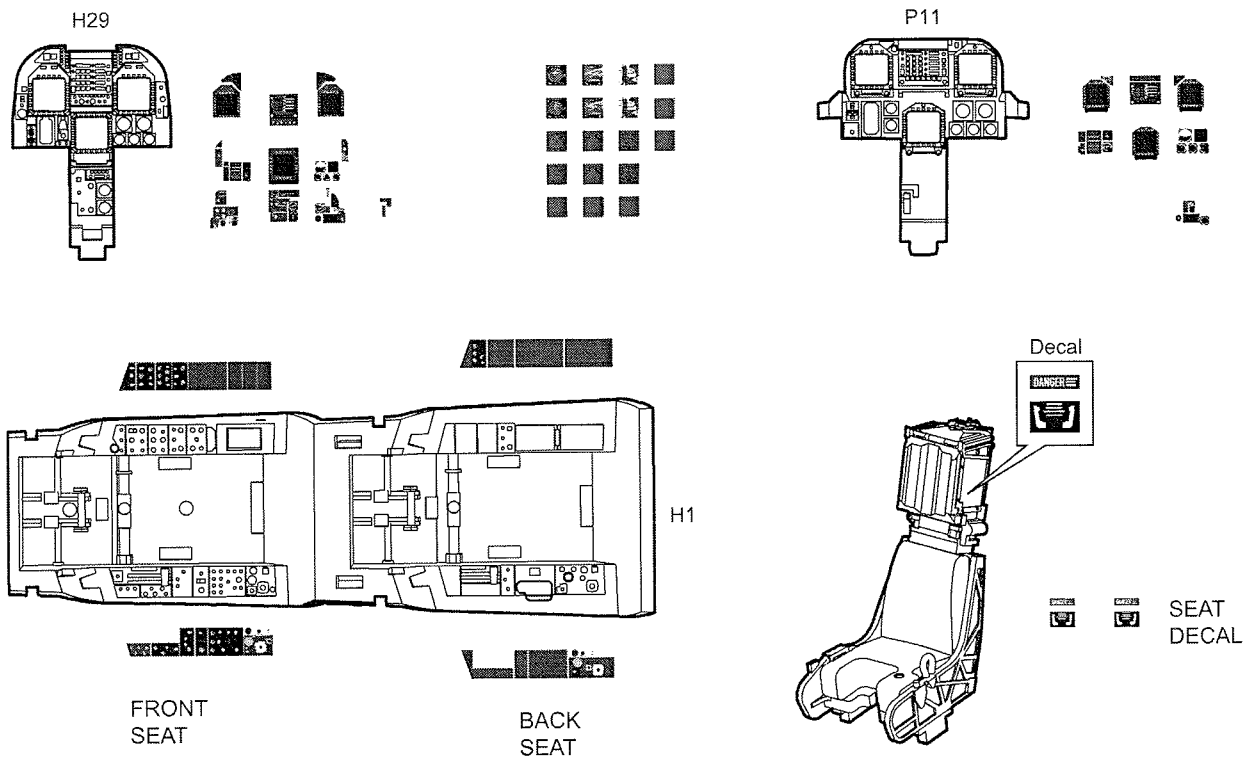

Top marking of Canadian Air Force

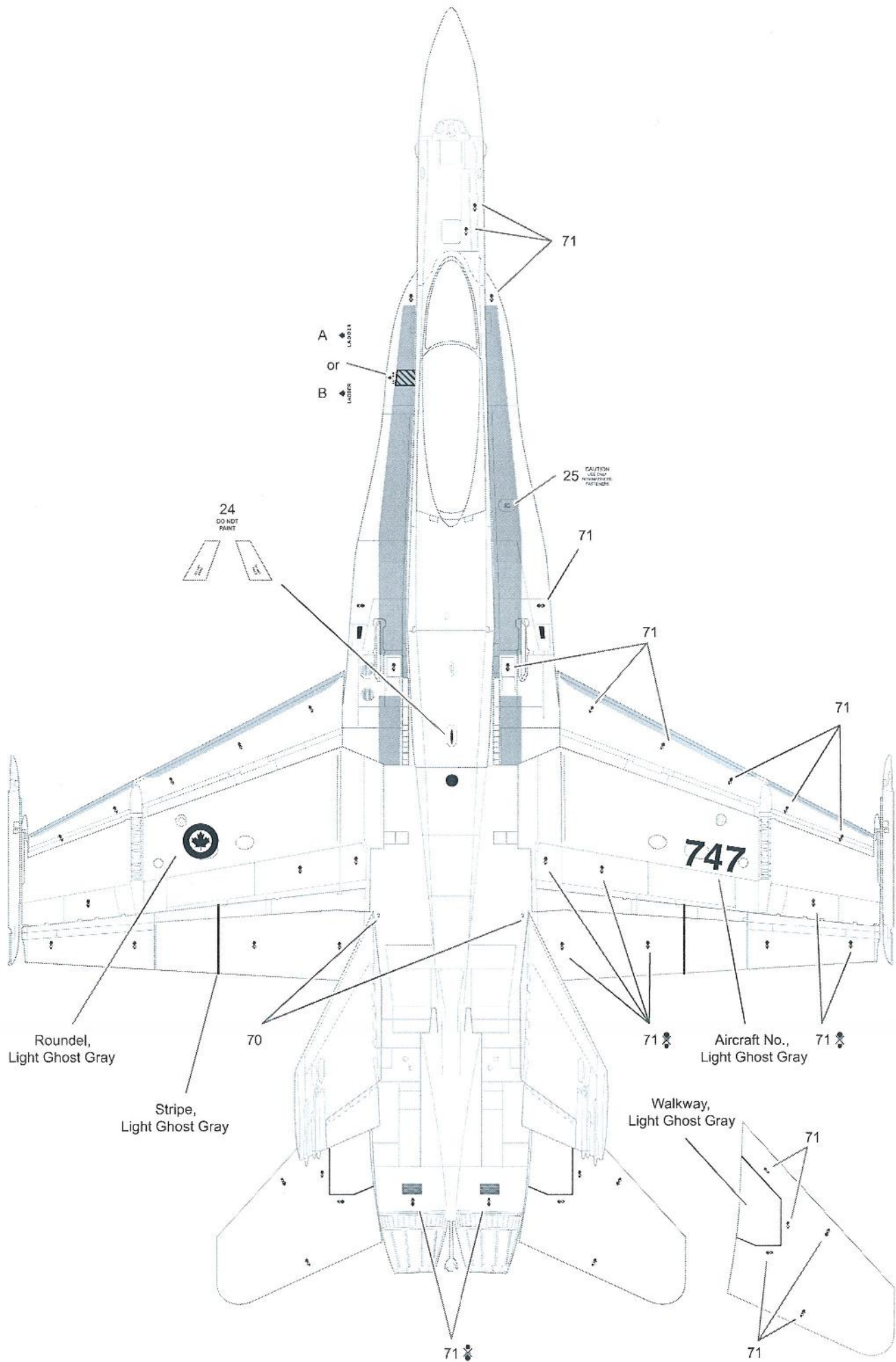

Top marking of Royal Australian Air Force / Spanish Air Force

Use Light ghost gray markings for RAAF, Black for SPAF.

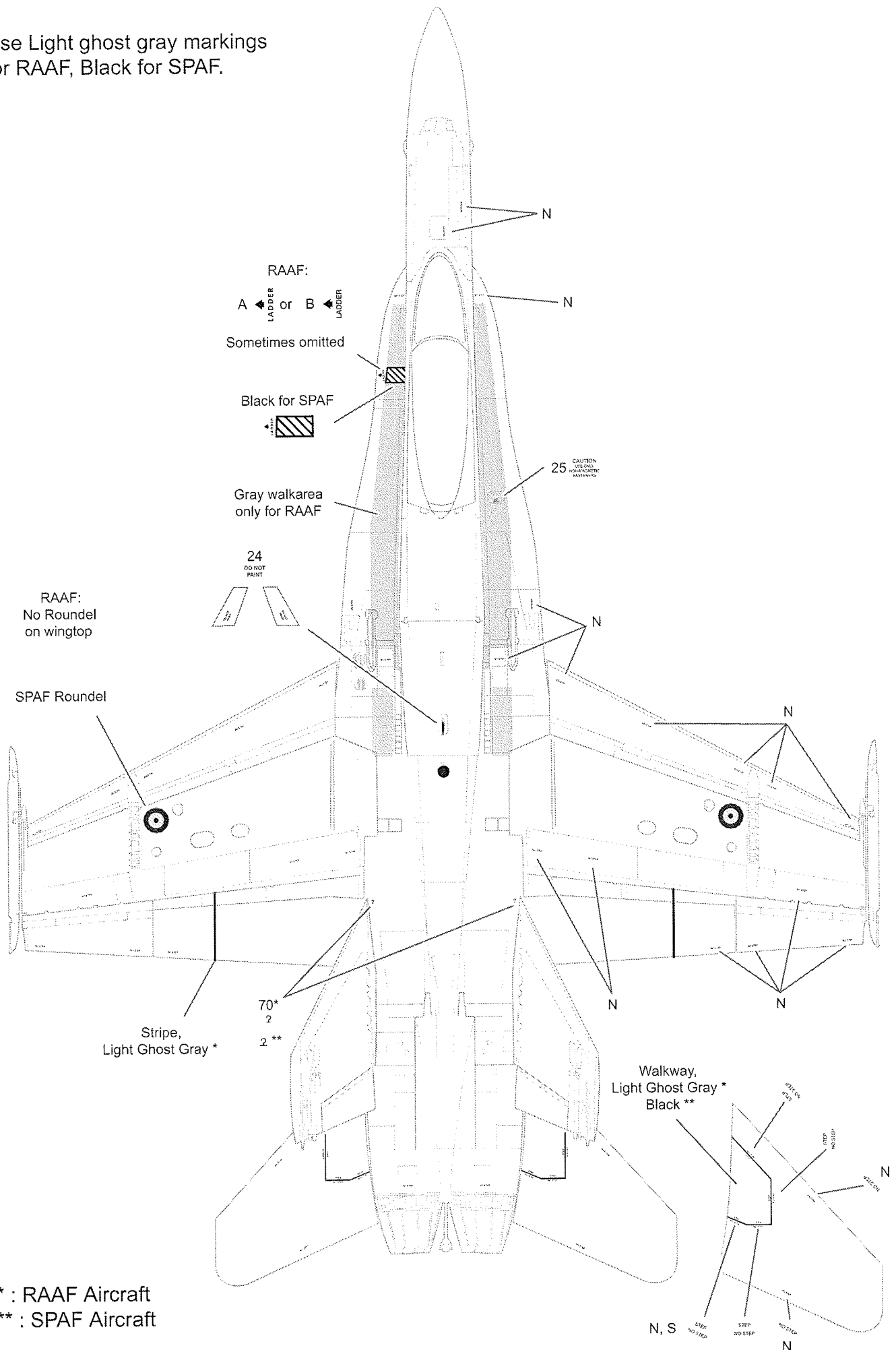

* : RAAF Aircraft
** : SPAF Aircraft

Bottom marking of CAF / RAAF / SPAF

Use grey markings for CAF and RAAF, black for SPAF.

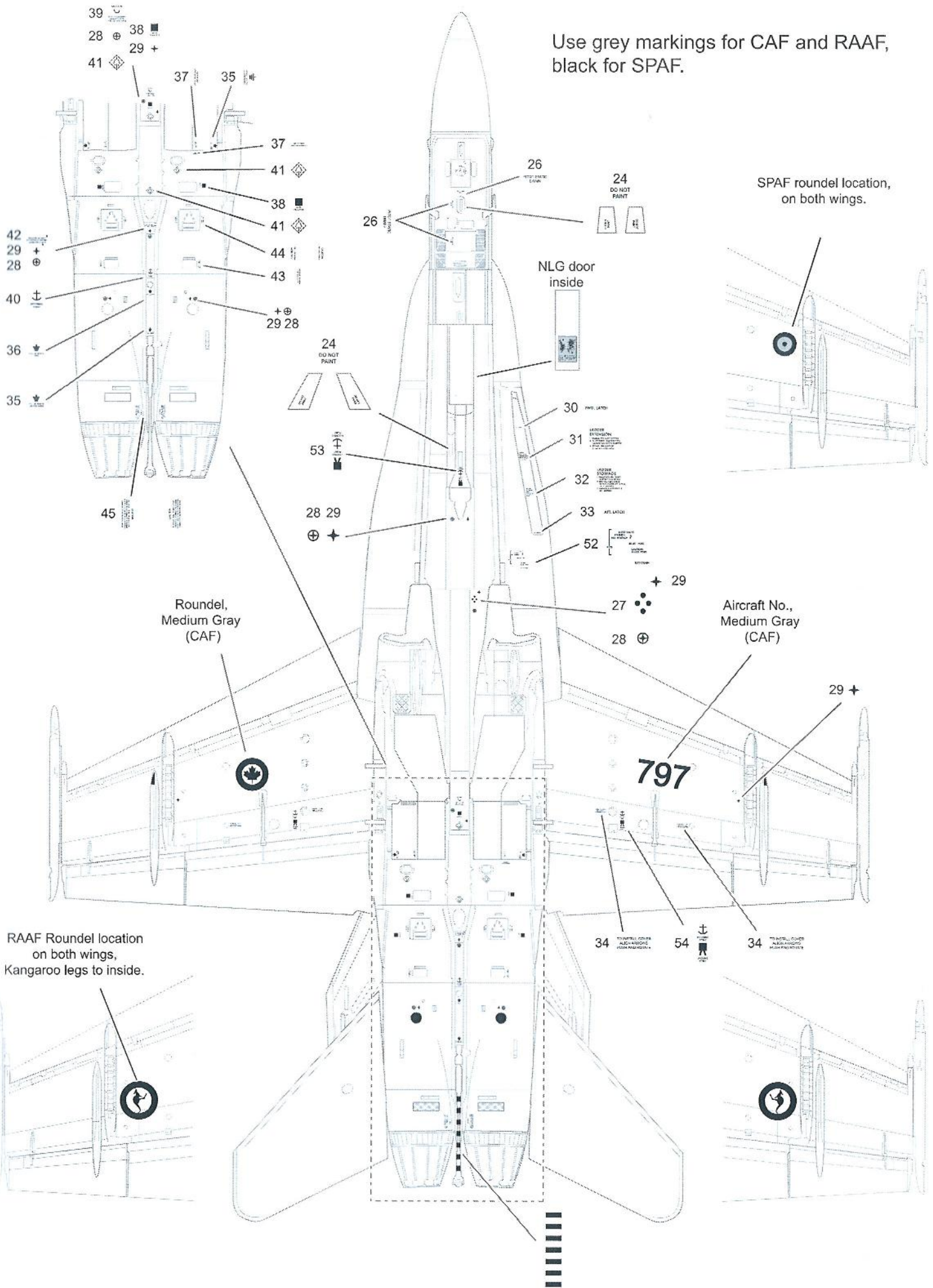

SPAF roundel location, on both wings.

Roundel, Medium Gray (CAF)

Aircraft No., Medium Gray (CAF)

797

RAAF Roundel location on both wings, Kangaroo legs to inside.

24 DO NOT PAINT

24 DO NOT PAINT

NLG door inside

30 FUEL LATCH

31 ENGINE EXTENSION

32 ENGINE HOUSING

33 AFT LATCH

52

27

28

29 +

34

54

34



1. CF-188A, 409SQ, Canadian Air Force, Jun, 2016.

Options provided: 188747, 188794
Some combination on numbers may required

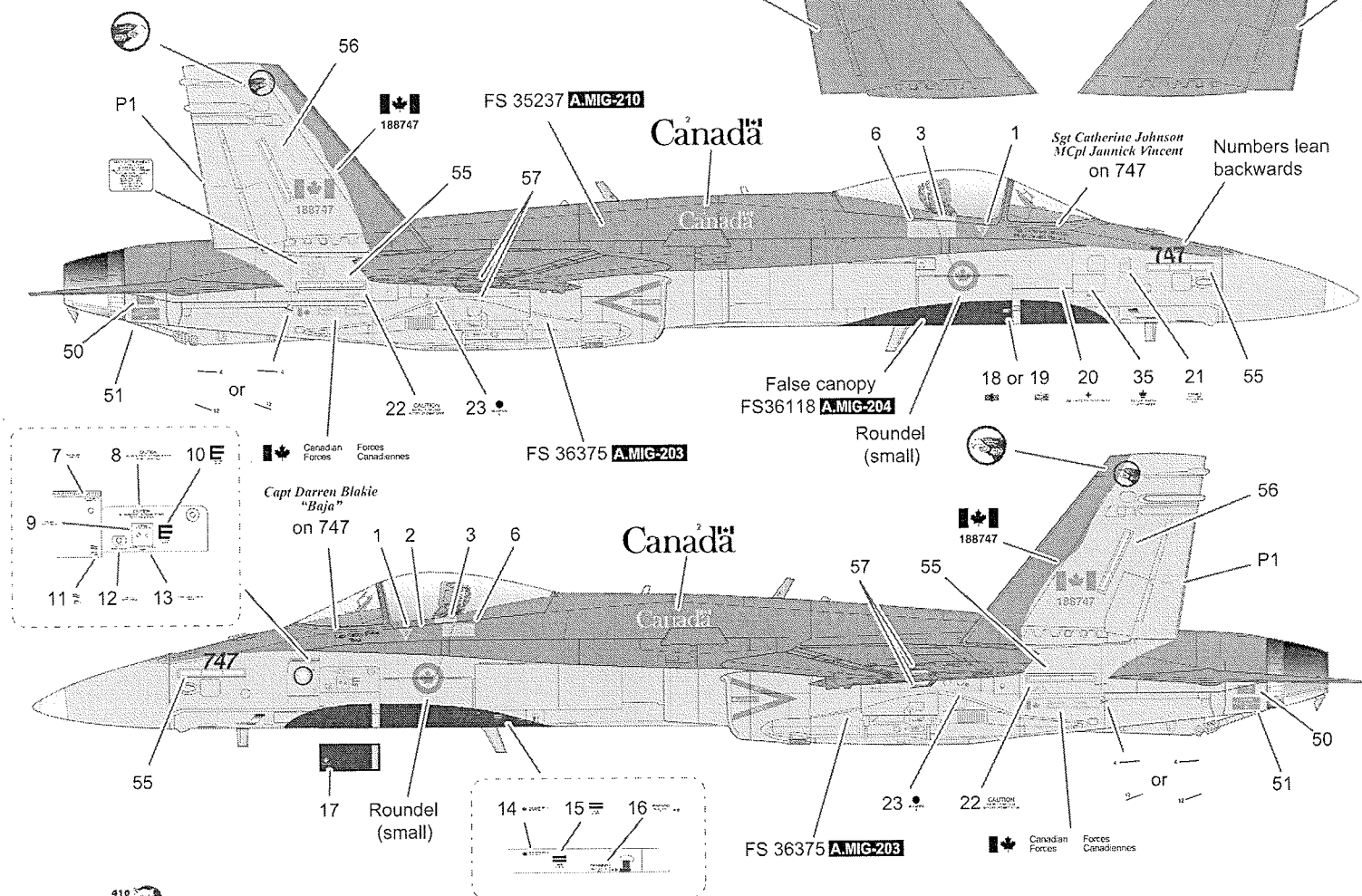
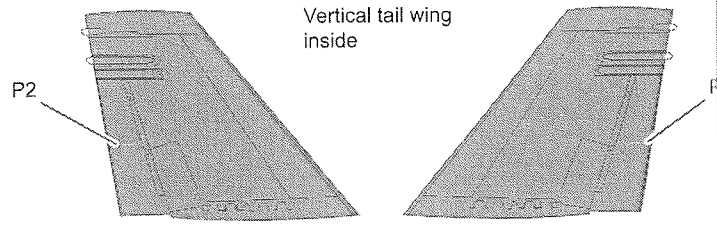

2. CF-188A/B, 410SQ, Canadian Air Force, Jun, 2016.

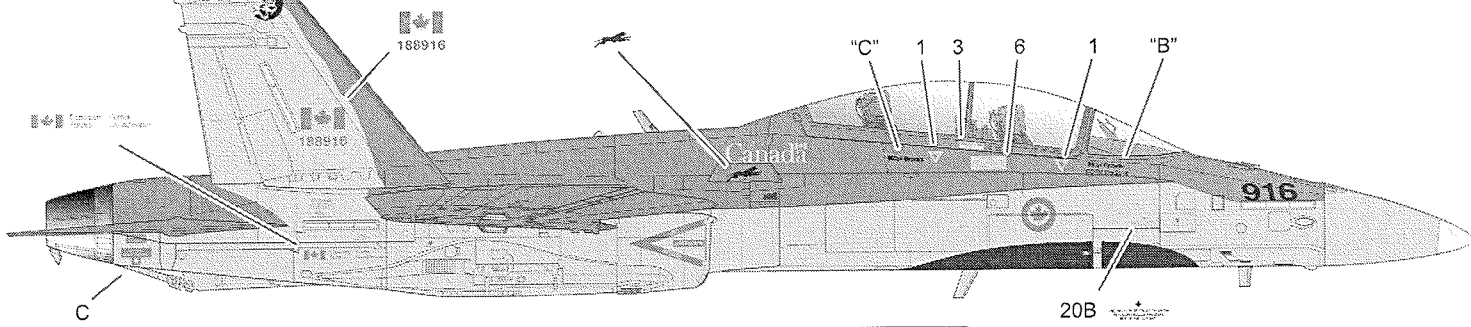

A/C No.	188916	188932	188937	188938
"A"	Capt Myers "Sleik"	Capt Park "Walker"	Capt Gulbat "Whaler"	Capt Walker "Stork"
"B"	CMpl Fichelle COTM Oct 2014	Cpl Belanger	MCpl Hill FPC 53	Sgt Poole
"C"	MCpl Brooks		Cpl Fisher	Cpl Northcott

Provided CF-188B
(double seater)
serial / crew names

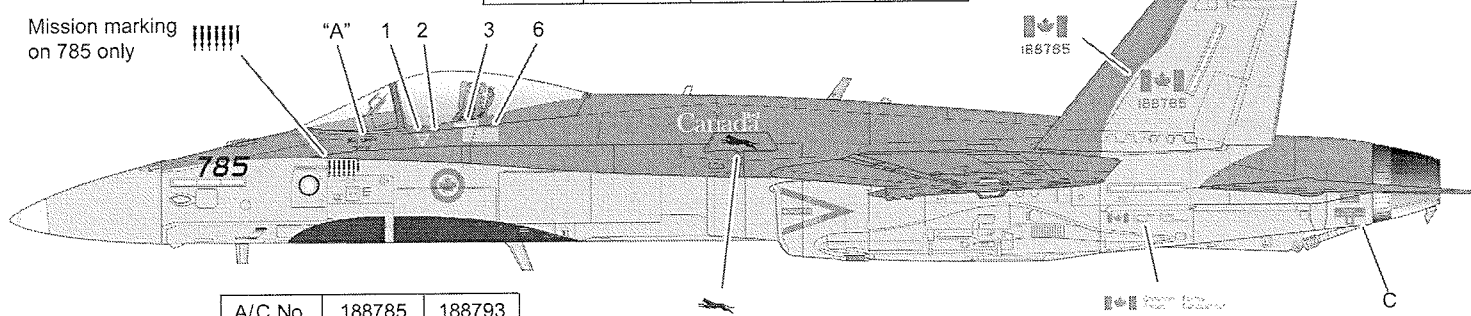

Provided CF-188A
(single seater)
serial / crew names

A/C No.	188785	188793
"A"	Maj Lewis "Singe"	Capt Hannam "Lyon"
"B"	MCpl Robitaille COTM Apr 2015	

3. CF-188A/B, 425SQ, Canadian Air Force, 2015.

Options provided: 188756, 188788, 188797 (CF-188A) and 188917 (CF-188B)
 Some combination on numbers may be required, and other markings are identical with other SQNs.

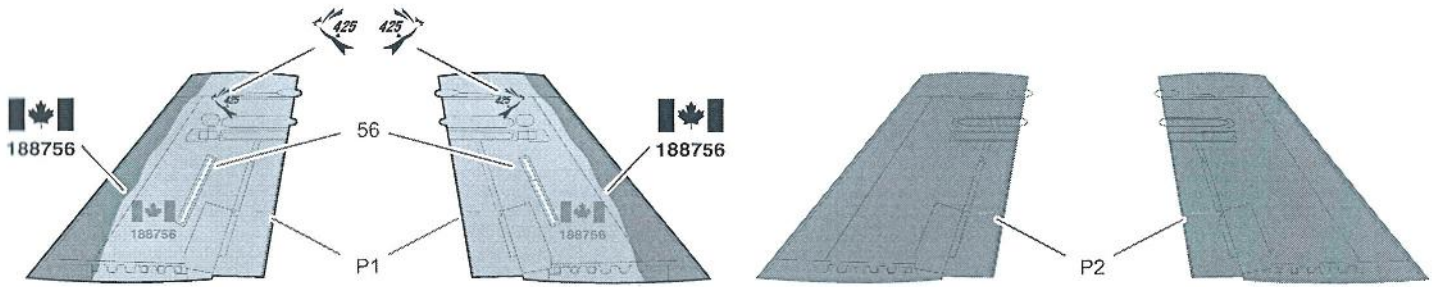

4. F/A-18A A21-35, NO.75SQ, Royal Australian Air Force, 2015 Australian International Airshow Special scheme.

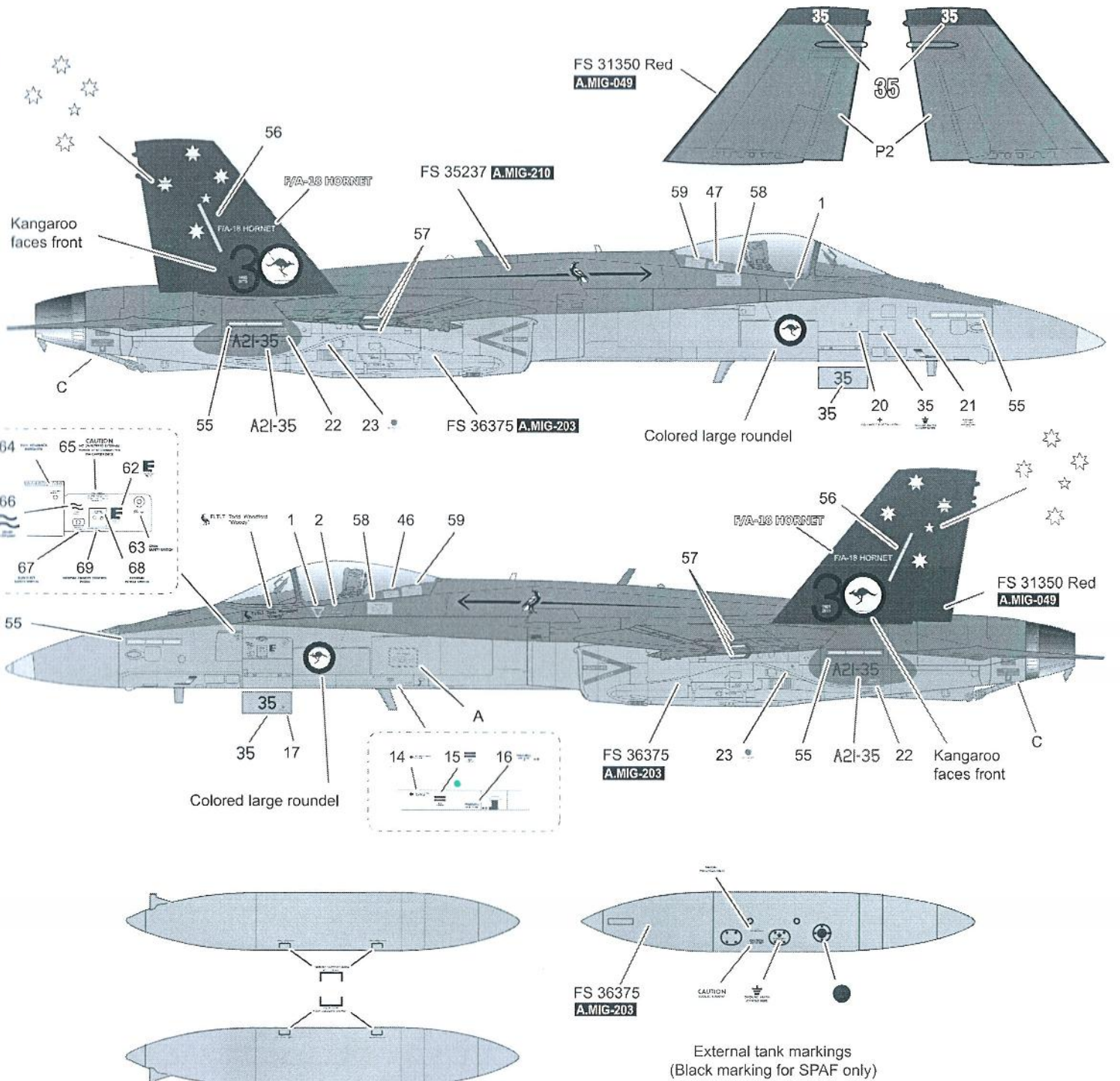

5. F/A-18A A21-4, NO.77SQ, Royal Australian Air Force, 2014.

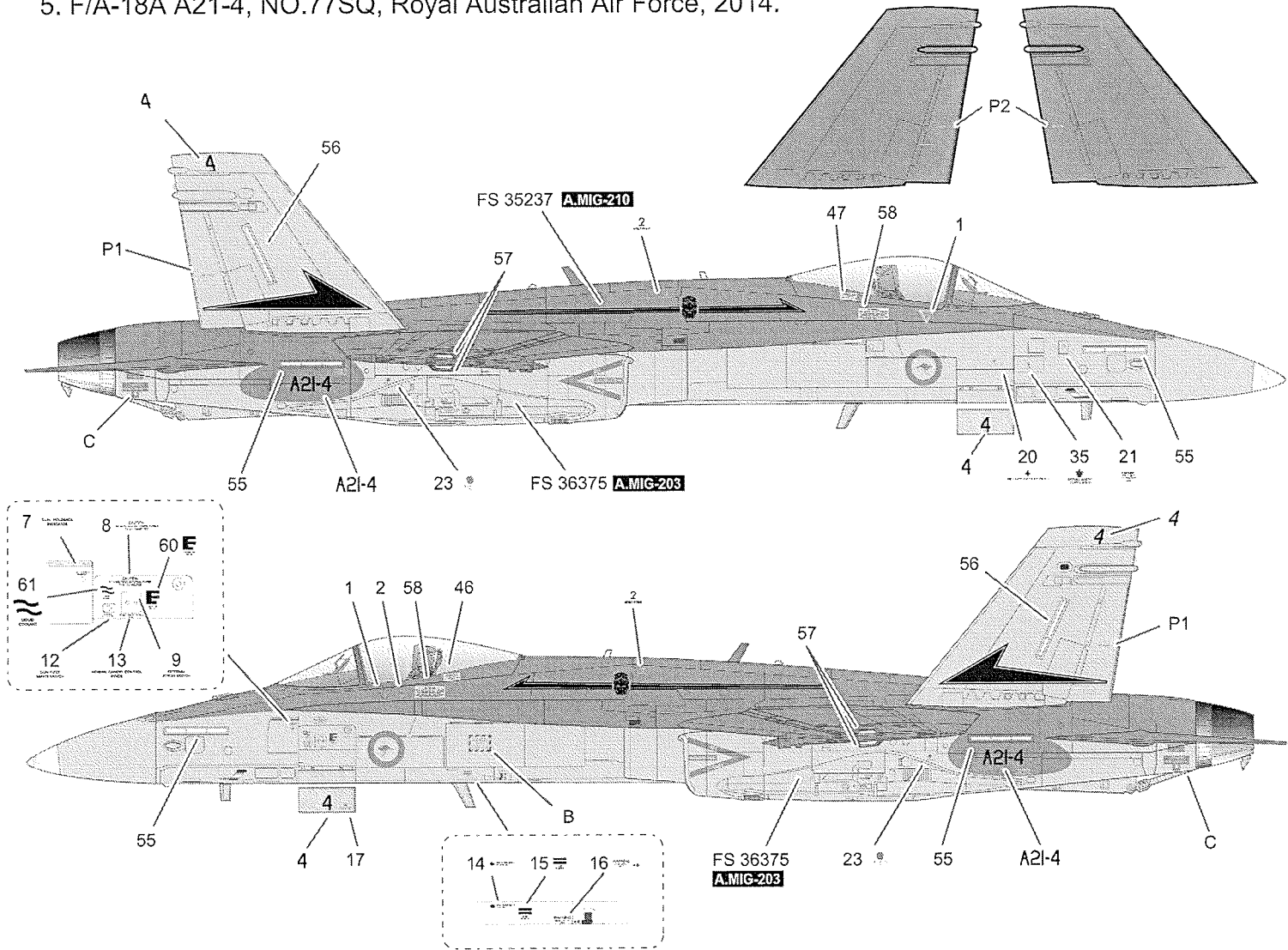

6. F/A-18A A21-57, NO.3SQ, Royal Australian Air Force, Operation OKRA against ISIL, 2015.

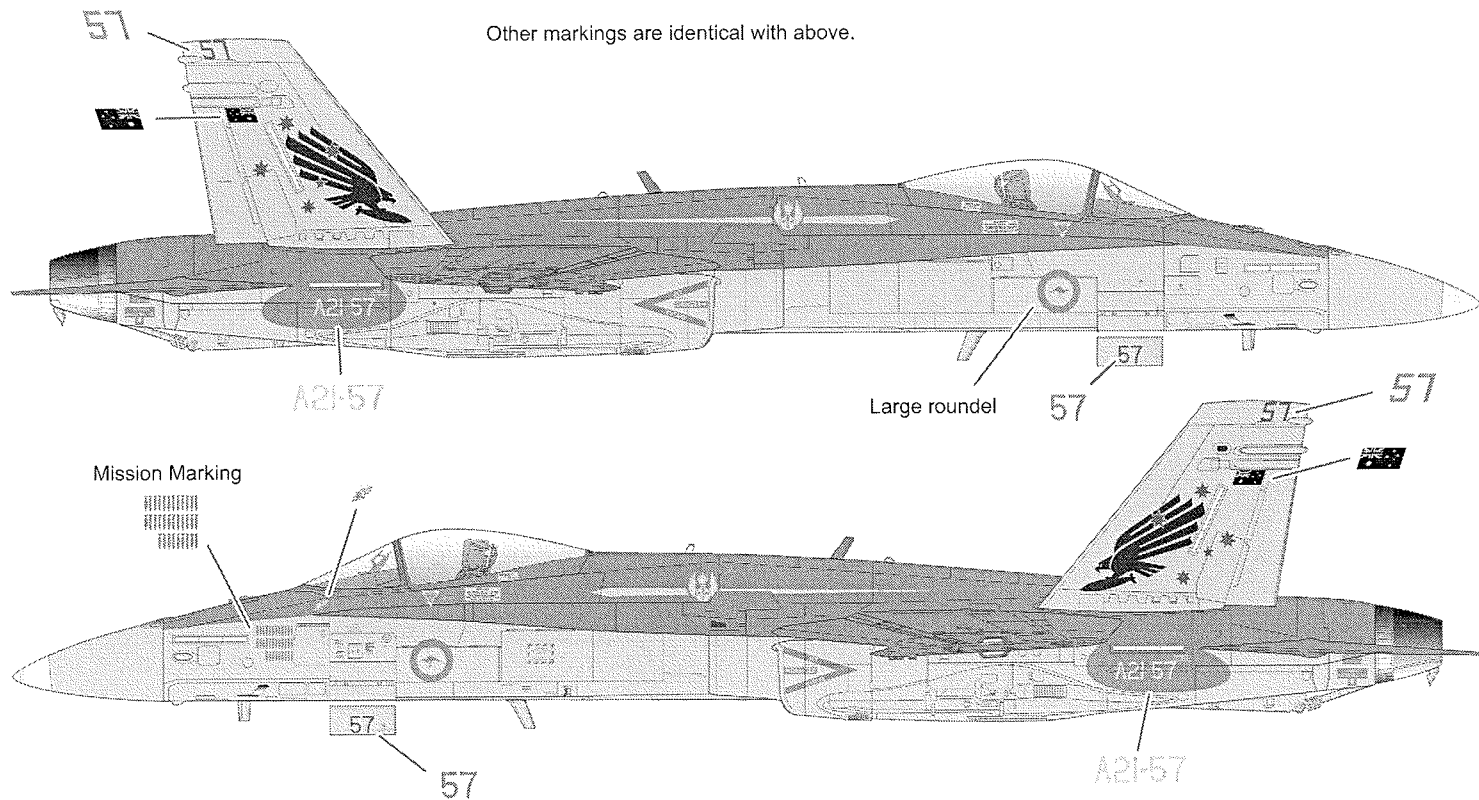

7. EF-18AM C.15-25, Ala 15, Spanish Air Force,
Anatolian Eagle exercise in Konya, Turkey, 2015.

All SPAF aircraft indicated here are equipped with catapult launchbar on nose gear but IFF antenna "Bird slicer" have NOT been installed in front of the canopy

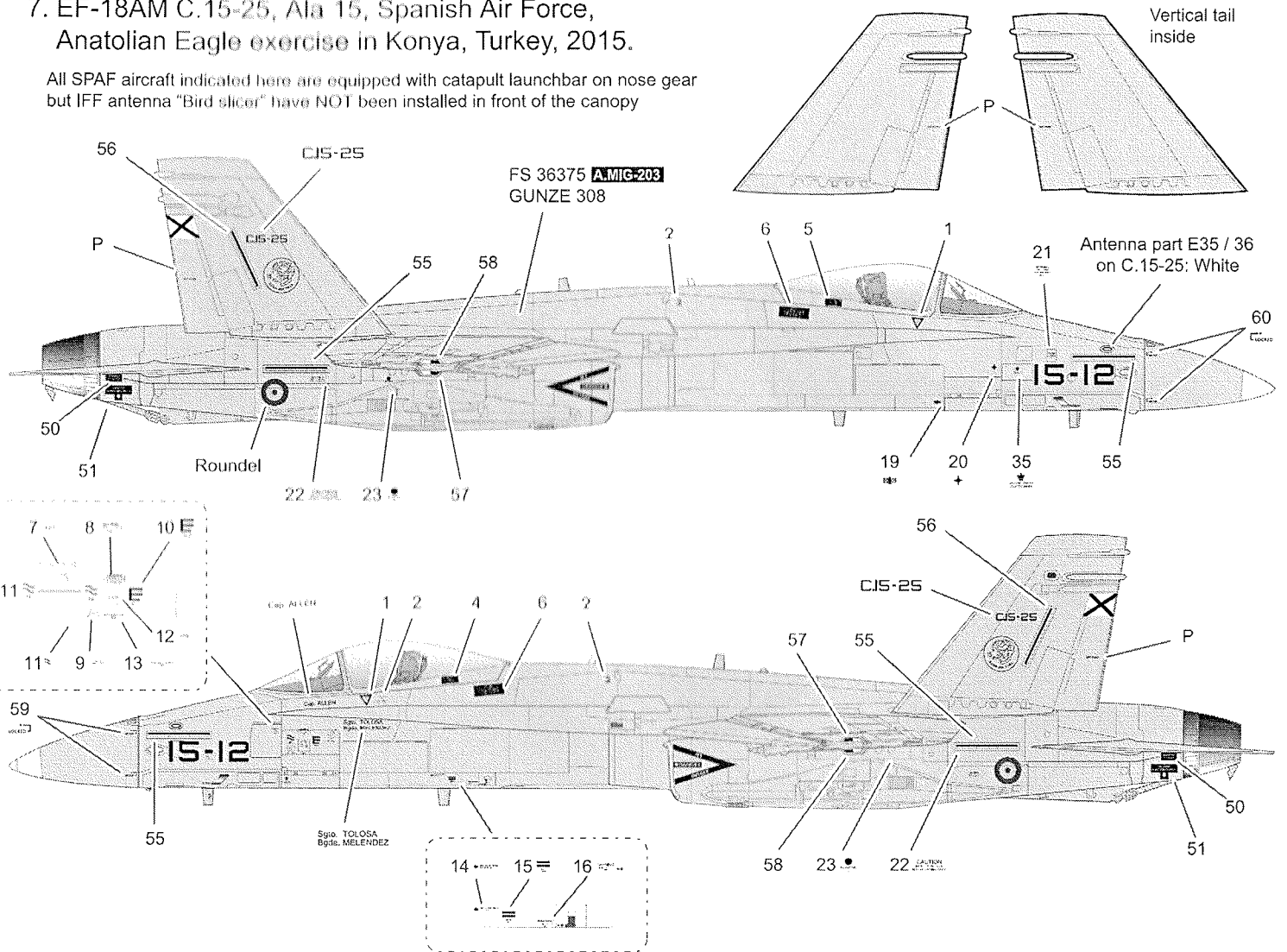

8. EF-18AM C.15-50, Ala 12, Spanish Air Force, 2016.

Other markings are identical with above

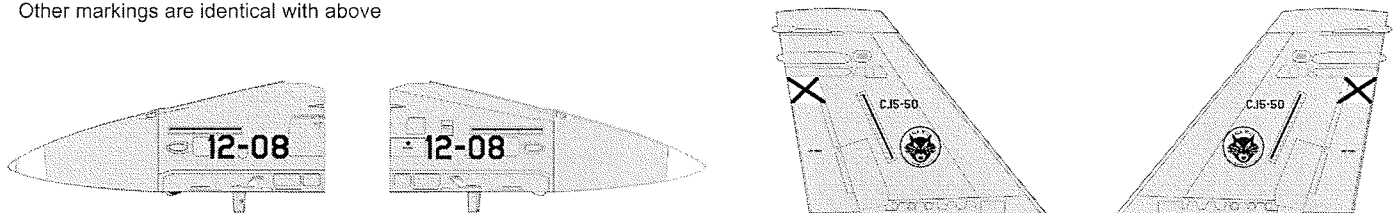

9. F/A-18A+(ex US Navy) C.15-85, Ala 46, Spanish Air Force, 2016.

Other markings are identical with above

No "Black Bar" on formation light
Also use no.57 for wingtip light

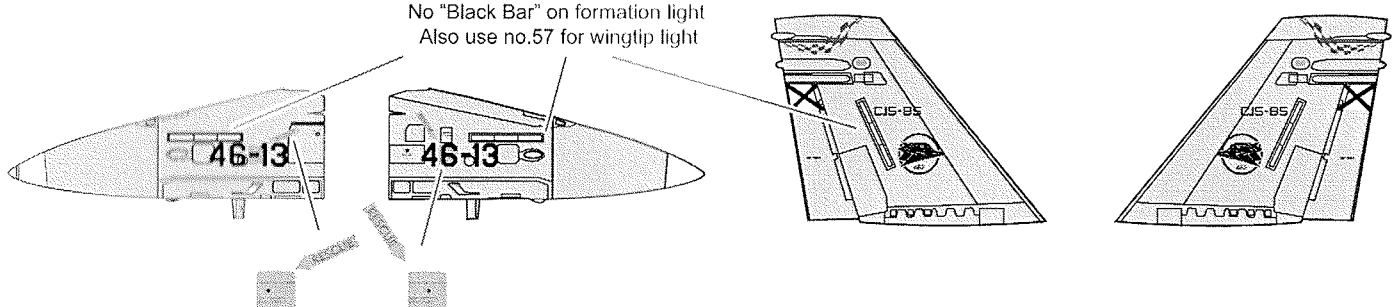

10. CAF / RAAF Colors

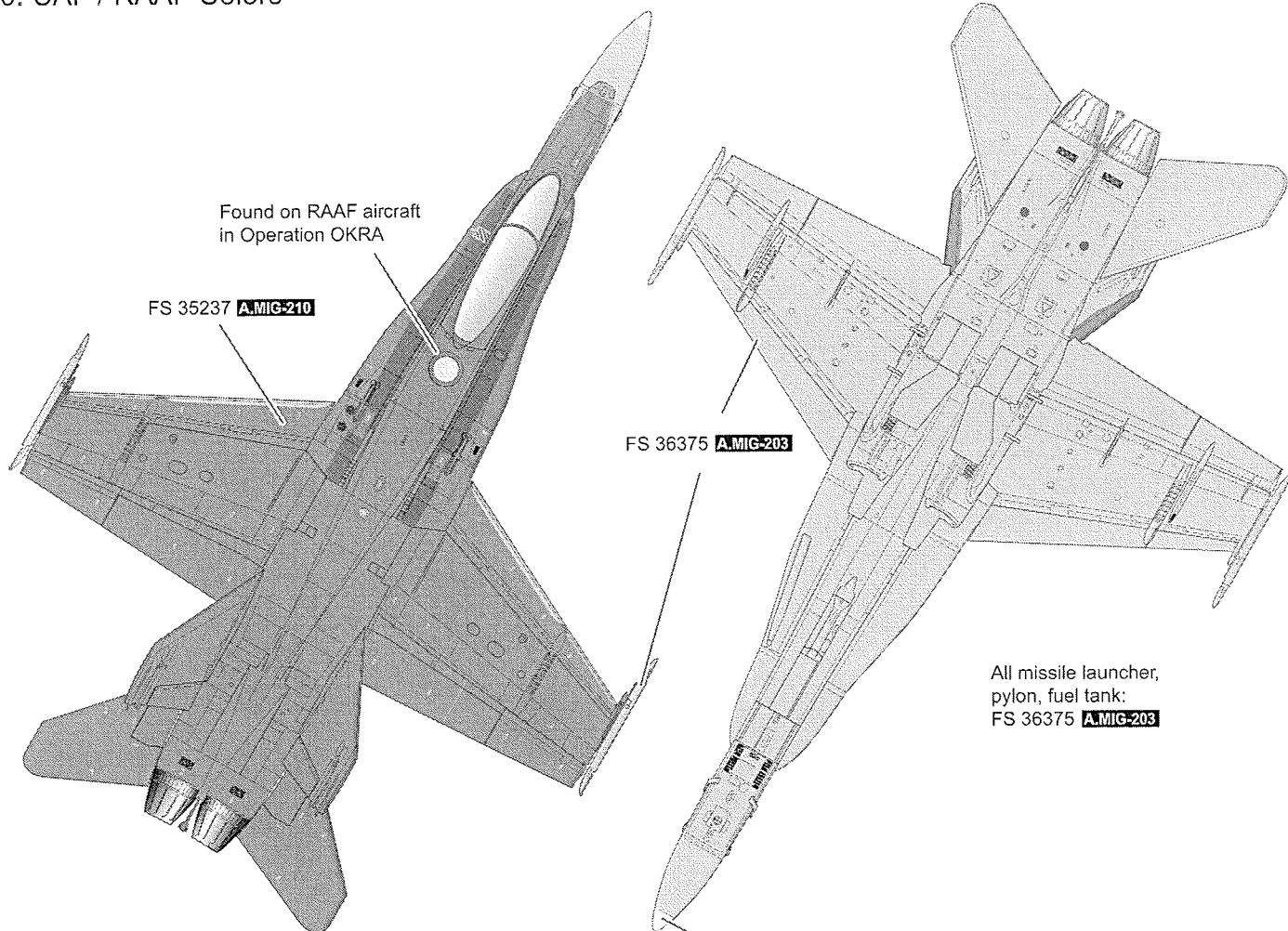

11. SPAF Colors

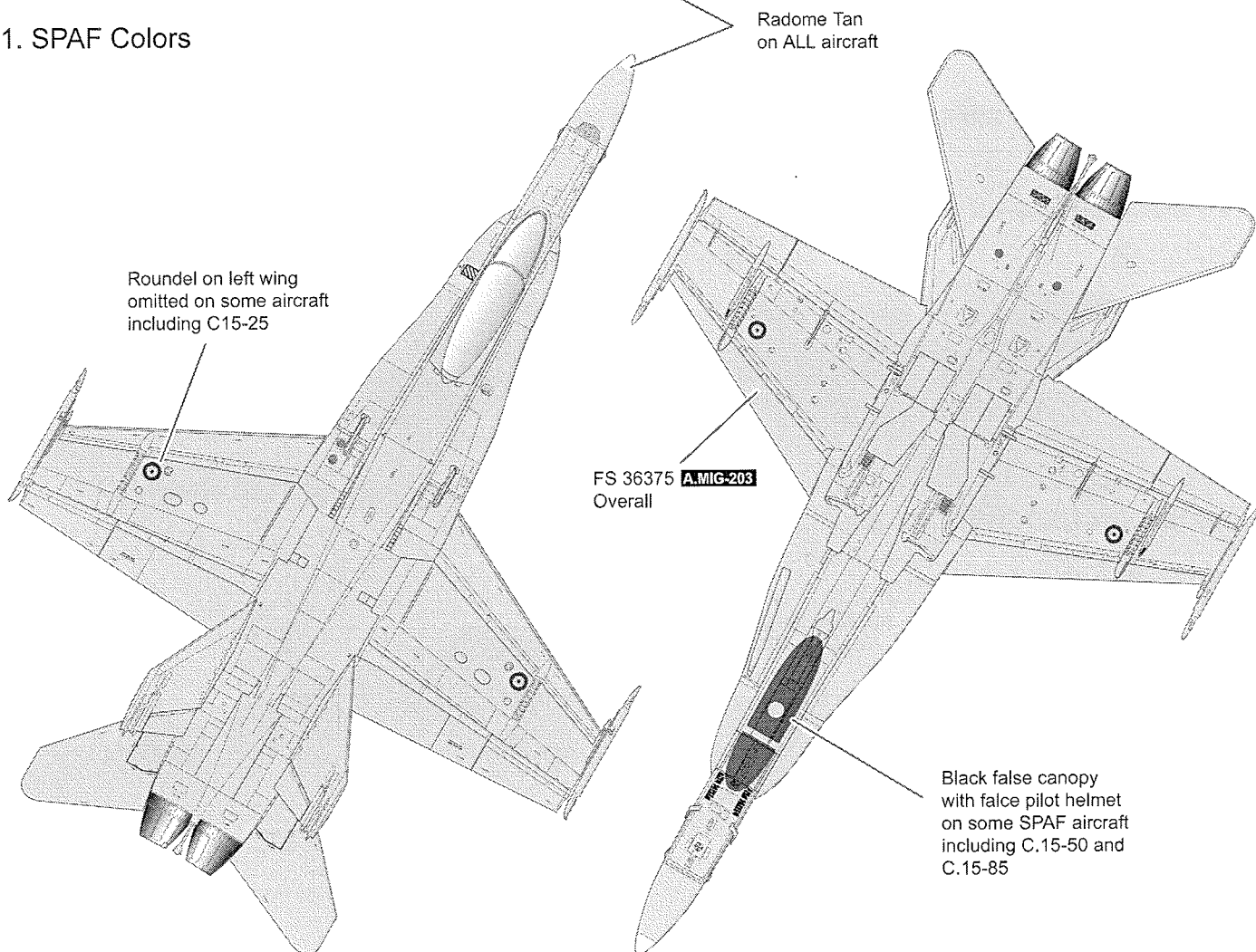



16 7 8 32 56 88 97
16 7 8 32 56 88 97
794 794 3 3 85 85 747 747 917 917 916 7 7 8 8 32 32
794 794 3 3 85 85 747 747 917 917 916 56 56 88 88 97 97
188785 188785 188747 188747 188916 188916 17 17 32 32 37 37 38 38 56 56 88 88 93 93 94 94 97 97

Capt Darren Blakie "Baja" Sgt Catharin Johnson MCpl Jannick Vincent Maj Lewis "Stinger" MCpl Robitaille COTM Apr 2015
Capt Hannam "Tyson" Capt Myers "Slob" CMpl Pichelle COTM Oct 2014 MCpl Brooks Capt Park "Trailer" Cpl Belanger Capt Guibat "Whaler" MCpl Hill FPC 53 Cpl Fisher Capt Walker "Shrek" Sgt Poole Cpl Northcott
A21-35 A21-35 35 35 35 35 A21-4 A21-4 4 4 4 4 A21-57 A21-57 57 57 57 57 FLTLT Todd Woodford "Woody"

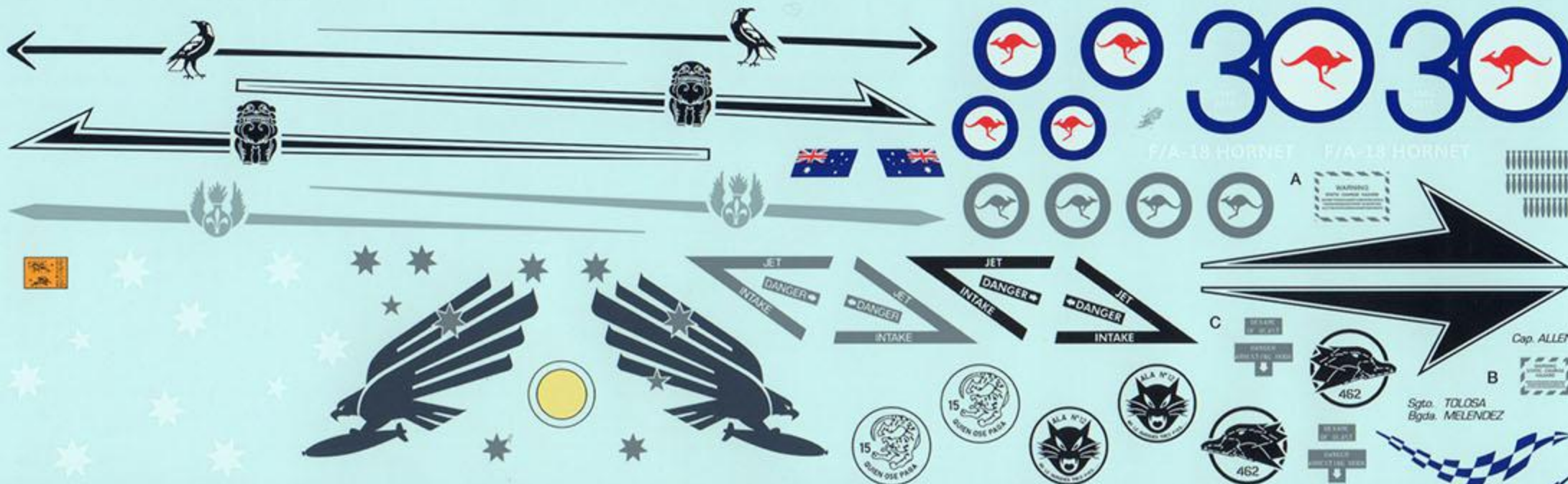

15-12 15-12 12-08 12-08 46-13 46-13 C.15-25 C.15-85 C.15-50
C.15-25 C.15-85 C.15-50

1 1 2 2 3 3 4 4 5 5 6 6 7 7 8 8 9 9 0 0

1 1 2 2 3 3 4 4 5 5 6 6 7 7 8 8 9 9 0 0 1 2 3 4 5 6 7 8 9 0 1 2 3 4 5 6 7 8 9 0 X X

