

# Hawker Tempest F.6

## Historie

Hawker Tempest (v angličtině bouře) byl velmi výkonným britským jednomotorovým stíhacím letounem druhé světové války. První sériový Tempest Mk.V (JN729) byl zalétán 21. června 1943. Již od počátku výroby byly Mk.V vybaveny kapkovitým krytem kabiny a čtyřnadvacetiválcovým řadovým motorem Napier Sabre IIA o vzletovém výkonu 1603 kW. Prvních sto kusů Mk.V Series 1 bylo vyzbrojeno čtveřicí kanónů British Hispano Mk.II instalovaných v křídle, jejichž hlavně o 0,2 m přesahovaly náběžnou hranu. Další Tempesty Mk.V Series 2 obdržely kanóny Hispano Mk.V s kratší hlavní. Tempesty byly poprvé bojově nasazeny začátkem května 1944 nad Francií při útocích na dopravní systém a letiště. Letadla Tempest aspirovala díky své rychlosti i ostatním vlastnostem na titul nejlepší stíhačky Royal Air Force.

Na verzi Mk.V navázala varianta **Tempest Mk.VI** (zálet 9. května 1944) se silnějším motorem Napier Sabre V o výkonu 1721 kW se vstupy vzduchu v kořenech křídla. Celkem bylo vyrobeno 142 kusů.

## History

The Hawker Tempest was a very powerful British single-engine fighter aircraft of World War II. The first serial Tempest Mk.V (JN729) was flown on June 21, 1943. From the beginning of production, the Mk.V were equipped with a teardrop-shaped cabin cover and a twenty-four-cylinder inline engine Napier Saber IIA with a takeoff power of 1603 kW. The first hundred pieces of the Mk.V Series 1 were armed with four British Hispano Mk.II cannons installed in the wing, whose barrel by 0.2 m exceeded the leading edge. Other Tempesty Mk.V Series 2 received Hispano Mk.V cannons with a shorter barrel. Tempests were first deployed in combat in early May 1944 over France during attacks on the transport system and airports. Thanks to its speed and other characteristics, Tempest aircraft aspired to the title of the best Royal Air Force fighter.

Various engineering refinements that had gone into the Tempest II were incorporated into the last Tempest variant, design nated as the *Tempest VI*. This variant was furnished with a Napier Sabre V engine with 2,340 hp (1,700 kW).



OPTIONAL  
VOLITELNĚ



DRILL HOLE  
VYVRTAT



SYMMETRICAL  
SYMETRICKY



REMOVE  
ODSTRANIT

# Assembly instructions

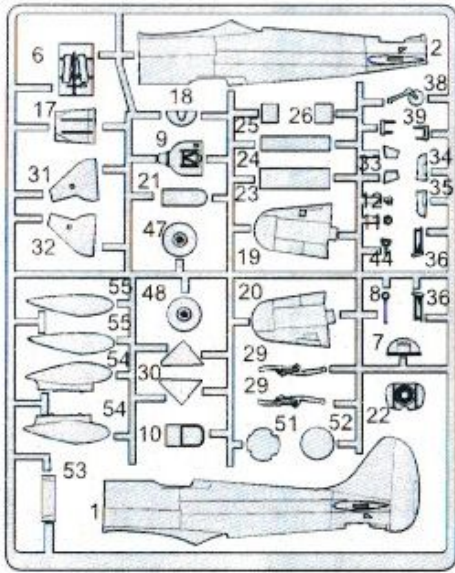

Plastikové díly/  
Plastic parts

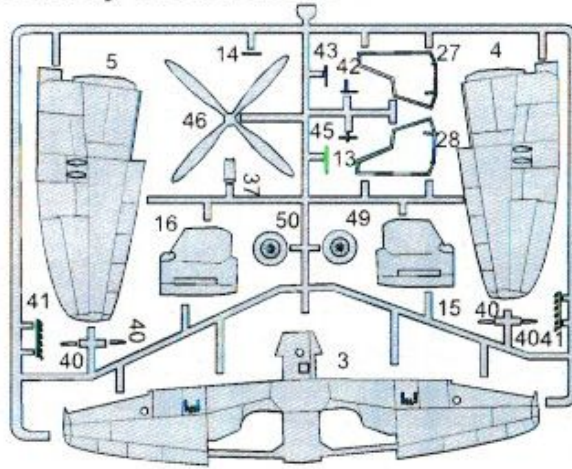

Průhledné díly/  
Clear parts

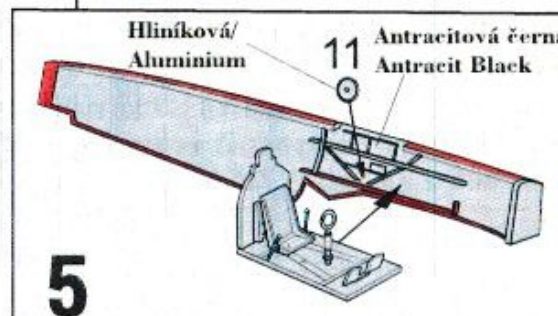
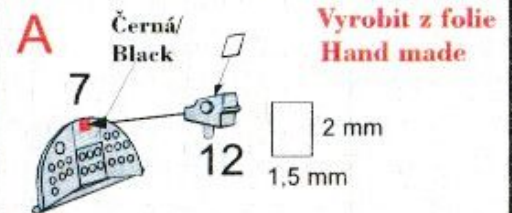
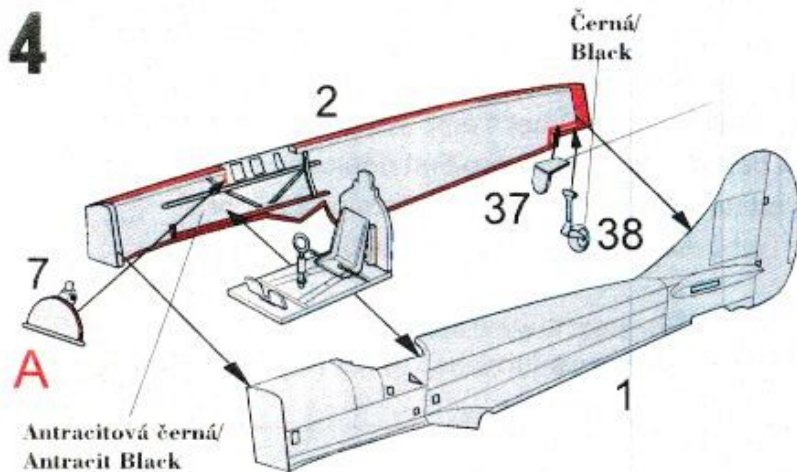
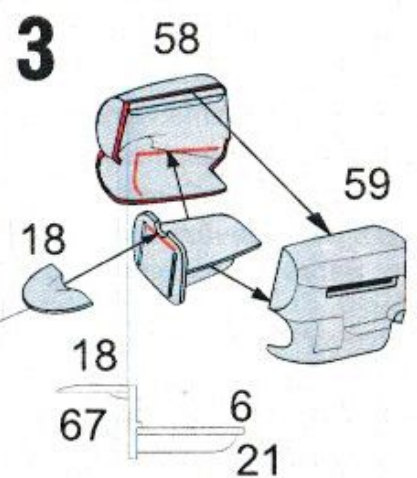
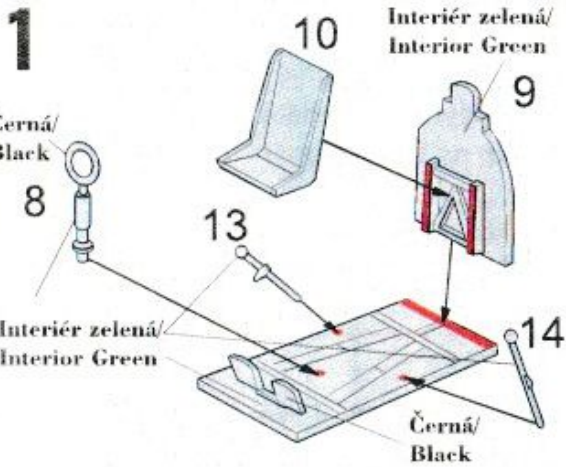
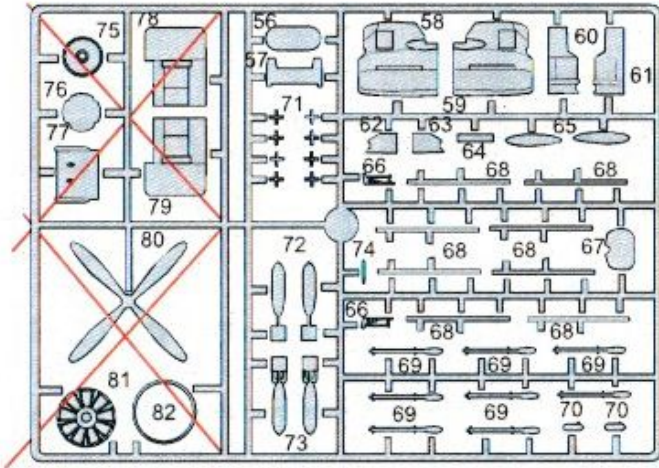
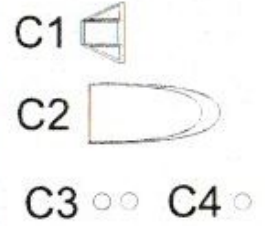

6

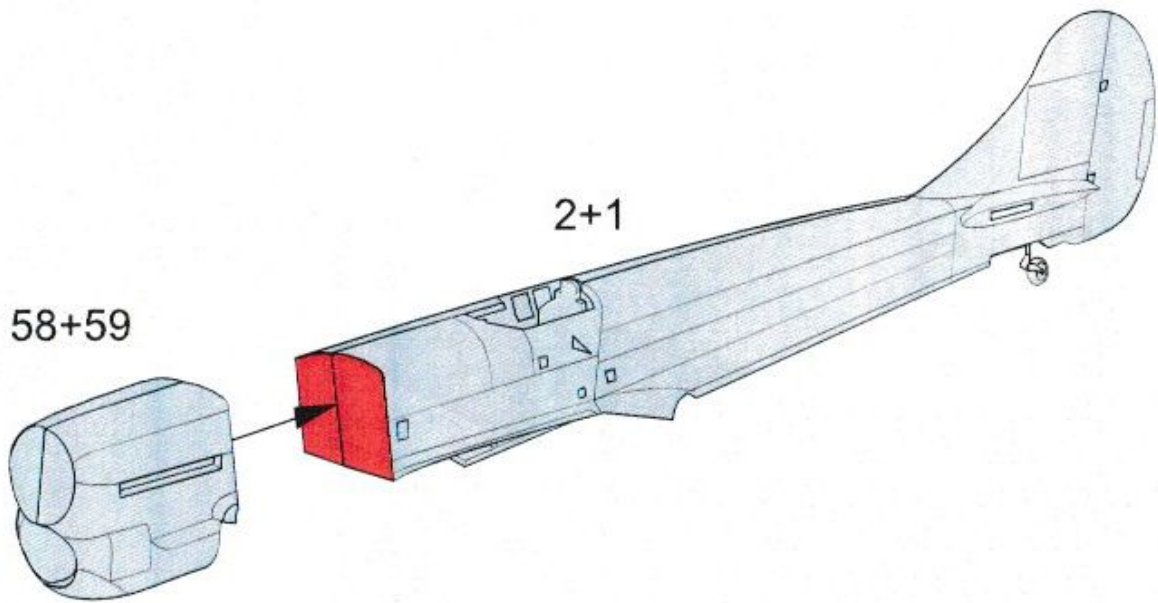

8

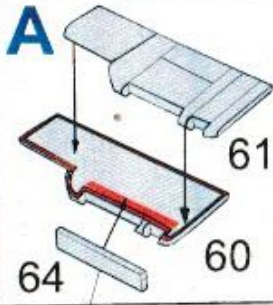

Černá/  
Black

A 7

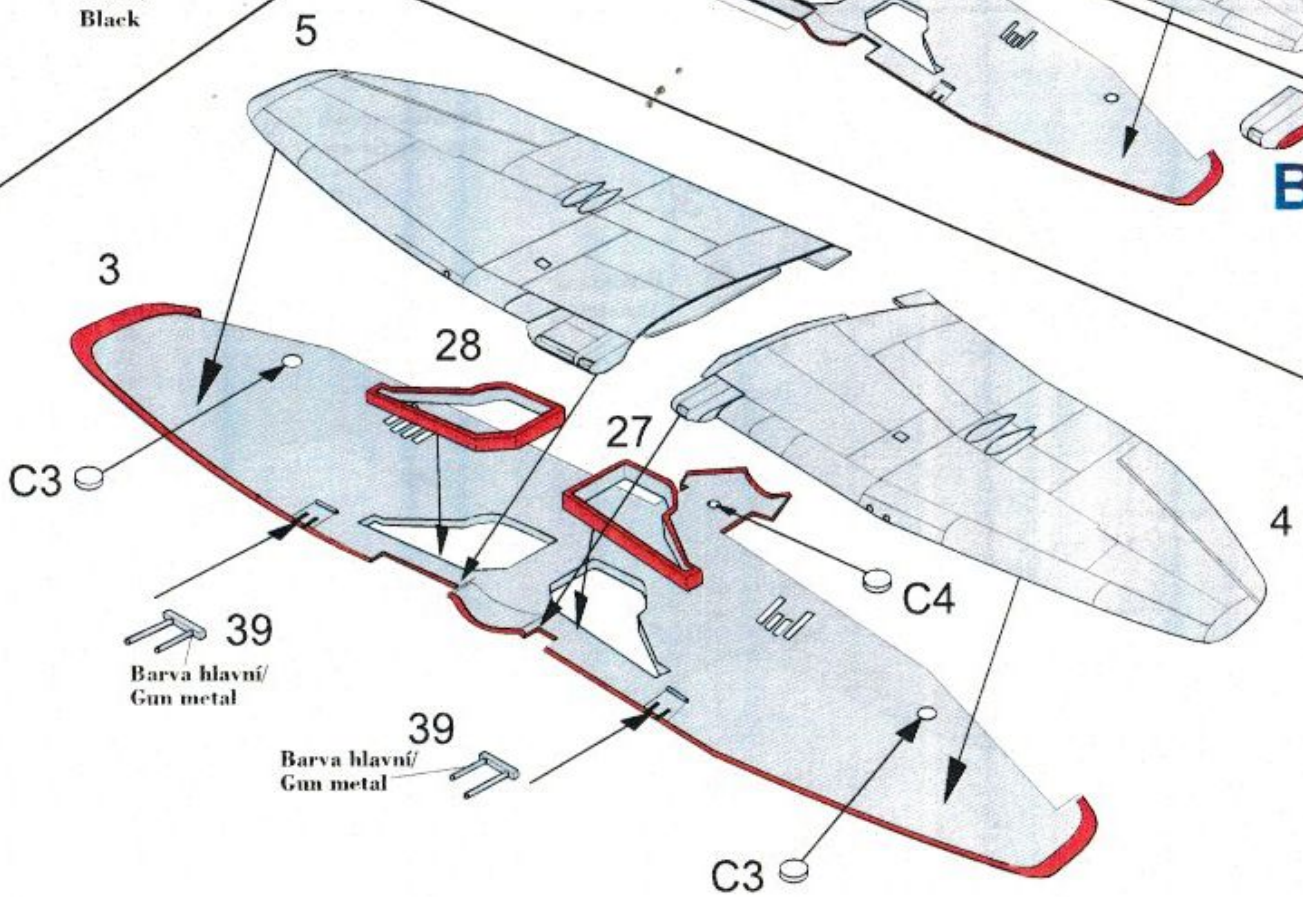
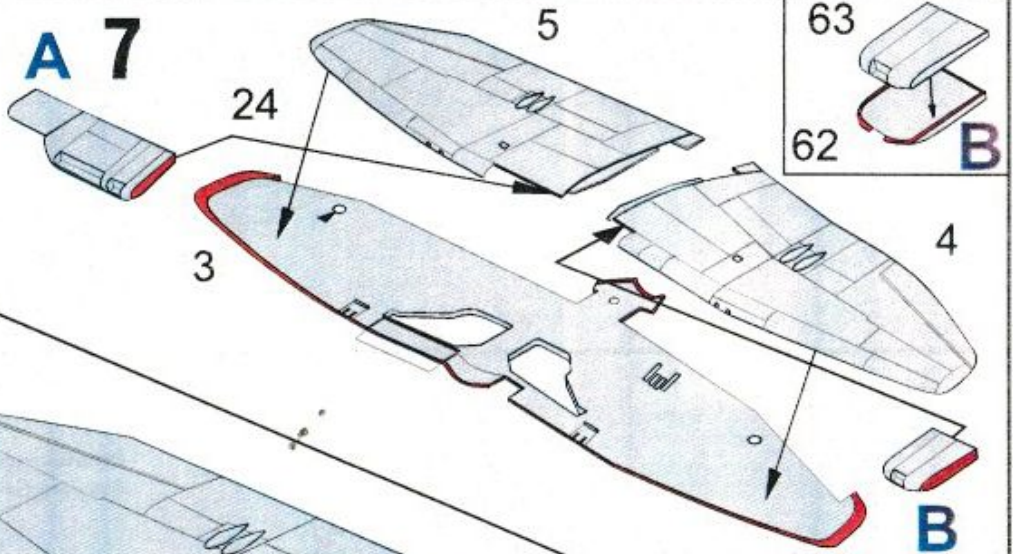

39  
Barva hlavní/  
Gun metal

39  
Barva hlavní/  
Gun metal

9

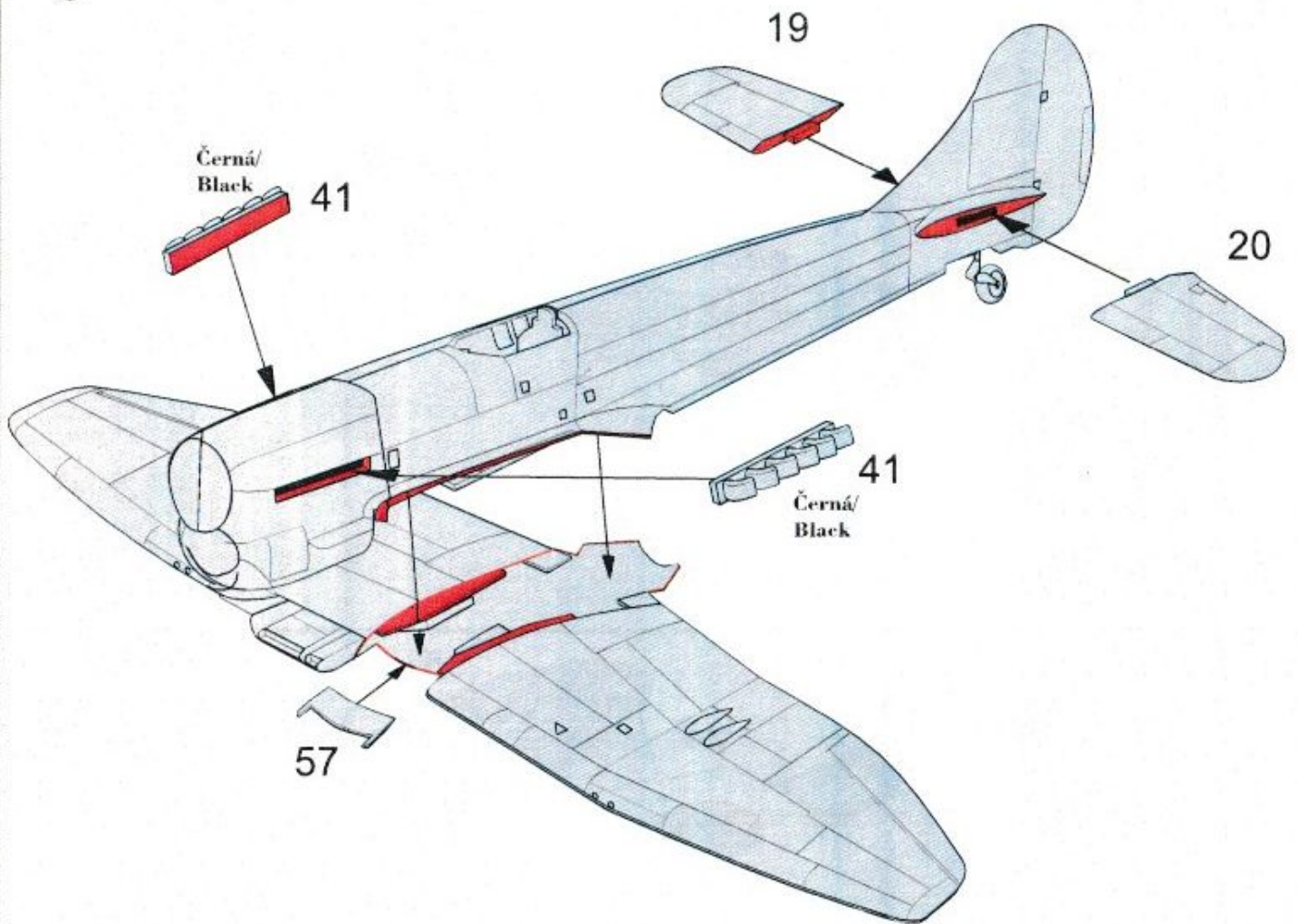

10

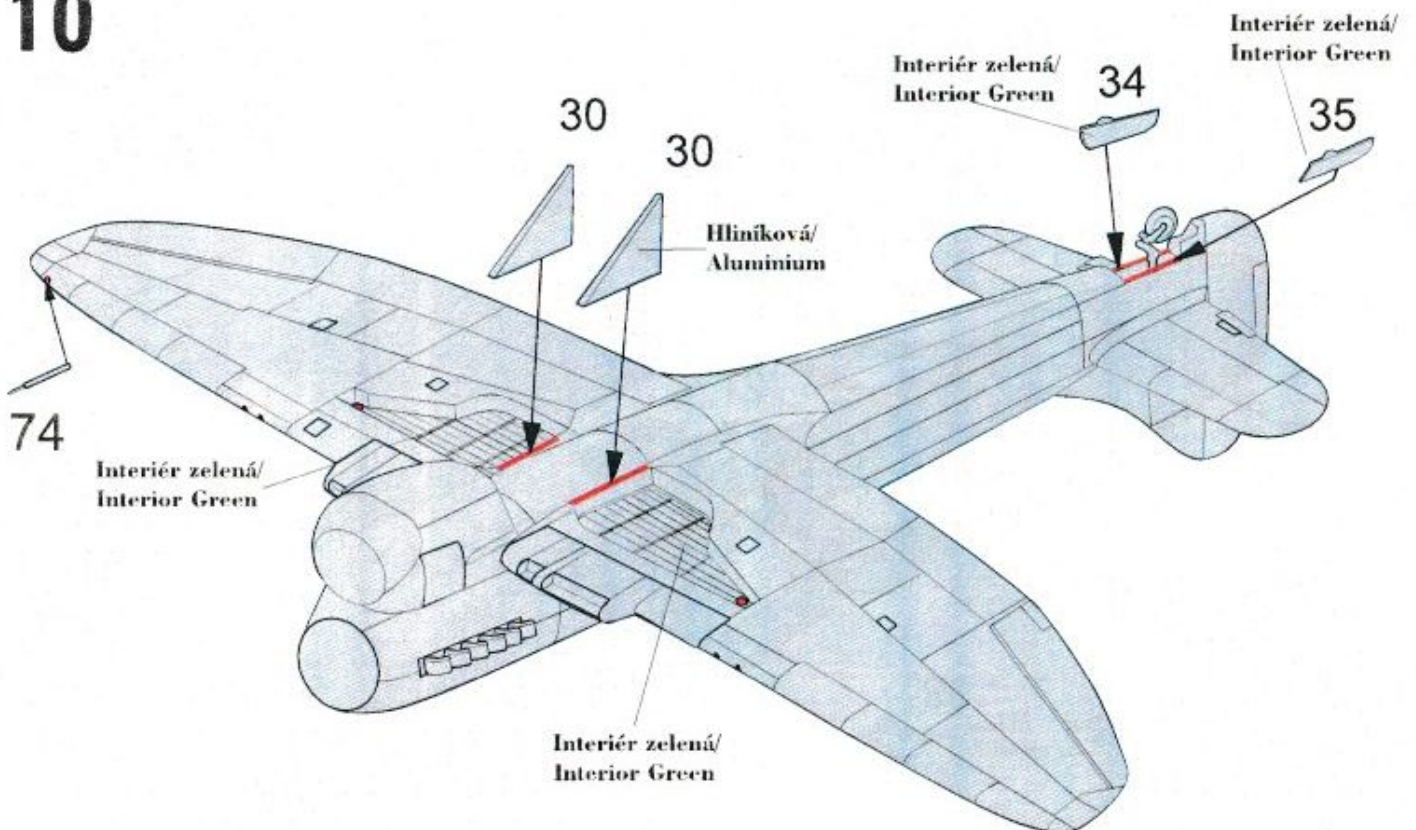

Assembly instructions

11

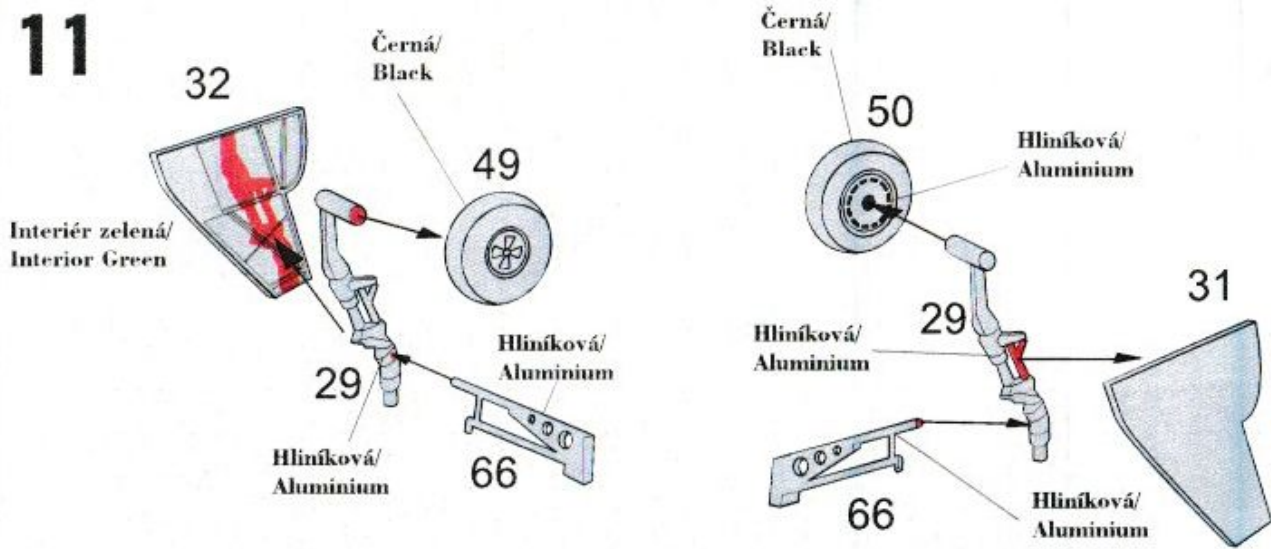

12

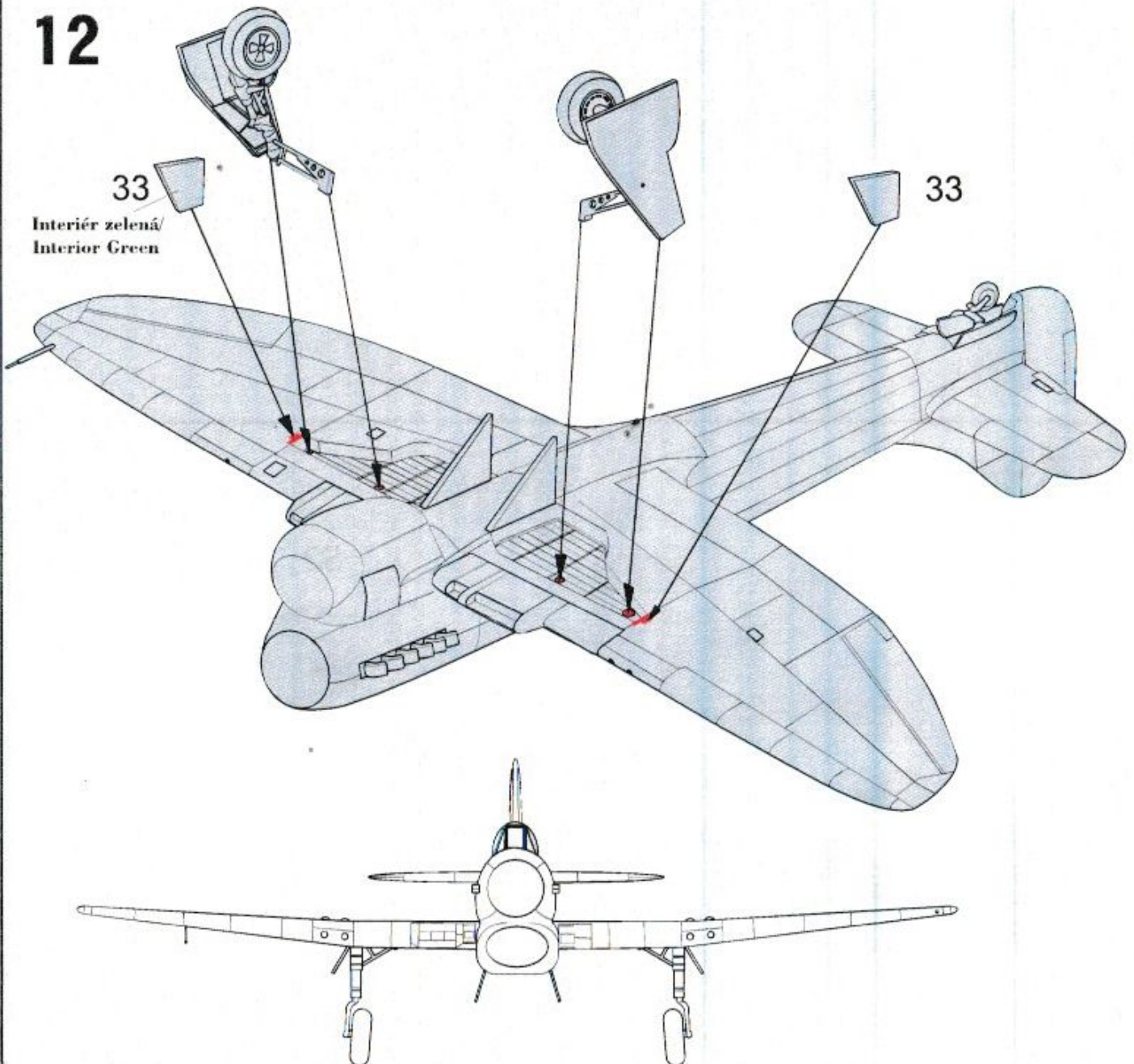

13

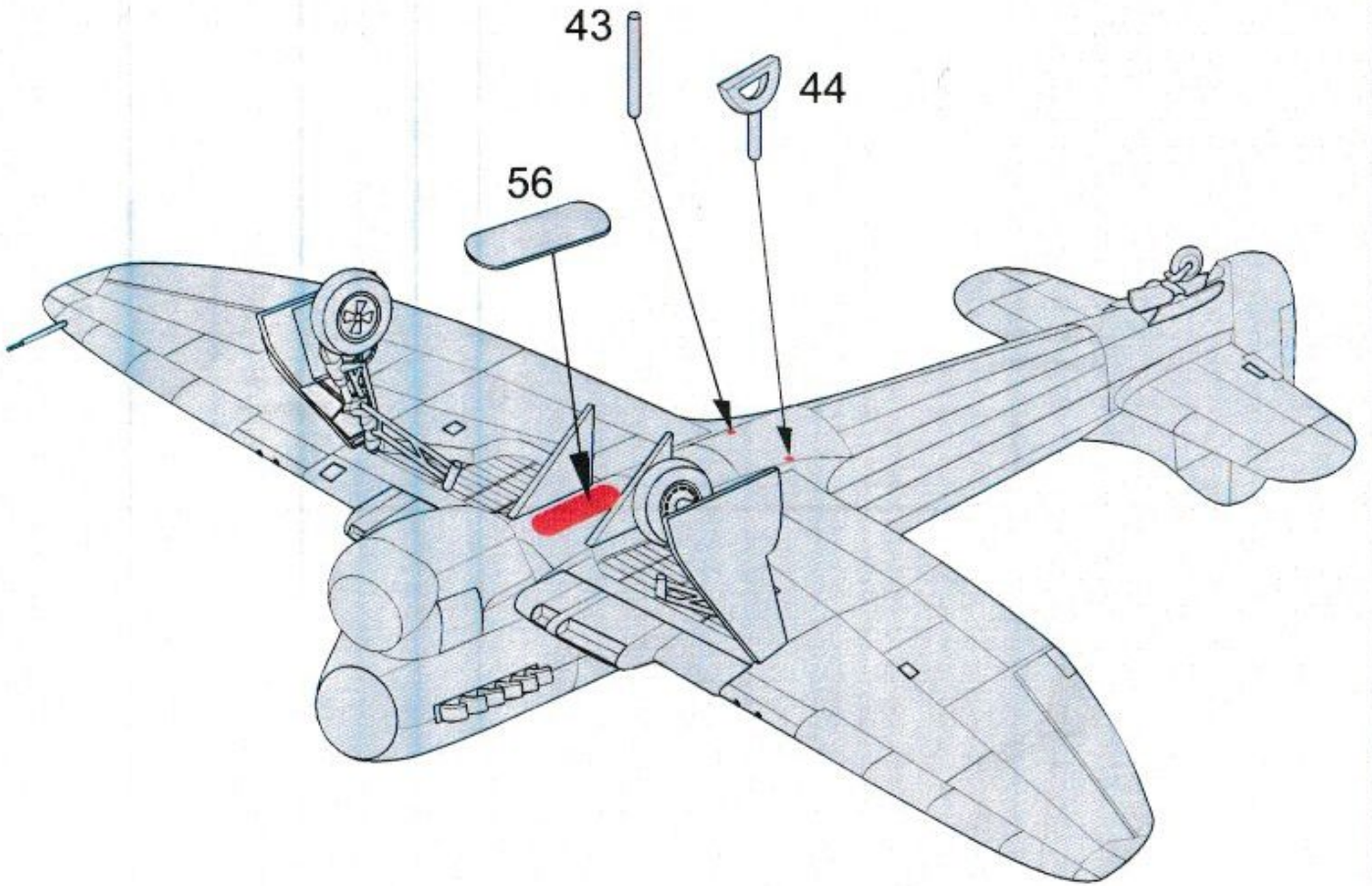

14

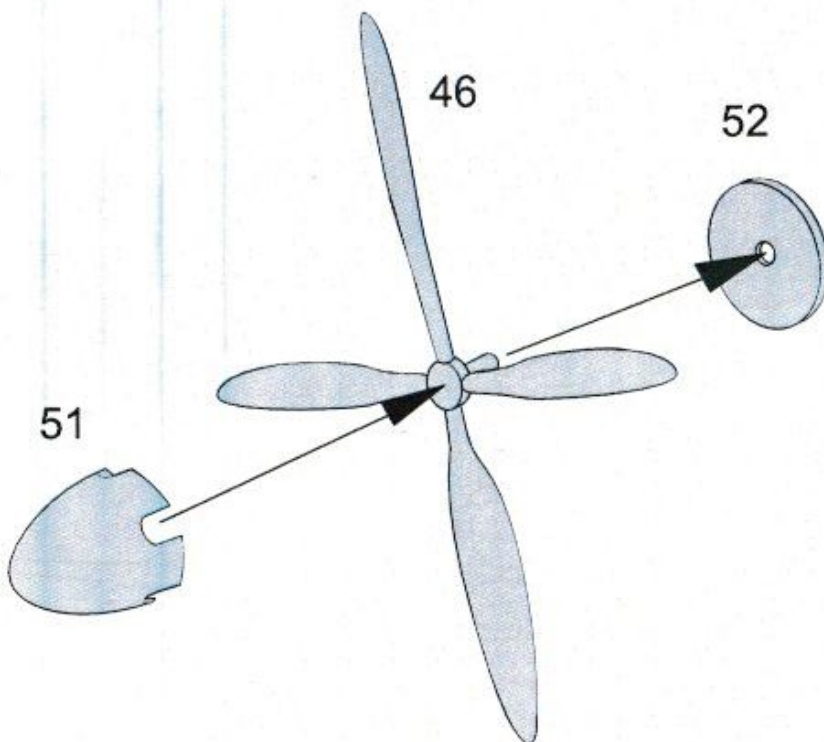

15

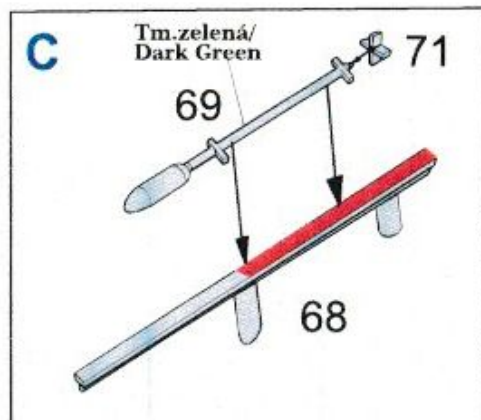
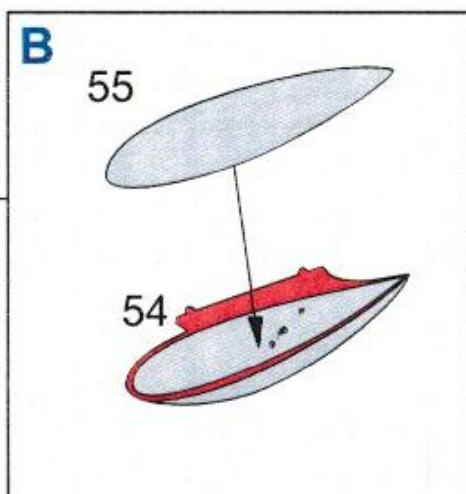
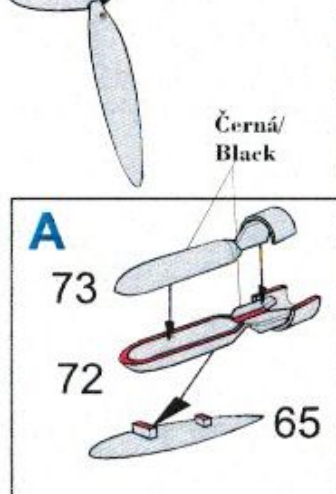
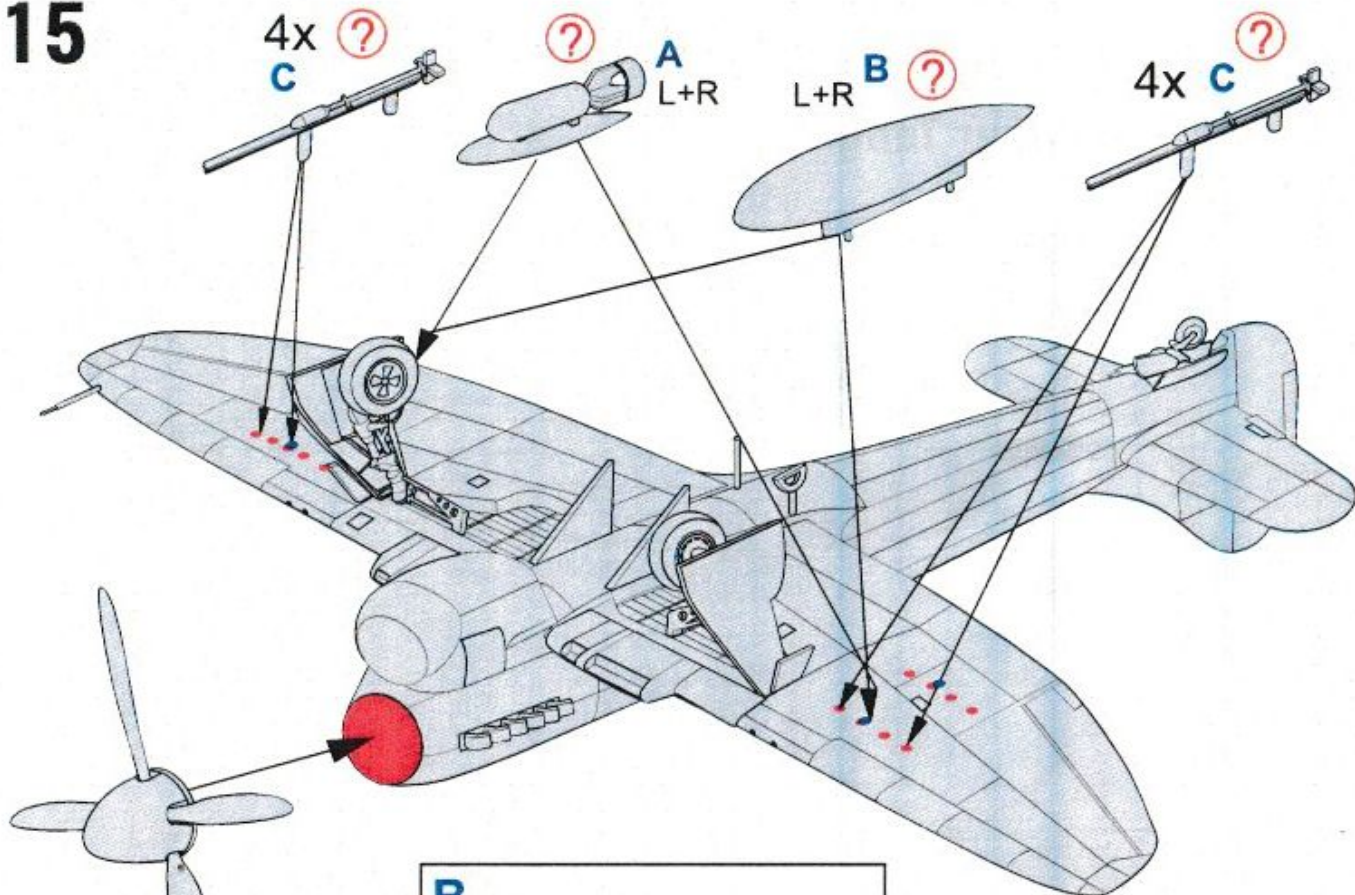

16

C1+C2

Žlutá/  
Yellow

70 70

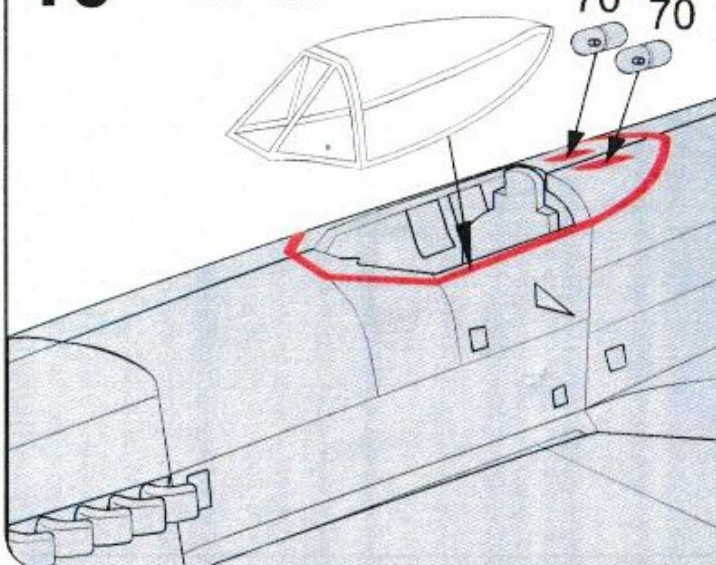

17

C1

C2

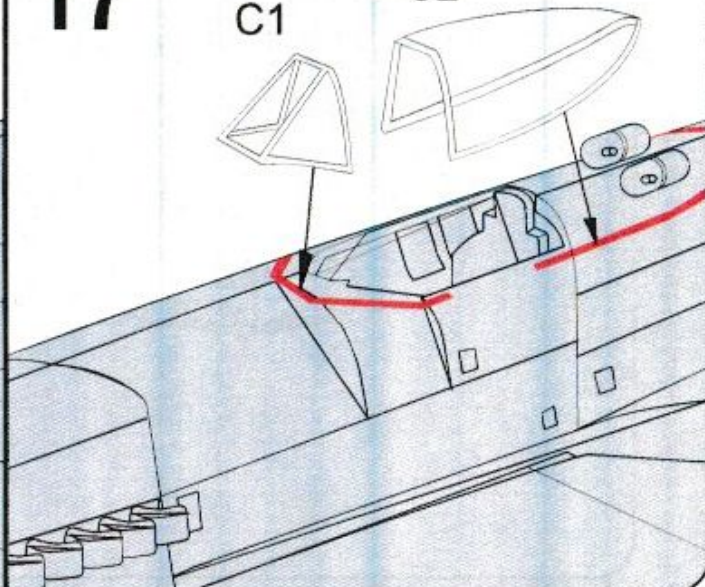

# 18

## Hawker Tempest F.6

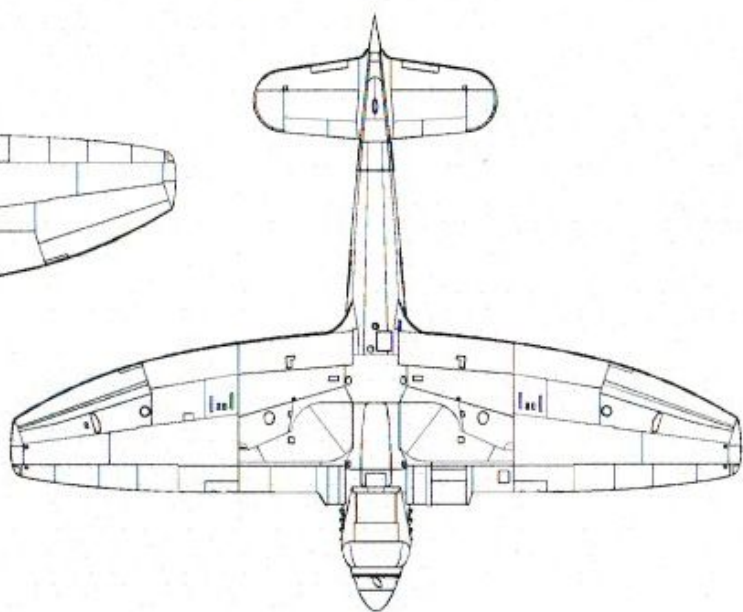
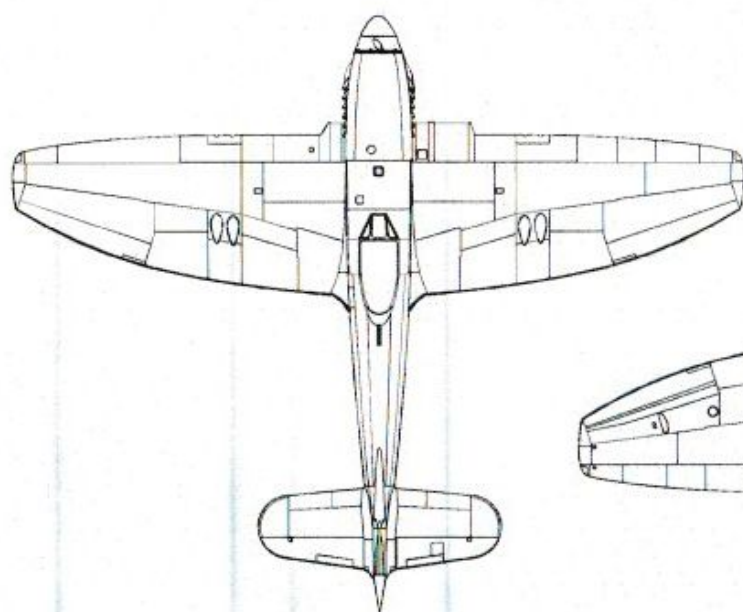
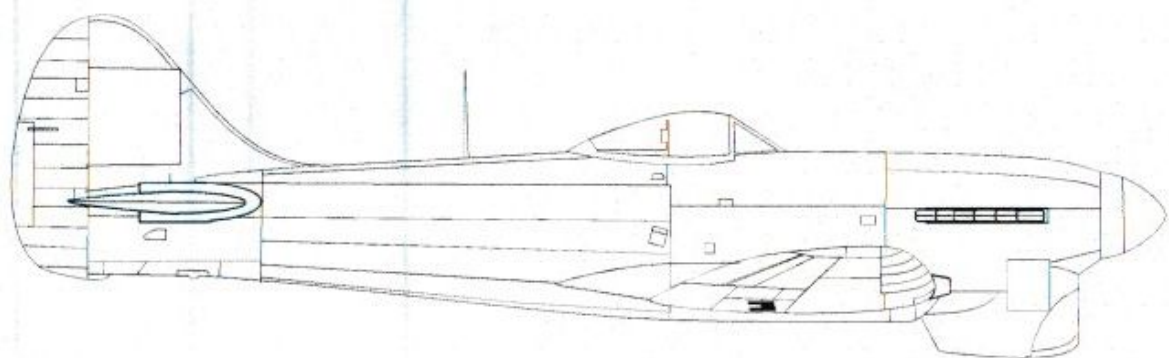
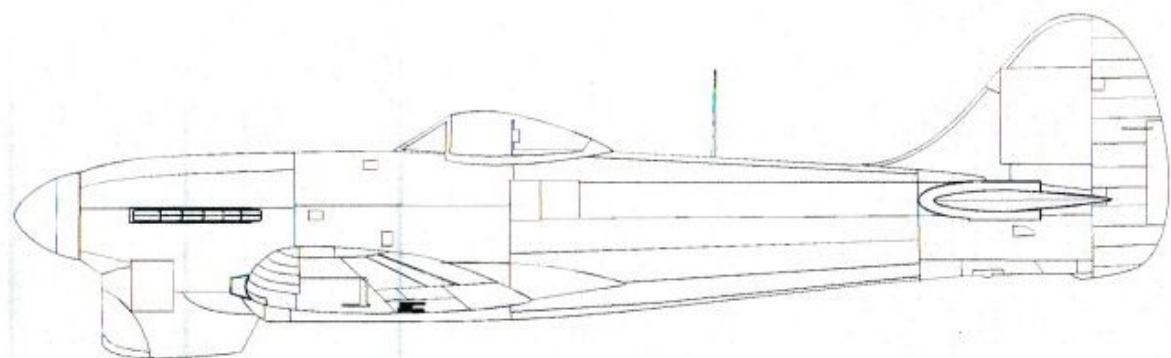



## Colours & Markings

1



Hawker Tempest F.6, NX247, H, 39. perut' RAF, základna Chartúm, Sudán, 1949.  
Hawker Tempest F.6, NX247, H, No 39 squadron RAF, Khartoum AB, Sudan, 1949.



Nebeská  
Sky



Tmavá zelená  
Dark Green

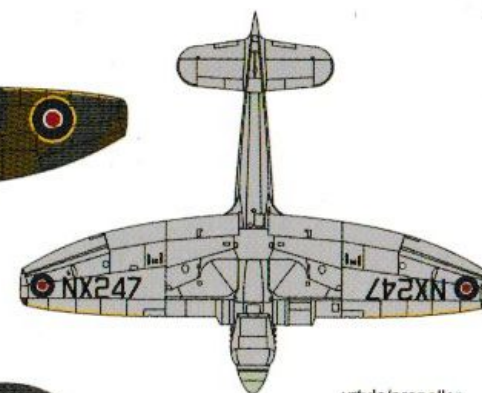

vtule/propeller



2



Hawker Tempest F.6, NX126, GN-A, 249. perut' RAF, základna Habbanya, Irák, 1947.  
Hawker Tempest F.6, NX126, GN-A, No 249 squadron RAF, Habbaniya AB, Iraq, 1947.



Červená  
Red



Žlutá  
Yellow

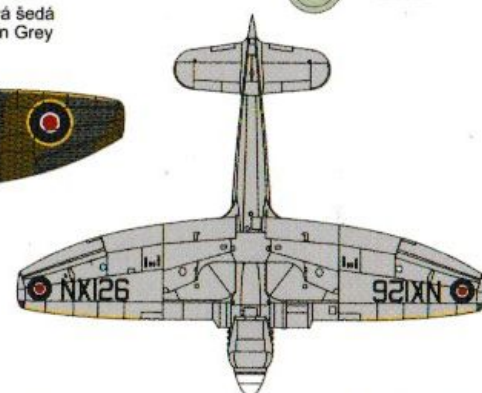

vtule/propeller



3

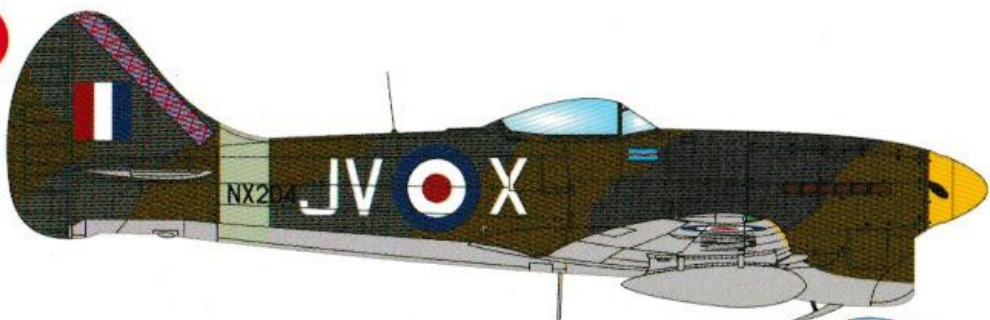

Hawker Tempest F.6, NX204, JV-X, 6. perut' RAF, základna Deversoir, Egypt, 1949.  
Hawker Tempest F.6, NX204, JV-X, No 6 squadron RAF, Deversoir AB, Egypt, 1949.



Černá  
Black



Výfuky  
Exhausts

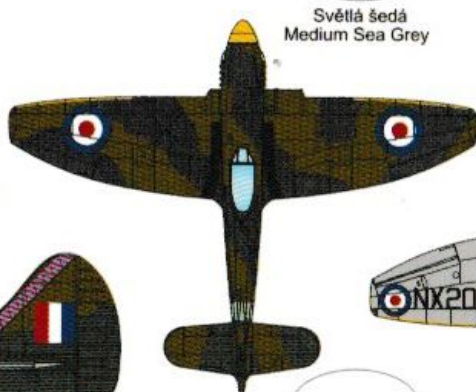

vtule/propeller



Bílá  
White