

FRENCH LIGHT TANK

AMX-13/90

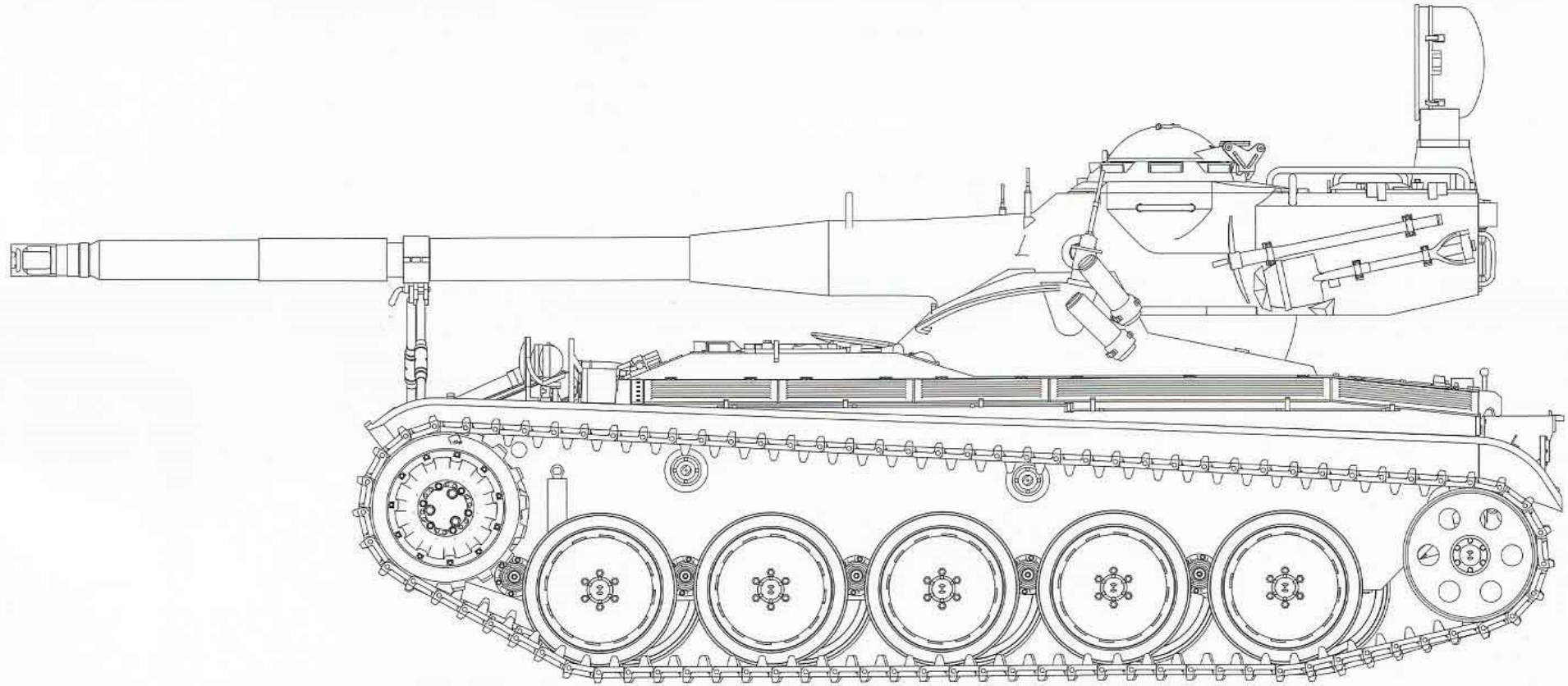

Adopted by the French Army to replace their U.S. supplied light tanks, the AMX-13 was designed in 1950 by Atelier de Construction D'Issy-les-Moulineux, and produced by Atelier de Construction Roanne until 1987 with some 7,700 examples having been produced. The most striking feature of the AMX-13 tank is its oscillating GIAT turret. Rather than the gun pivoting on trunnions within the turret, a 'sub-turret' (and the gun) elevates within the rotating turret. This design eliminates the normally bulky mantlet/gun shield on conventional designs, and allows a lower overall height. Built into the turret bustle is an automatic loader fed by 2 revolving magazines holding 6 rounds each of ready ammunition, with a rate of fire of 10 rounds per minute. Although this feature reduces the number of crew required to operate the tank, and certainly provides a formidable burst of firepower in an initial engagement, it exposes the crew during the time consuming process of reloading through the roof of the turret. With a combat weight of 14.8 tons and a crew of 3, the AMX-13/90 is powered by 150hp air cooled SOFAM 4G5dE2 4 cylinder, liquid cooled gasoline engine with a syncromesh transmission providing 5 forward and 1 reverse speeds reaching a road speed of 60km/h.

The AMX-13/90 is armed with the D919B 90mm gun with 31 rounds and either a 7.5 or 7.62mm AAT-52 Tak coaxial machine gun with 3,600 rounds (with optional second AAT-52 on roof ring). This particular tank is powered by 150hp air cooled SOFAM 4G5dE2 4 cylinder engine. The tank is constructed of welded steel armor plates ranging from 20mm to 40mm thick, with the engine located in the front.

Of the 7,700 produced, 3,400 AMX-13's were exported broadly, and have seen combat from Africa to Central America to the Middle East to the Indian Subcontinent. Operators include Algeria, Argentina, Austria, Belgium, Cambodia, Chile, Cyprus, Dominican Republic, Djibouti, Ecuador, Egypt, El Salvador, France, Guatemala, India, Indonesia, Israel, Ivory Coast, Kuwait, Lebanon, Morocco, Nepal, Netherlands, Peru, Singapore, Switzerland, Tunisia, and Venezuela. The French Army retired their fleet of AMX-13's in the 1970's, but they remain in service with many nations today.

READ BEFORE ASSEMBLY

CAUTION

- Read carefully and fully understand the instructions before commencing assembly. A supervising adult should also read the instructions if a child assembles the model.
- When assembling this kit, tools including knives used. Extra care should be taken to avoid personal injury.
- Keep out of reach of small children. Children must not be allowed to suck any part, or pull vinyl bag over their heads.



Optional



Remove



Do Not Cement



Drill



Instant Glue
for Metal



Be Careful

PAINTS REQUIRED

Color info and profiles by Mig Jimenez

A.MIG 033

Rubber &
Tires

A.MIG 036

Old Wood

A.MIG 042

Old Rust

A.MIG 105

Washable Dust

A.MIG 045

Gun Metal

A.MIG 071

Khaki

A.MIG 093

Crystal Red

A.MIG 035

Dark Tracks

A.MIG 057

Yellow Grey

A.MIG 081

US Olive Drob

APPLYING DECALS

1. Clean the model surface with a wet cloth.
2. Cut out each decal design from sheet, and dip it in tepid water for 15~20 sec.
3. Hold the backing sheet edge and slide decal onto the model.
4. Move decal into position by wetting decal with finger.
5. Press decal gently down with a soft cloth until excess water and air bubbles are gone.

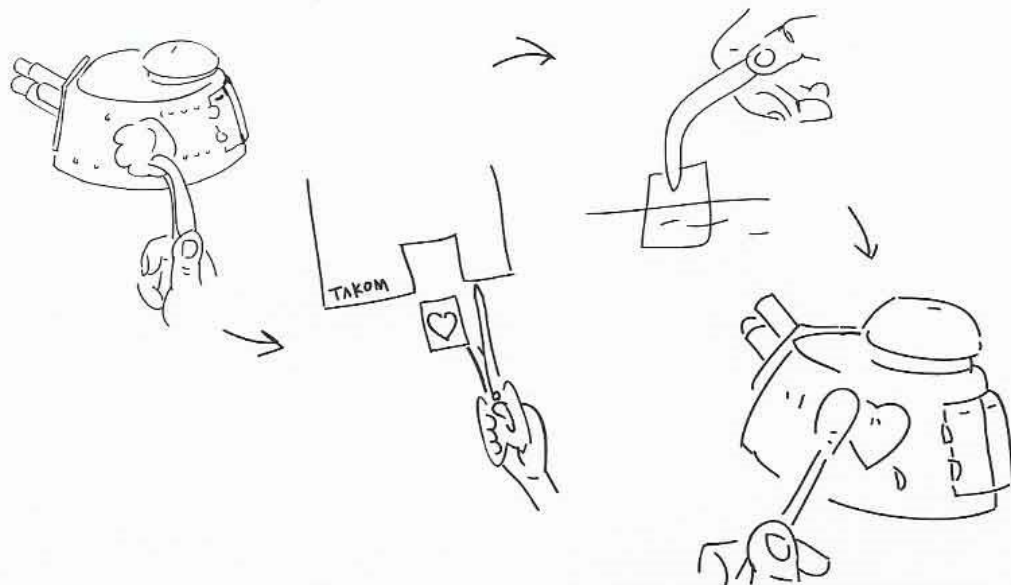

REMOVING PE

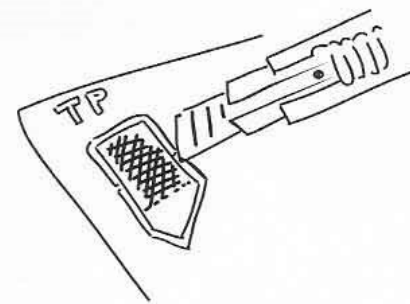

Be careful not to hurt when removing PE parts.

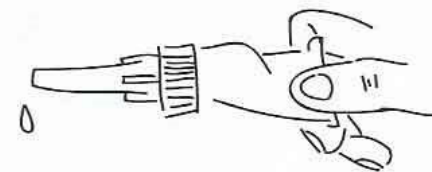

Secure using instant glue (not included).



Finish using file.

PARTS

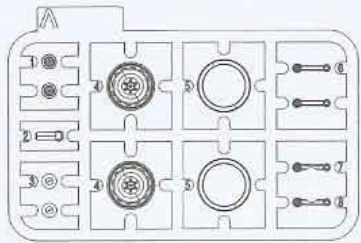

X5

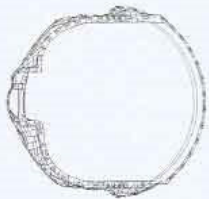
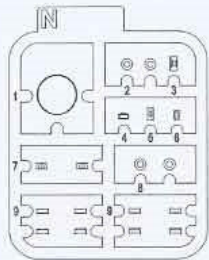

Dust Cover

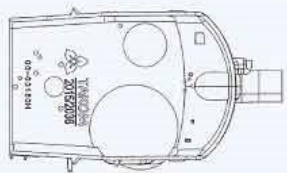

Turret

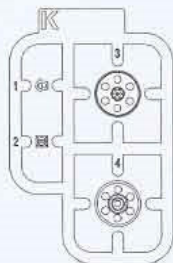
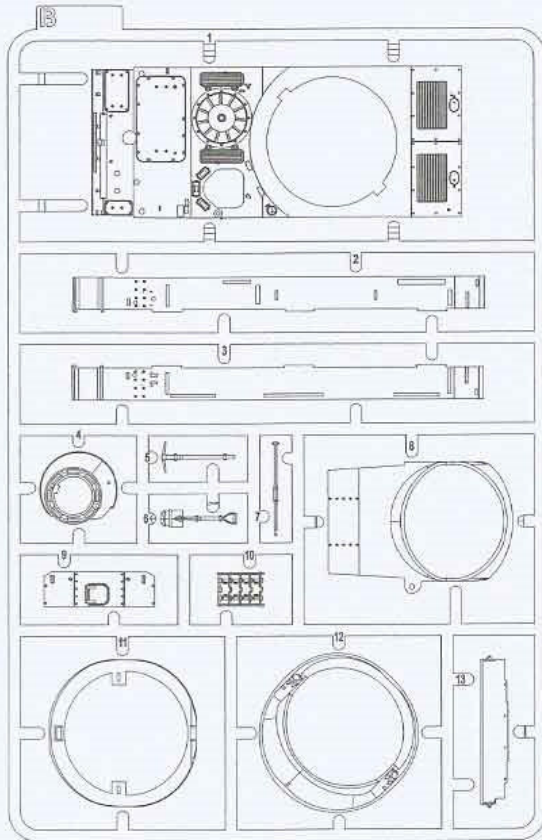

X2

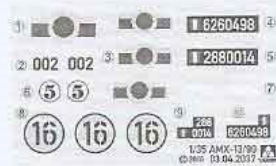

Decal

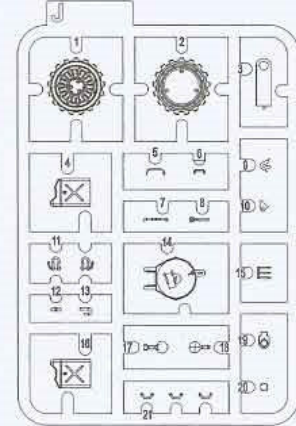
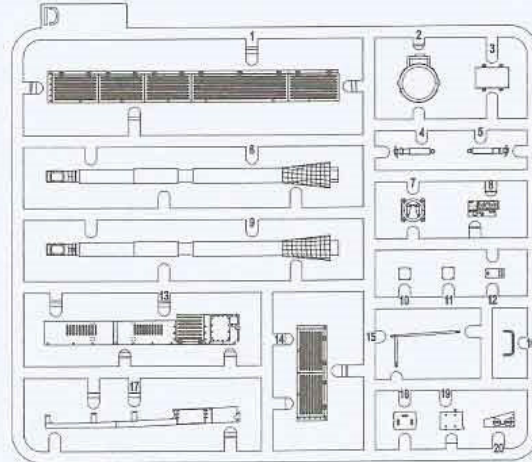

X2



Lower Hull

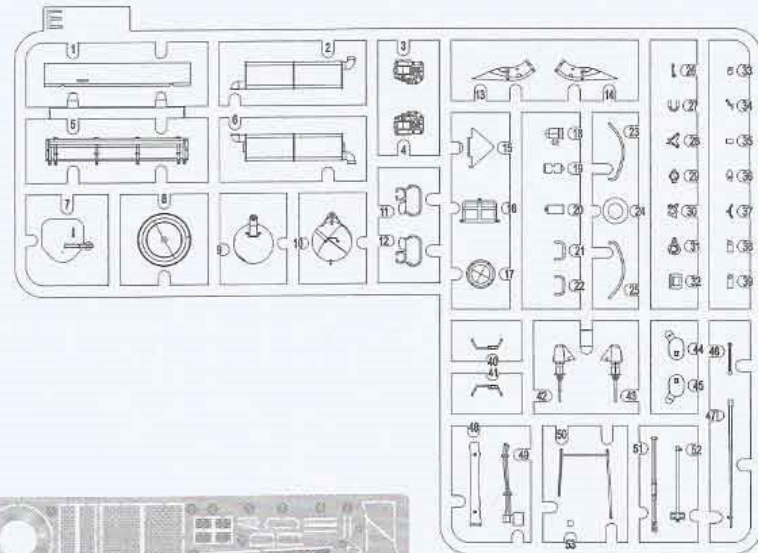

X10

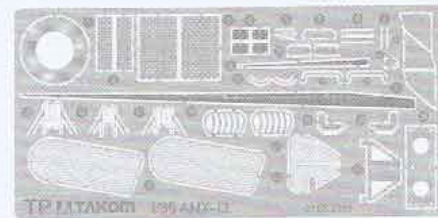

TP

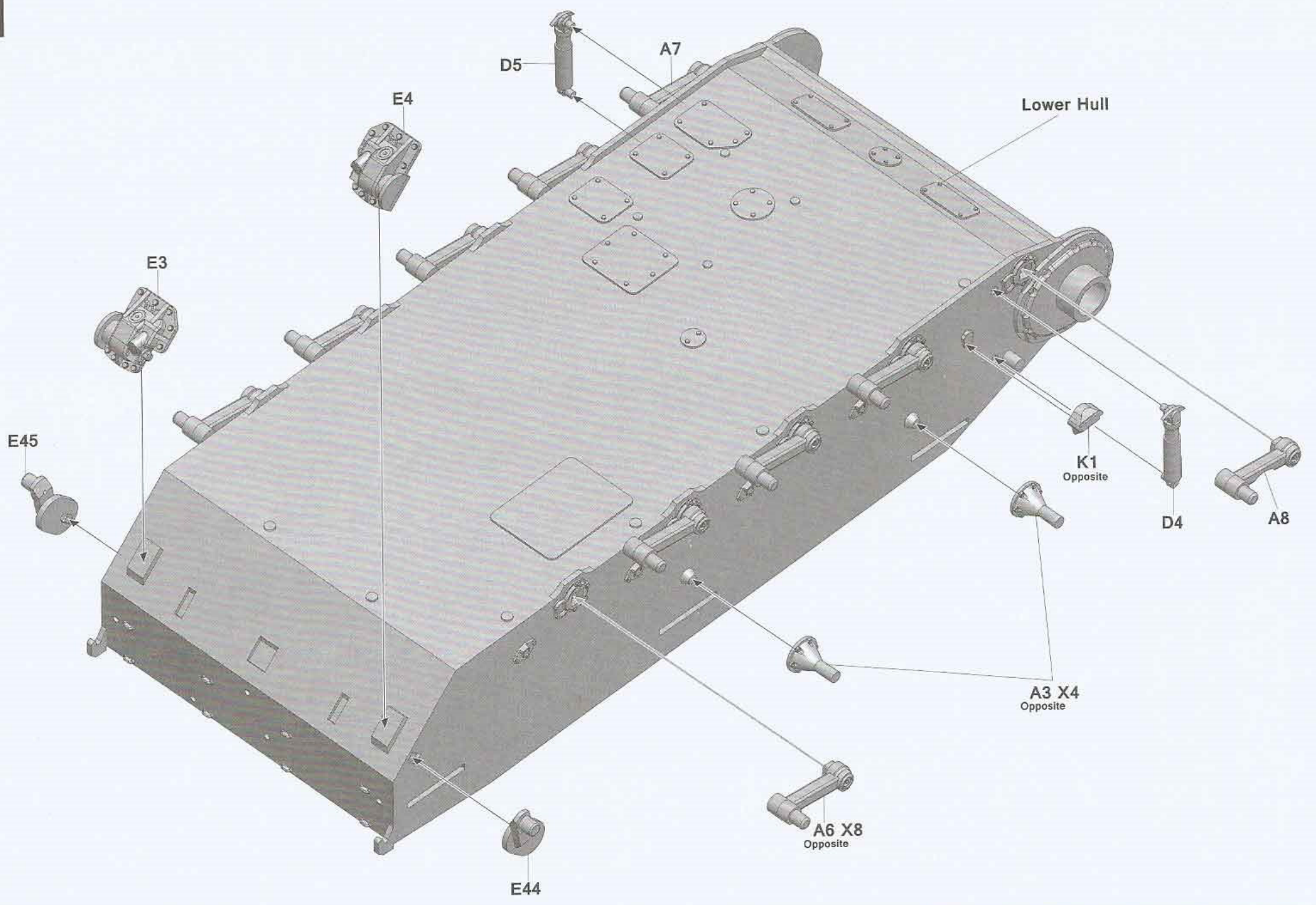

2

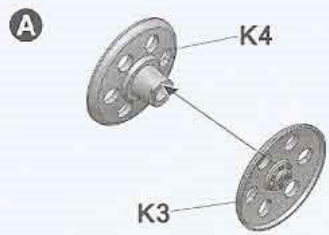

Make 2

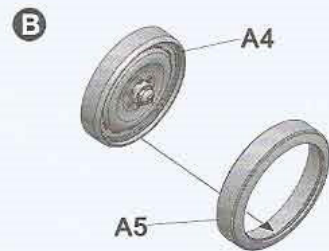

Make 10

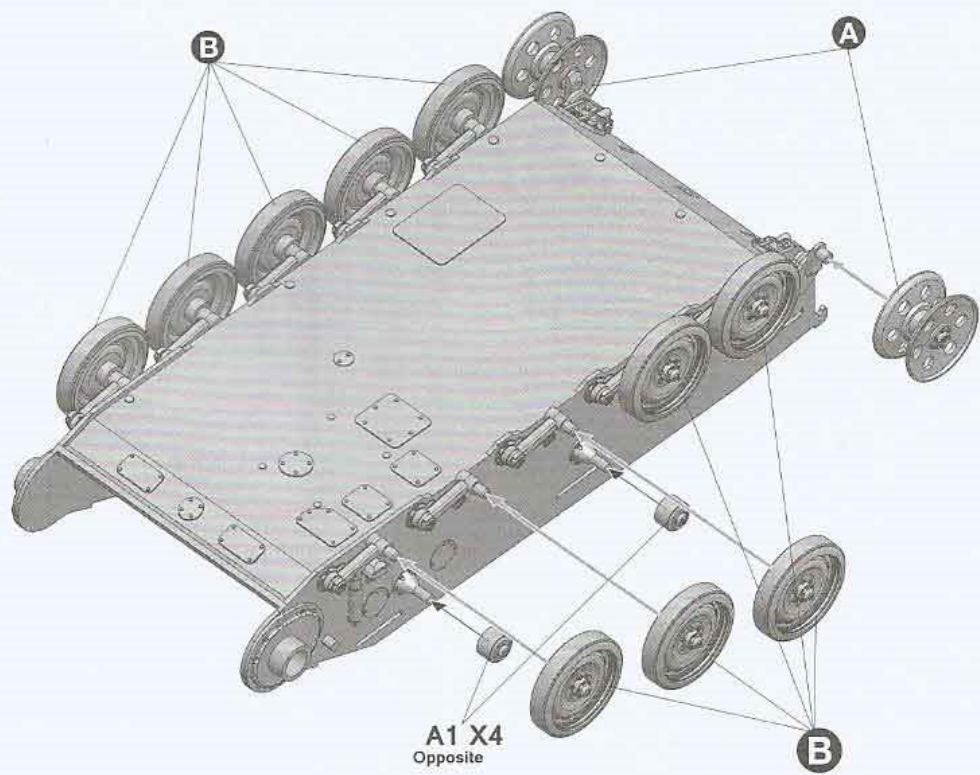

3

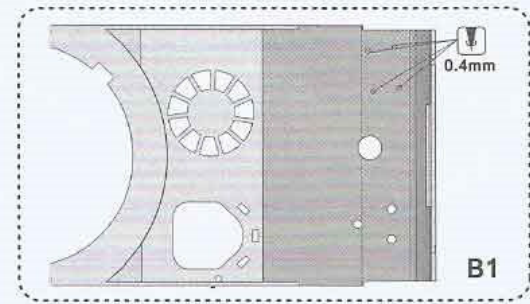
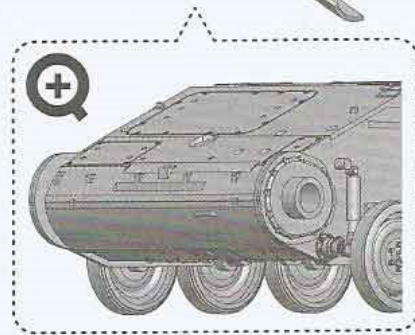
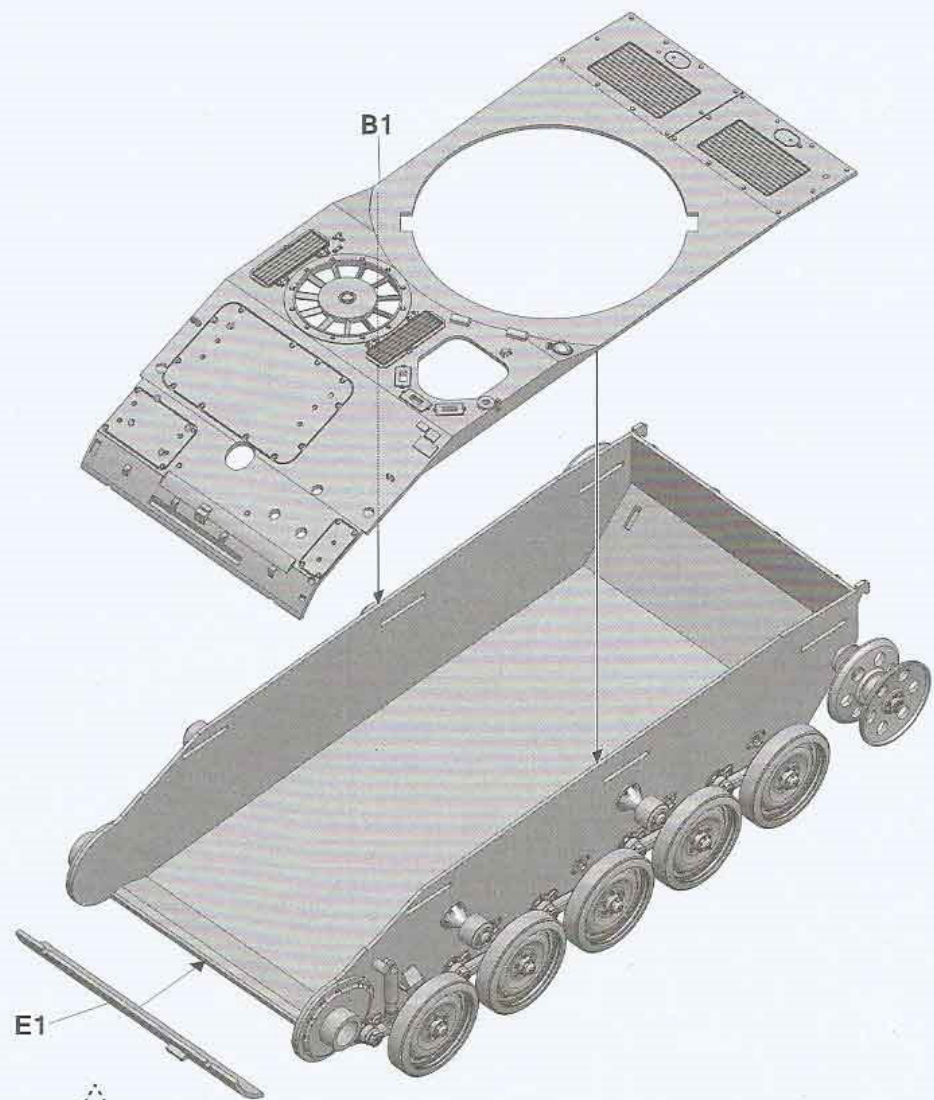

4

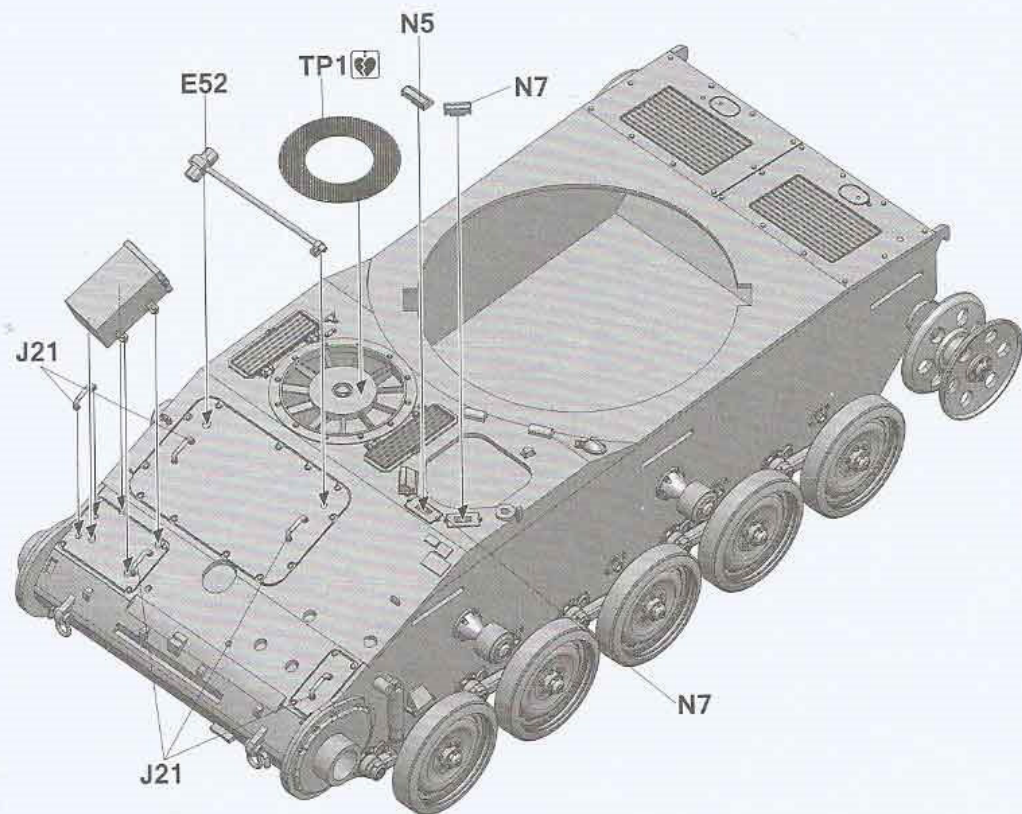
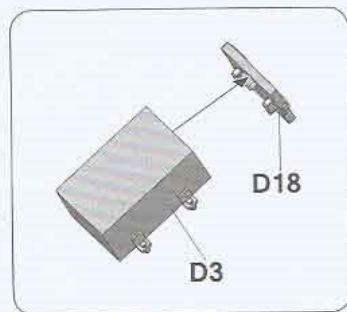

5

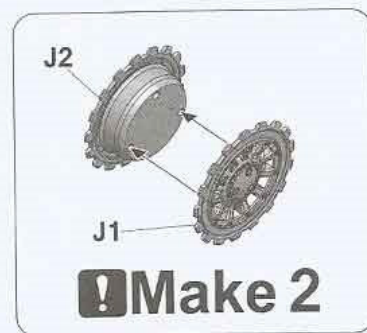
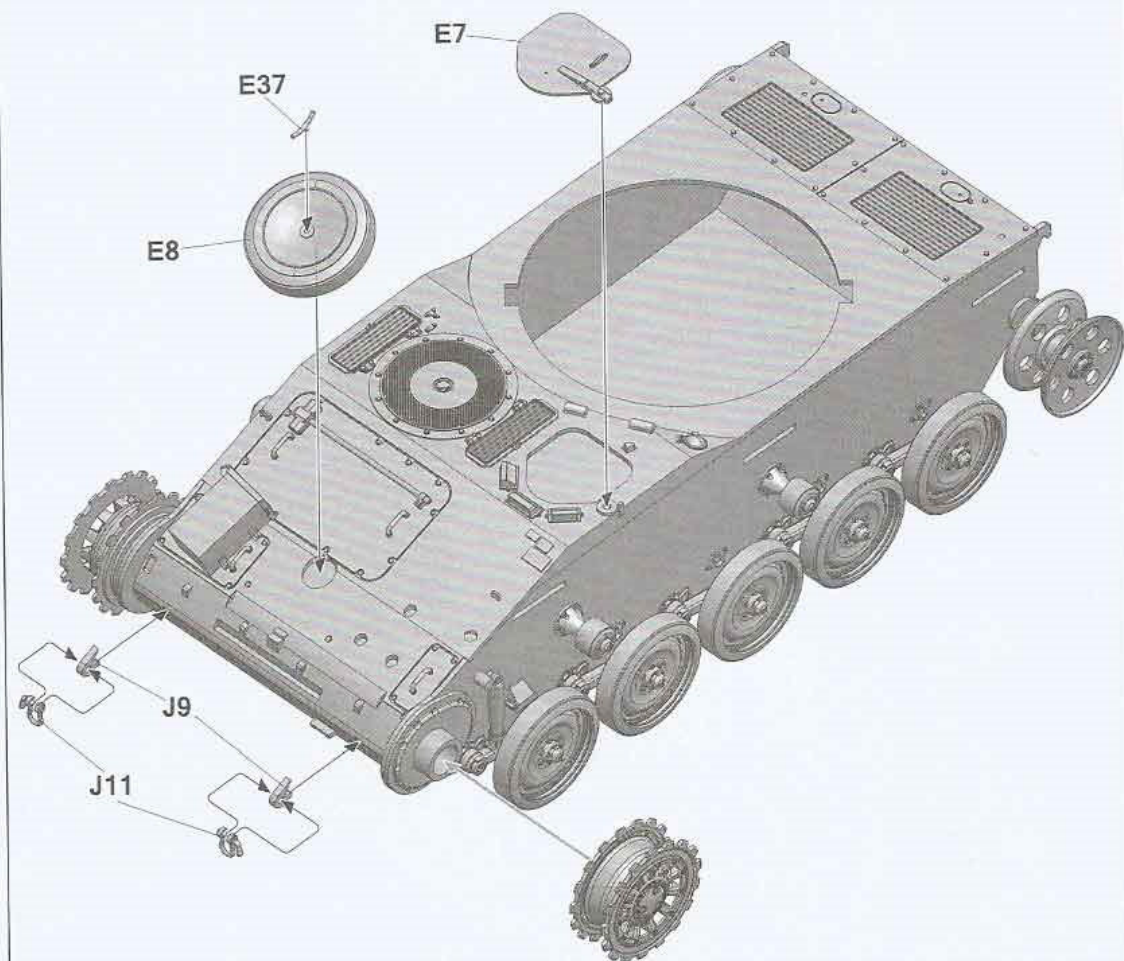

6

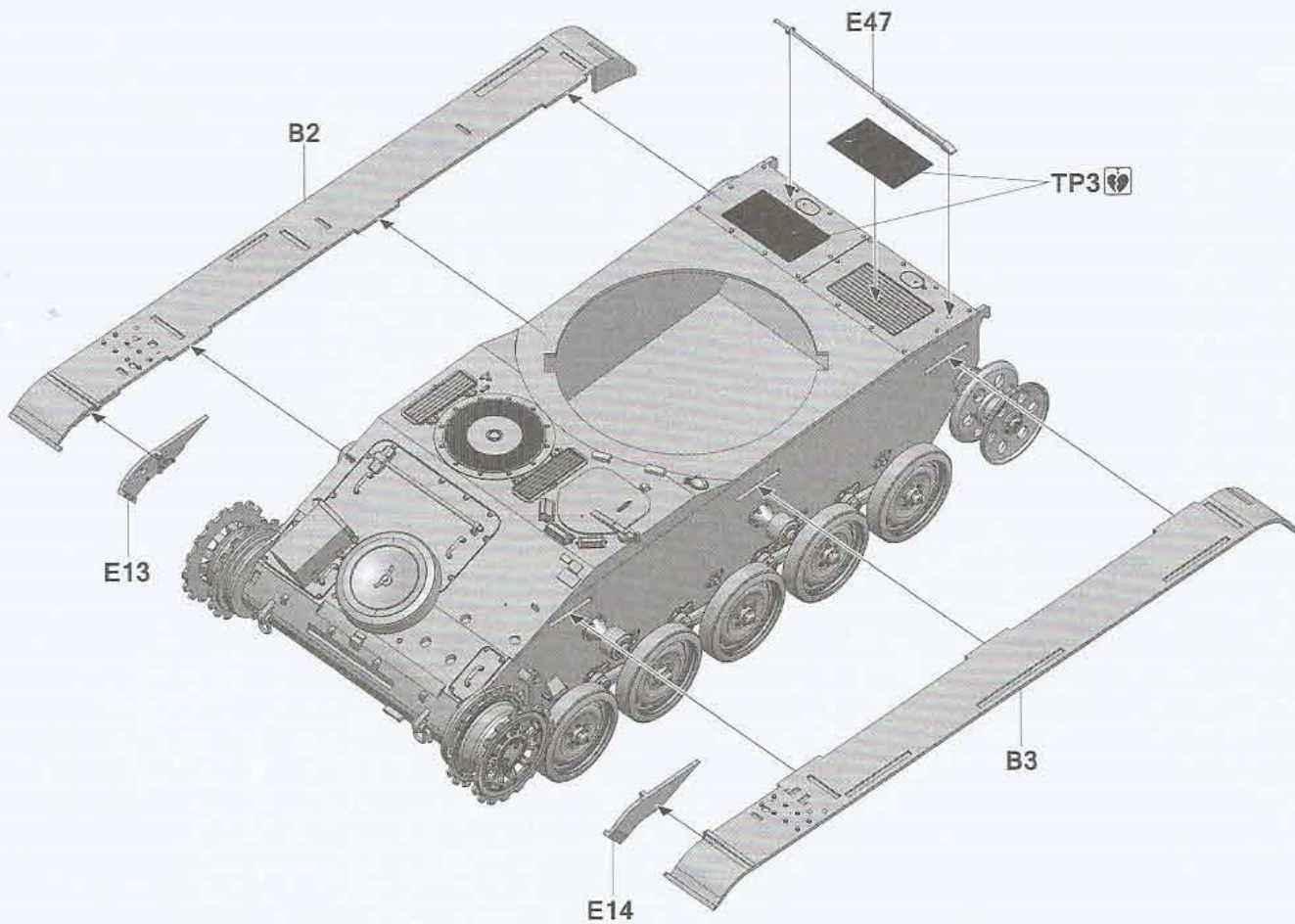
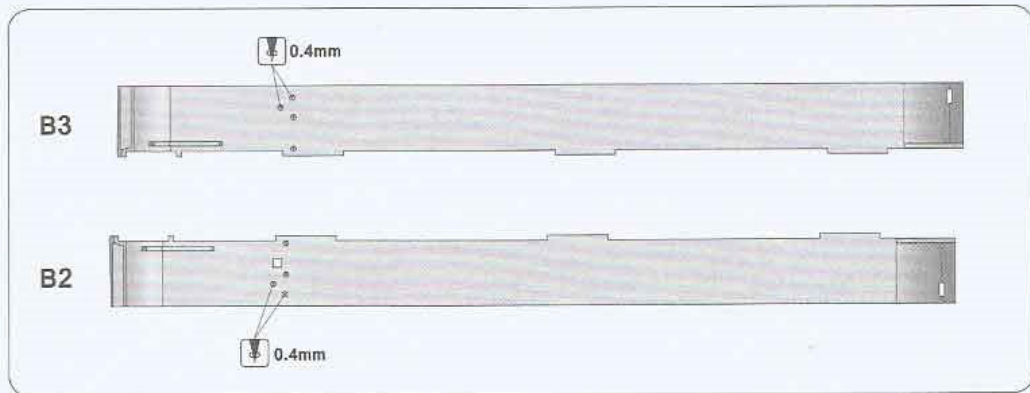

7

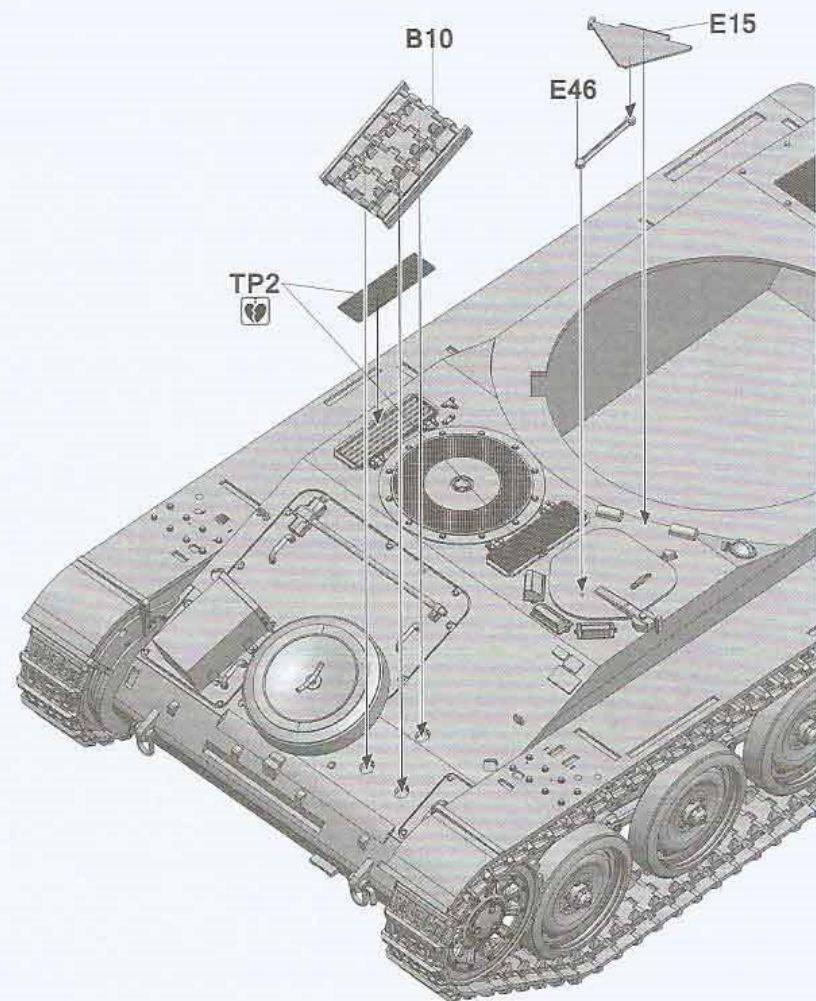
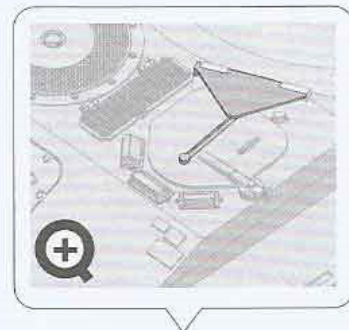
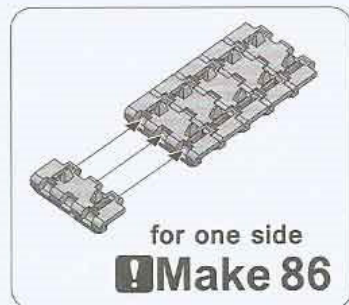

8

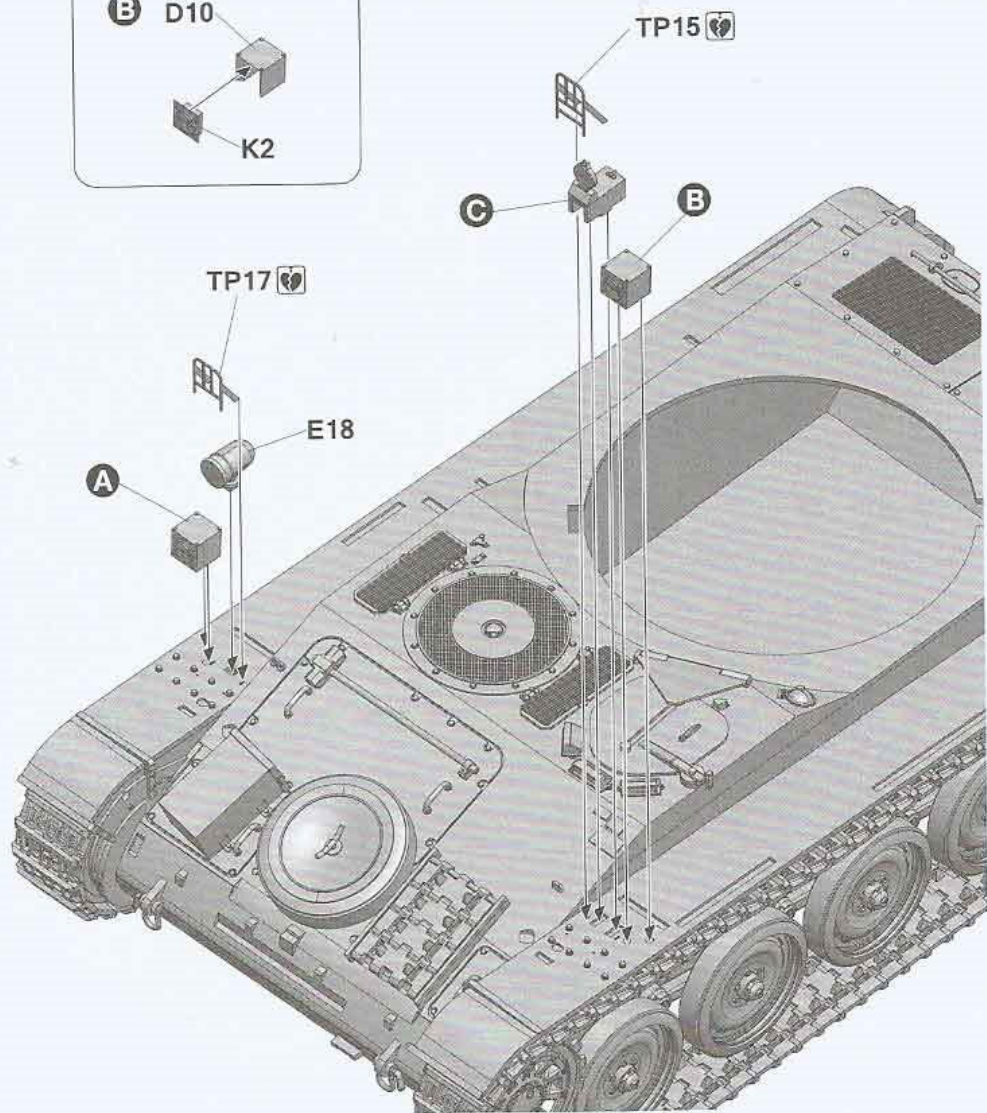
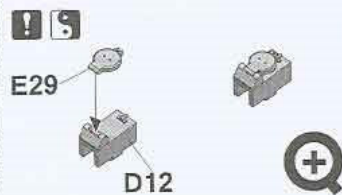
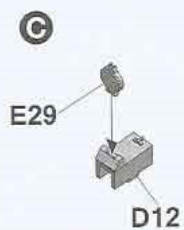
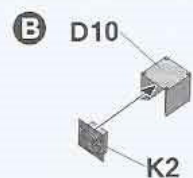
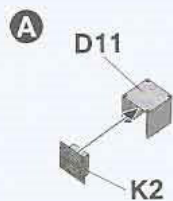

9

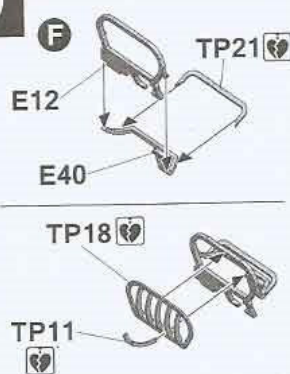

TP11

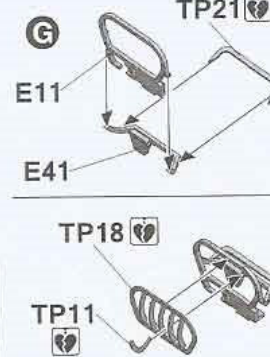
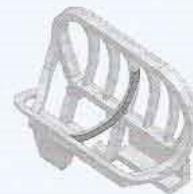

TP21

TP11

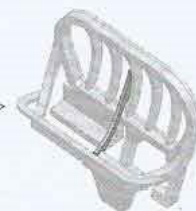

TP11

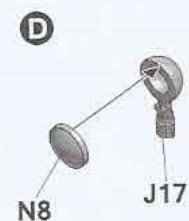
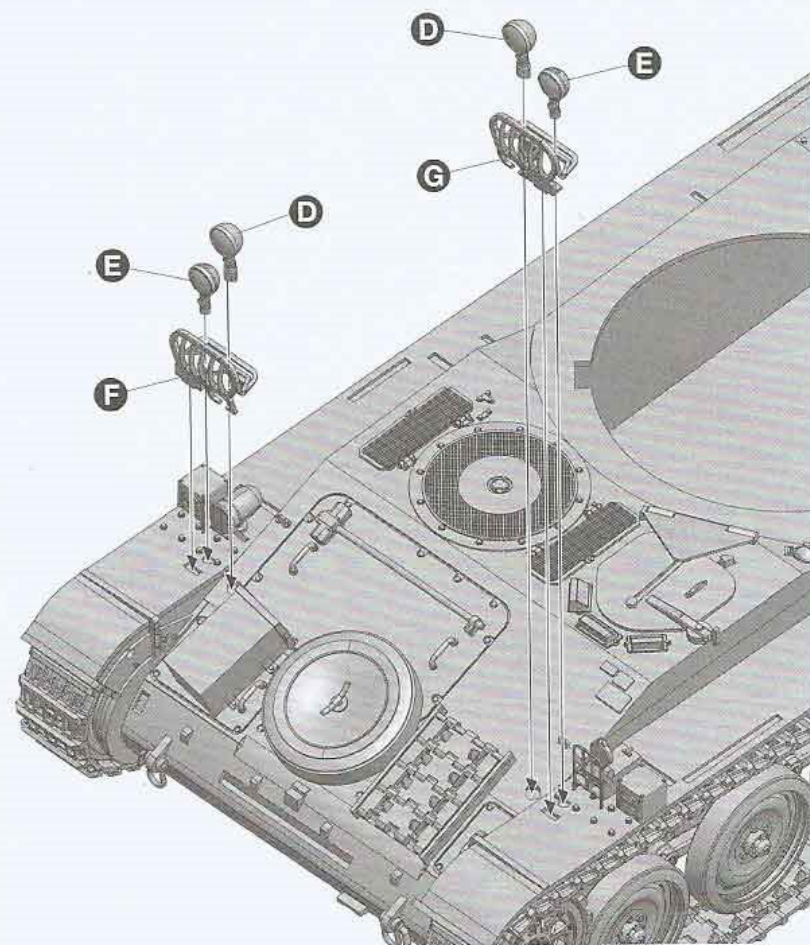
**!** Make 2**!** Make 2

10

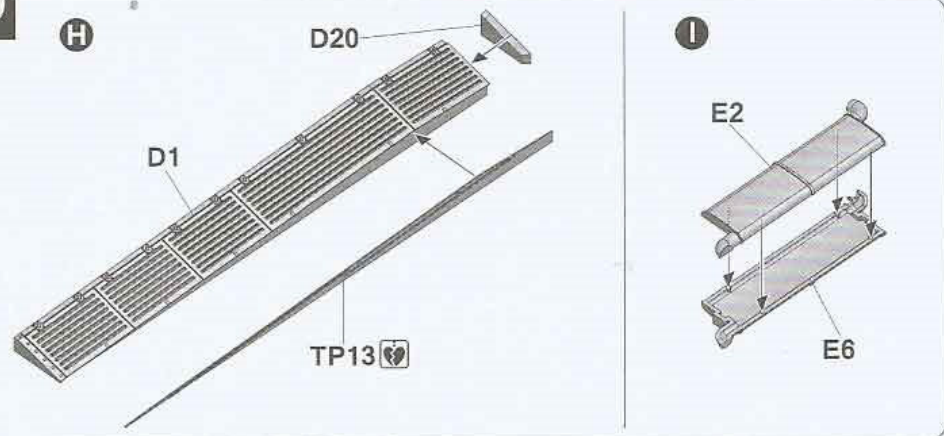

11

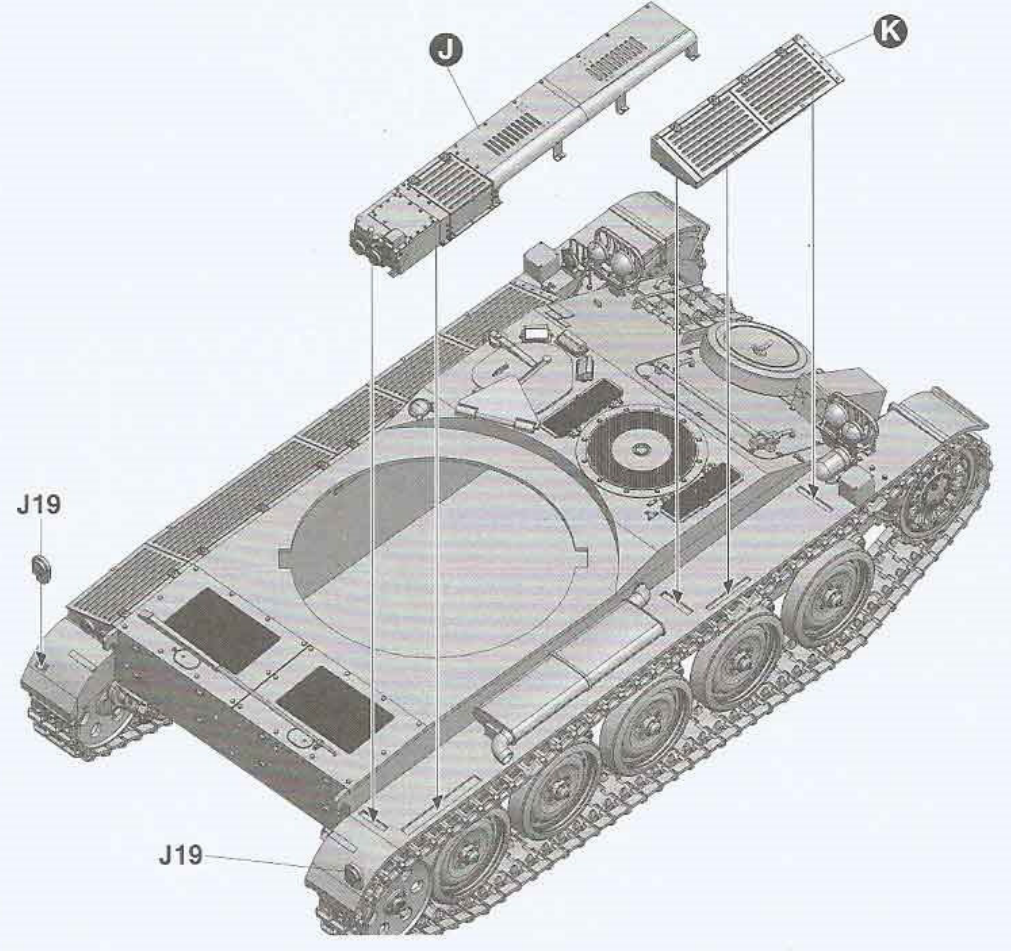
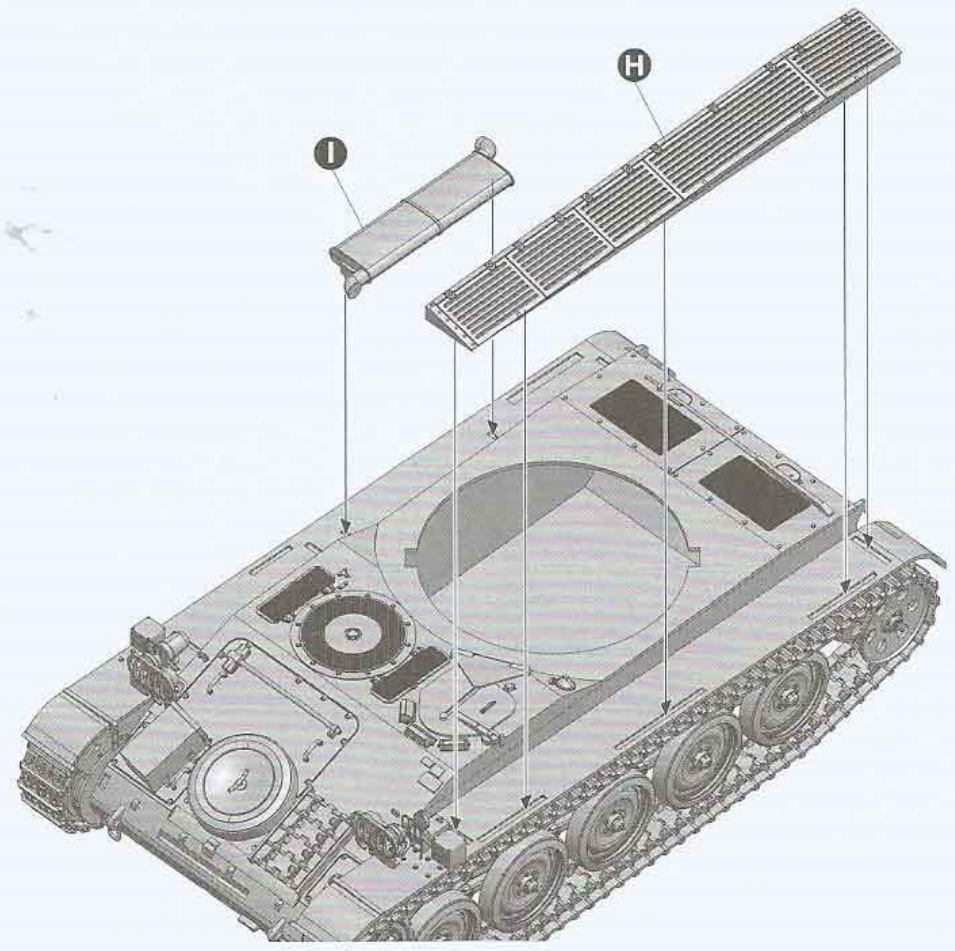
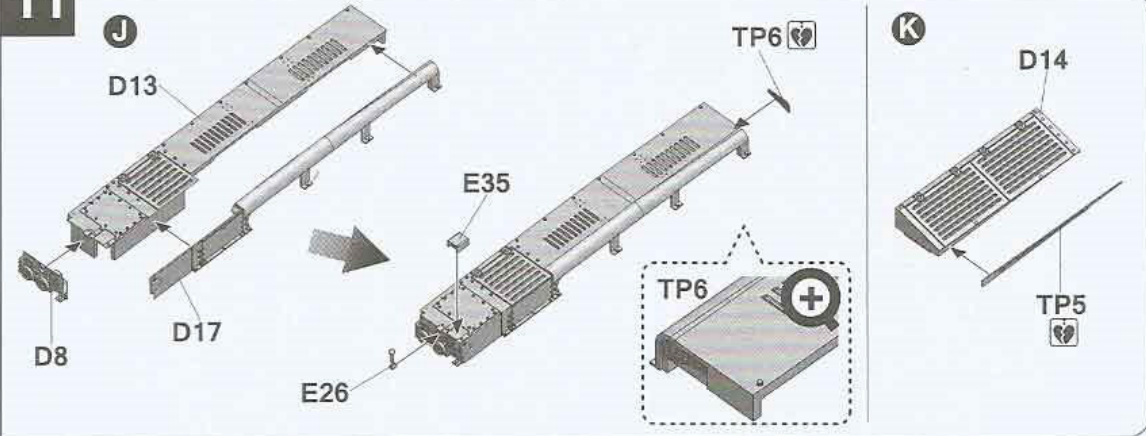

12

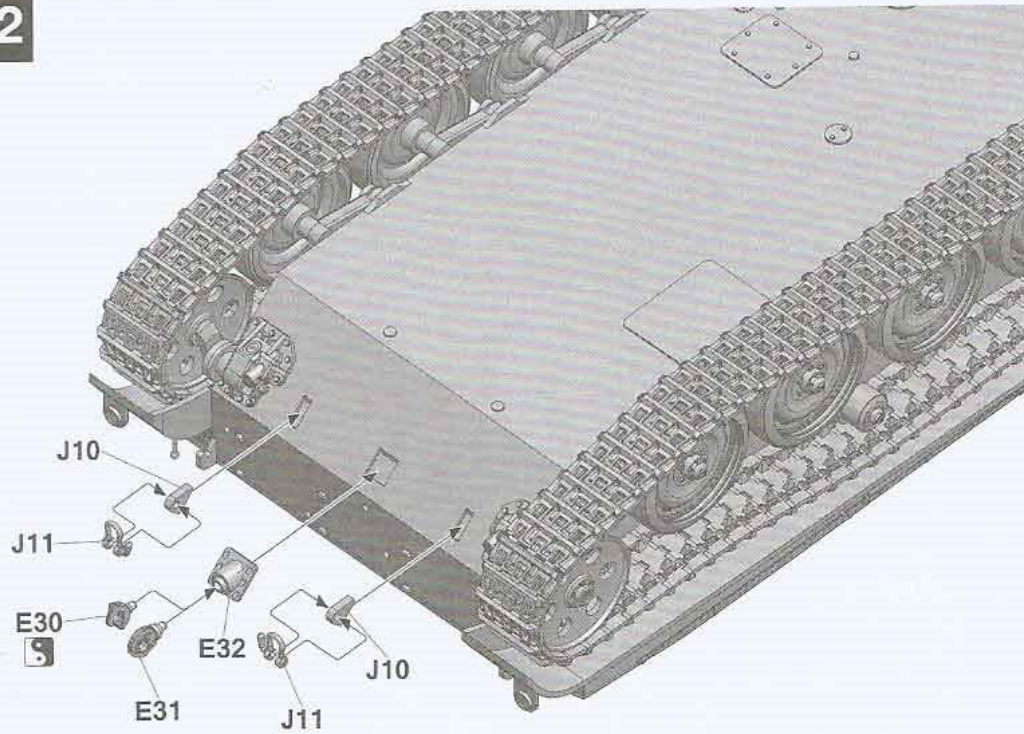

14

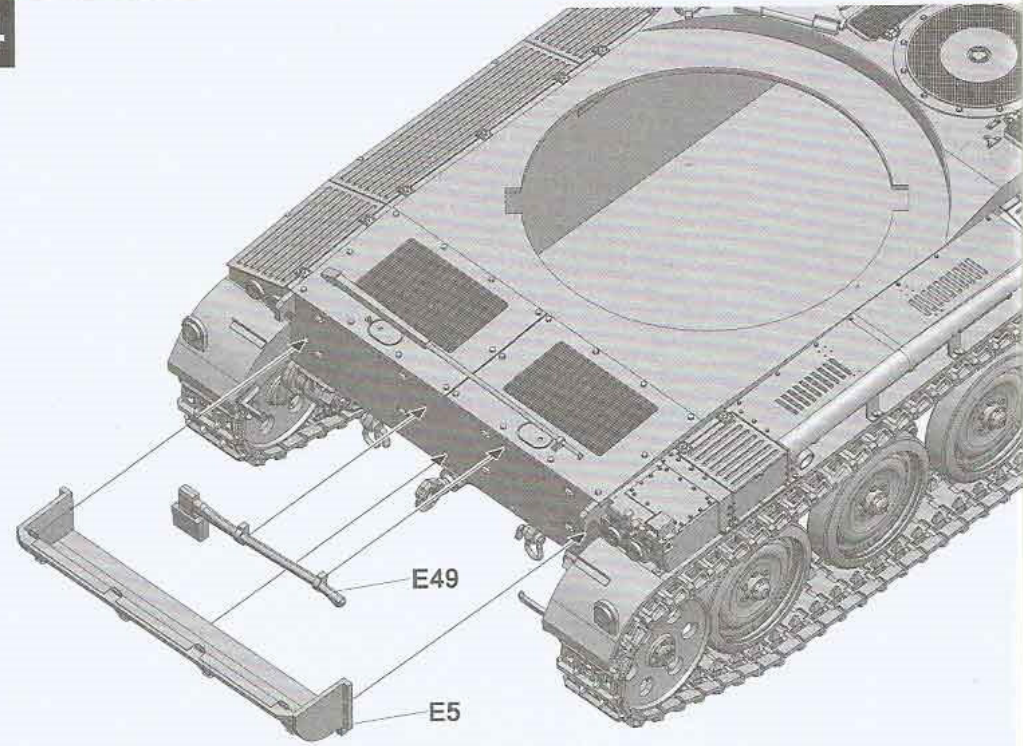

13

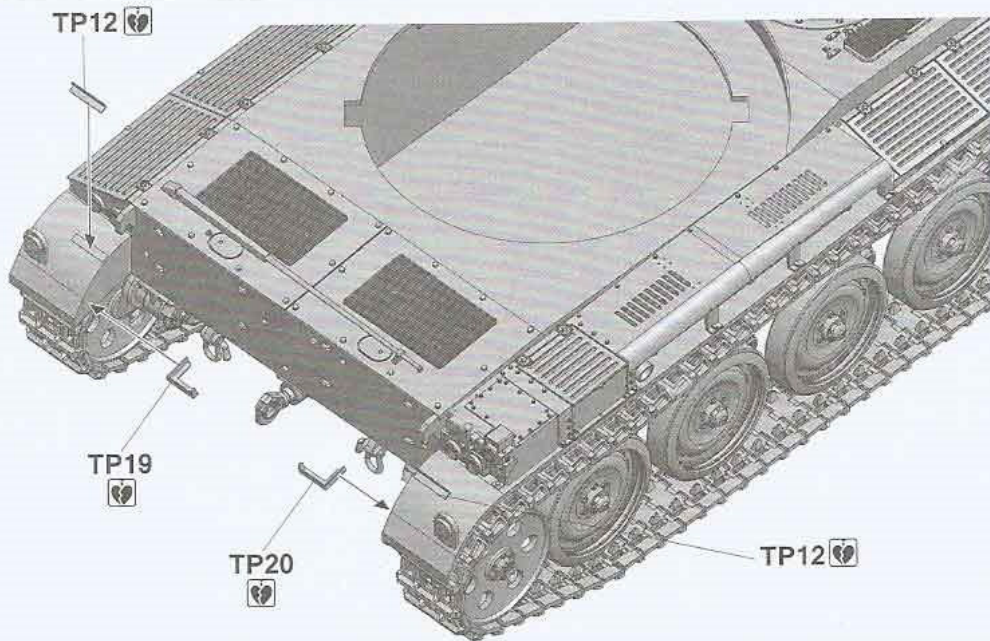

15

Turret

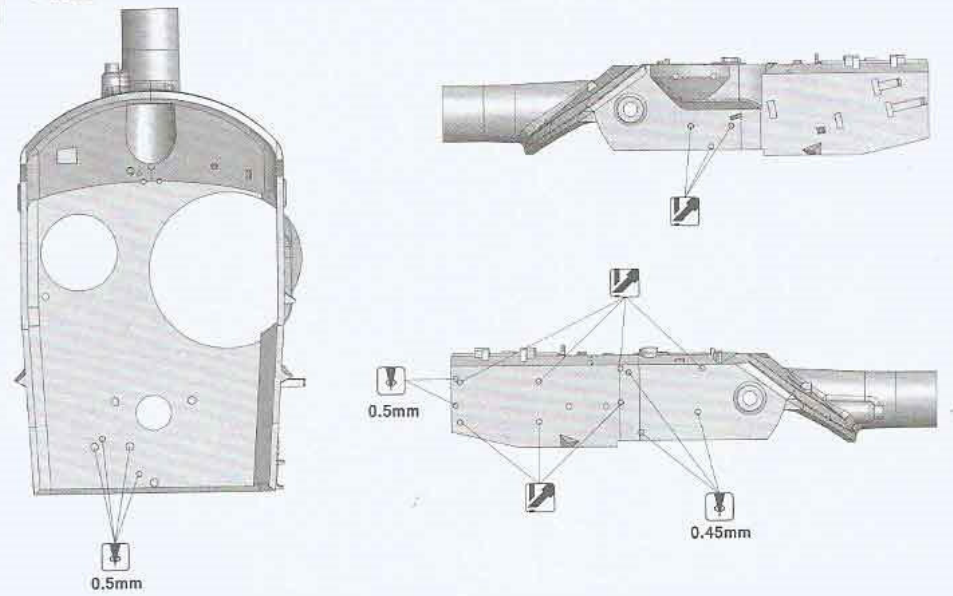

16

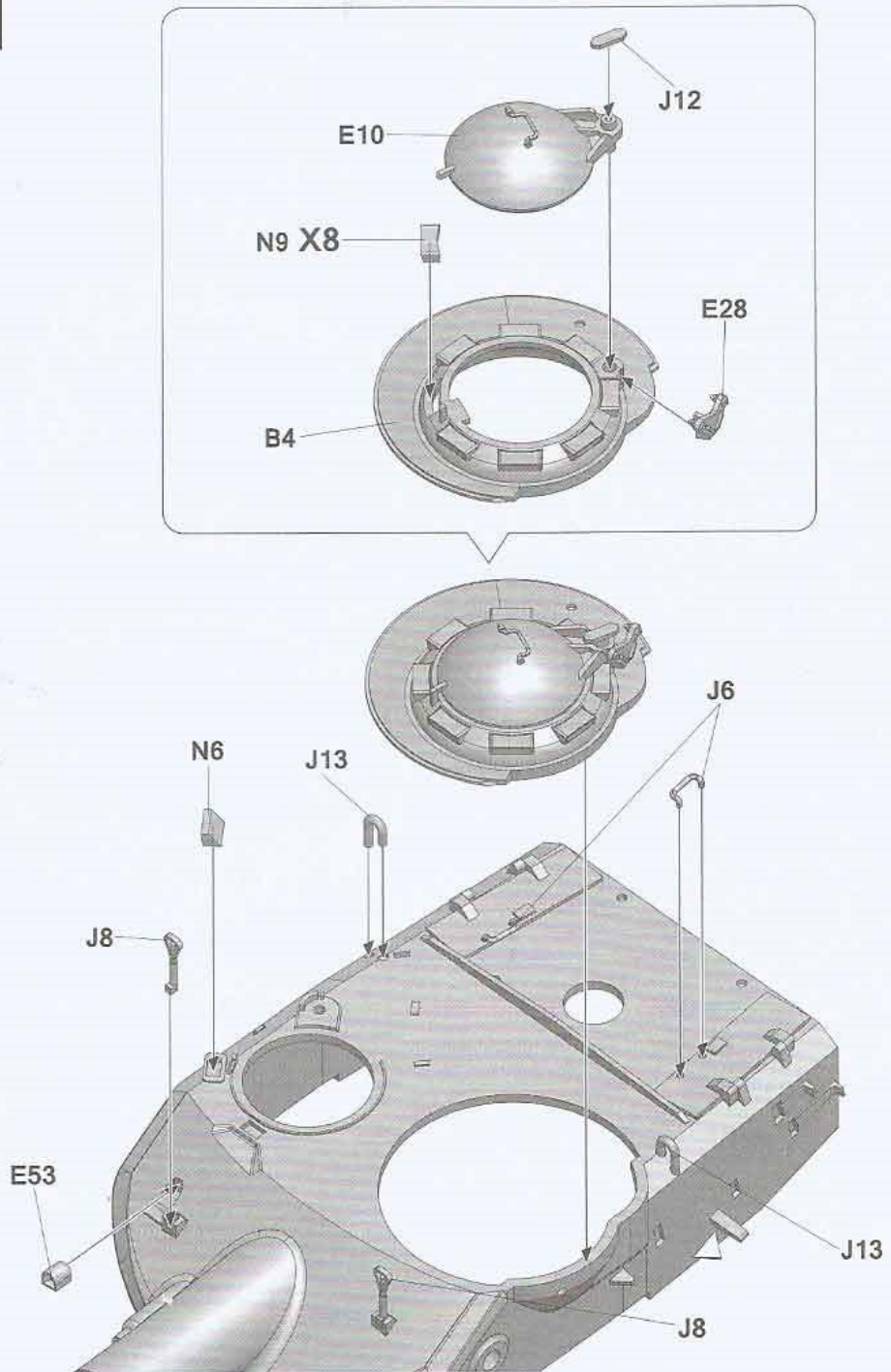

17

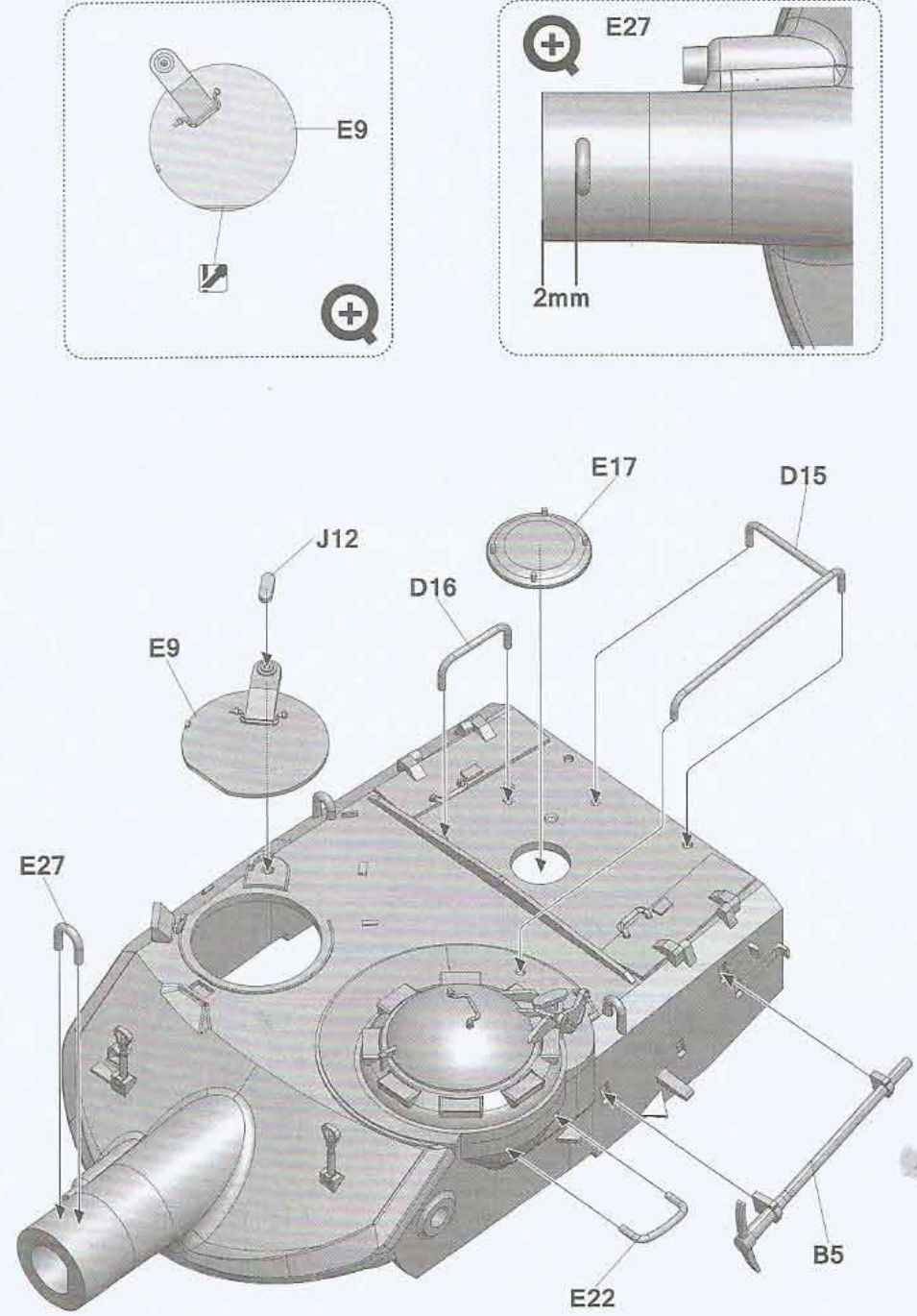

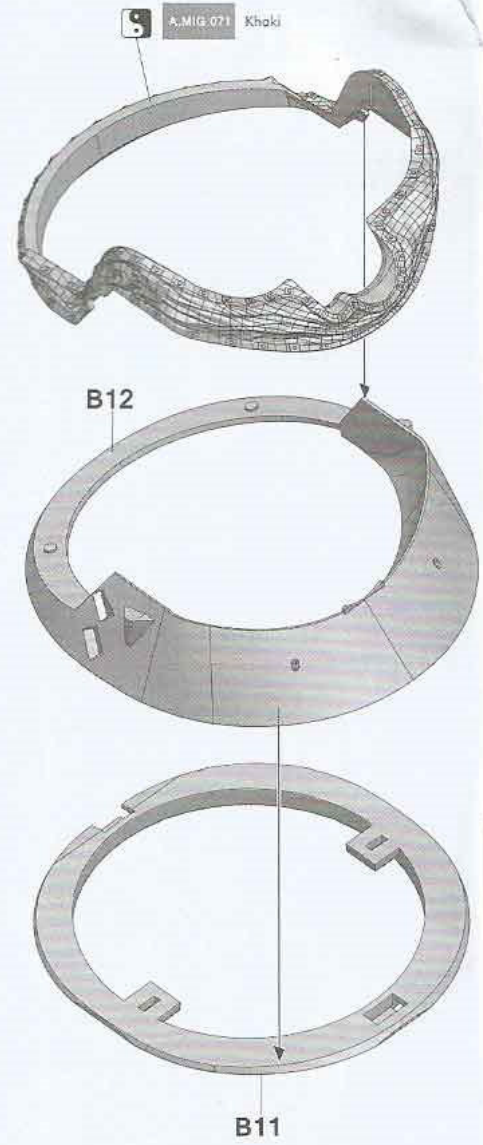
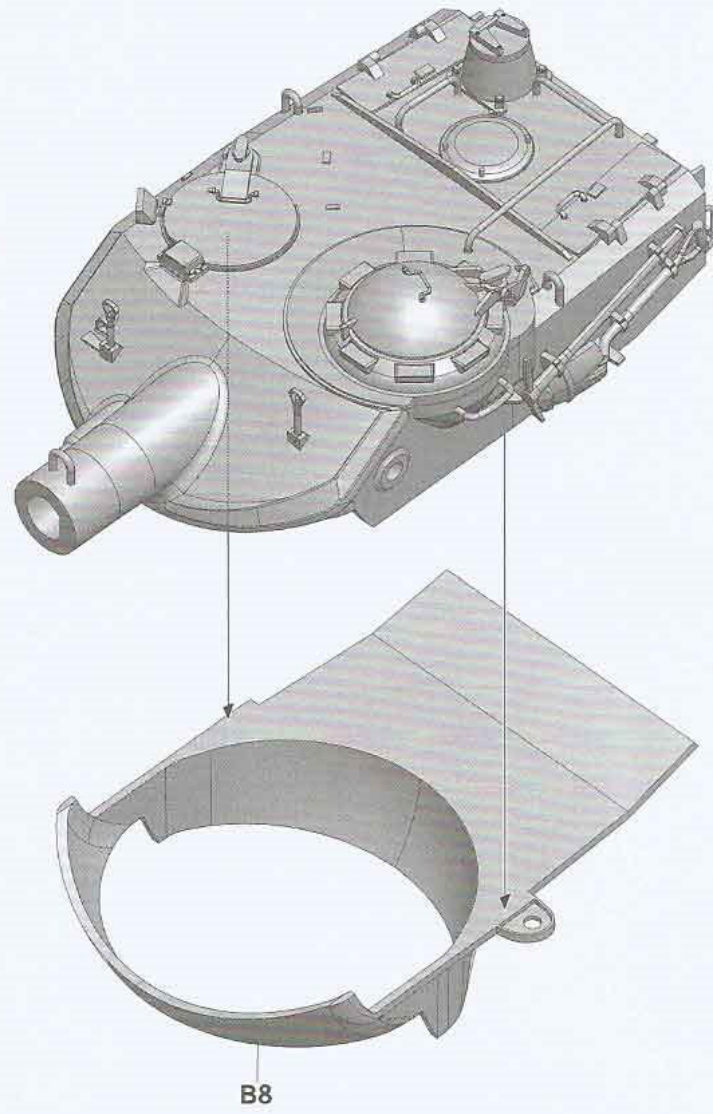
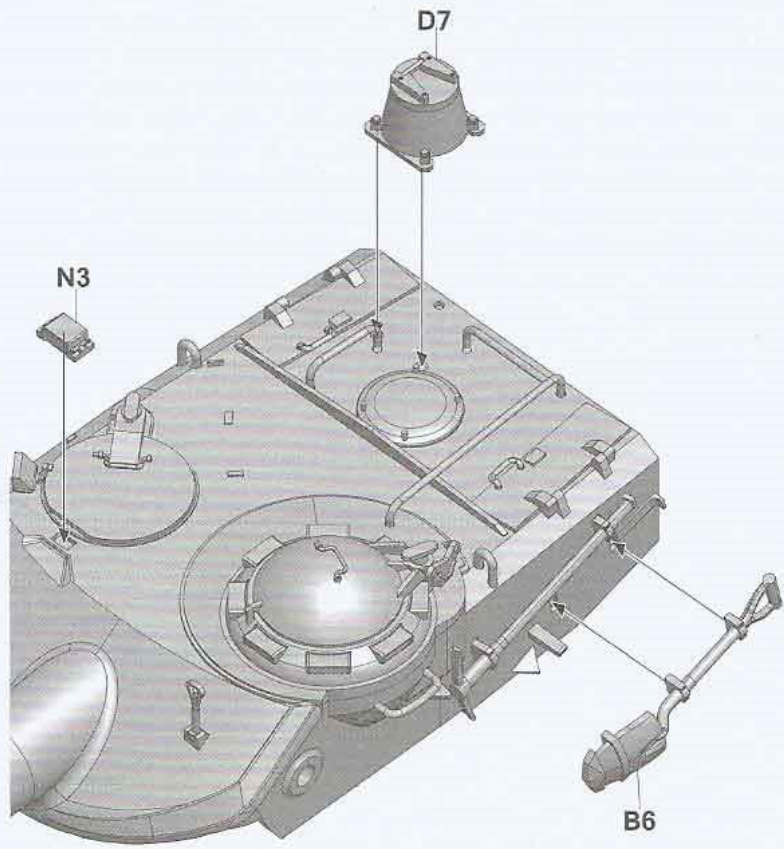

21

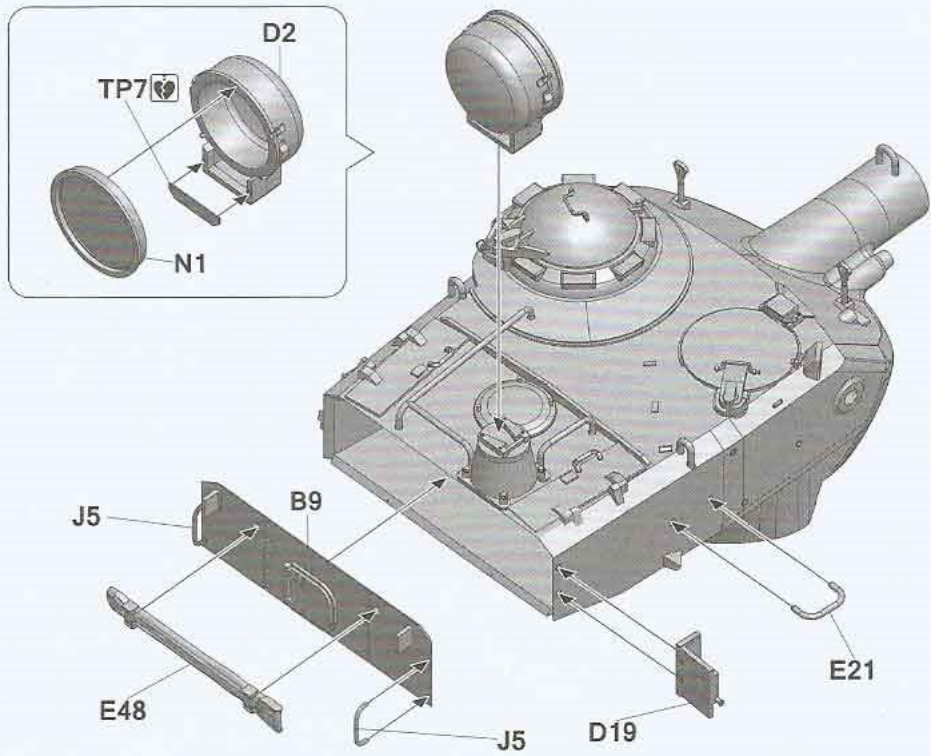

S

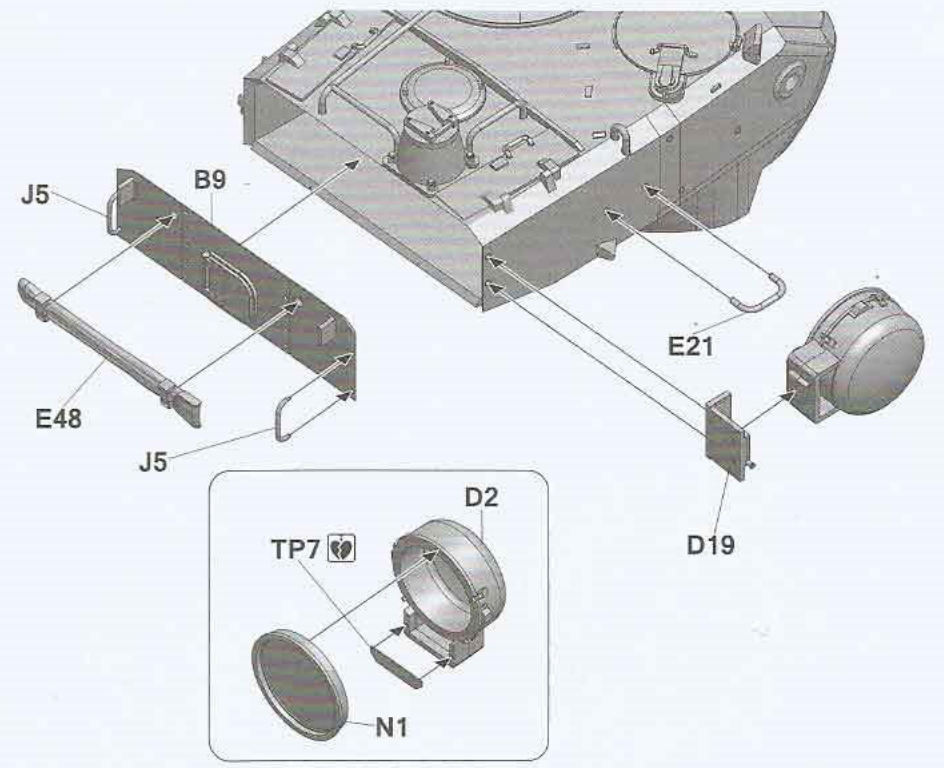

22-1

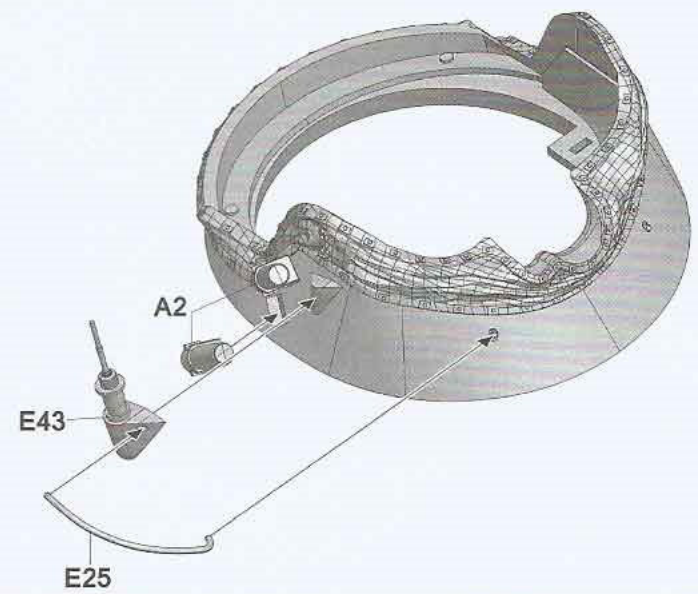

22-2 Without Dust Cover

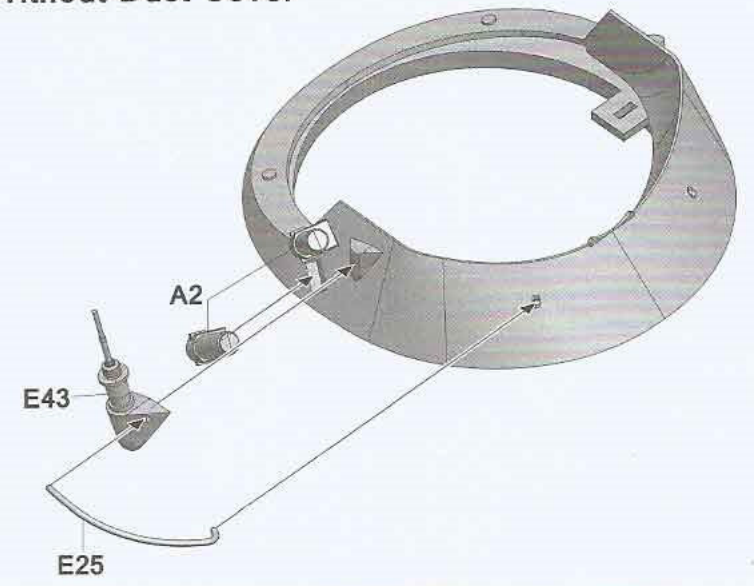

11 23-1

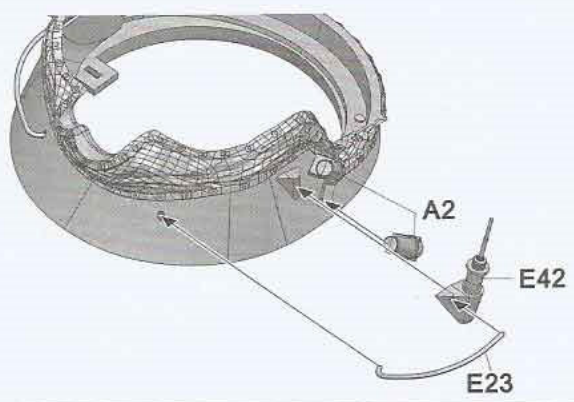

23-2

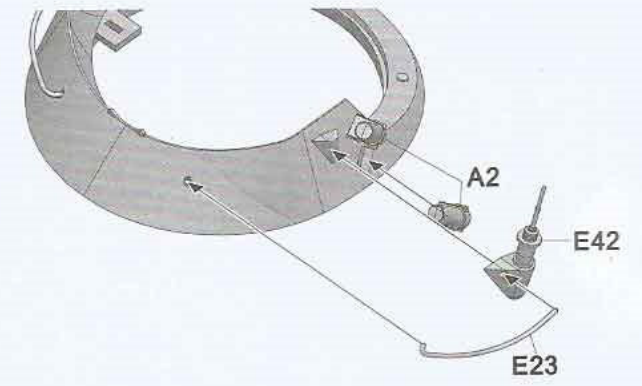

24-1

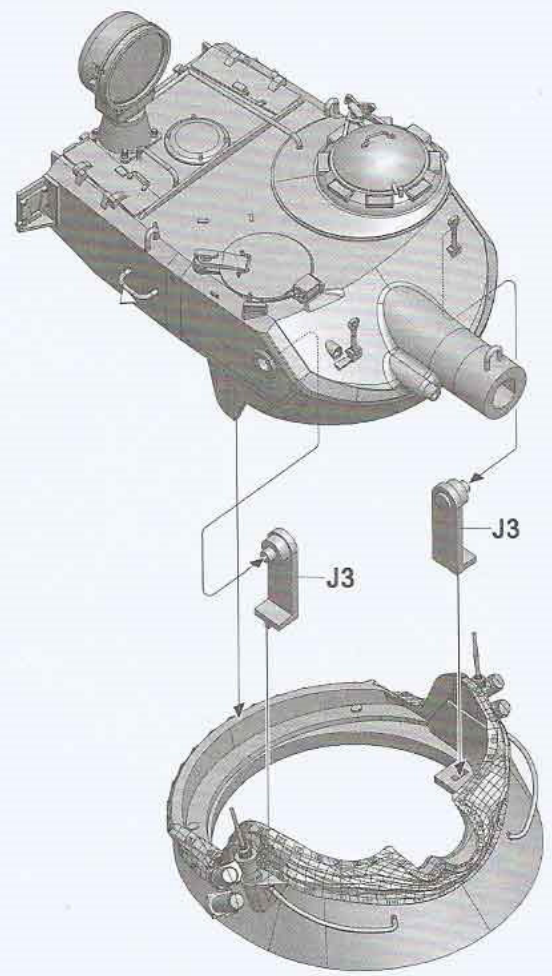

24-2

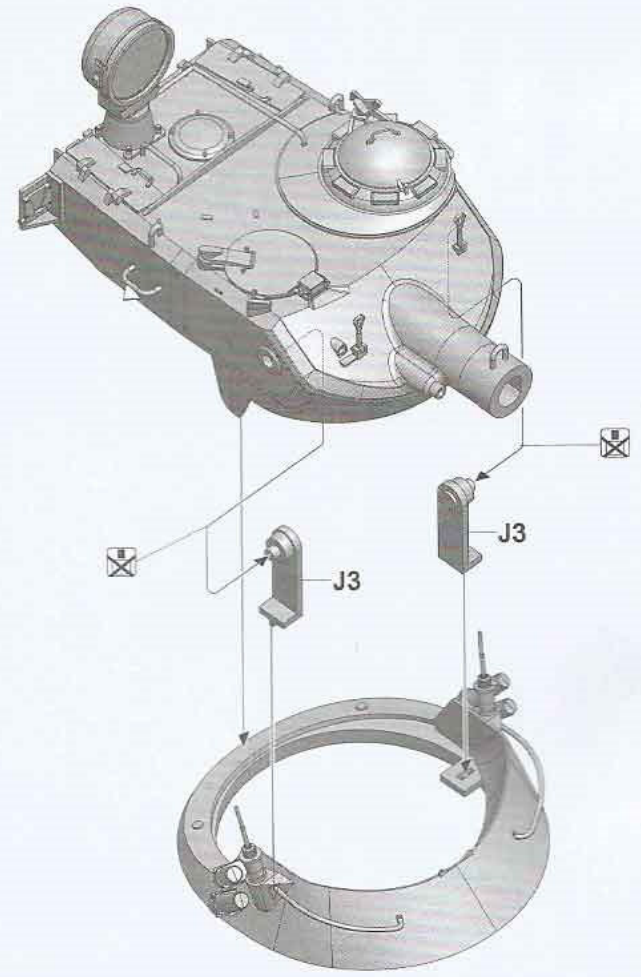

25-1

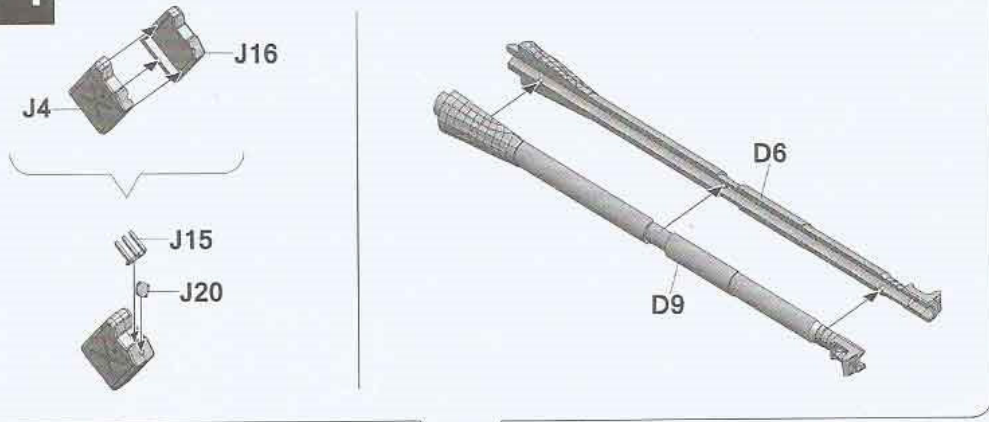

25-2

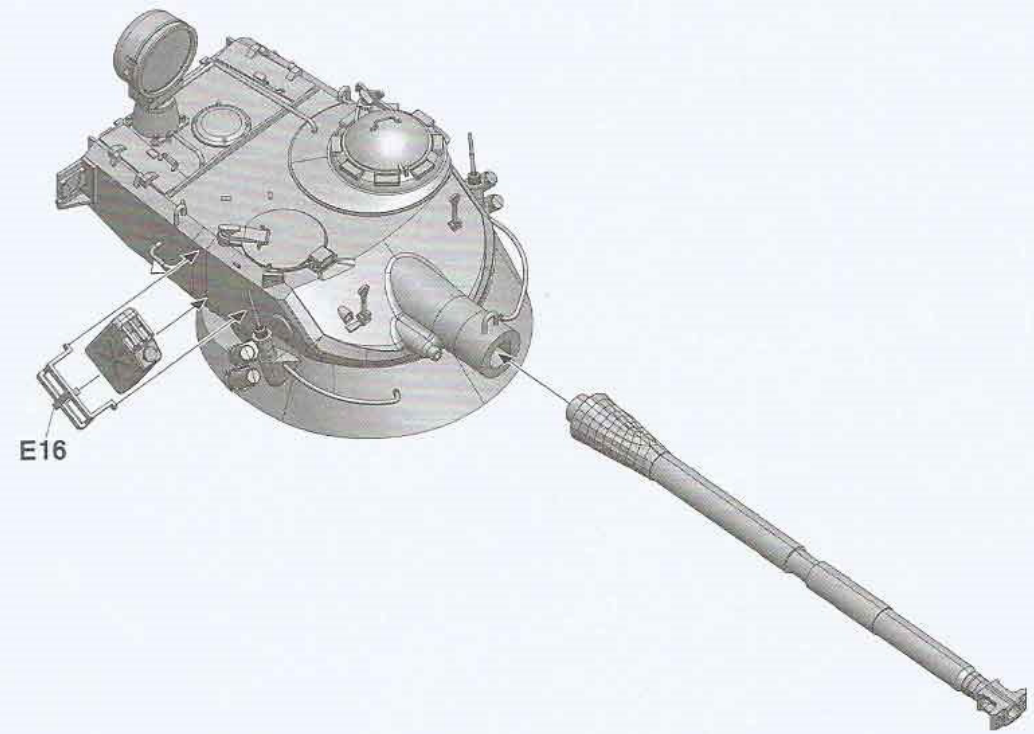
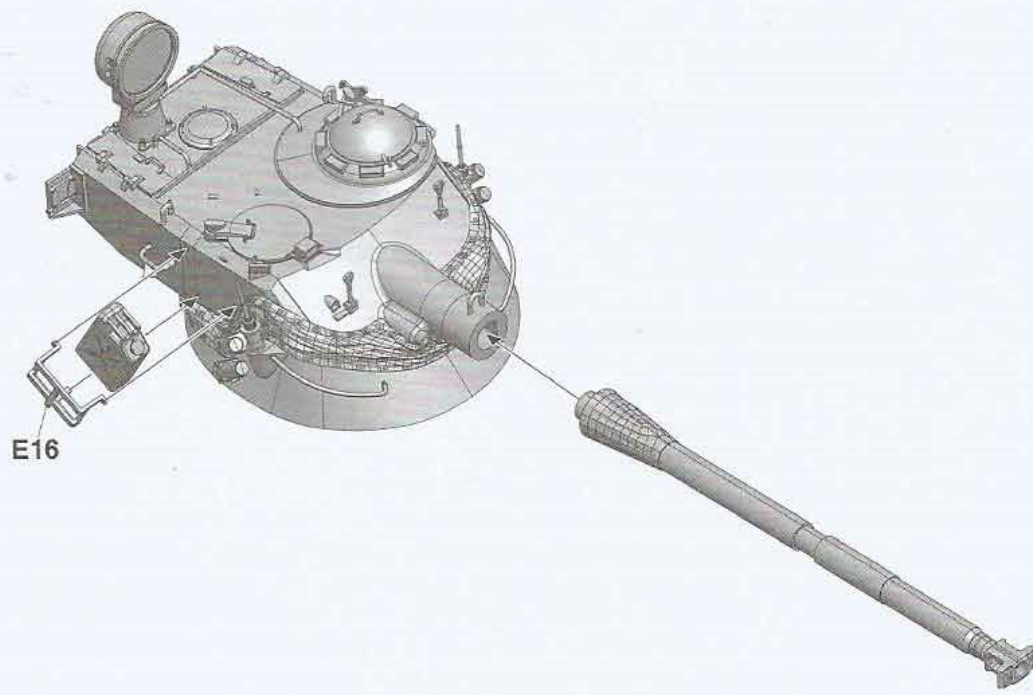
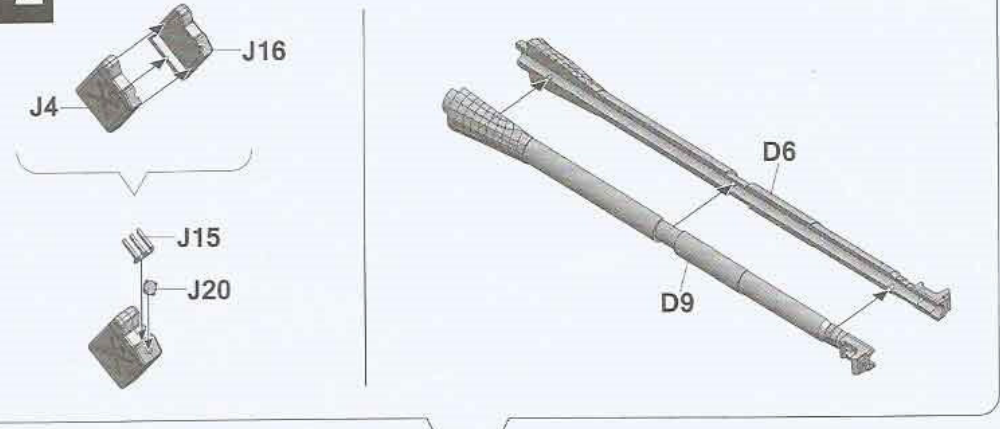

26-1

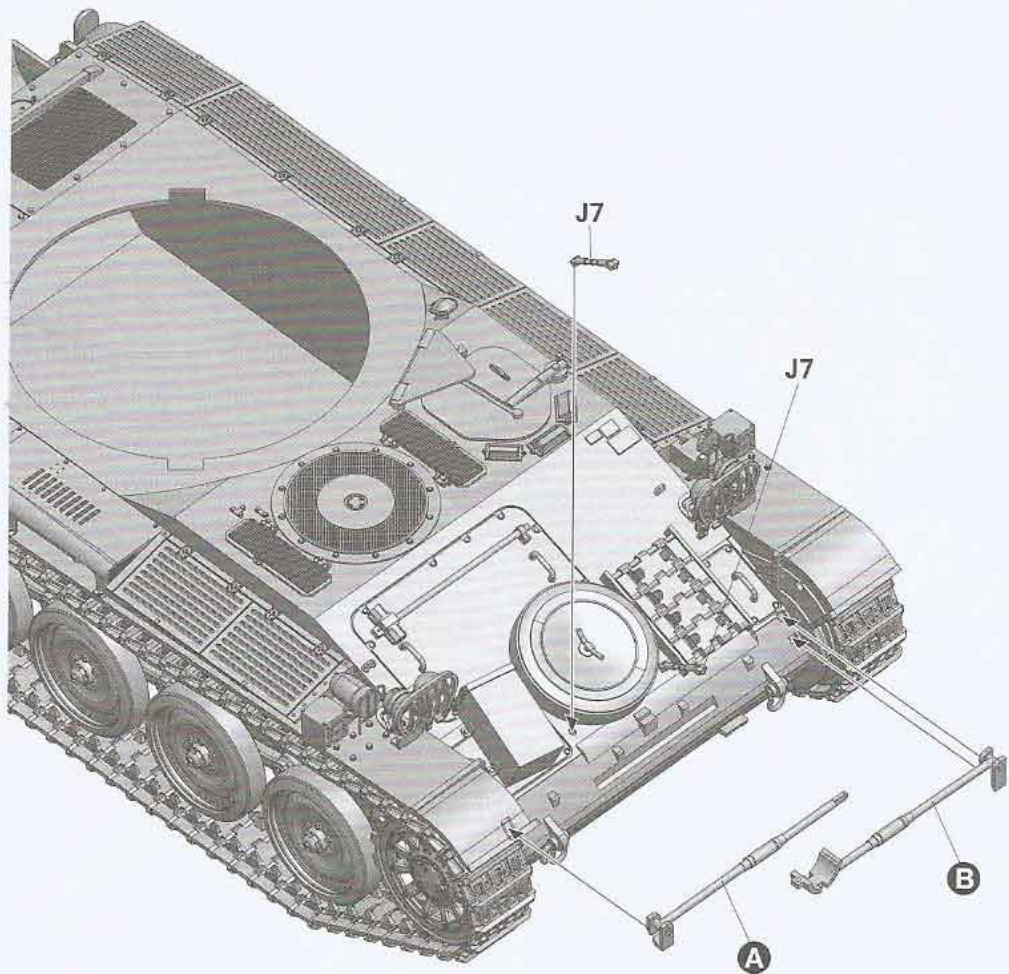
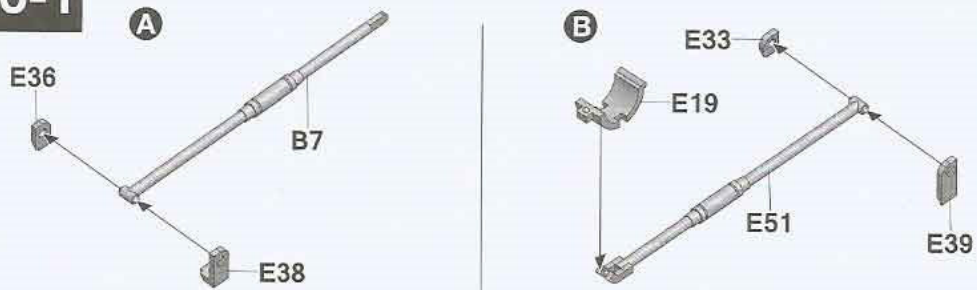

26-2

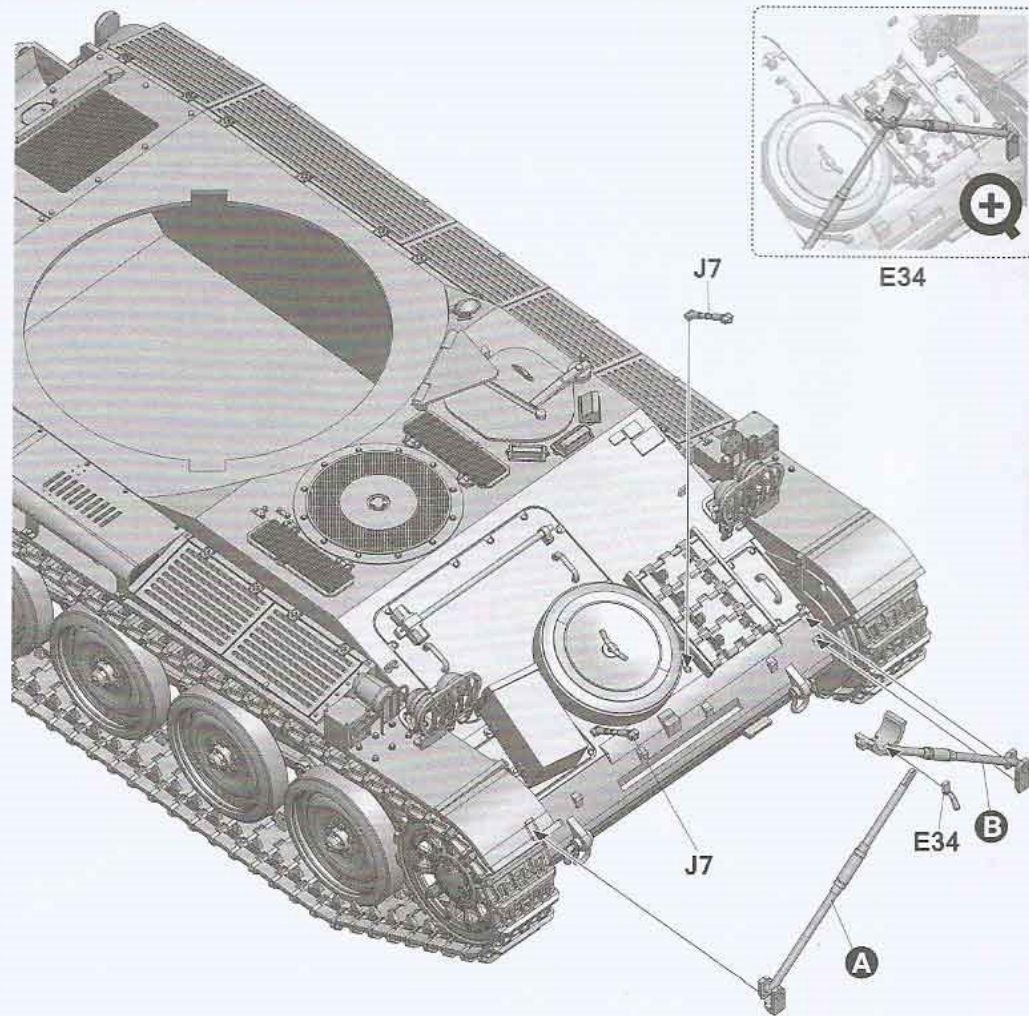
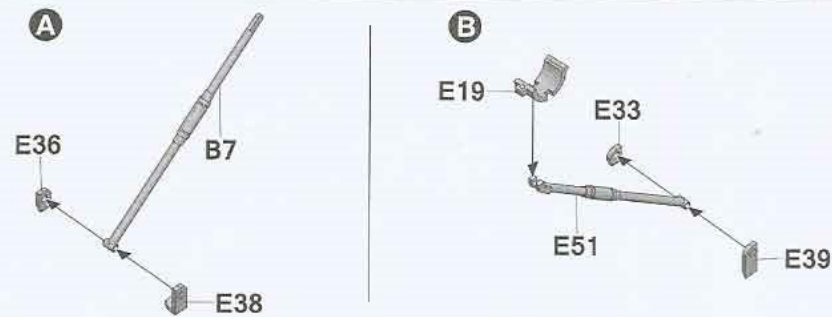

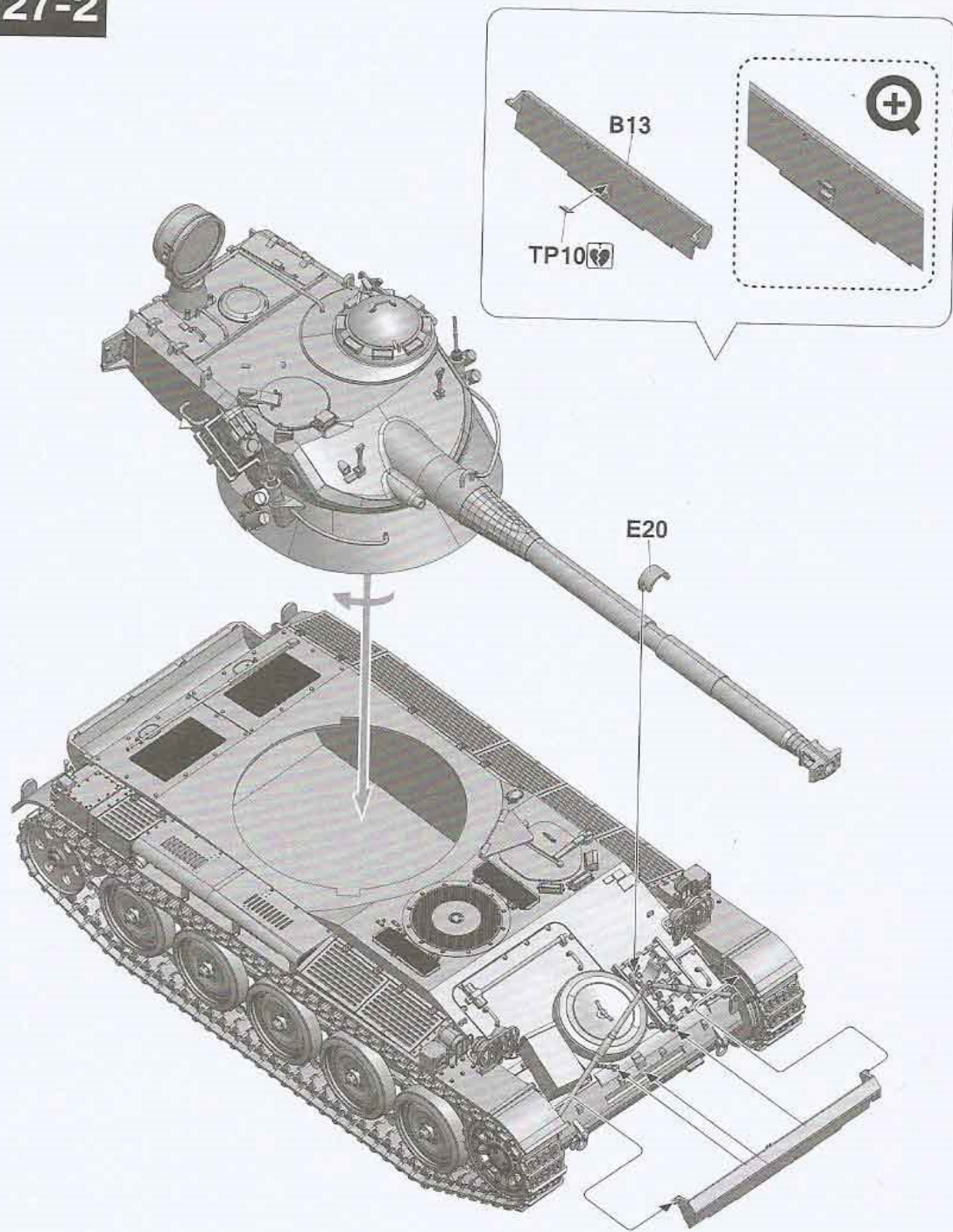
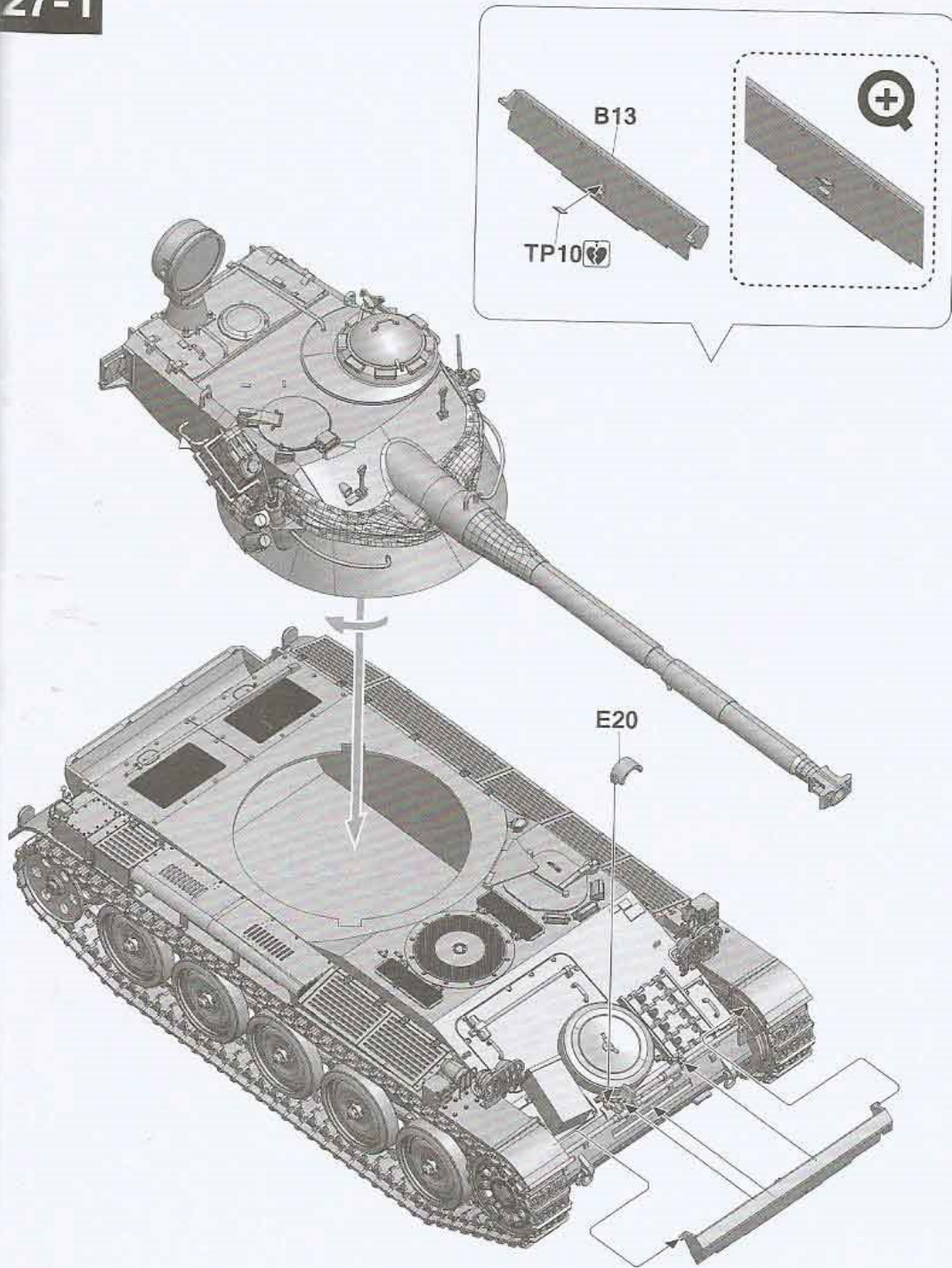

28-1

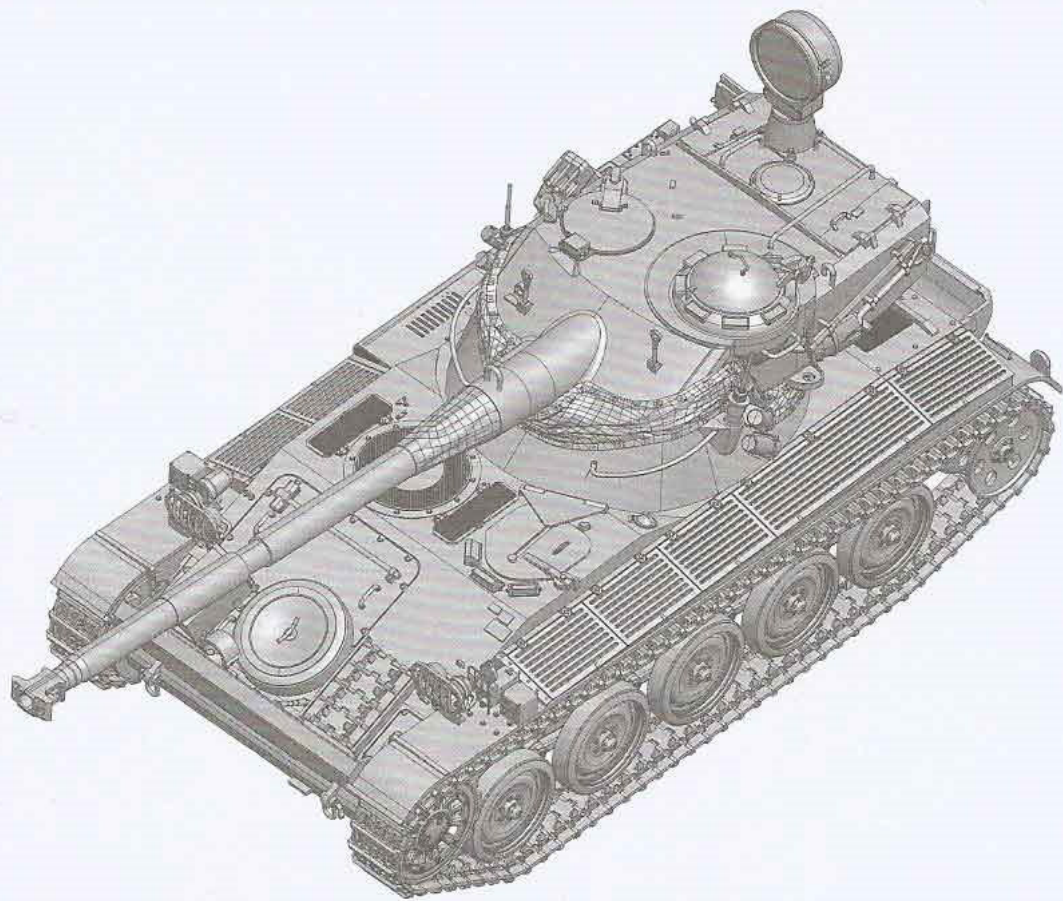

28-2

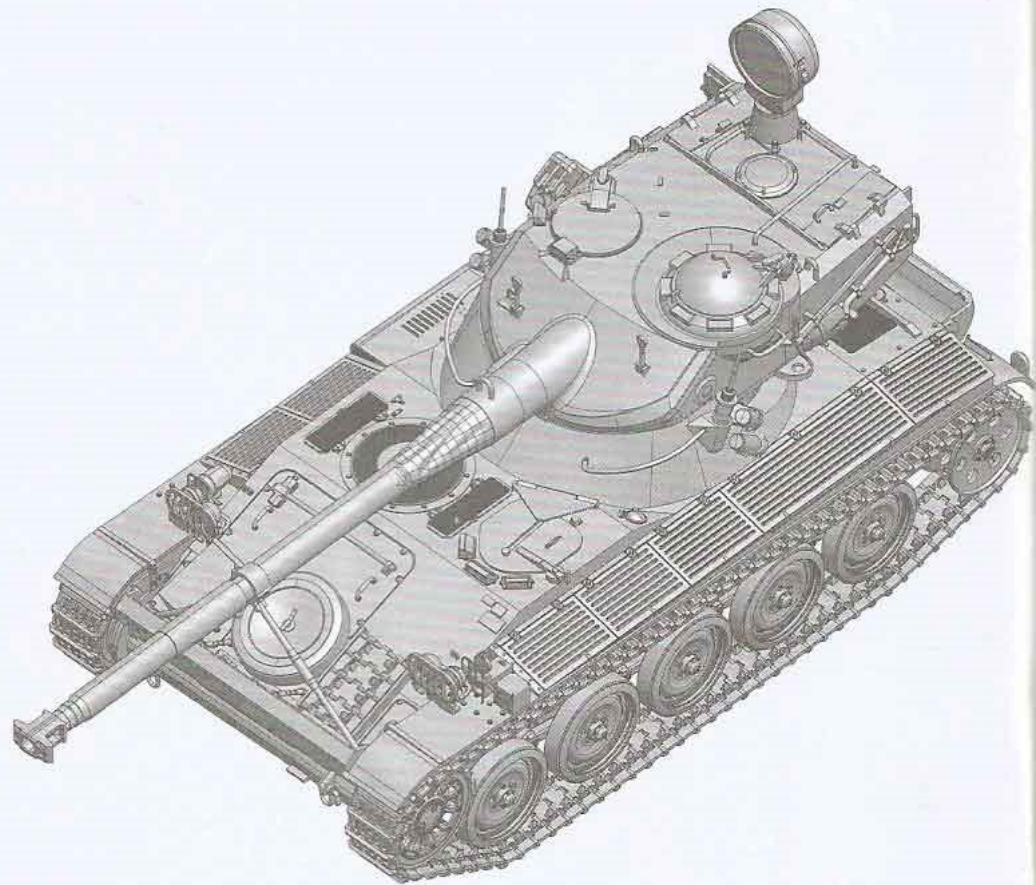

2016/2037

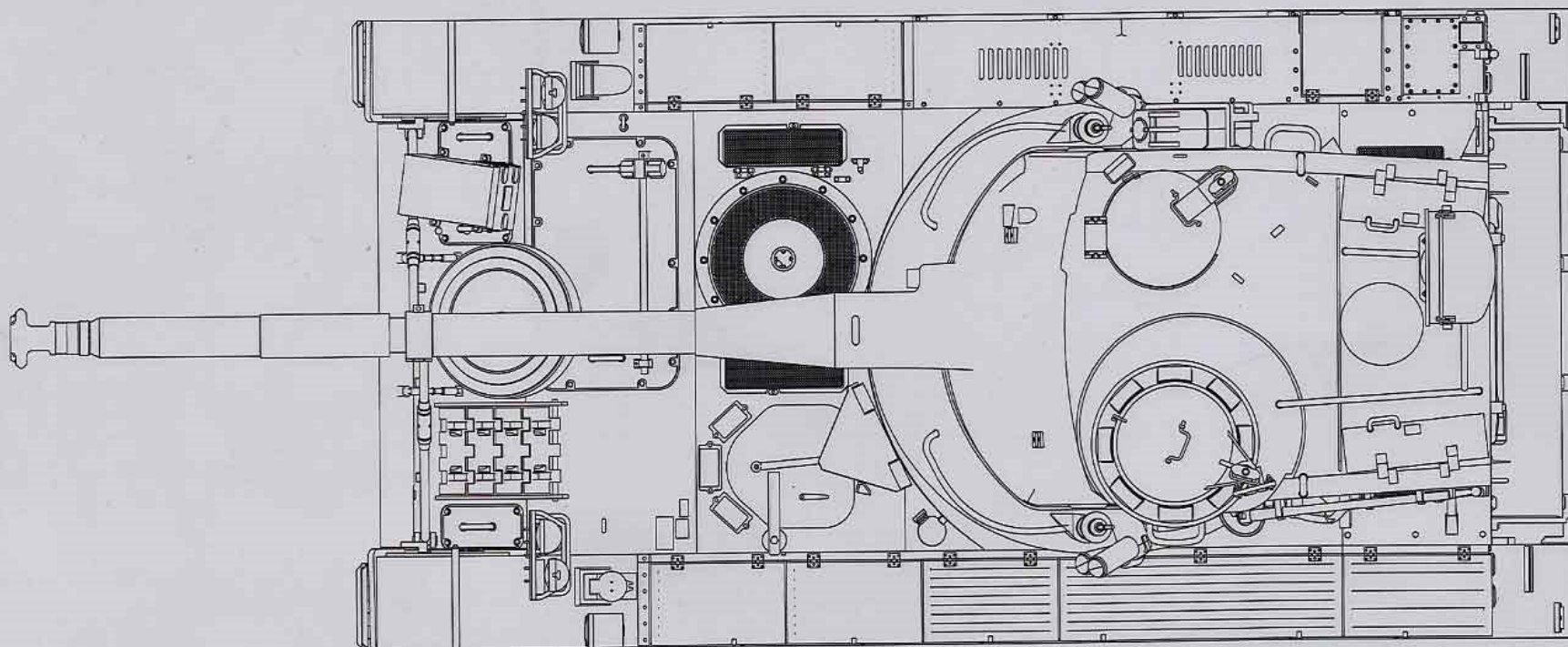

 You can find TAKOM on Facebook.com

AMX-13/90



Color info and profiles by

Painting and Marking Guide

Venezuela Army

A.MIG 031 Rubber & Tire

A.MIG 035 Dark Rock

A.MIG 036 Oil Wood

A.MIG 042 Old Iron

A.MIG 045 Gun Metal

A.MIG 093 Crystal Red

A.MIG 037 Yellow Grey

A.MIG 081 US Olive Drab

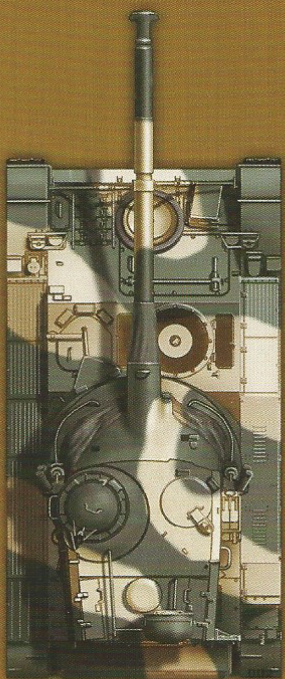

037

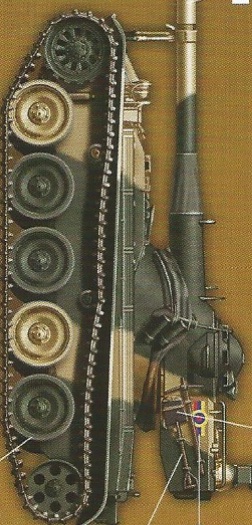

045

036

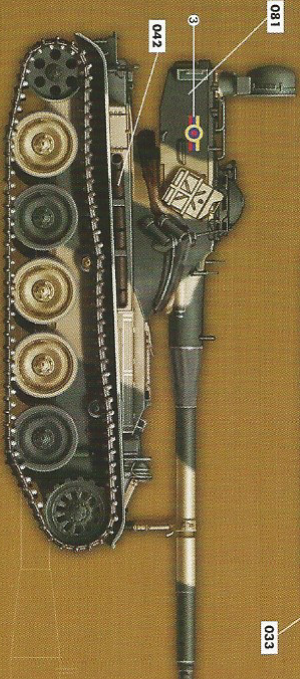

081

042

033

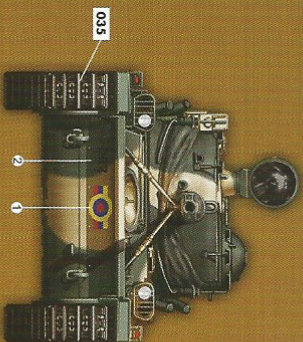

035

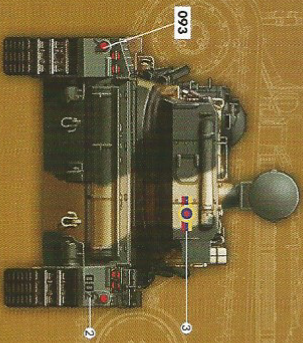

093

9

2

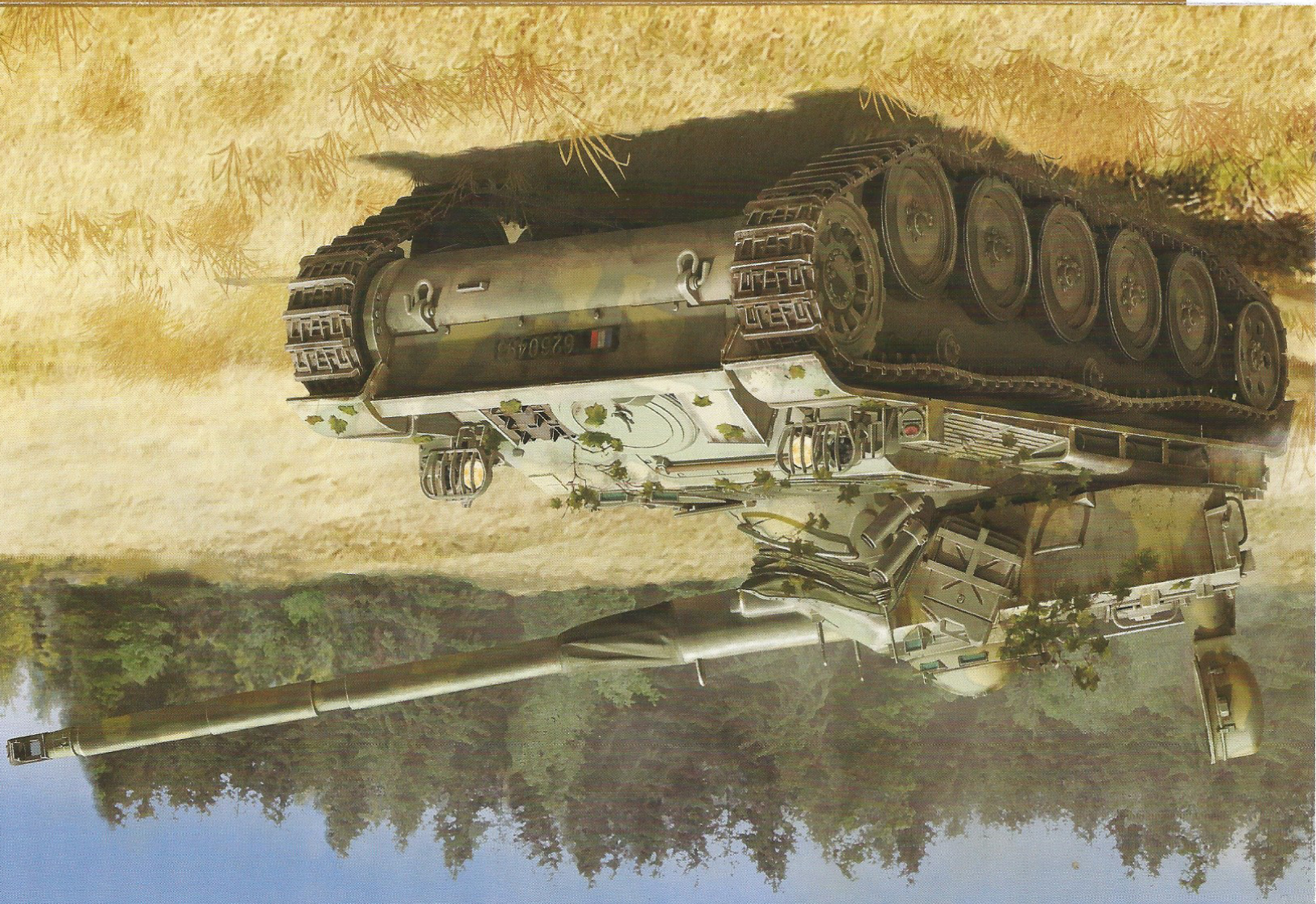

AMX-13/90



Color info and profiles by

Painting and Marking Guide

French Army

AMIG 033 Rubber & Tires

AMIG 042 Old Rust

AMIG 036 Old Wood

AMIG 042 Old Rust

AMIG 045 Gun Metal

AMIG 099 Crystal Red

AMIG 081 US Olive Drab

AMIG 105 Vehicle Dull

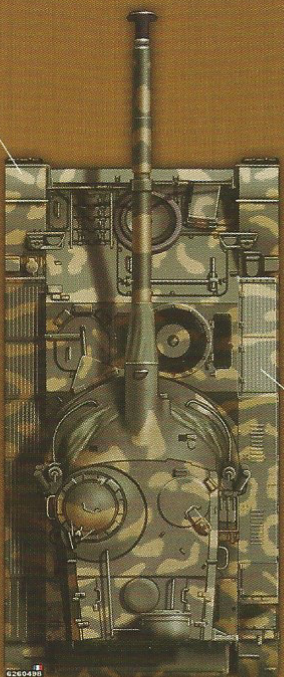

105

081

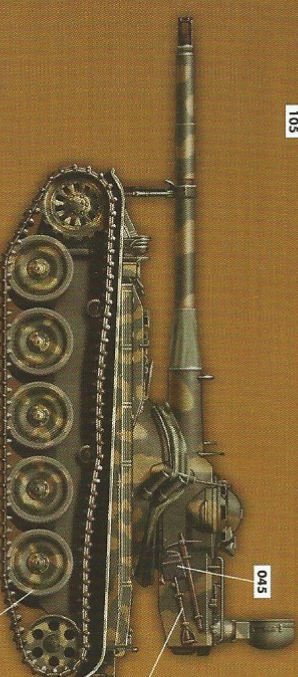

045

036

033

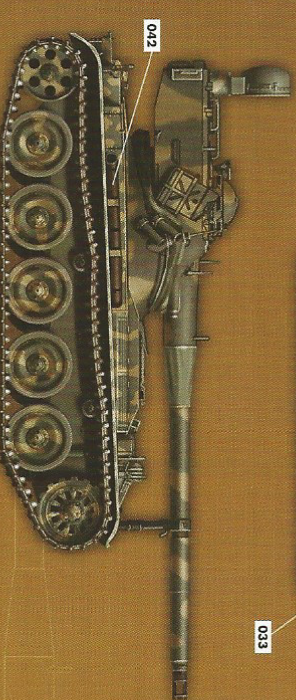

042

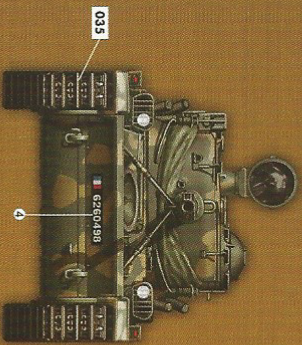

035

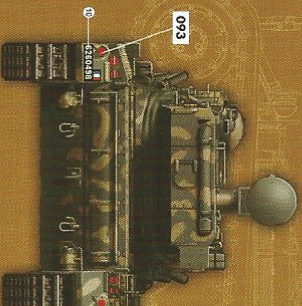

093

TAKOM AMX-13/90 Ref: 2037

AMX-13/90



Color info and profiles by

Painting and Marking Guide

French Army

AMIG 033 Rubber & Tires

AMIG 036 Old Wood

AMIG 036 Old Wood

AMIG 042 Old Rust

AMIG 045 Gun Metal

AMIG 099 Crystal Red

AMIG 071 Kicki

AMIG 081 US Olive Drab

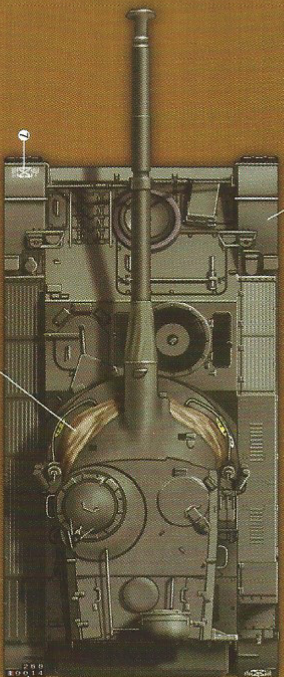

081

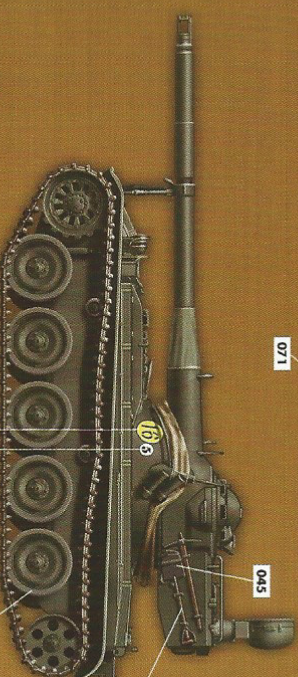

045

036

033

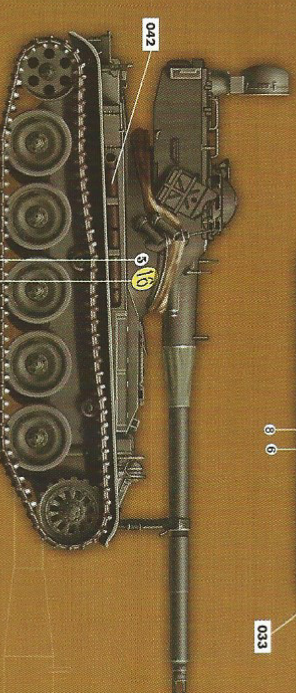

042

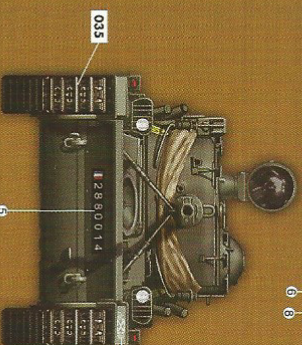

035

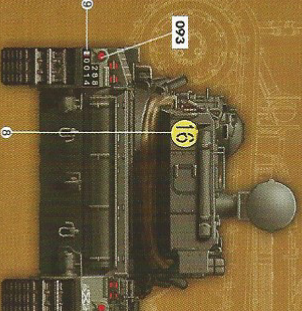

093

TAKOM AMX-13/90 Ref: 2037