

White replaced with green for ease of identification

1/72 VAMPIRES - TELSTARS AEROBATIC TEAM
DEKLS II

32 32 37 37 57 57 48 48

A79-632 A79-637 A79-657 A79-648
A79-632 A79-637 A79-657 A79-648

A79-626 626 26²₆ A79-637 637 37³₇ A79-648 648 48⁴₈ A79-654 654 54⁵₄ A79-657 657 57⁵₇
A79-626 626 26 A79-637 637 37 A79-648 648 48 A79-654 654 54 A79-657 657 57

TELSTARS
TELSTARS

1 2 3 4 5 6 7 8 9 10 11 12 13 14 15 16 17 18 19 20 21 22 23 24 25 26 27 28 29 30 31 32 33

A number of spares have been included on this sheet.

A number of stencil data options included in the sheet that are not covered in instructions. Photo reference material will aid in your selection of the most appropriate marking for the period/scheme you wish to build.

TELSTARS

Circa 1963

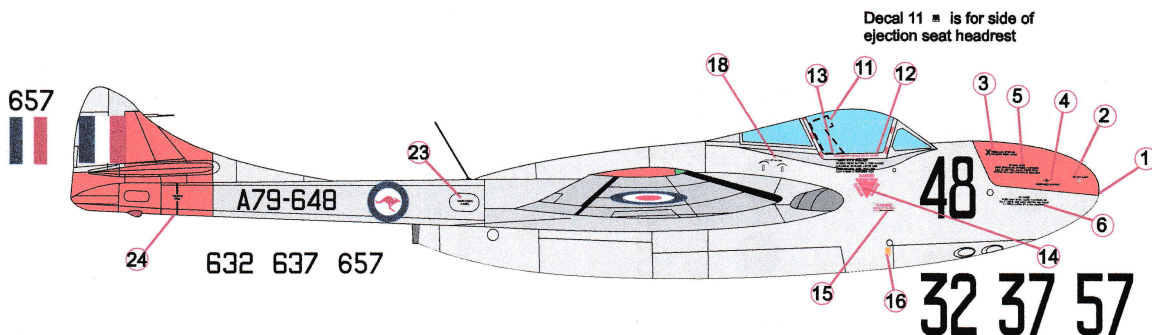

Decal 11 is for side of ejection seat headrest

657

24 632 637 657

48
 32 37 57

Canopy frame decal.

Cut the two parts from decal sheet.

Trim the carrier film close to the marking.

Do not leave carrier film in centre

Apply two halves starting at lower frame of each and join at top of canopy trimming and/or overlapping to a neat finish in the centre.

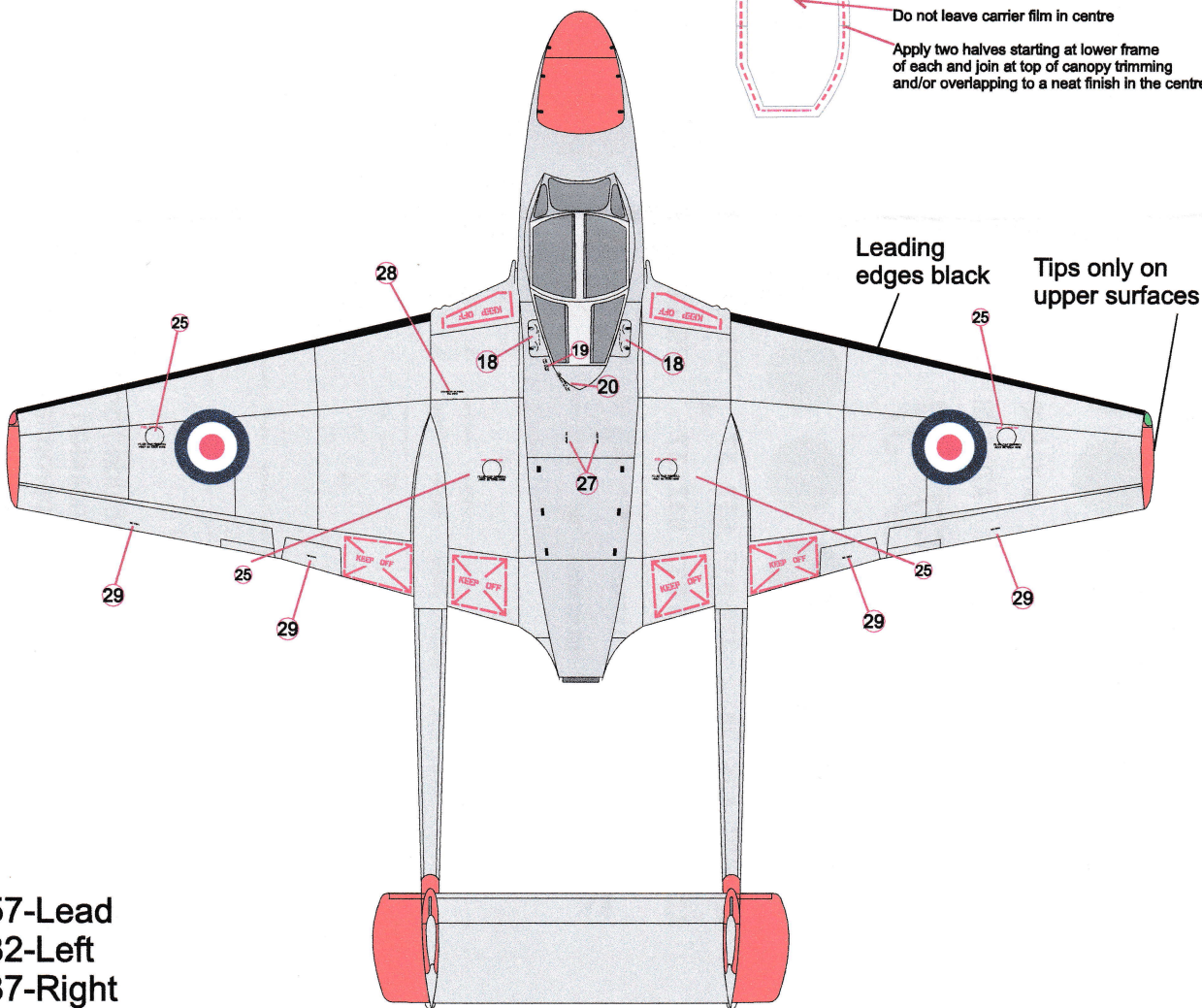
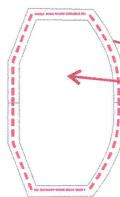

Leading edges black

Tips only on upper surfaces

57-Lead
 32-Left
 37-Right
 48-Box

Pilot:
 Red Flight Suit,
 White name tag above R breast pocket
 White Scarf
 Gold Helmet with Black Tinted Visor

★ TELSTARS ★

Circa 1963

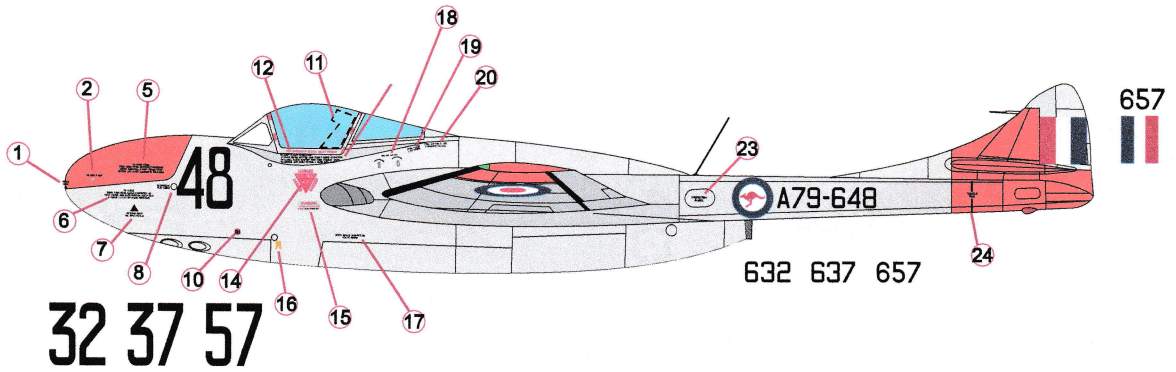

32 37 57

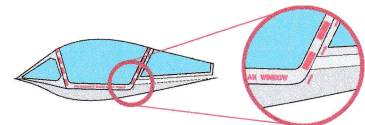

Canopy detail. Indicative only. Arrow markings may not be present on some aircraft. If broken lines are applied, they varied in length/spacing depending on paintshop that last re-marked the frame.

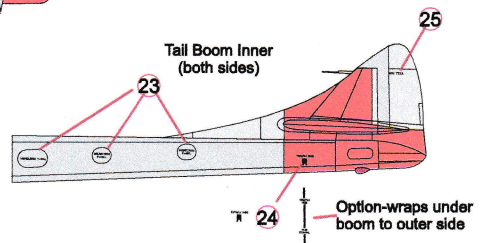
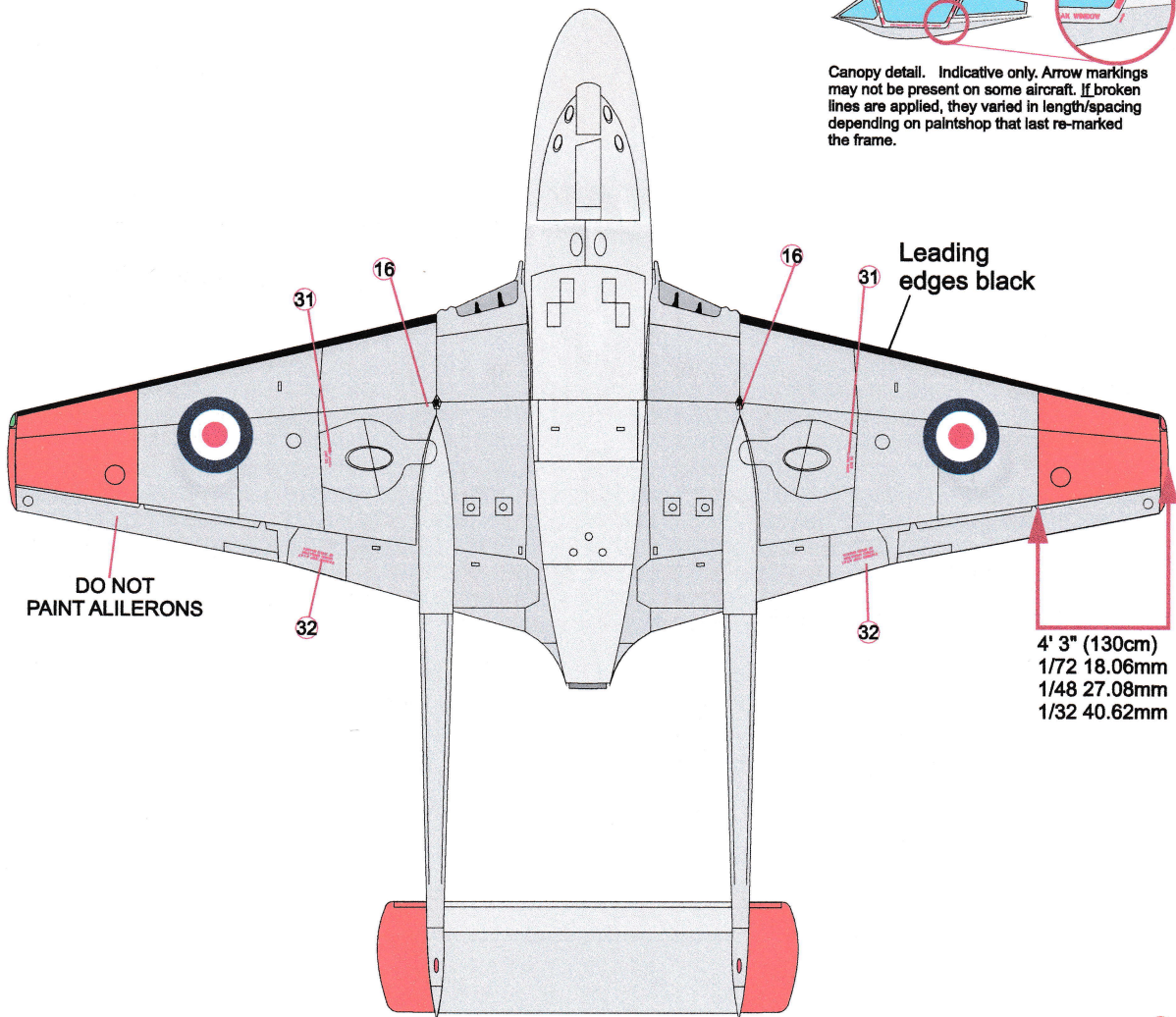

TELSTARS

Circa 1967

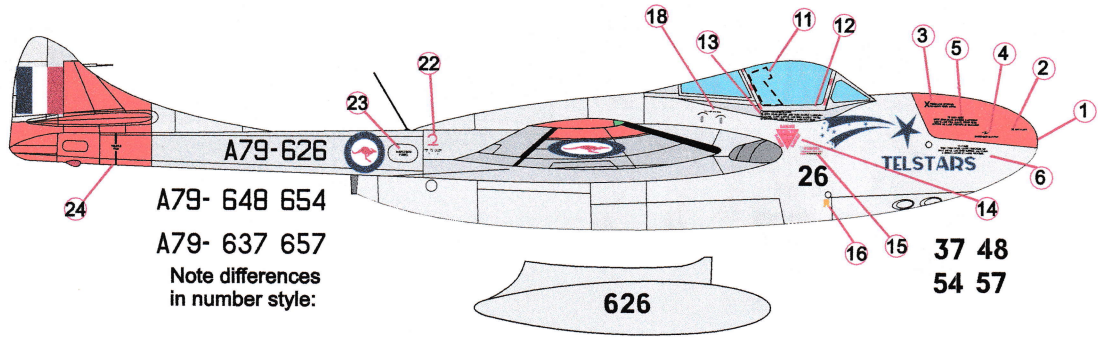

A79- 648 654
 A79- 637 657
 Note differences
 in number style:

37 48
 54 57

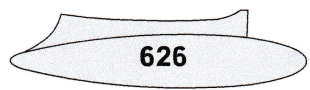

637 654
 648 657

Canopy frame decal.

- Cut the two parts from decal sheet.
- Trim the carrier film close to the marking.
- Do not leave carrier film in centre
- Apply two halves starting at lower frame of each and join at top of canopy trimming and/or overlapping to a neat finish in the centre.

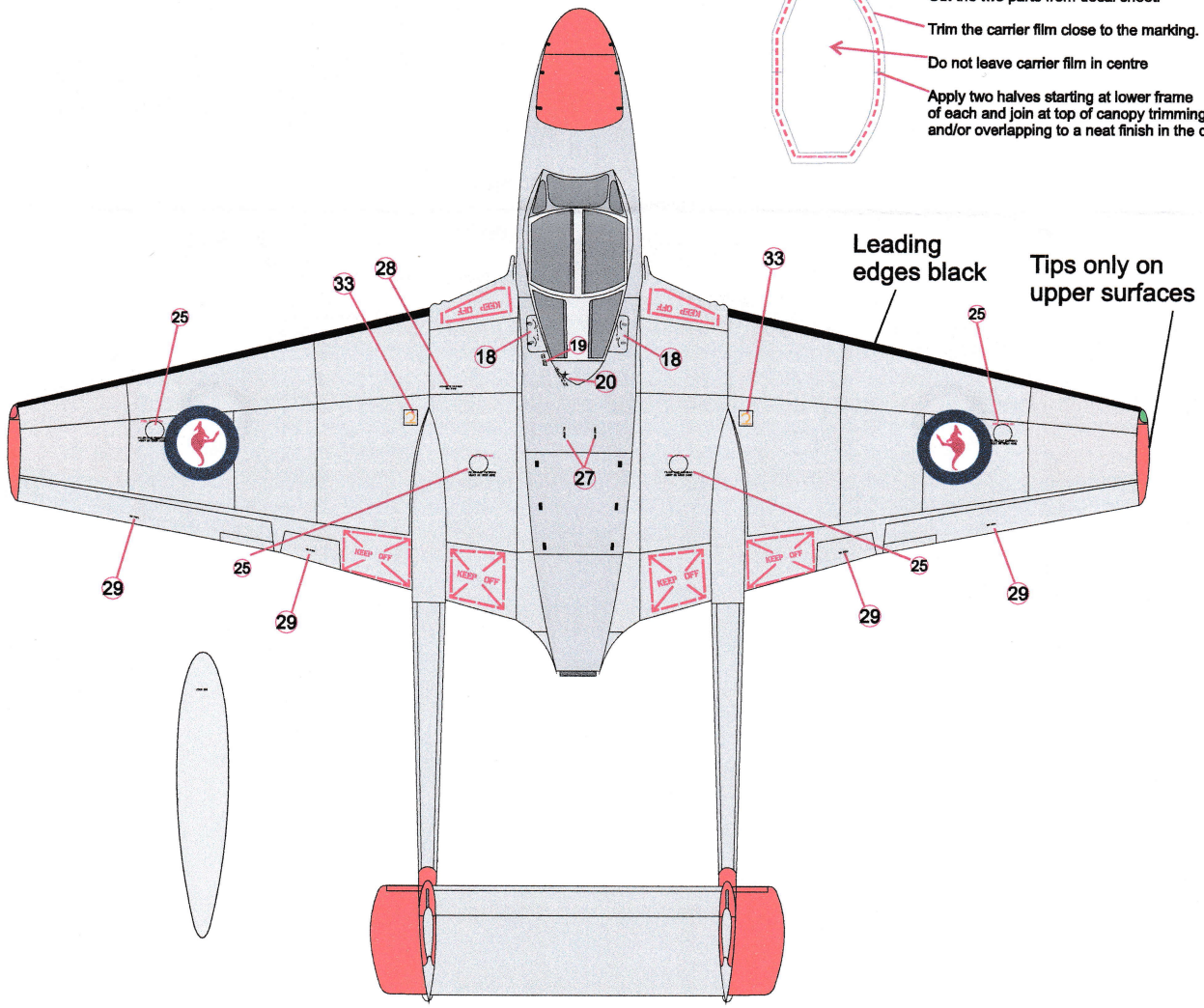
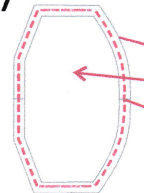

Leading edges black
 Tips only on upper surfaces

★ TELSTARS ★

Circa 1967

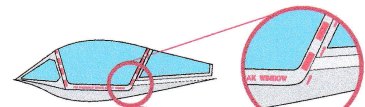
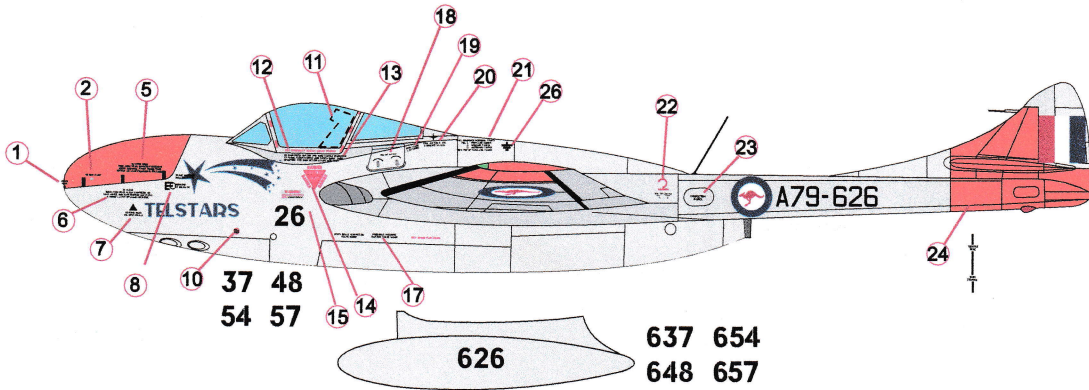

Canopy detail. Indicative only. Arrow markings may not be present on some aircraft. If broken lines are applied, they varied in length/spacing depending on paintshop that last re-marked the frame.

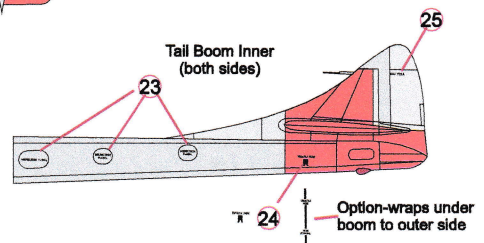
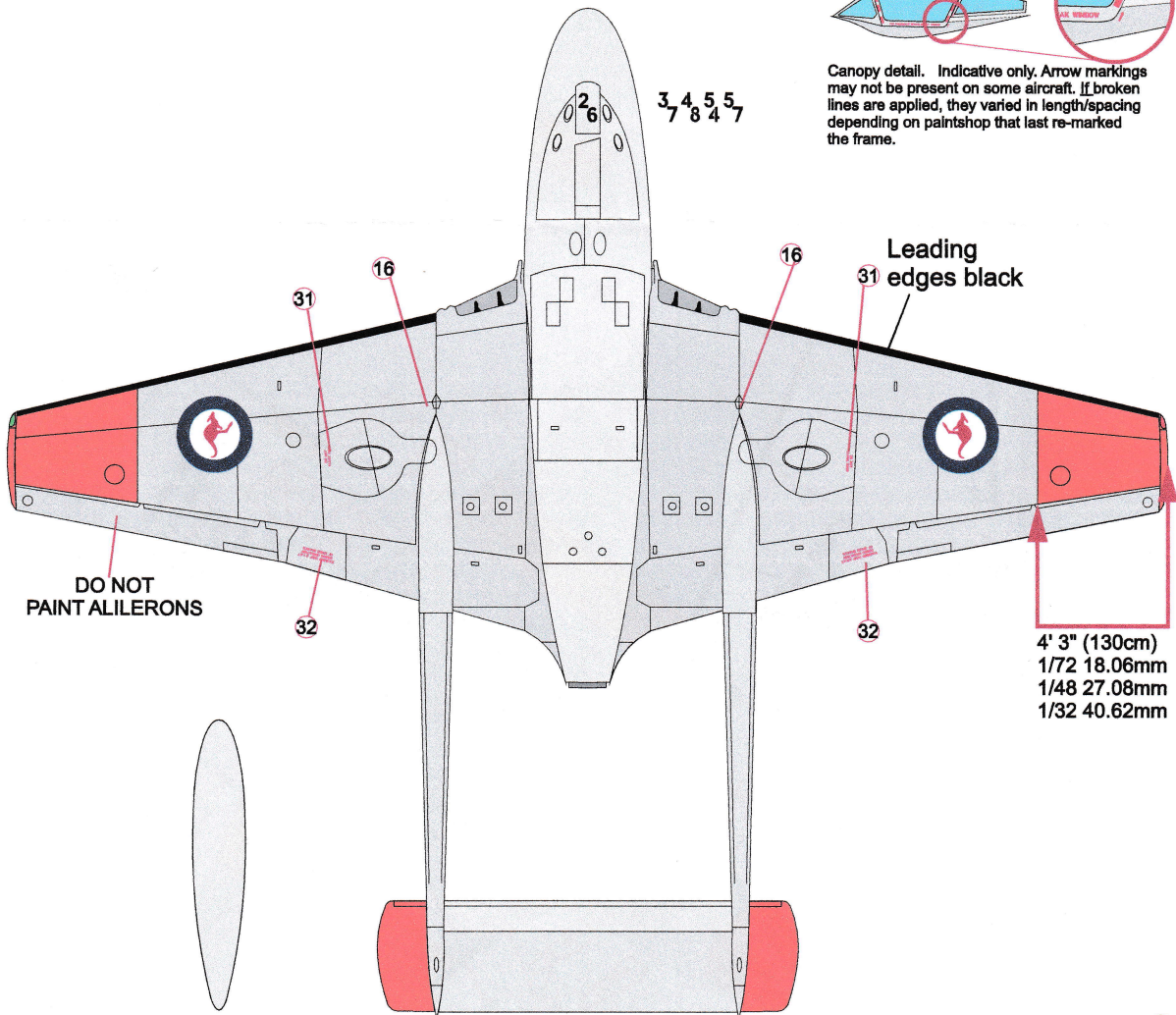

DH VAMPIRE

STENCIL DATA PLACEMENT AND PAINT GUIDE

Decal 11 is for side of ejection seat headrest

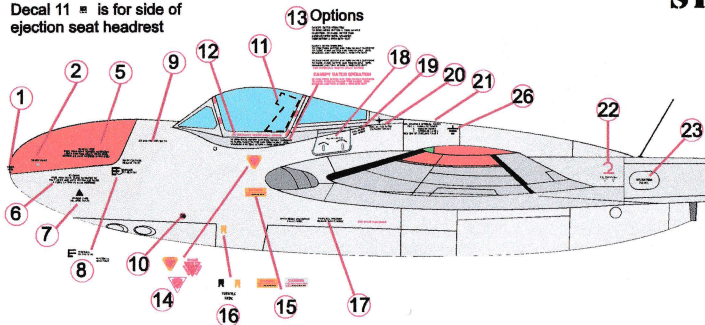

Option-wraps under boom to inner side

24

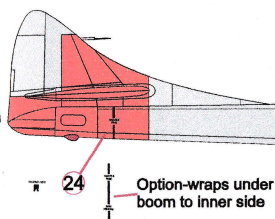

Option-wraps under boom to inner side

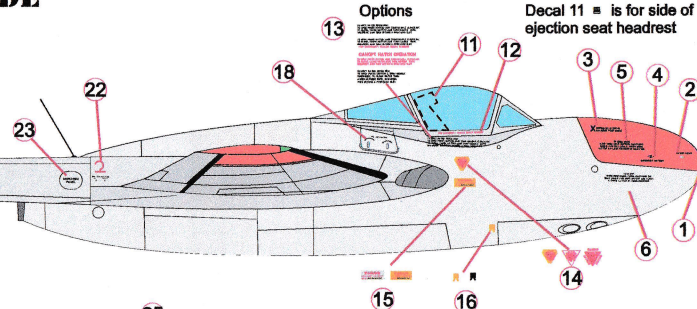

Decal 11 is for side of ejection seat headrest

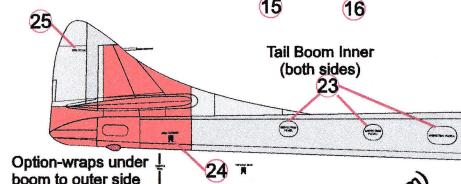

Tail Boom Inner (both sides)

23

Option-wraps under boom to outer side

24

4' 3" (130cm)
1/72-18.08mm
1/48-27.08mm
1/32-40.62mm

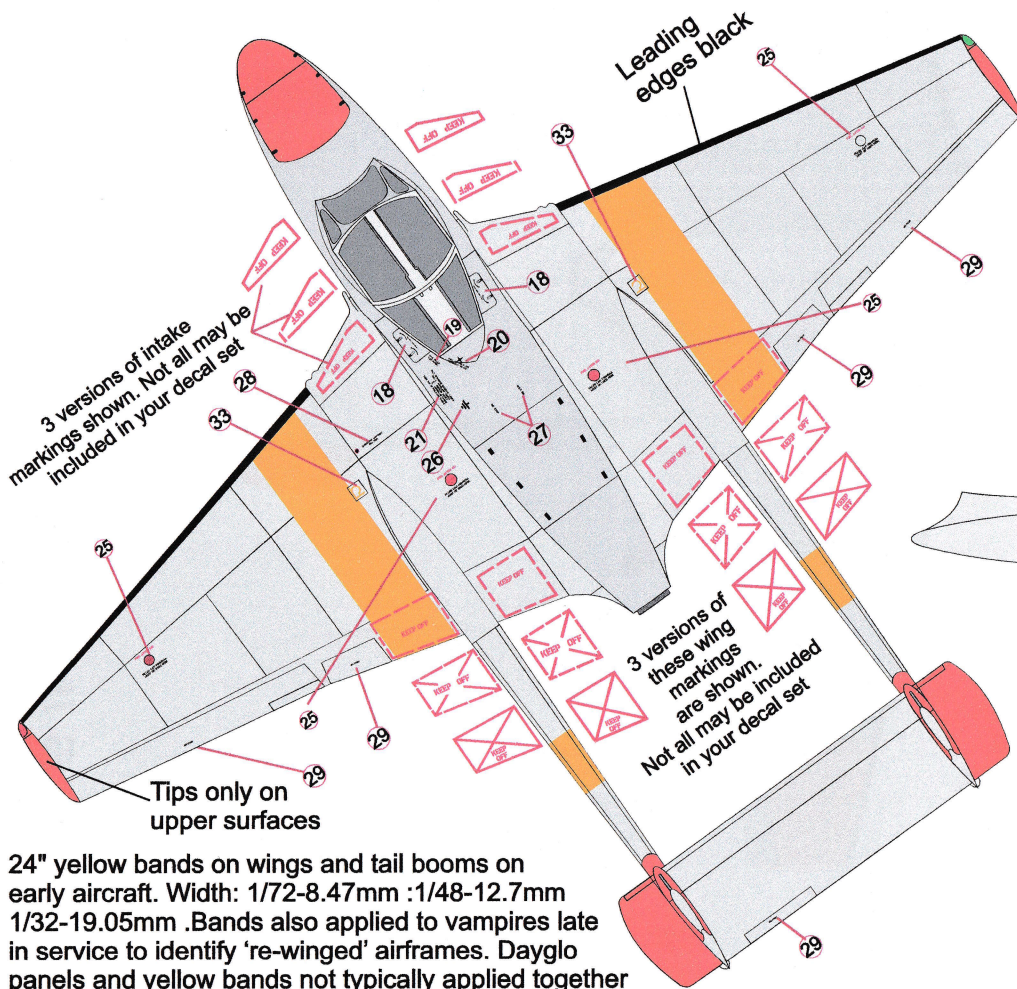

3 versions of these wing markings are shown. Not all may be included in your decal set

3 versions of intake markings shown. Not all may be included in your decal set

Tips only on upper surfaces

24" yellow bands on wings and tail booms on early aircraft. Width: 1/72-8.47mm :1/48-12.7mm 1/32-19.05mm .Bands also applied to vampires late in service to identify 're-winged' airframes. Dayglo panels and yellow bands not typically applied together

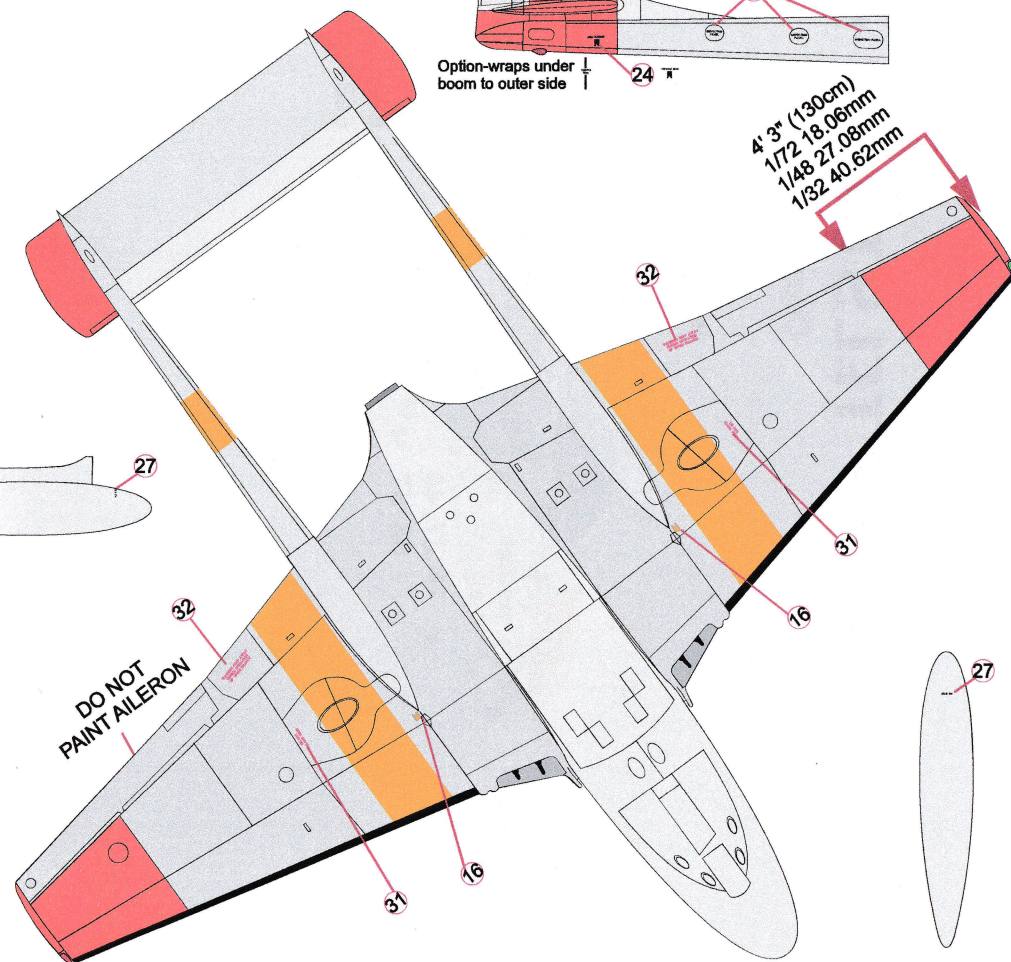

DO NOT PAINTAILERON

USING DEKLS II

Thank You

Thank you for your purchase of these expertly produced, high quality, short print run decals.

CAUTION: HANDLE WITH CARE

To keep the thickness of the decal to a minimum, it has not been coated. Do not place anything on the face of the decal that may scratch it (ie model kit / tools/ etc).

They are a little different!





Unlike the commercially produced decals that come with your model kit, DEK L's II are LED printed using white ink technology.

Removal from the sheet

As with most short production run decals these are printed on a single continuous piece of decal film. Decals will need to be carefully cut from the sheet individually.

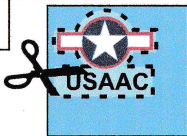
Whites

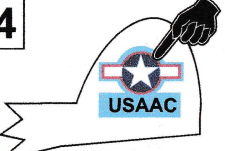
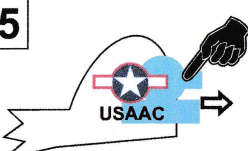
Where appropriate, 'whites' are provided as an option, to be placed on the model, before the final decal. Whites should be left to properly set prior to application of the final decal.

<p>1</p>  <p>- Carefully cut individual decals from the sheet.</p>	<p>2</p>  <p>- Place a few drops of water on the model to aid initial adhesion. - Soak decal in luke warm water for approx 10-15 sec.</p>	<p>3</p>  <p>- After removing from water, wait 10-15 sec for decal to release from backing paper. - Decal is ready to apply when transparency can be moved on the backing</p>
<p>4</p>  <p>- Position over the spot that you want the decal.</p>	<p>5</p>  <p>- Gently slide away backing paper from under the decal. - A few drops of water will assist if repositioning is required.</p>	<p>6</p>  <p>- Remove air bubbles or excess water by gently pressing down on the decal with a soft cloth.</p>

- Decals adhere best to non porous, gloss surfaces. Use on matt surfaces is NOT recommended.
- Solvents and setters may be used, however they should first be tested on an unused portion of the decal sheet.

Extra Decals

Additional decals not detailed on the instruction sheet may be included. These are provided for known marking variations on specific aircraft. Modellers may wish to use these after consulting references.

Replacement or additional individual decals can be provided for a small fee.

Suggestions or Improvements

I am always open to suggestions for new decals or improvements and I do appreciate your feedback.

Thank You!!

Derek

www.dekls.com.au
[stores.ebay.com.au/DEK-LS-HOBBY](https://www.ebay.com.au/DEK-LS-HOBBY)
www.facebook.com/deklsdecals/
sales@dekls.com.au

www.dekls.com.au
[stores.ebay.com.au/DEK-LS-HOBBY](https://www.ebay.com.au/DEK-LS-HOBBY)
www.facebook.com/deklsdecals/
sales@dekls.com.au

DEKLS
FOR THE ENTHUSIAST

RAN 'Ramjets' Display Team

1/32
1/48
1/72
Other scales on request

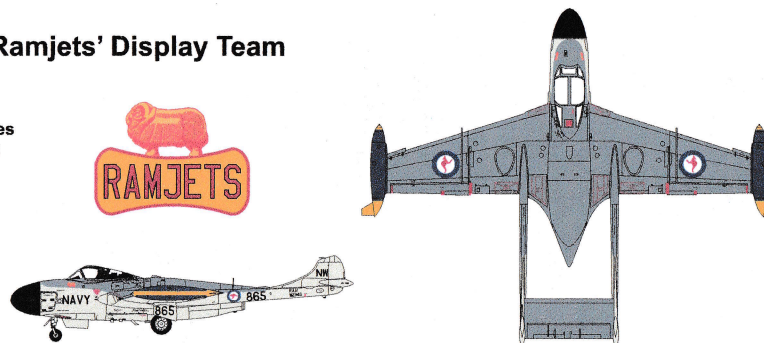

SAAB Tunnan Swedish Air Force F3 Malmslätt

1/32
1/48
1/72
Other scales on request

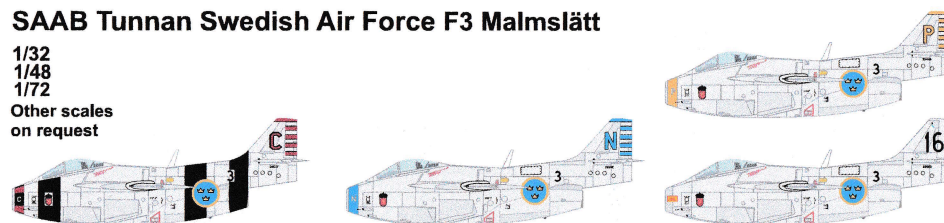

SAAB Tunnan Swedish Air Force 'Test and Target Tunnans'

1/32
1/48
1/72
Other scales on request

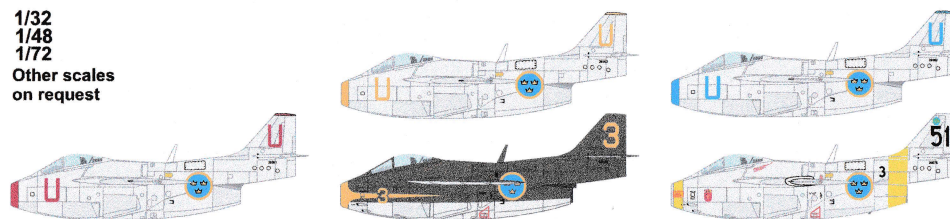

RAAF P-8A Poseidon 10/11 Squadron

1/72
1/144
1/200
1/300

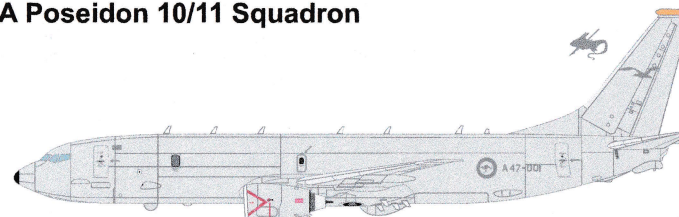

PROUDLY AUSTRALIAN

SOUTH AUSTRALIA