

4807 TORNADO FLAPS, SLATS, WING GLOVES AND TAILERON PIVOT PLATES.
 TO SUIT ITALERI KIT NO.834.

ALL DRAWINGS SHOW LEFT HAND ITEMS ONLY. REPEAT ALL PROCEDURES FOR RIGHT HAND ALSO.
 FIGURES IN BRACKETS INDICATE CORRESPONDING ITEMS FOR RIGHT HAND SIDE.

REMOVE SHADED AREAS BEFORE
 JOINING WING HALVES.

UPPER LEFT WING
 KIT PART 21c.

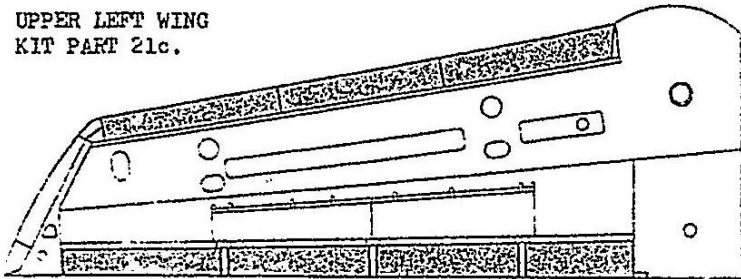

LOWER LEFT WING
 KIT PART 18c.

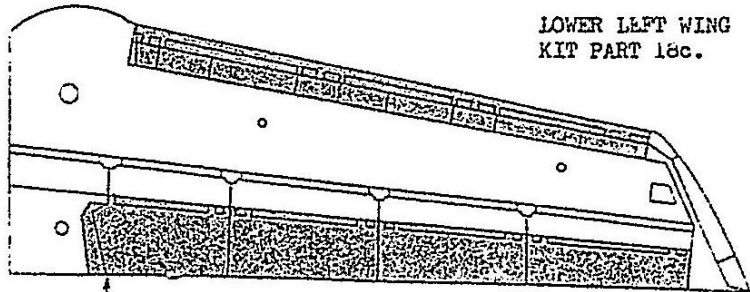

KIT PANEL LINE IS INCORRECTLY POSITIONED.
 USE RESIN FLAPS, 3 AND 11, AS A GUIDE OR
 TEMPLATE TO REMOVE CORRECT AREA OF PLASTIC.

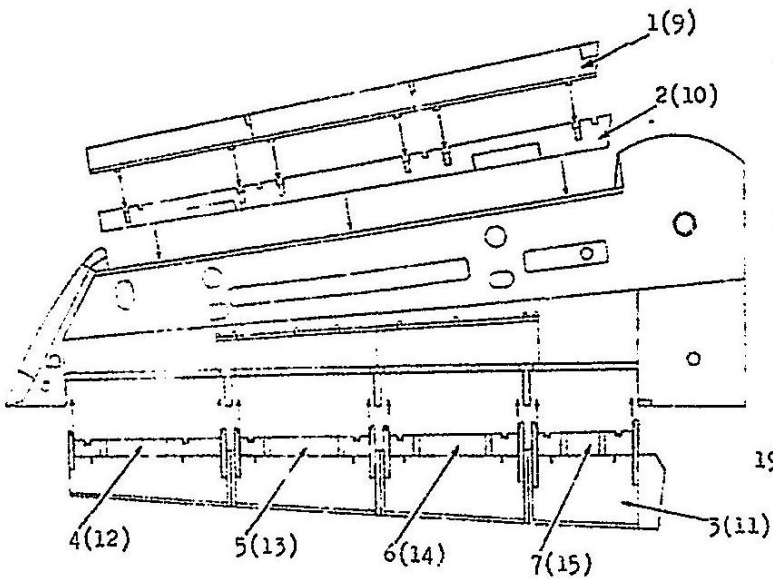

MAKE ACTUATOR SCREWS FROM ROD
 OR WIRE (TWELVE PER WING).

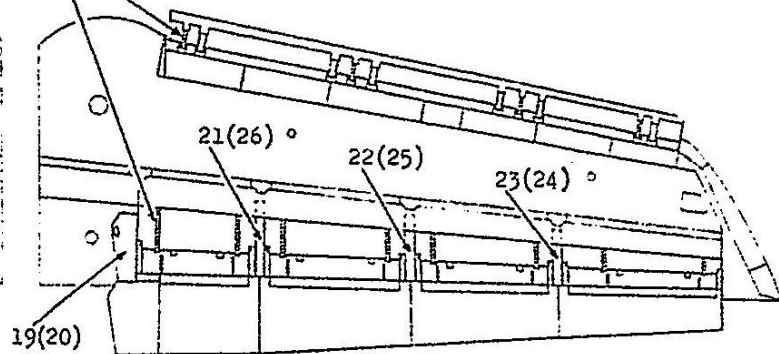

SMALL TAB ON PARTS 21 TO 26 LOCATE
 BETWEEN WING HALVES.

NOTE: POSITIONS OF FLAPS AND SLATS CAN VARY. REFER TO PHOTOS OF AIRCRAFT FOR DESIRED ANGLES
 (REMEMBER THAT AS FLAPS ARE LOWERED THEY ALSO TRAVEL REARWARDS)

