

**1/24 Super detail engine bay  
kit for Ford Escort RS  
Cosworth Tamiya/Domino**

**24T035**

**USCP**



ukrainian scale cars production

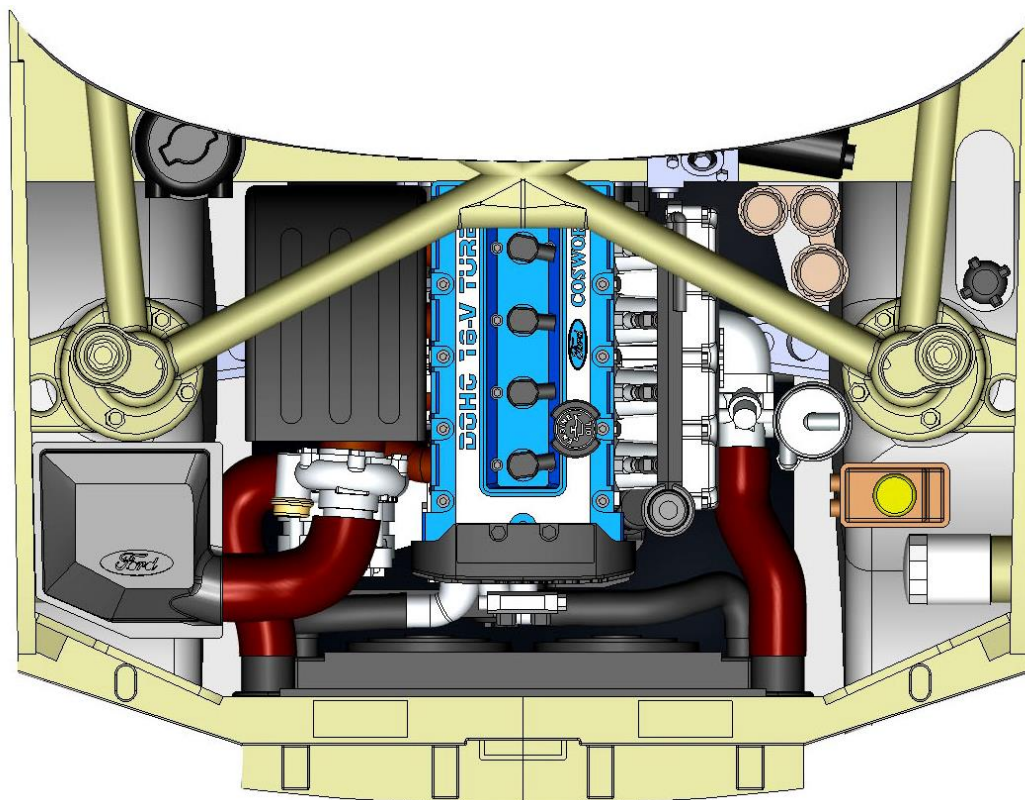

***Cosworth YB Engine***  
***+ Ford Escort RS Rally Engine Bay***

**ASSEMBLY INSTRUCTION**

**2019**

**Made in Ukraine**

**Parts:**

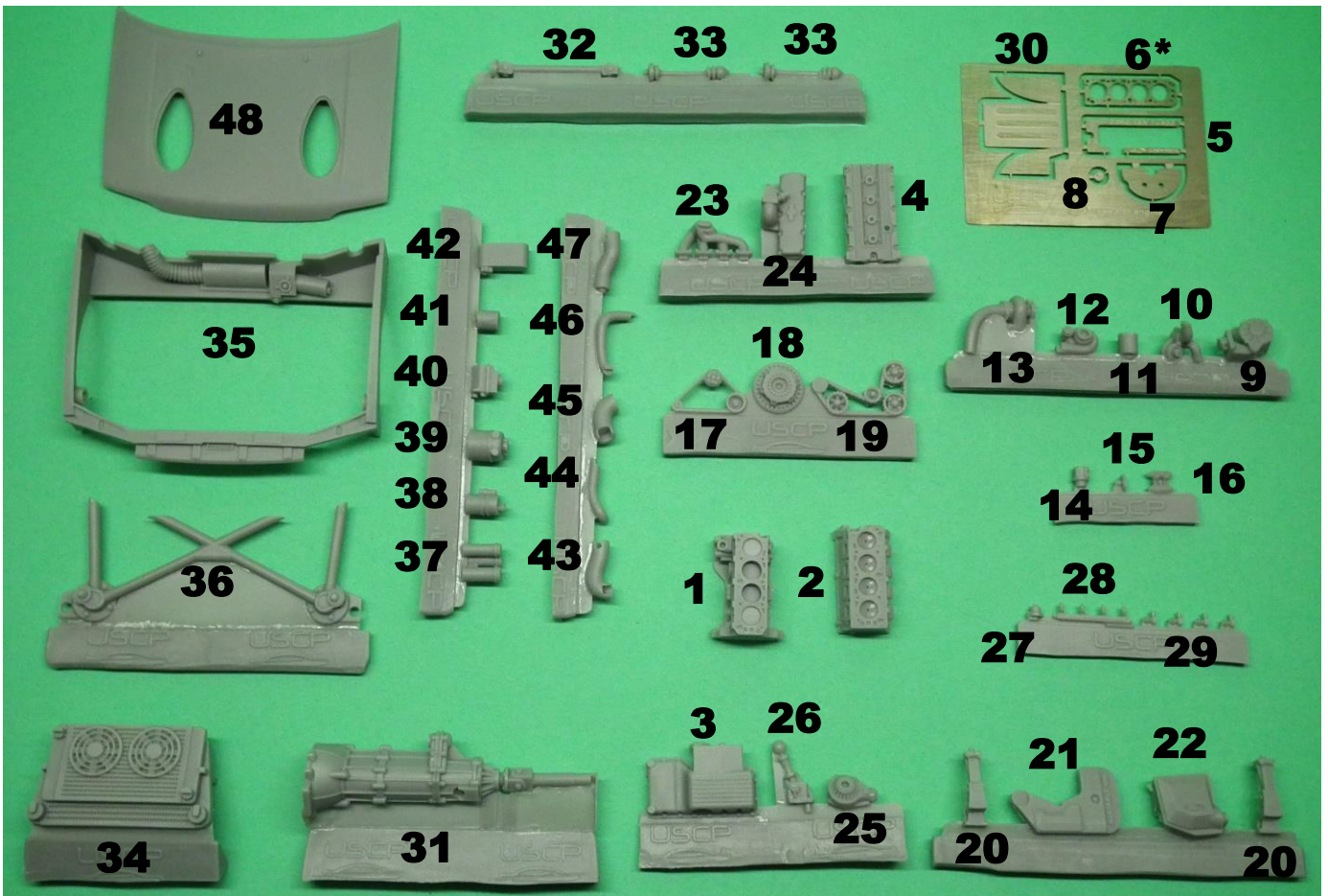

**\*PE part #6 not used in assembling**

<b>Colors:</b>	<b>F – exhaust color</b>
<b>A – semi gloss black</b>	<b>G – gold</b>
<b>B – aluminum</b>	<b>H – white</b>
<b>C – steel</b>	<b>I – body color</b>
<b>D – flat black</b>	<b>J – orange-red</b>
<b>E – metallic blue</b>	<b>K – moon white</b>

## 1. Engine block, head, oil pan

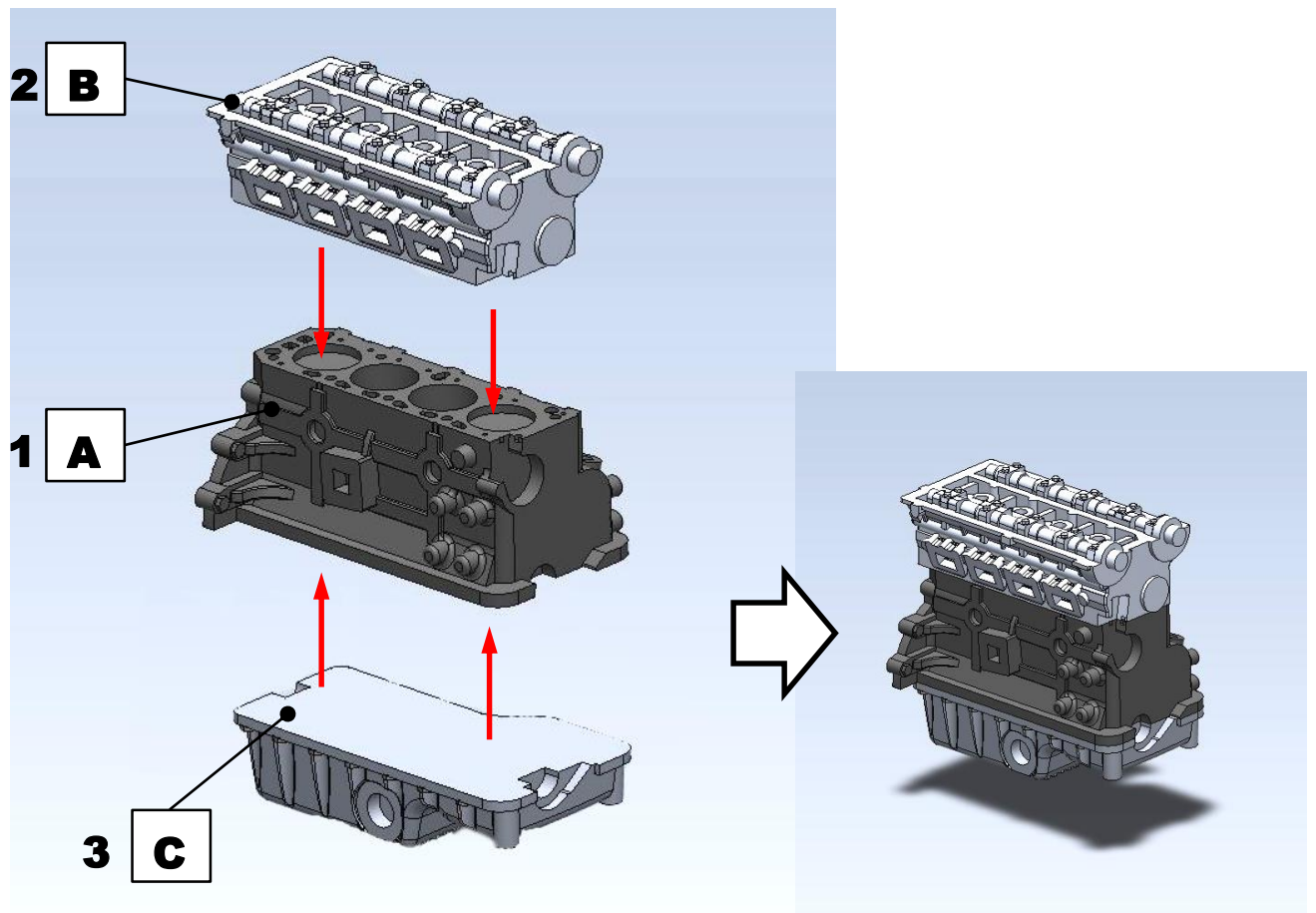

## 2. Valve cover

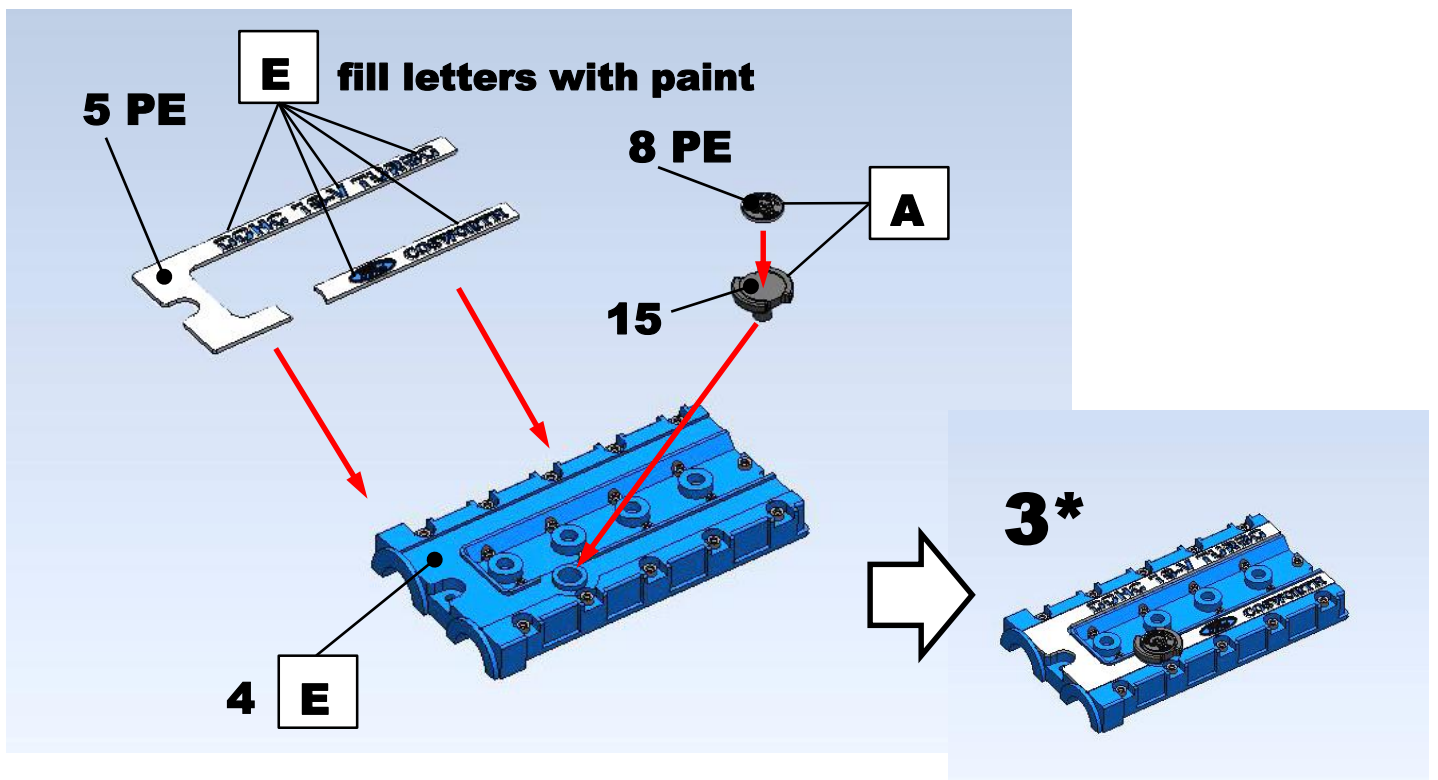

### 3. Engine equipment

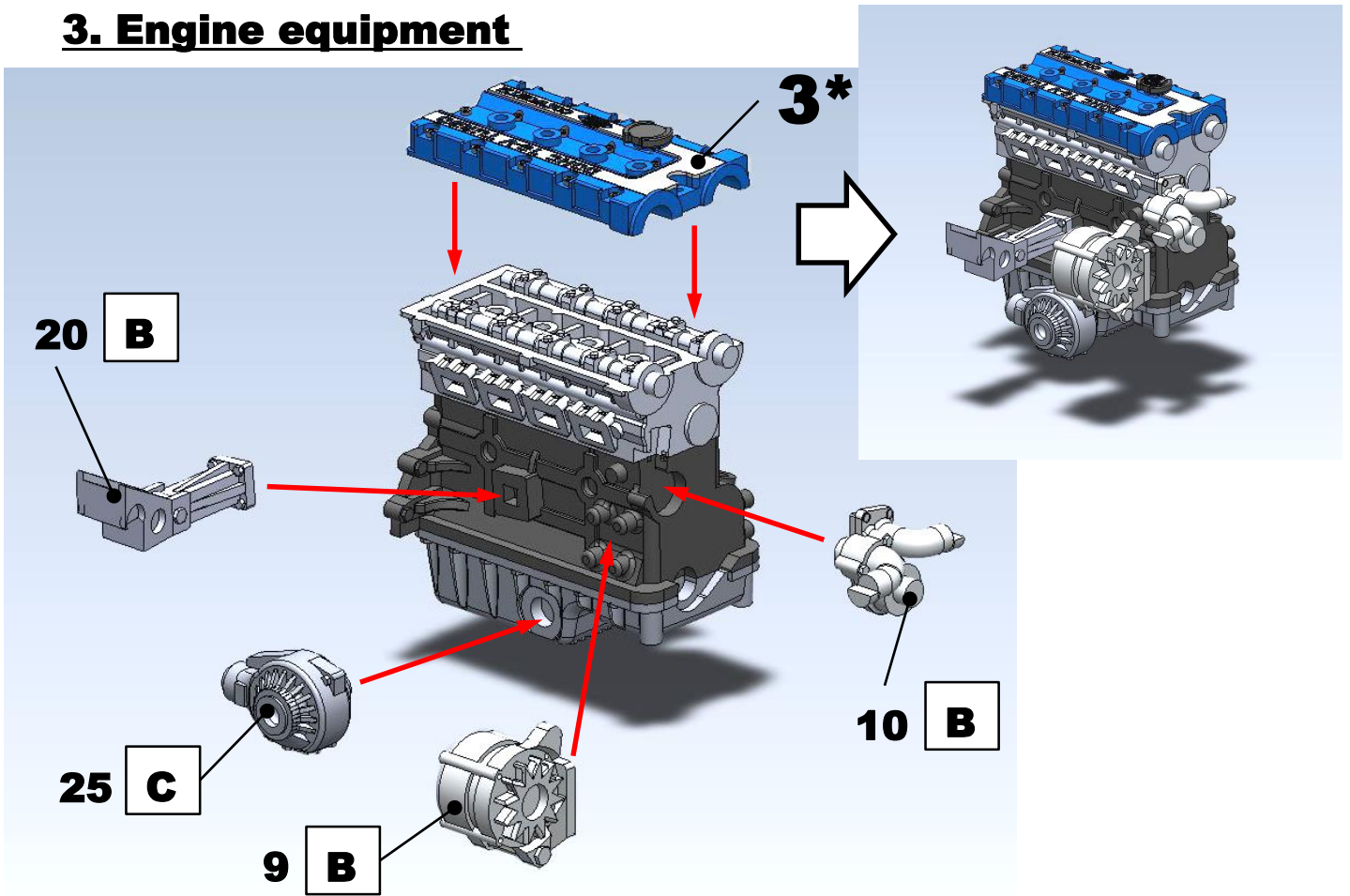

### 4. Engine equipment, clutch

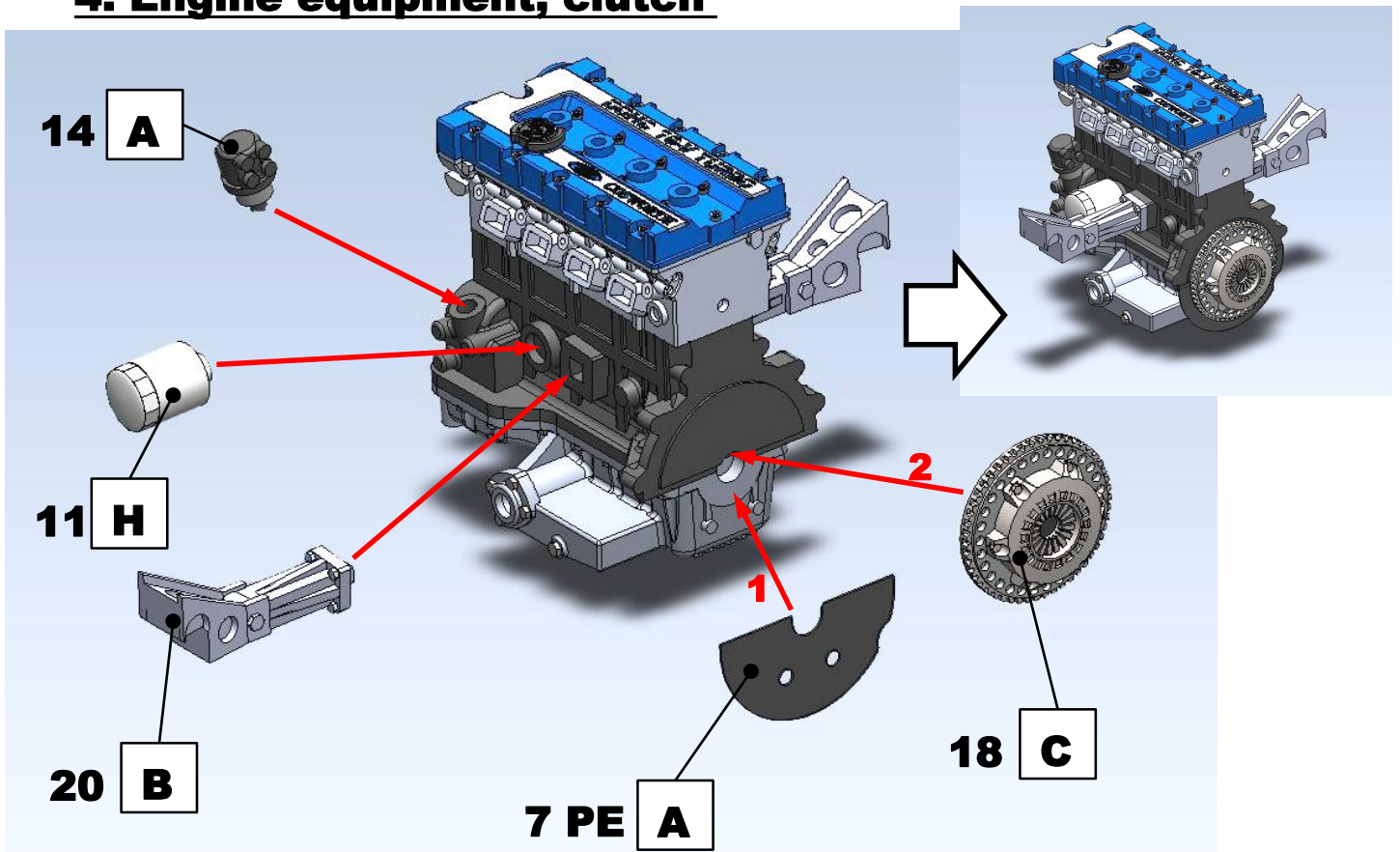

## 5. Intake, front cover

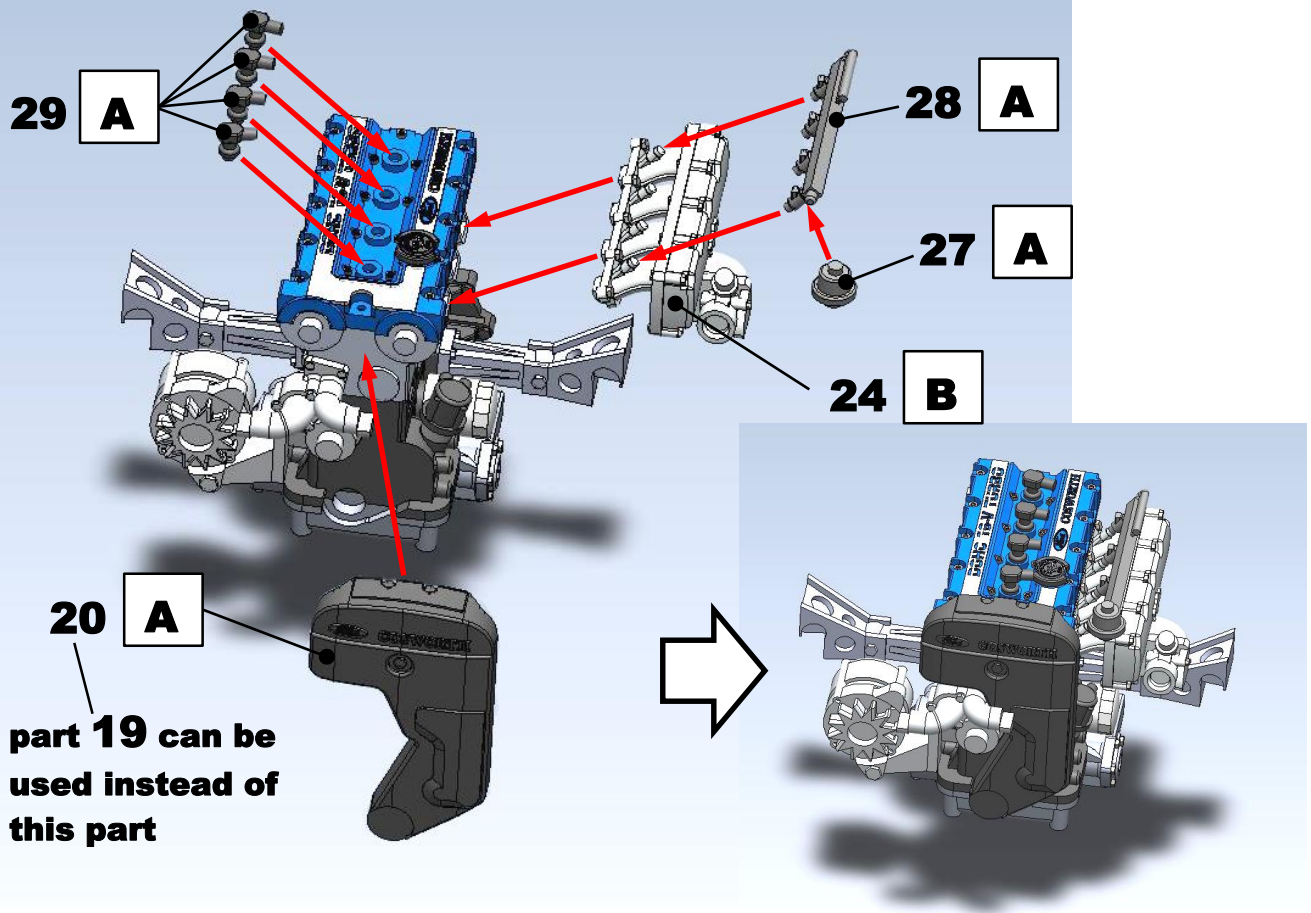

## 6. Exhaust turbo

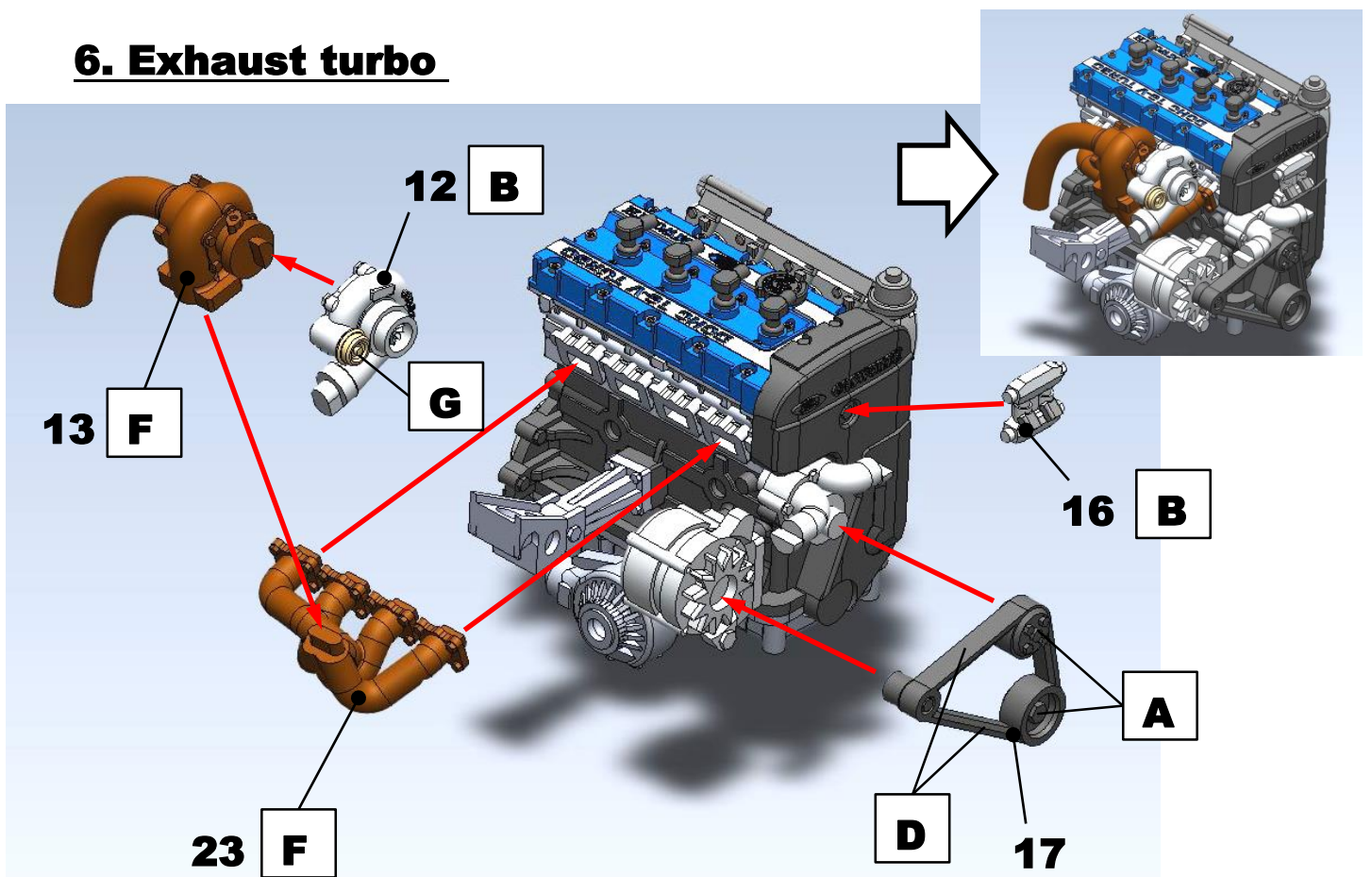

## 7. Gearbox

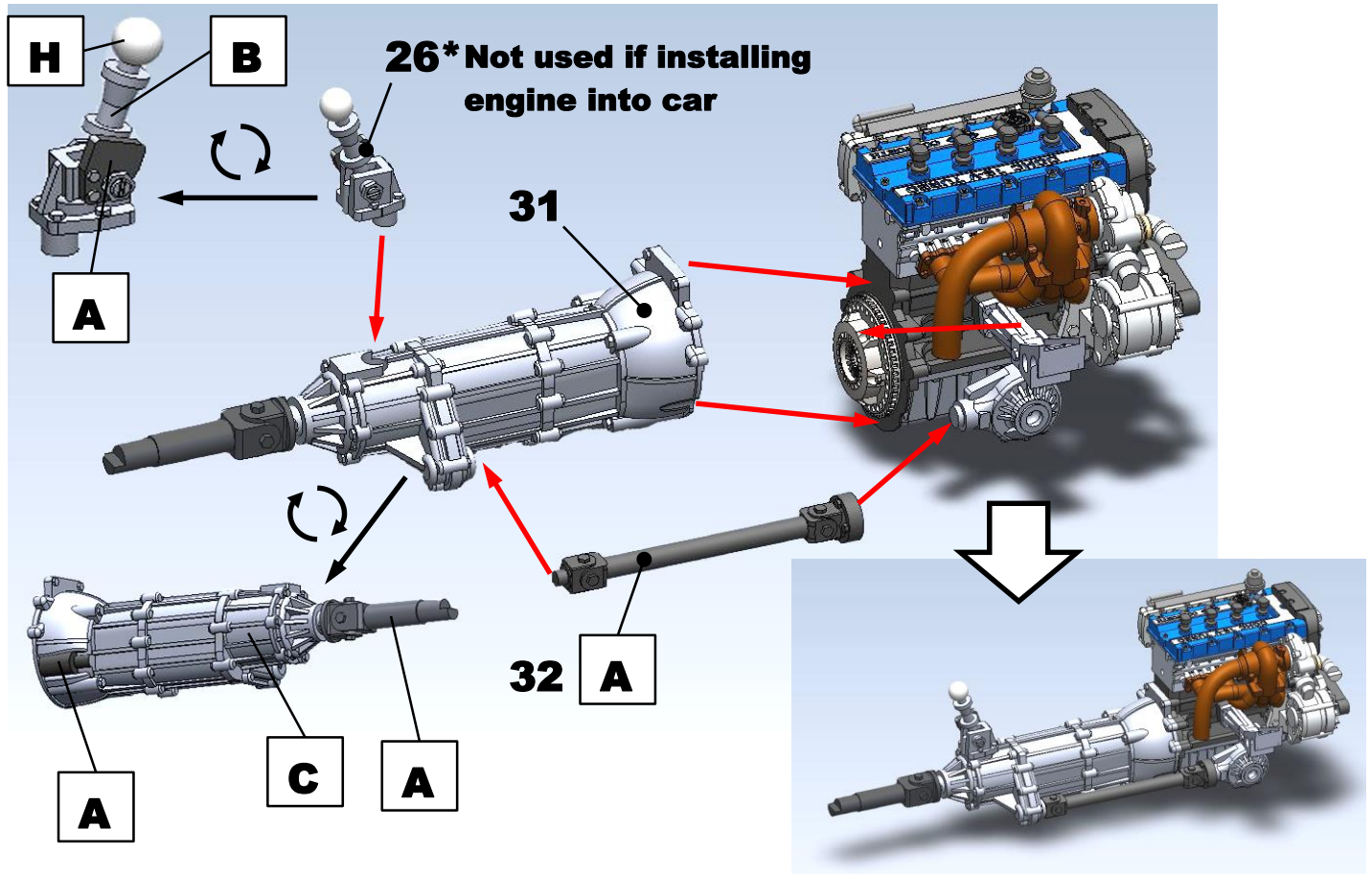

## 8. Kit chassis preparing

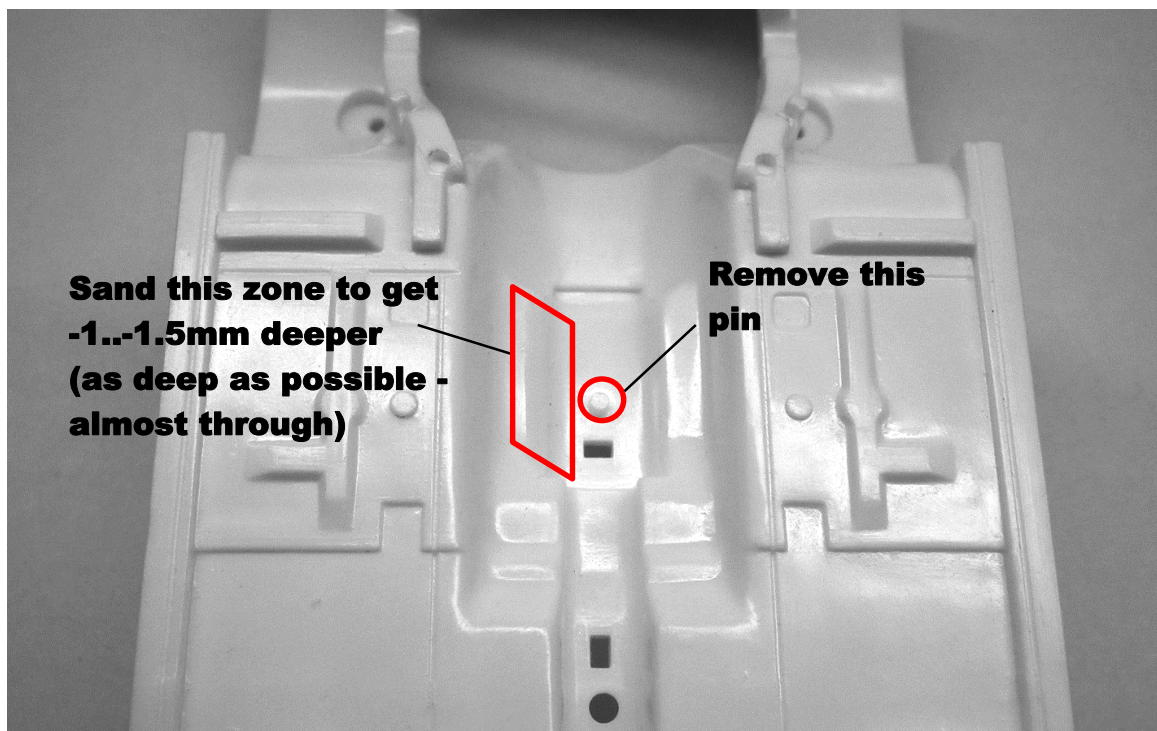

**After that install rear suspension parts**

## 9. Engine installation

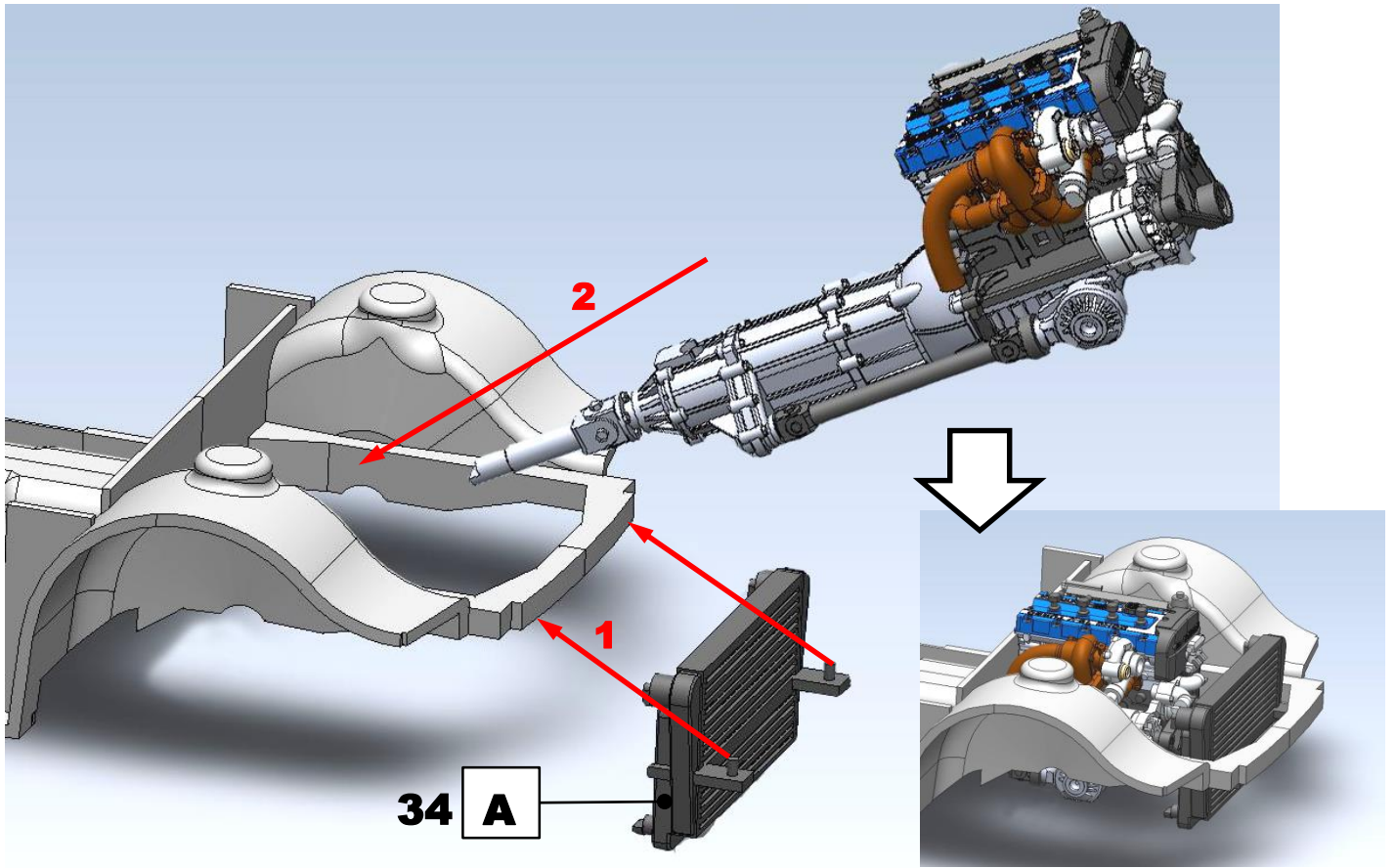

## 10. Front suspension

**First install front suspension parts**

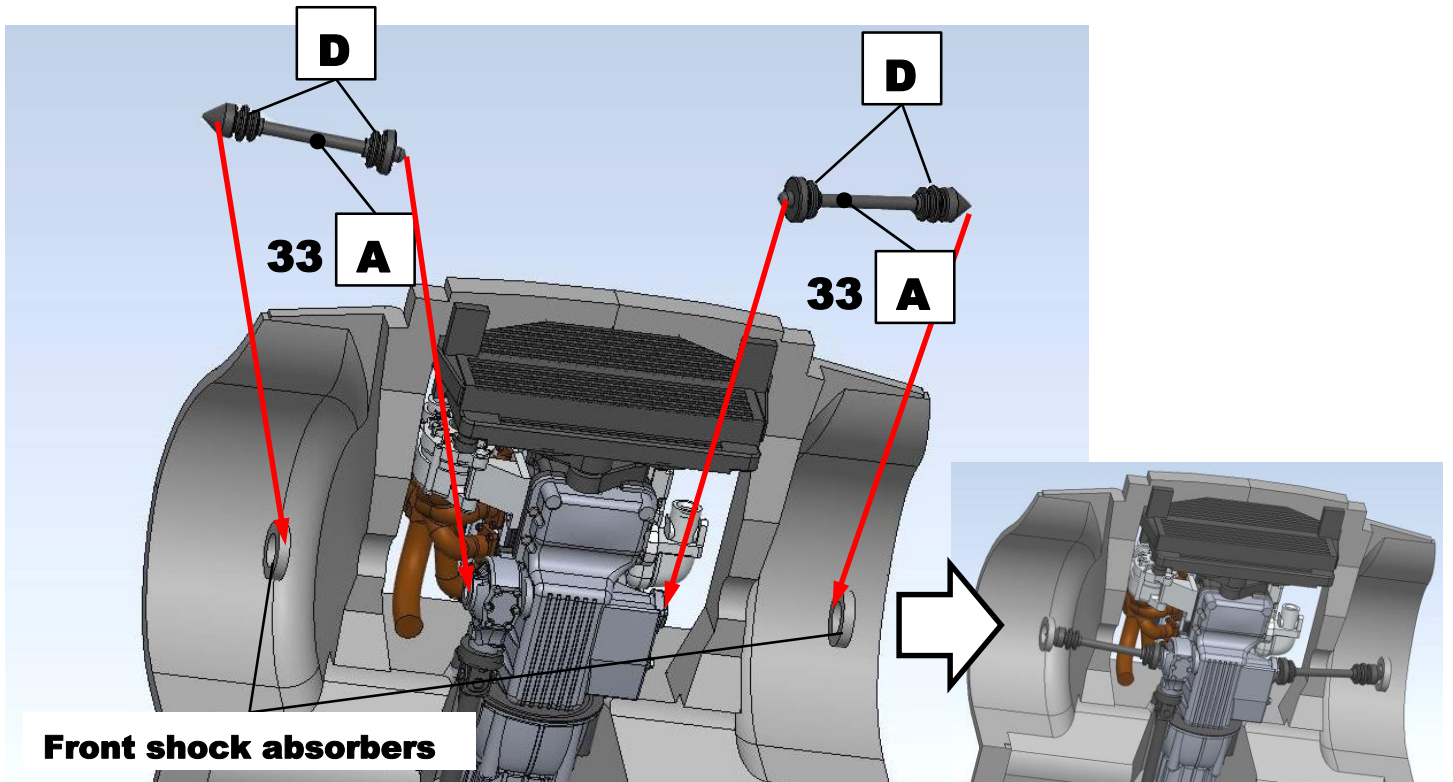

## 11. Coolant and air pipes

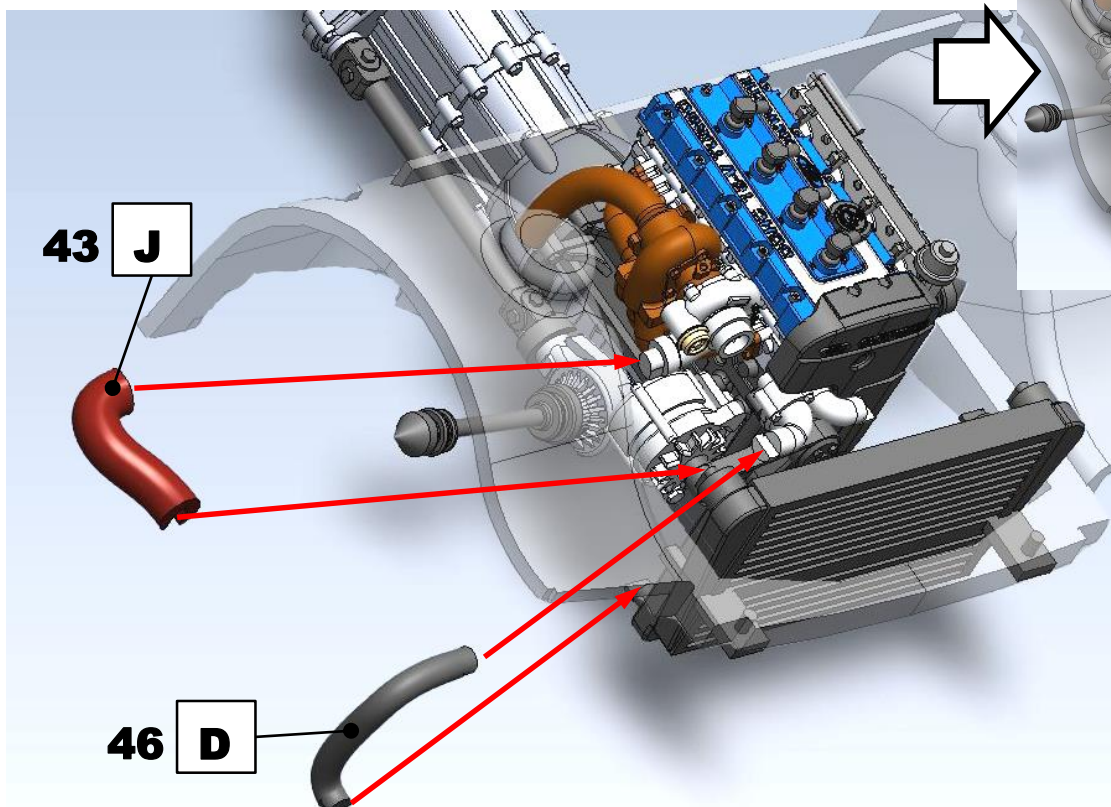

## 12. Coolant and air pipes

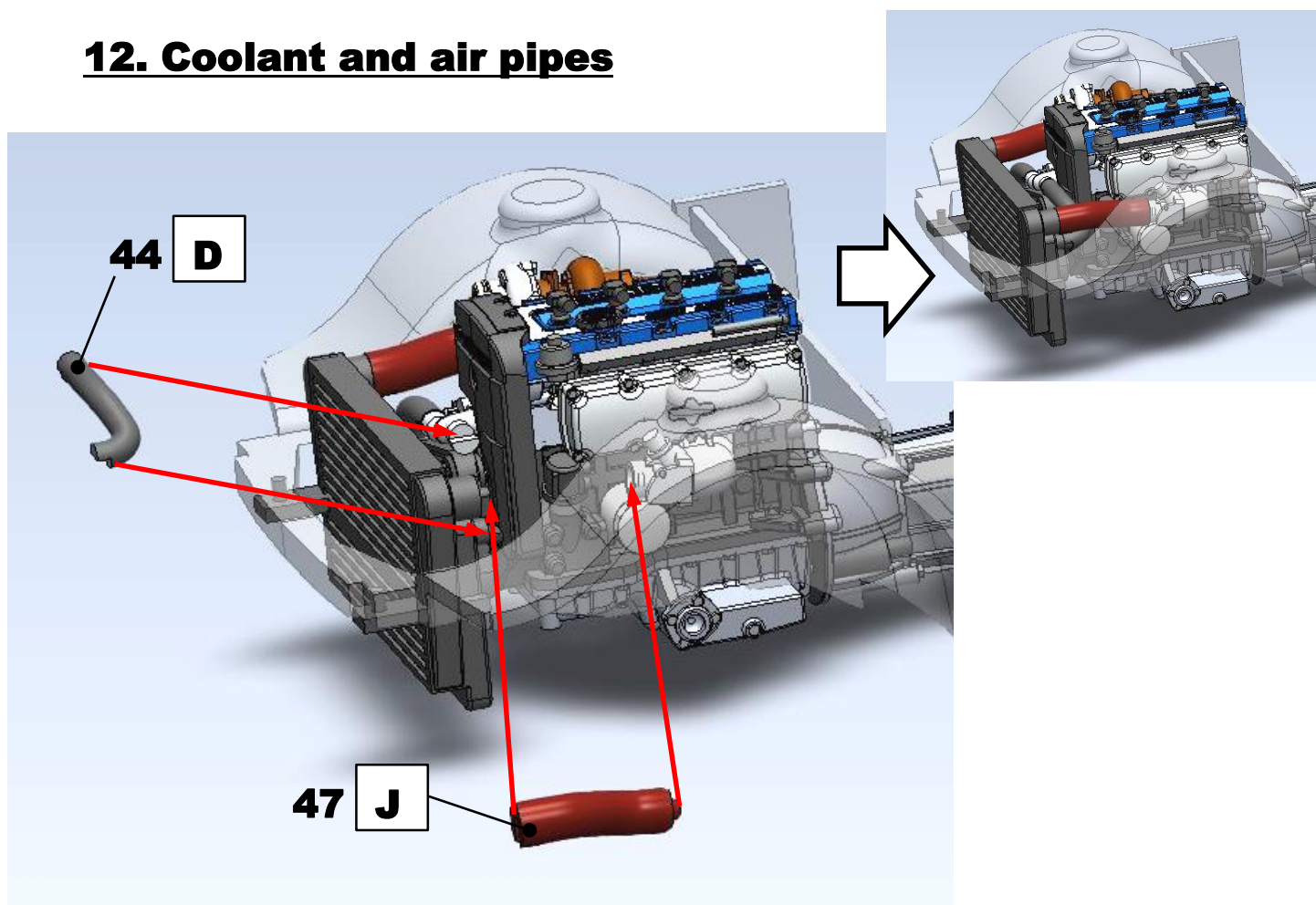



### 13. Engine bay part installation

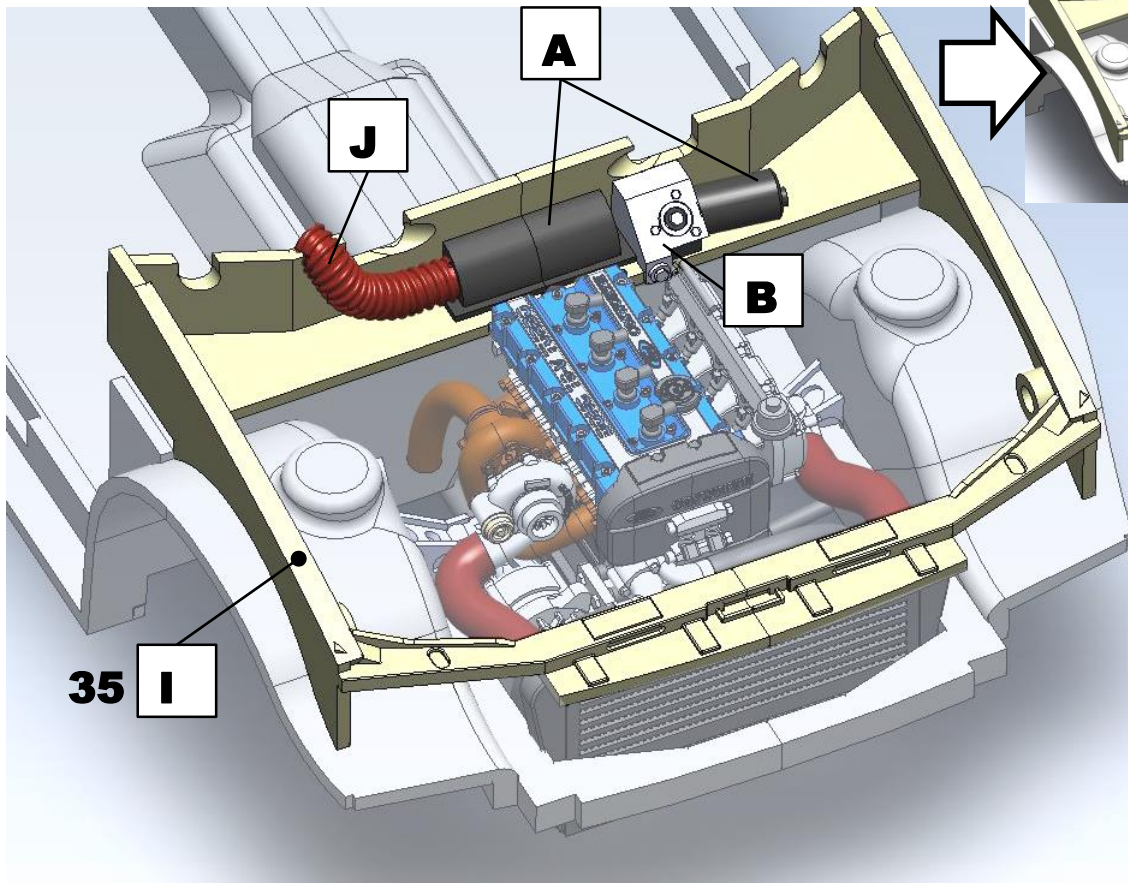

### 14. Engine bay parts

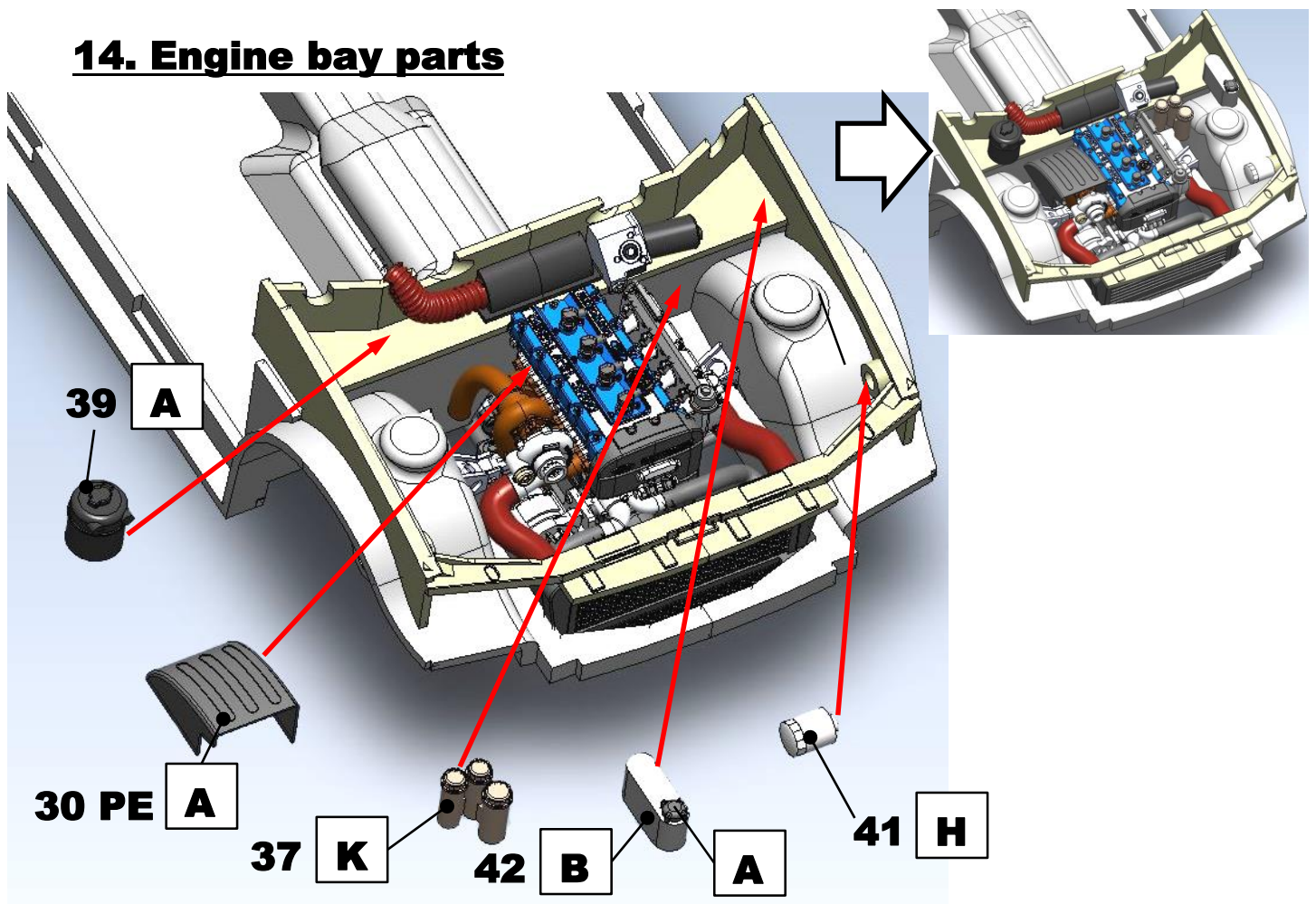

# 15. Engine bay parts

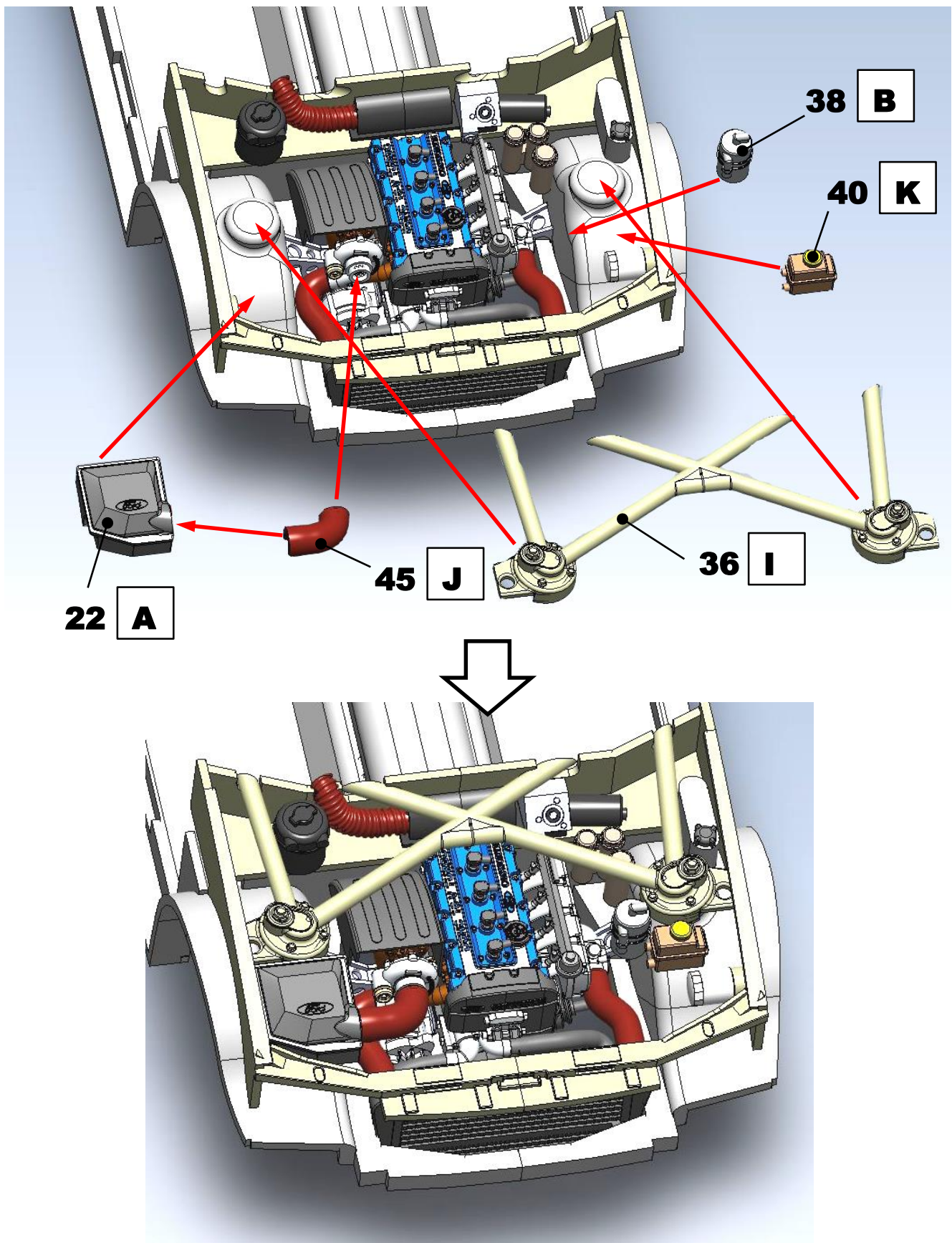

**Bonnet #48 must be used in place of bonnet from kit**

**To fit door cards with resin engine you will need to cut square area in a front of it, like shown on the picture**

