



# GLORY

INSTALLATION INSTRUCTION **安装说明书**

永恒之星-光辉

ETERNAL STAR [ST-001]

SUPREME EVOLUTION ARMAMENTACTICAL SERIES

※ 图片为3D效果渲染图，与实际商品存在一定差距，请以实物模型为准。 The picture is a 3D effect rendering, there is a certain gap with the actual product, please refer to the real model.



# 组装 (使用) 说明

BASIC INFORMATION BEFORE ASSEMBLY

## 警告 WARNING

本品含有小零件, 请勿让三岁及以下儿童玩耍, 建议使用年龄为15岁以上。  
Small parts are included in this product. The product is designed for children over 15 and is forbidden for those under 3.

## 注意事项 MATTERS NEED ATTENTION

清洁请使用干布抹擦干净, 对拆除后的包装物, 请不要随意丢弃以污染环境卫生。

Cleaning it with a dry cloth. Don't litter away any wrapping materials after removing them to protect environment.

## 水贴贴法 WATER STICKER METHOD

- ① 用剪刀或笔刀连带底纸剪下水贴。  
Use scissors or a pen knife and the backing paper to cut the drainer.
- ② 请把水贴在冷水或温水表面放置10秒左右之后用镊子小心捞出。  
Please put the water sticker on the surface of cold or warm water for about 10 seconds and carefully remove it with tweezers.
- ③ 从底纸上轻轻掀开水贴, 边调整位置边贴到合适位置。  
Gently lift the water sticker from the bottom paper, and adjust the position while pasting to the appropriate position.
- ④ 用棉签轻轻挤压已贴好的水贴并挤出多余水分, 等干透完成。  
Gently squeeze the water sticker with a cotton swab and extrude excess water, and wait until dry.

※ 细小的零件和贴纸容易损坏或丢失, 请充分注意。使用镊子的话会更为方便。  
(本品不附带任何工具, 如有需要请另行准备。)

Small parts and stickers are easily damaged or lost, please pay full attention. It's easier to use tweezers. (This product does not come with any tools, please prepare separately if necessary.)

## ⚠ CAUTION / 注意事项

- ◆ 不适合15岁以下儿童使用;
- ◆ 组装前请详细阅读说明书;
- ◆ 请将零件按编号整齐组装, 组装后把边角料丢弃;
- ◆ 零配件当中有带尖锐或刺手的, 在组装时请小心;
- ◆ 请在成人指导下正确使用;
- ◆ 建议在涂装粘糊时使用安全的“水性涂料”;
- ◆ 含有细小零件, 请勿吞食, 以免造成窒息;
- ◆ 内有尖端物, 小心使用请勿刺人, 以免造成伤害;
- ◆ 为免产生窒息或其他之危险, 请将盒内袋装销毁。

- ◆ Only for children over 15 years old.
- ◆ Please read the instructions carefully before assembling.
- ◆ Please assemble the parts according to serial number and discard the leftover materials after assembling.
- ◆ Please be careful for any sharp parts when assembling
- ◆ Please use it properly under the guidance of an adult.
- ◆ It is recommended to use safe "water-based paint" when assembling and gluing parts.
- ◆ To avoid any potential risks of suffocation, please don't swallow any small parts contained in the product.
- ◆ To avoid causing injury , please be careful and don't use sharp parts to stab people.
- ◆ To avoid any potential risks like suffocation, please destroy the plastic bags in the box as soon as possible

- 请勿弯折或拉伸本产品内的零件
- 切勿将产品放在高温或强光照射环境下。

- Do not bend or stretch the parts in this product
- Do not place the product in a high temperature or strong light environment.

## 记号说明 SYMBOLS USED IN INSTRUCTIONS

 需要专用胶水贴 Use special plastic glue to paste	 安装时注意贴纸编号 Note the sticker number when installing	 按反方向安装部件 Parts installed on both sides	 贴花纸编号 Decal paper number	 两边安装相同部件 Install the same parts on both sides	 安装时注意方向 Note the direction when installing	 螺丝不要拧得过紧 Don't overtighten the screws
 需要剪掉的地方 Something that needs to be cut	 按号码顺序安装 Install in order of numbers	 按照数字数值组装 Assemble according to numeric values	 在后面进行组装 Assemble at the back	 先安装此部分 Install this section first	 选择其中之一安装 Something that needs to be cut	 用相同办法移动另一面 Move the other side in the same way

## 零件目录 PARTS LIST

※ 制作过程中透明零件可能存在气泡。There may be bubbles in the transparent parts during production.

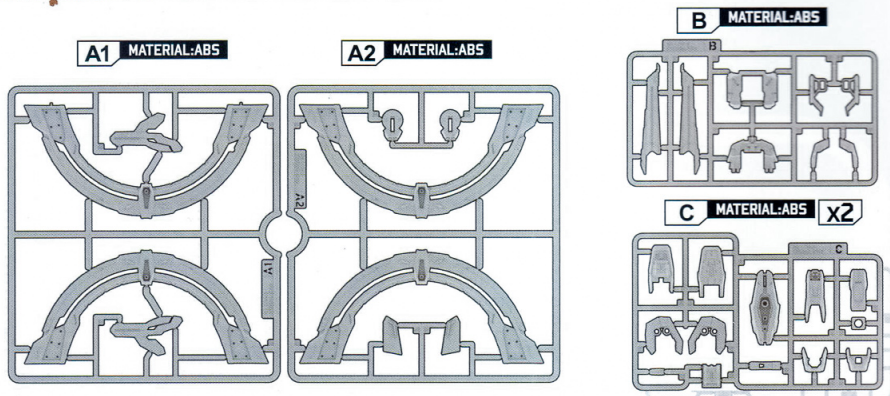

**D** MATERIAL:ABS

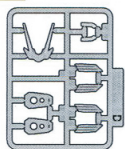

**E** MATERIAL:ABS

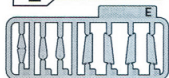

**F** MATERIAL:ABS

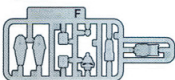

**G** MATERIAL:ABS

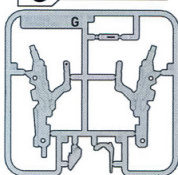

**H1** MATERIAL:ABS

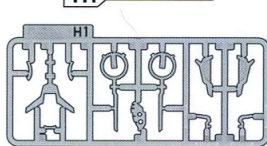

**H2** MATERIAL:ABS **x2**

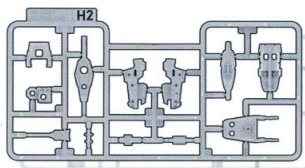

**H3** MATERIAL:ABS

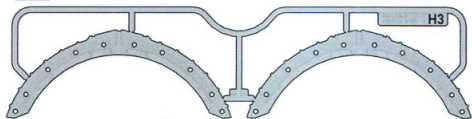

**I** MATERIAL:ABS **x2**

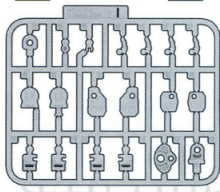

**J** MATERIAL:ABS

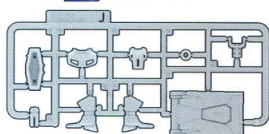

**K** MATERIAL:ABS **x2**

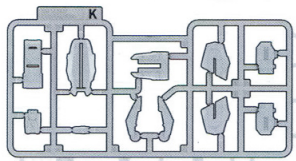

**L** MATERIAL:ABS **x2**

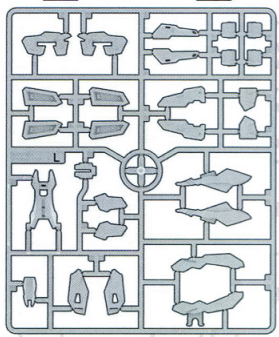

**N** MATERIAL:ABS **x2**

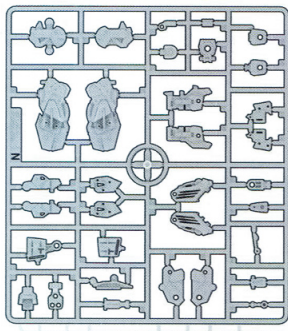

**M** MATERIAL:ABS

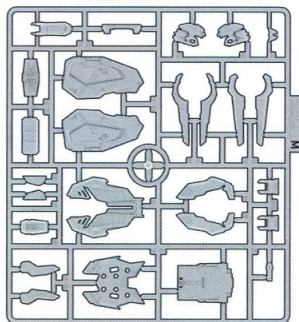

**O** MATERIAL:ABS

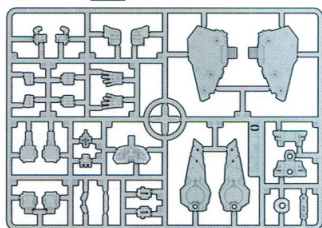

**P** MATERIAL:ABS

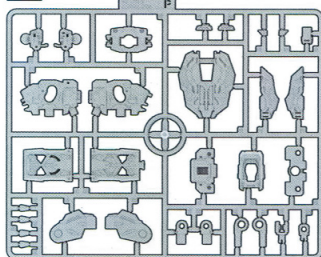

**PE** MATERIAL:ABS

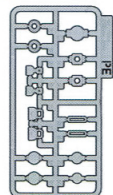



# 1 BOBY UNIT

身体组装

STEP

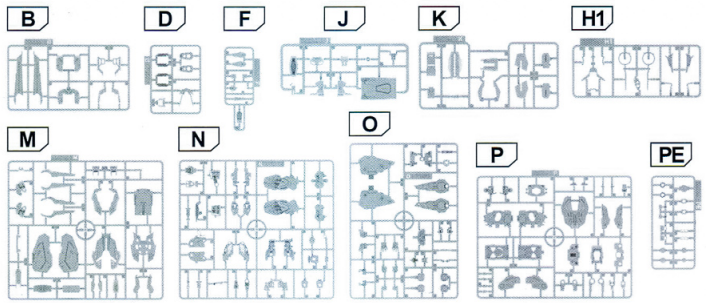

身体组装所需的板件编号

BOARD NUMBER REQUIRED FOR BODY ASSEMBLY

B D F H1 J K N M O P PE

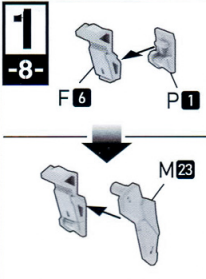
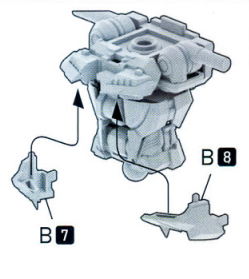
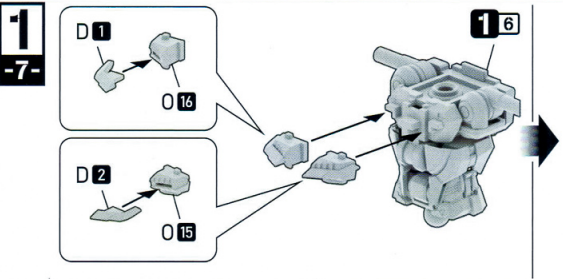
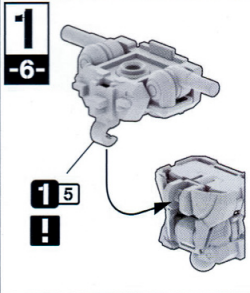
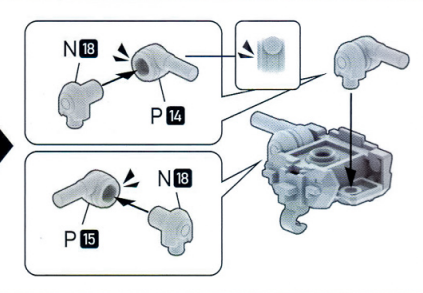
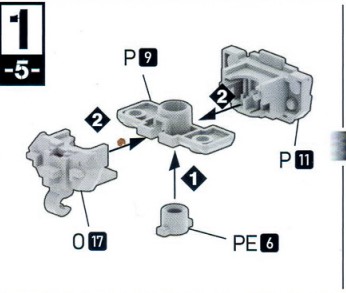
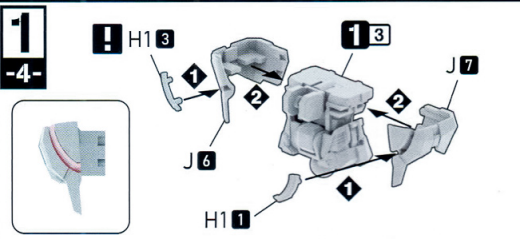
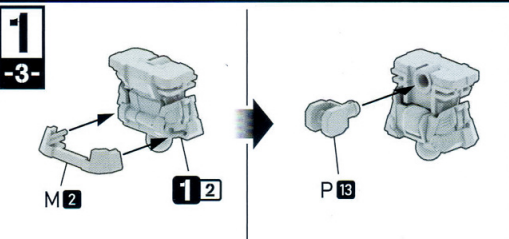
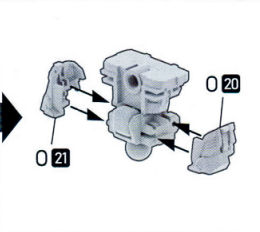
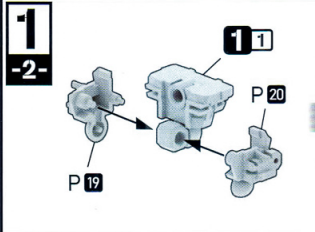
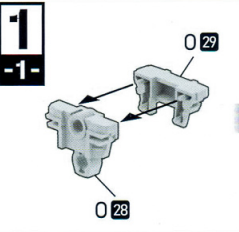



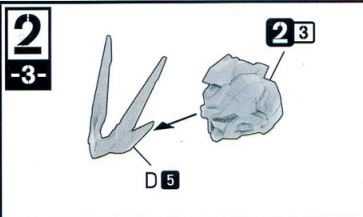
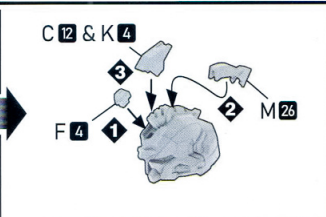
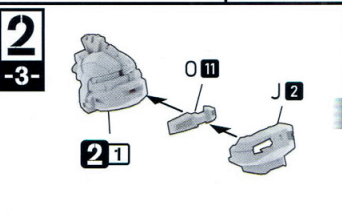
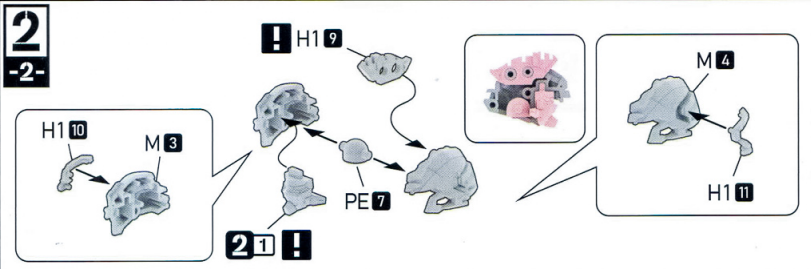
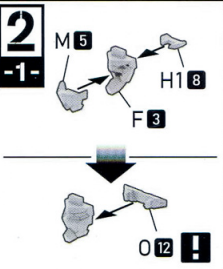
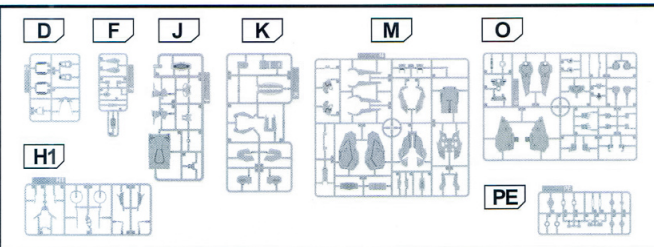
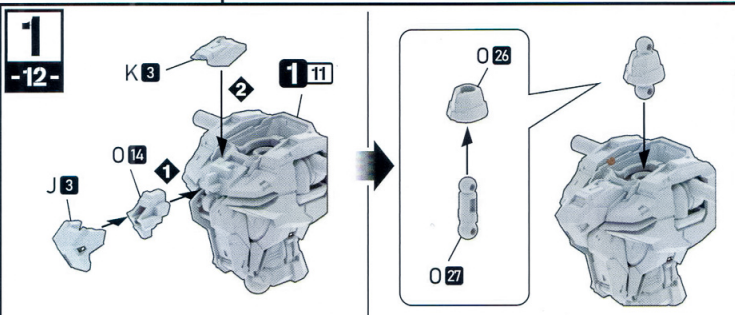
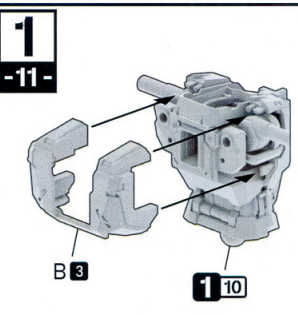
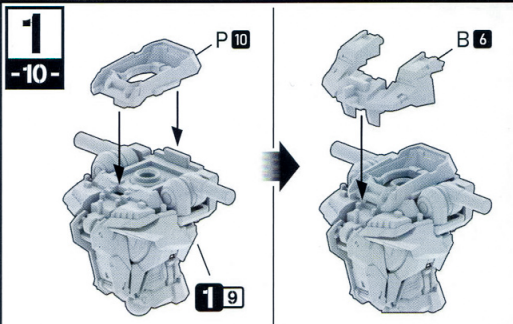
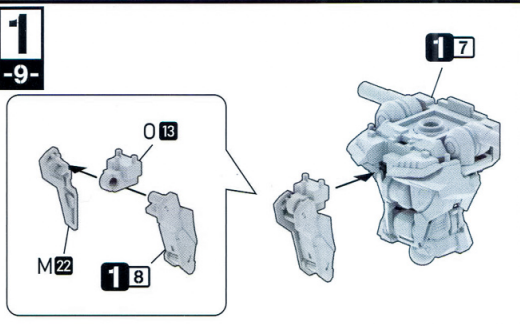

**1** • 按号码1.2.3...顺序安装  
• Assemble in unnumerical order 1.2.3...

**2** • 先安装此部分  
• Assemble this part first.

**3** • 两边安装相同部件  
• Both sides use identical parts.



# 3 STEP

## HIP UNIT

胯部组装

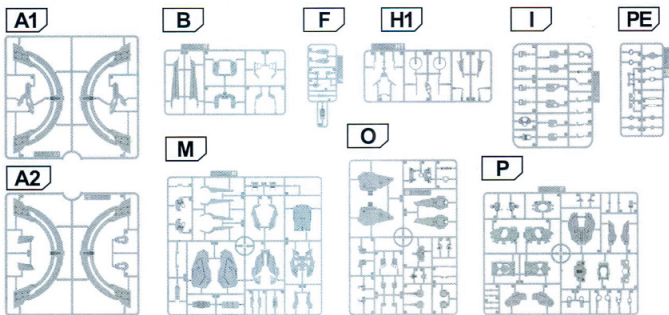
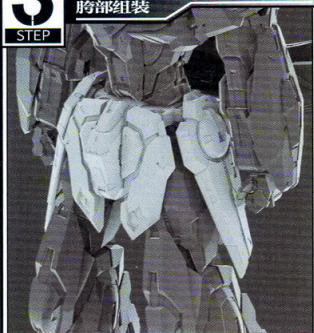

胯部组装所需的板件编号  
BOARD NUMBER REQUIRED FOR HIP ASSEMBLY

A1 B F H1 I M O P PE

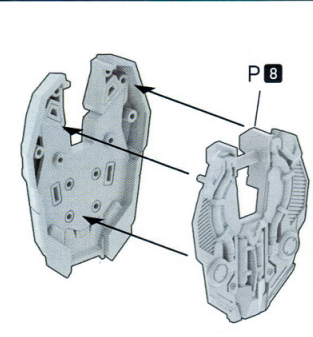
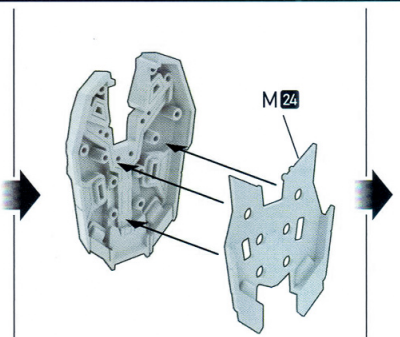
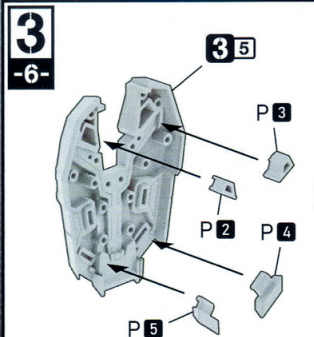
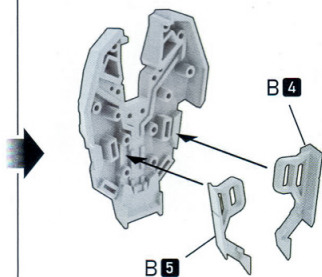
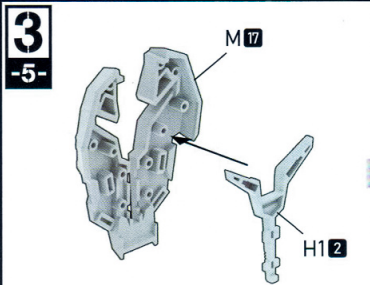
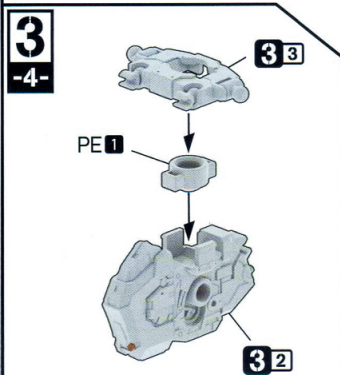
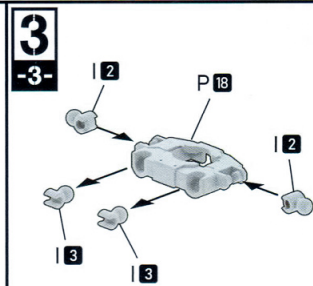
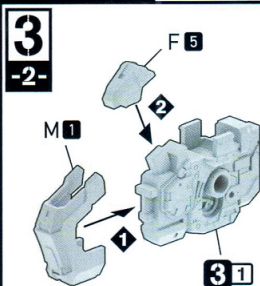
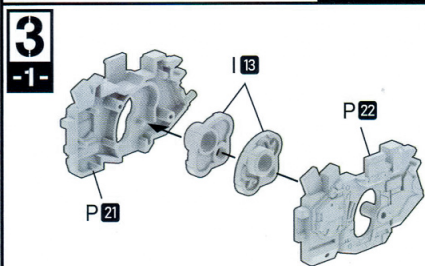



**3**  
-7-

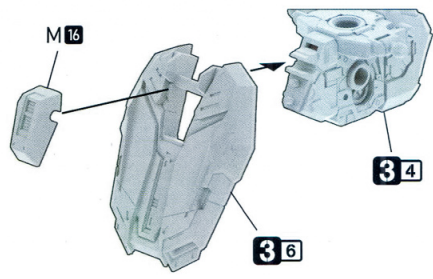

**3**  
-8-

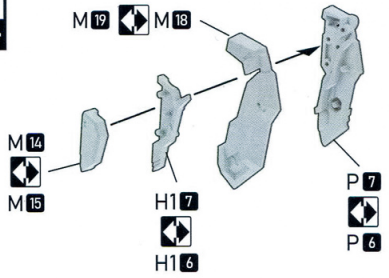

**3**  
-9-

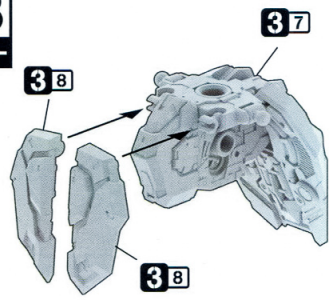

**3**  
-10-

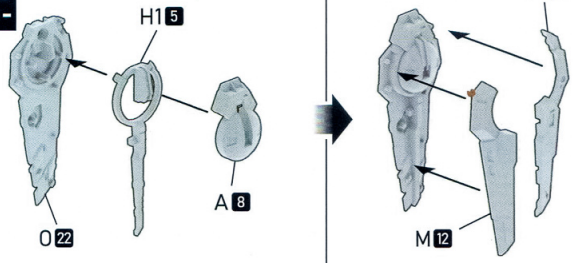

**3**  
-11-

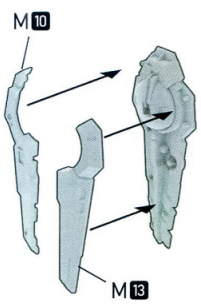
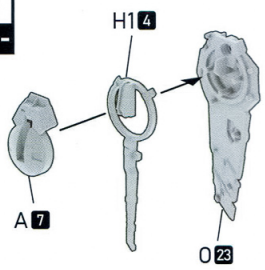

**1**  
-12-

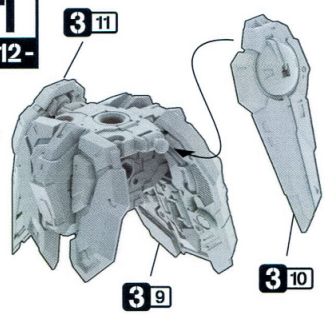

# 4 ARM UNIT

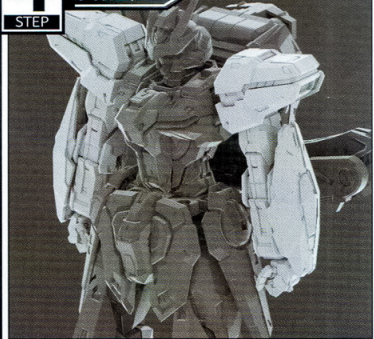

<b>C</b>	<b>F</b>	<b>K</b>	<b>H1</b>	<b>H2</b>
<b>I</b>	<b>L</b>	<b>N</b>	<b>O</b>	<b>PE</b>

身体组装所需的板件编号  
BOARD NUMBER REQUIRED FOR BODY ASSEMBLY

**C F K H1 H2 I L N O PE**

- 两边安装相同部件  
Both sides use identical parts.
- 按反方向安装部件  
Attach to the opposite side.



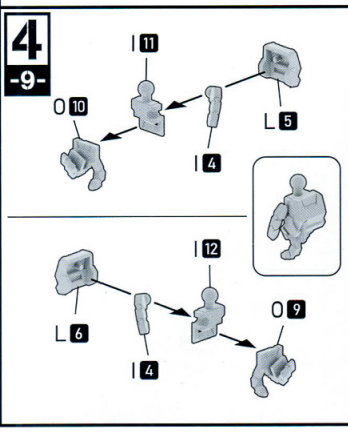
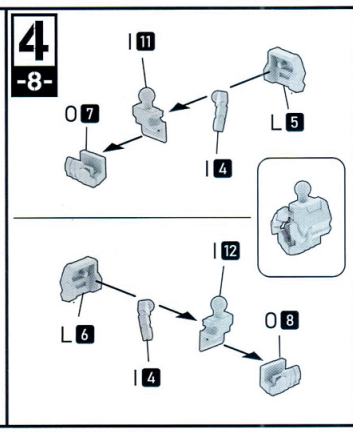
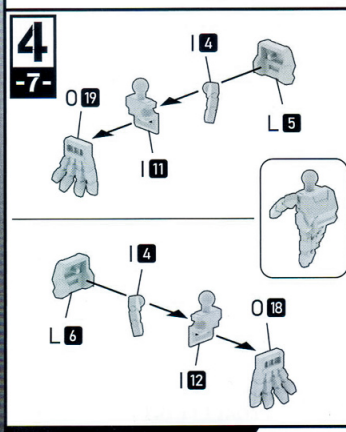
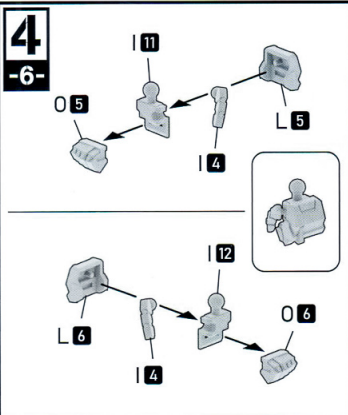
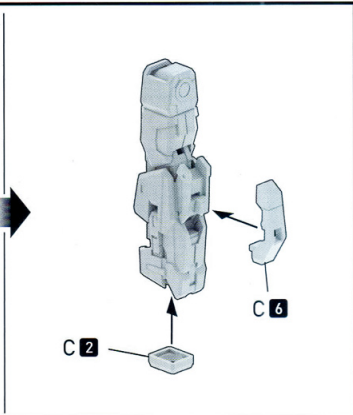
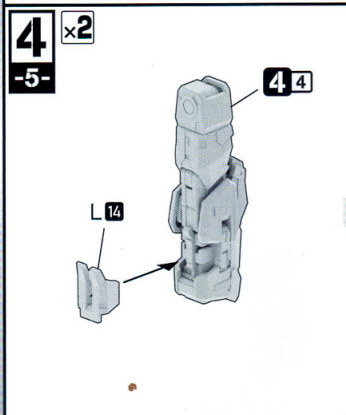
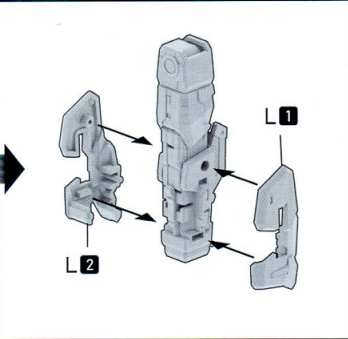
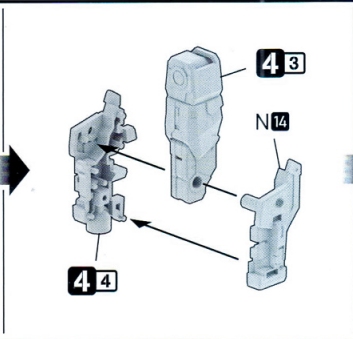
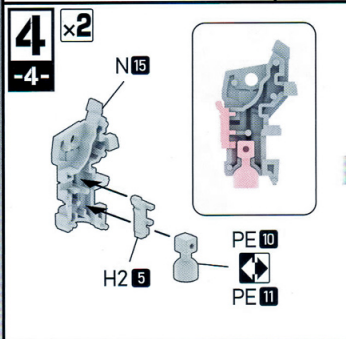
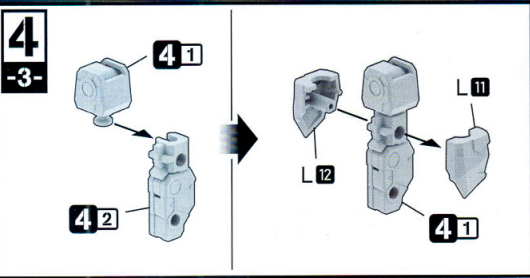
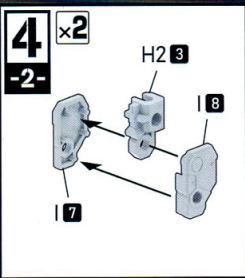
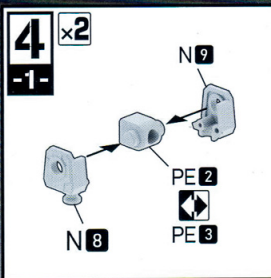



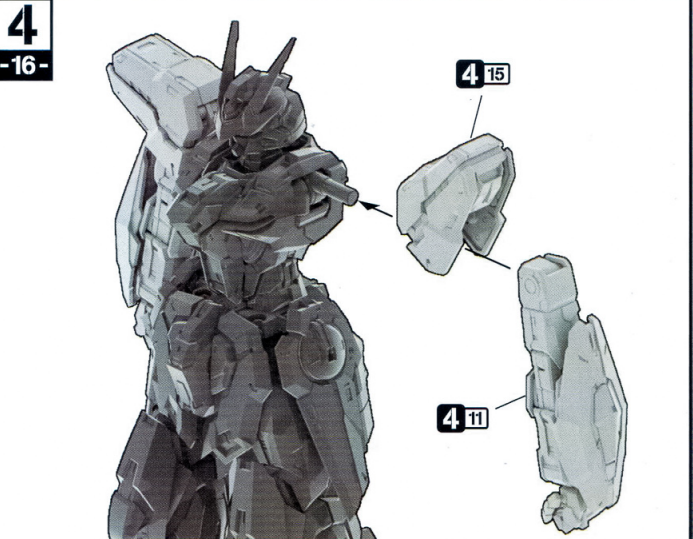
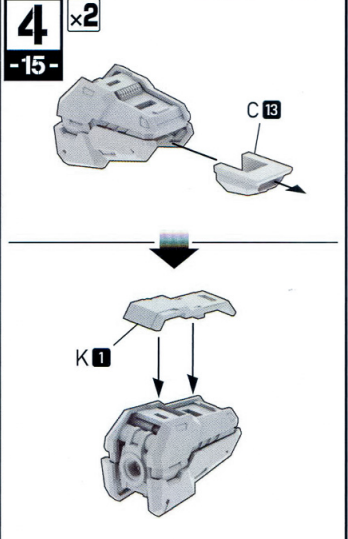
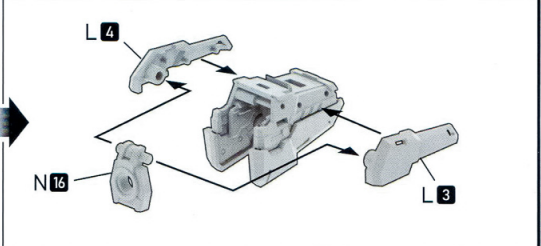
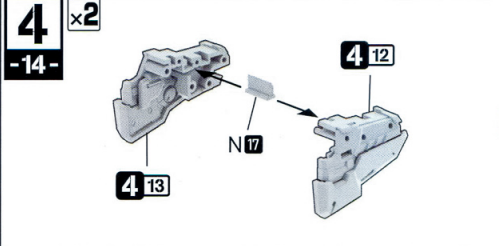
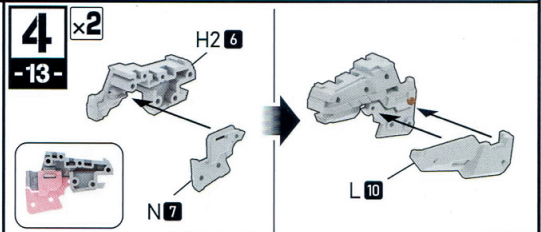
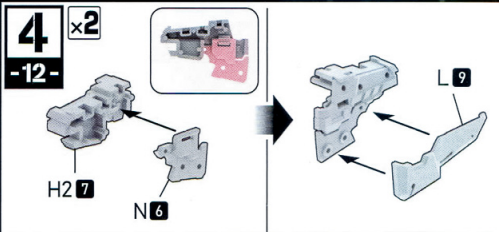
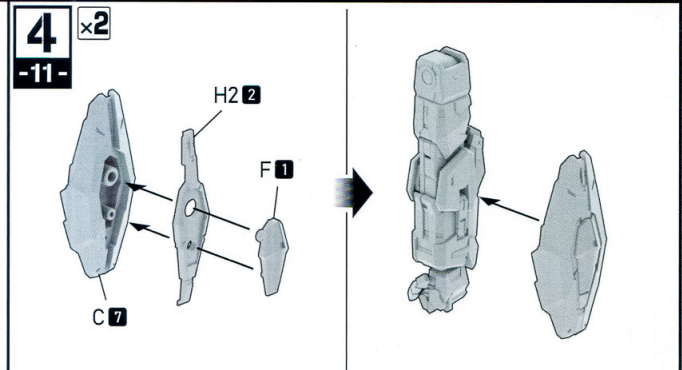
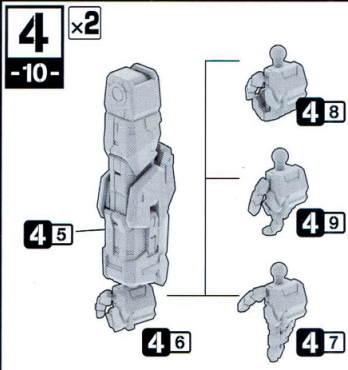

# 5 STEP

## LEG UNIT 腿部组装



Parts list for the leg unit assembly:

- C**, **D**, **F**, **H2**, **K**, **L**, **N**, **O**, **P**, **PE**

腿部组装所需的板件编号  
BOARD NUMBER REQUIRED FOR BODY ASSEMBLY

**5** x2

**-1-**

Parts: N5, 01, 02, 03, 04

**5** x2

**-2-**

Parts: N20, N22, N27, H2 8, PE 8, PE 9

Parts: N10, N11, N21, N1

**5** x2

**-3-**

Parts: 51, 52

**5** x2

**-4-**

Parts: K2, H2 11

Part: K5

**5** x2

**-5-**

Parts: L15, L16

Parts: N30, N31, PE 4, PE 5, PE 14, PE 15

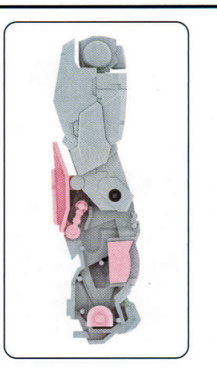



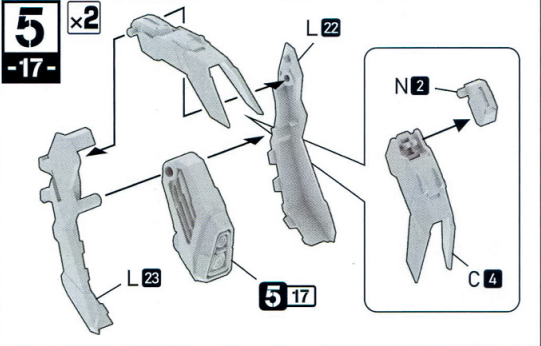
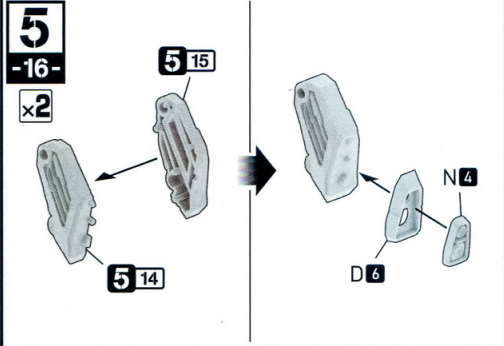
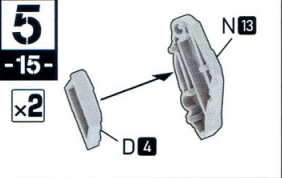
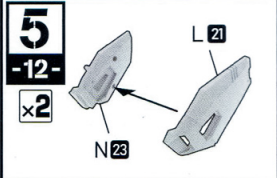
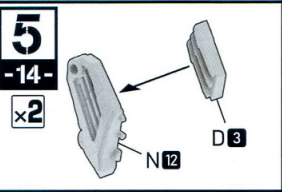
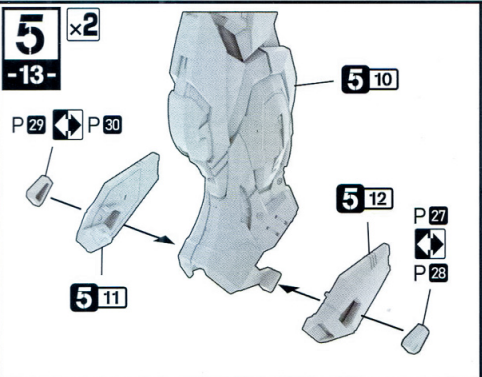
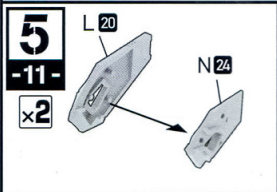
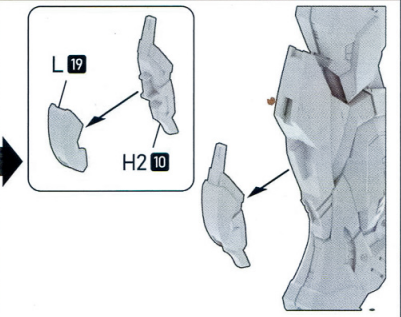
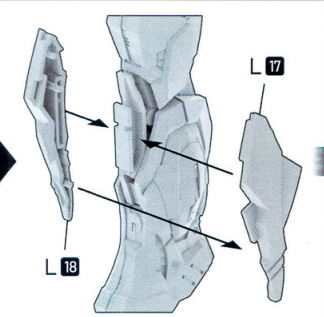
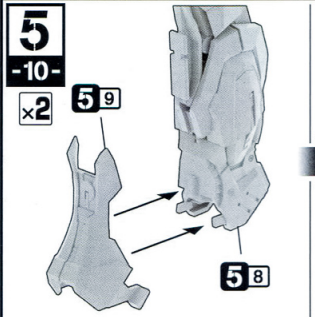
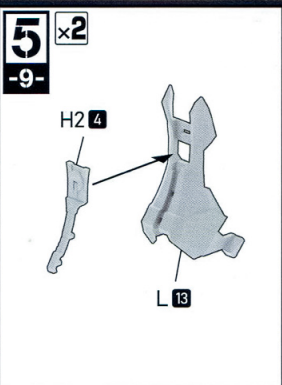
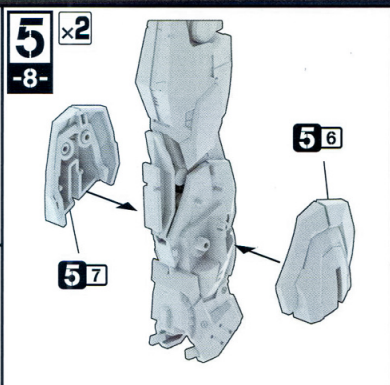
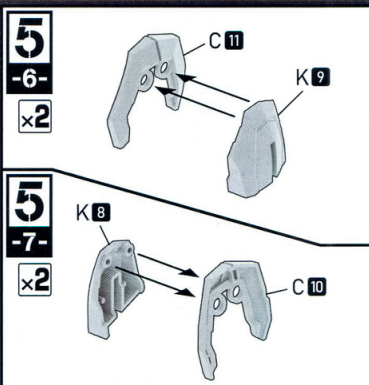

**1** • **◆** • **◆** 按号码1.2.3...顺序安装  
• Assemble in numerical order 1.2.3...

**x2** • 按照数字的数值组装部件  
• Build specified number of parts.

**◆** • 两边安装相同部件  
• Both sides use identical parts.

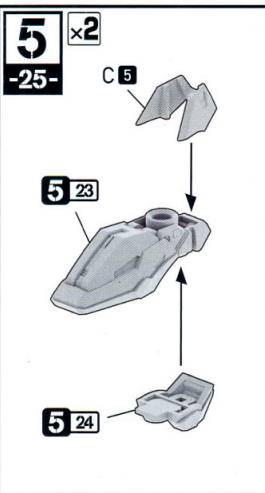
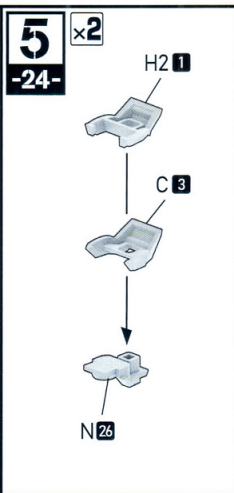
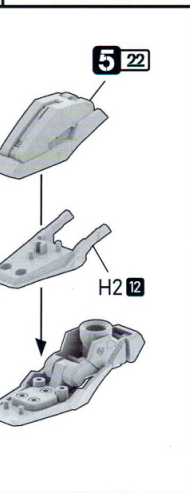
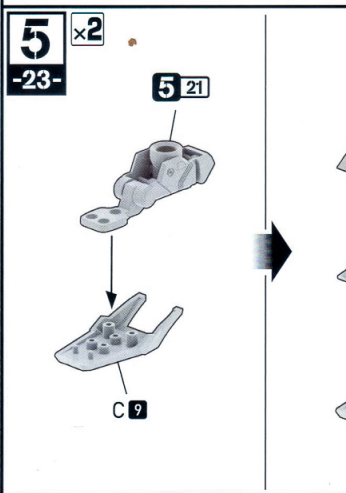
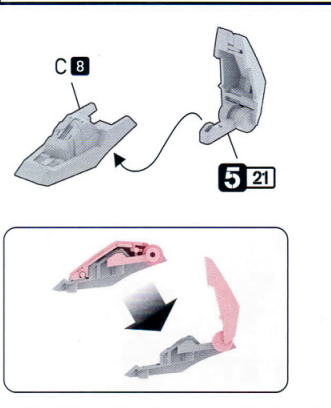
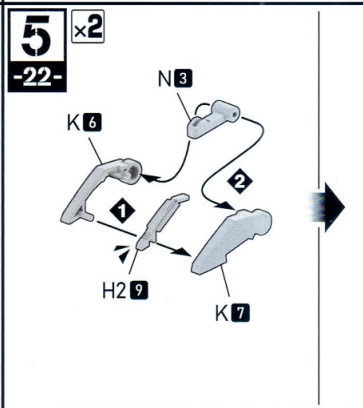
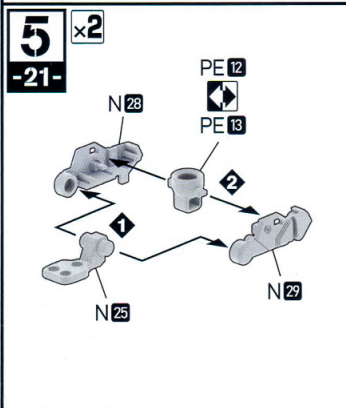
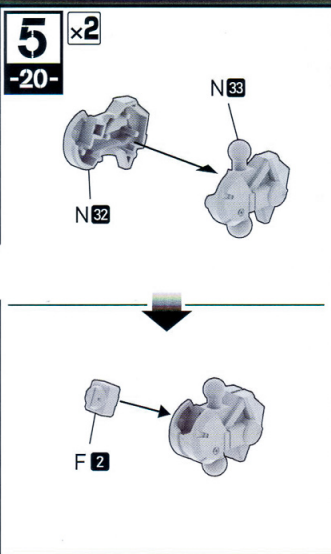
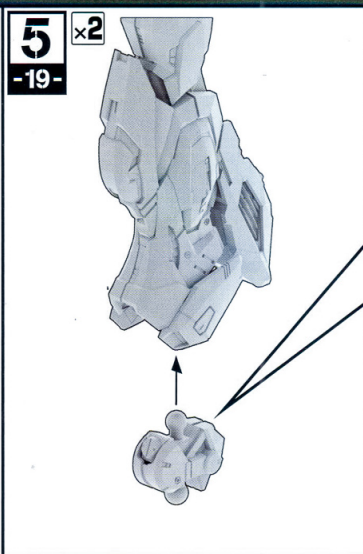
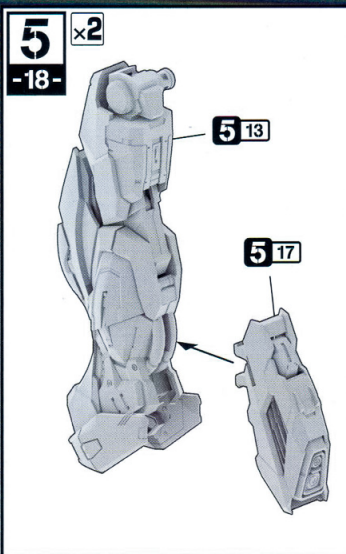



**5** x2  
-26-

**左腿/右腿组装**  
LEFT/RIGHT LEG ASSEMBLED

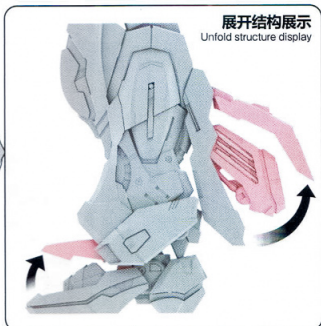
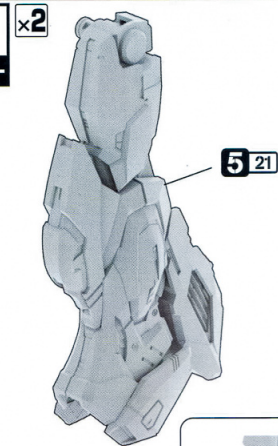

**5**  
-27-

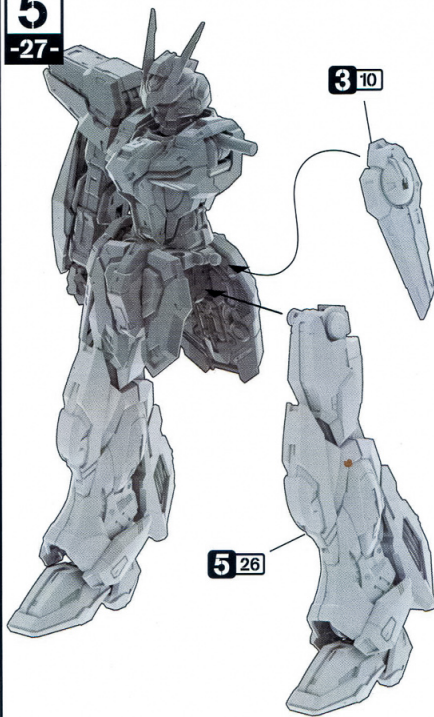

**6** PACK UNIT  
背包组装  
STEP



背包组装所需的板件编号  
BOARD NUMBER REQUIRED FOR BODY ASSEMBLY

**A1** **A2** **E** **F** **H2** **I** **J** **K** **L** **N** **M** **O** **P** **PE**

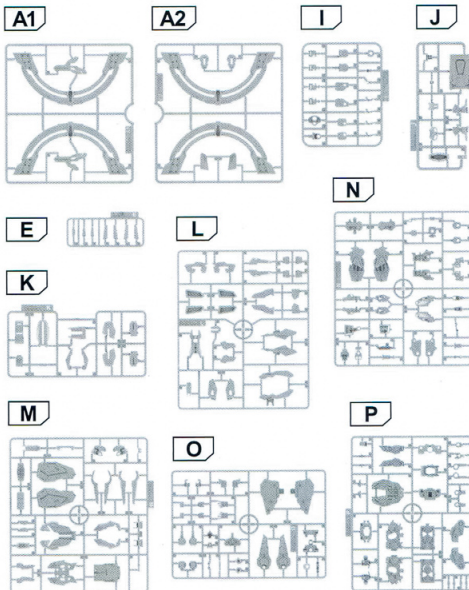

x2 • 按照数字的数值组装部件  
• Build specified number of parts.

• 两边安装相同部件  
• Both sides use identical parts.

! • 安装时注意方向  
• Pay attention to part orientation when assembling.

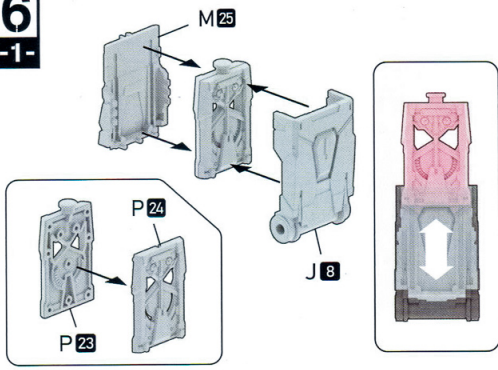
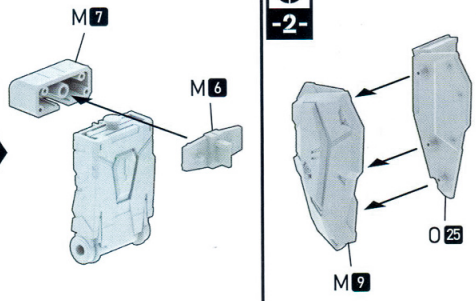
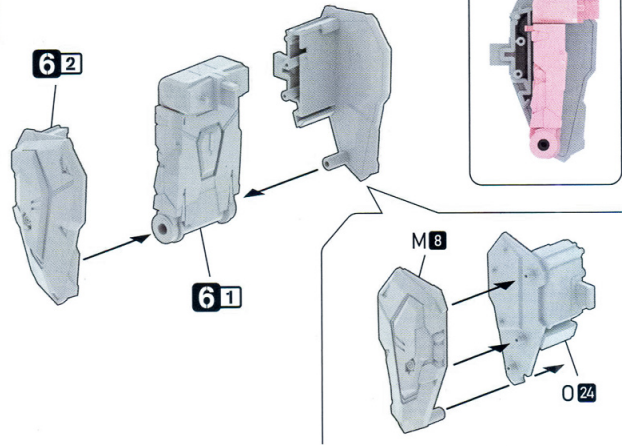
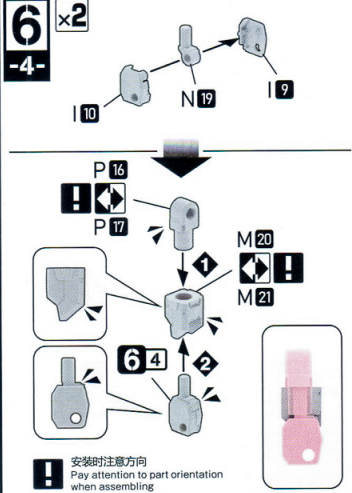
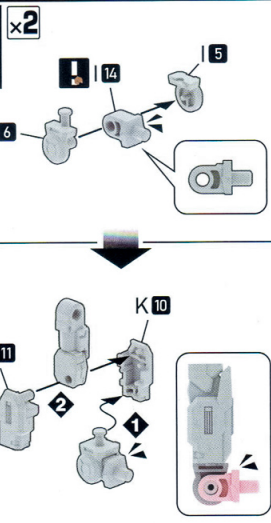
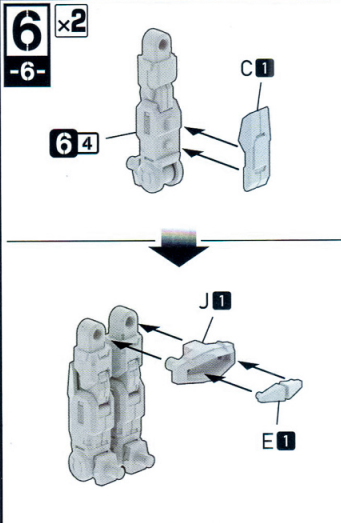
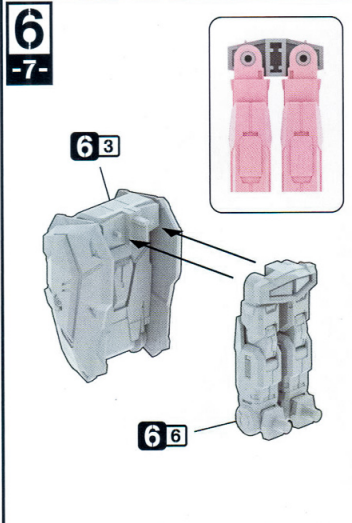
**6**  
**-1-****6**  
**-2-****6**  
**-3-****6**  
**-4-****6**  
**-5-****6**  
**-6-****6**  
**-7-**



**6**  
-8-

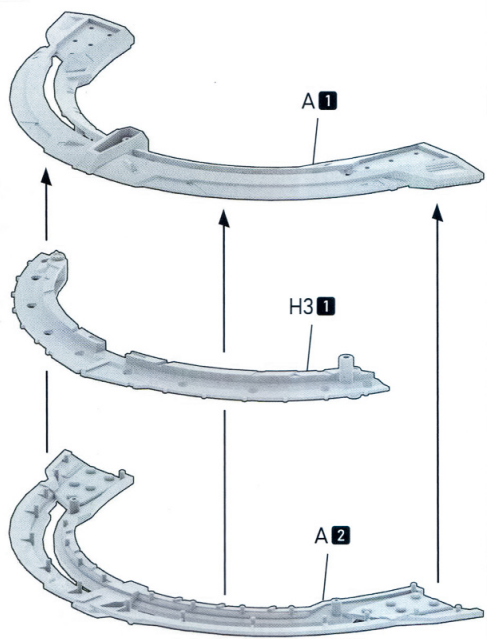

**6**  
-9-

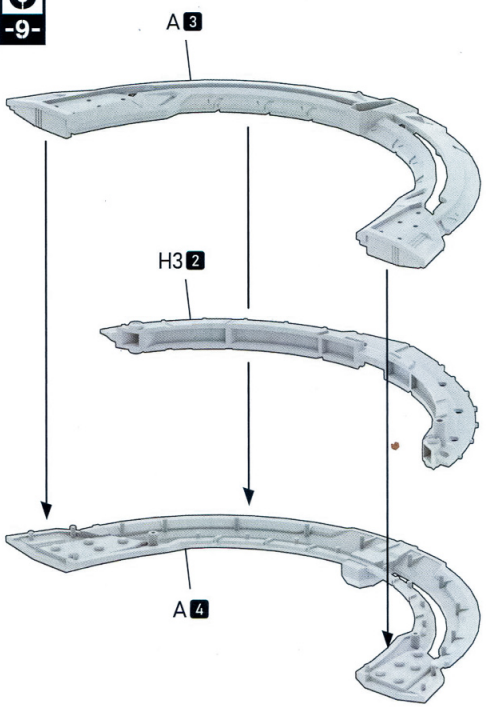

**6** x2  
-10-

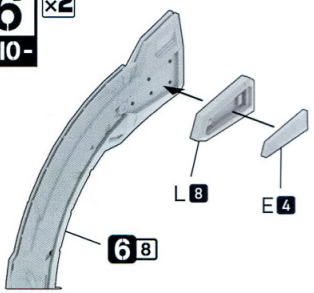

**6** x2  
-11-

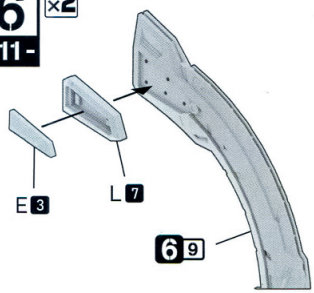

**6** x4  
-12-

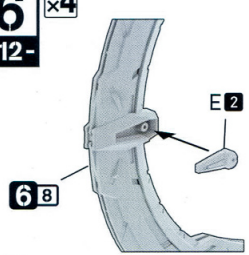

**⇄** 两边安装相同部件  
Both sides use identical parts

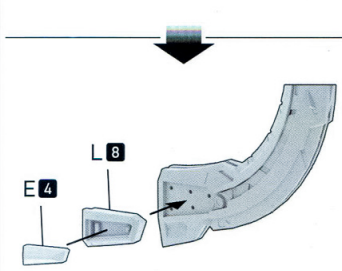
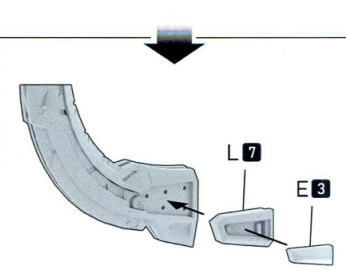

**6** x2  
-13-

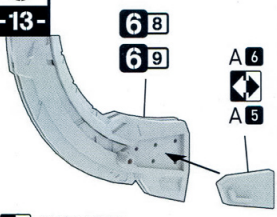

**↻** 按反方向安装部件  
Attach to the poopsite side

**x2** • 按照数字的数值组装部件  
• Build specified number of parts.

**⇄** • 两边安装相同部件  
• Both sides use identical parts.

**H** • 安装时注意方向  
• Pay attention to part orientation when assembling.

**6**  
-14-

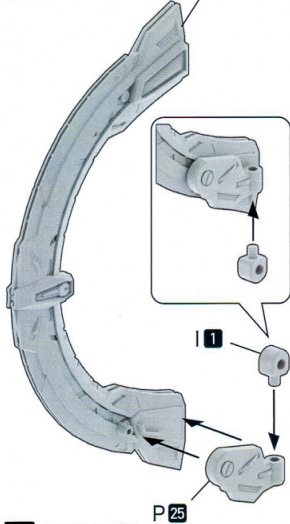

**!** 上下孔位均可装配  
Both upper and lower holes can be assembled

**6**  
-15-

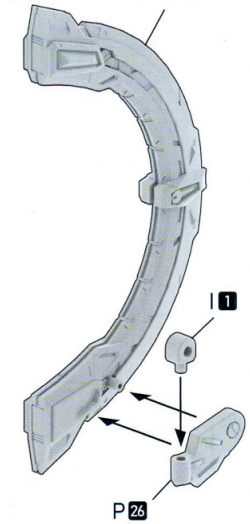

**6**  
-16-

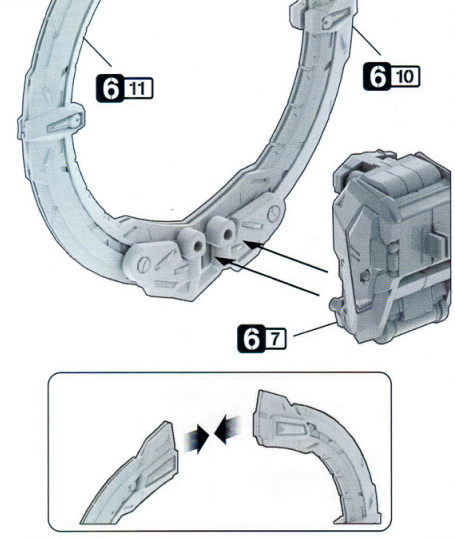

**5** 27

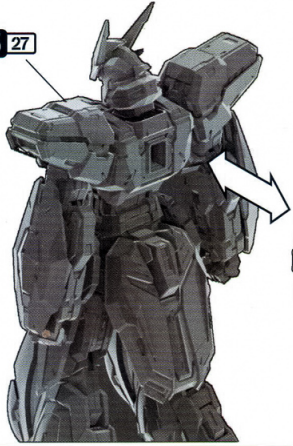

**6** 16

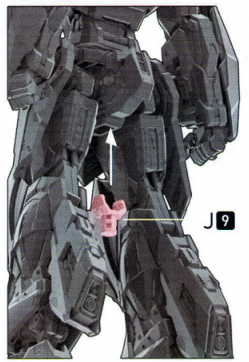
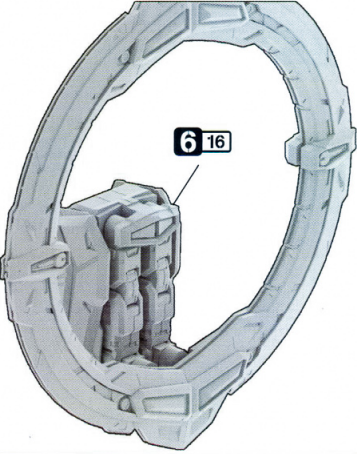

**!** 支架连接件，适用于4mm接口支架  
Bracket connector, suitable for 4mm interface bracket

**7**  
STEP

**BOBY UNIT**  
身体组装

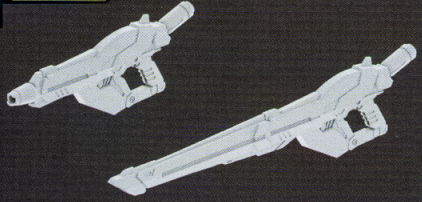

**A1**

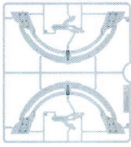

**A2**

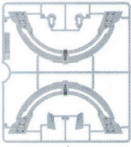

**B**

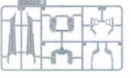

**G**



**J**



身体组装所需的板件编号  
BOARD NUMBER REQUIRED FOR BODY ASSEMBLY

**A1 A2 B G J**

**15**

ETERNAL  
GLORY

**!** 安装时注意方向  
\* Pay attention to part orientation when assembling



**7**  
**-1-**

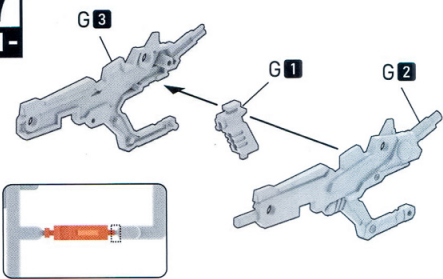

**!** 剪下G-1零件时需注意，勿将装配位当水口切除  
When cutting G-1 parts, be careful not to cut the assembly position as the water outlet

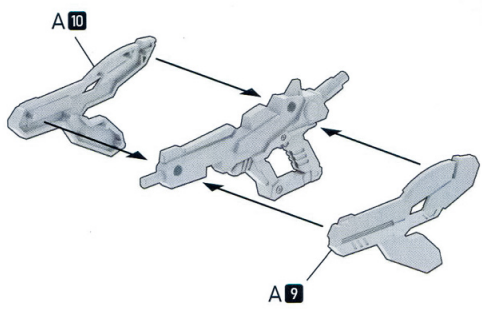

**7**  
**-2-**

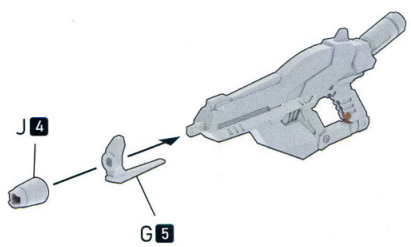
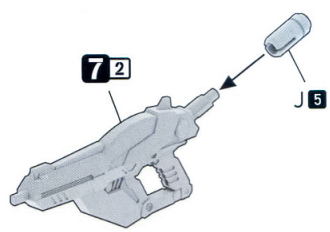

**7**  
**-3-**

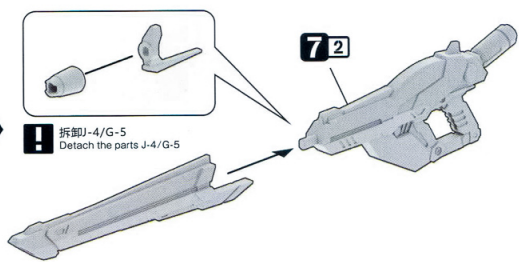
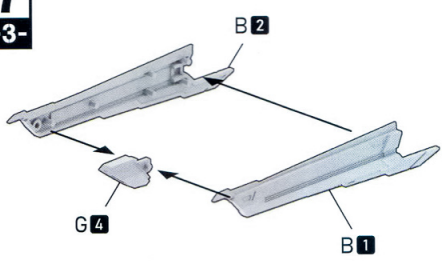

**!** 拆卸-J4/G-5  
Detach the parts J-4/G-5

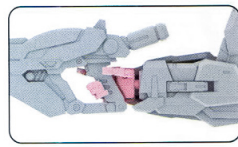
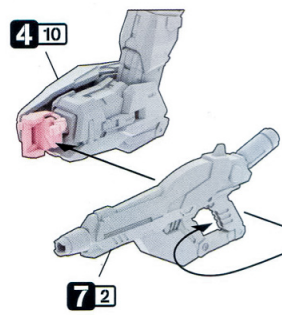

转换  
Convert

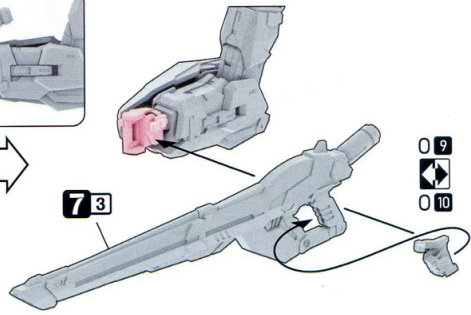

**!** 安装时注意方向  
• Pay attention to part orientation when assembling

先安装此部分  
• Assemble this part first.

# 水贴贴法 WATER STICKER METHOD

● 贴上标记水贴的位置用数字表示。● 白圆黑字为水贴纸，黑圆白文字为金属光泽的贴纸。● 请参阅下图，确定贴纸粘贴位置，以便装饰。  
 ● The position of the marked seal is indicated by numbers. ● White circle with black text for water stickers, black circle with white text for metallic gloss stickers. ● Please refer to the image below to determine the location of the sticker for decoration.

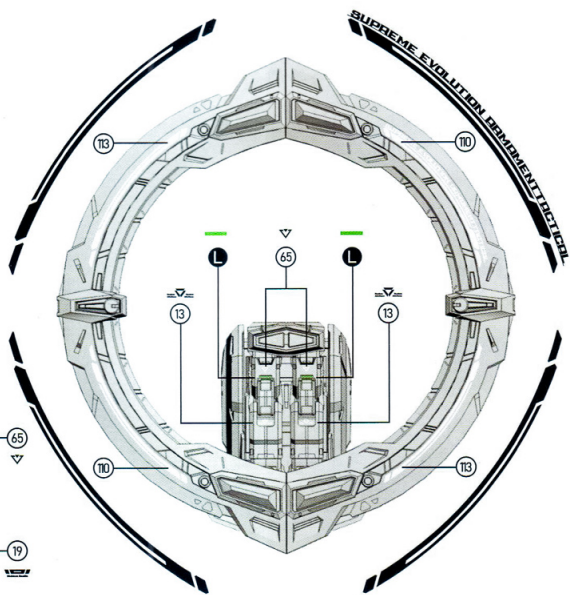
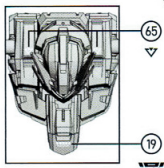
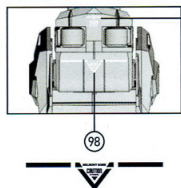
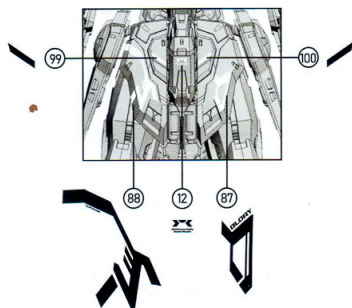
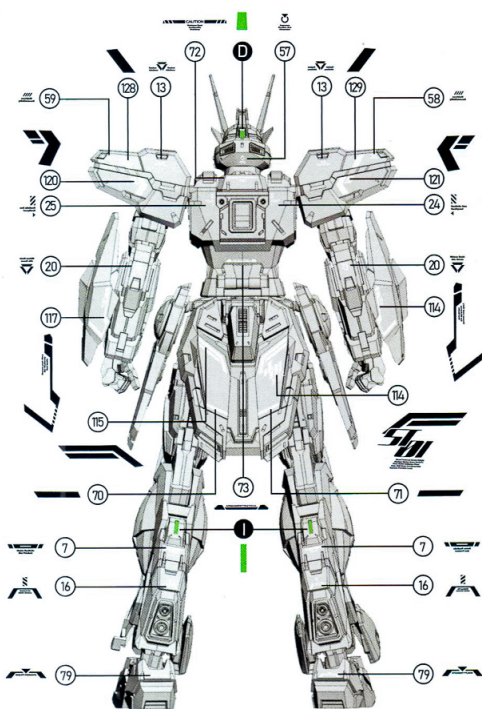
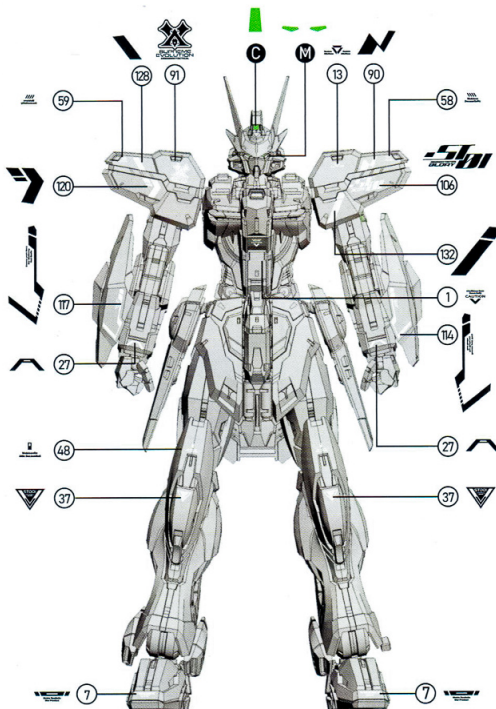



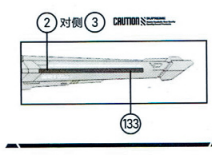
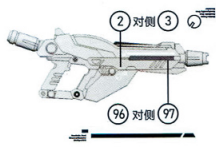
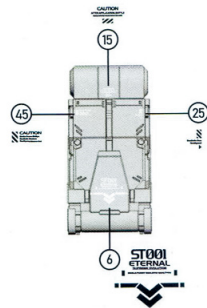
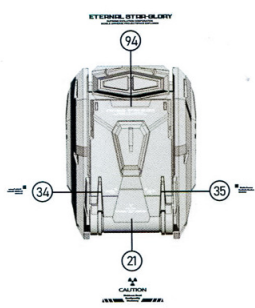
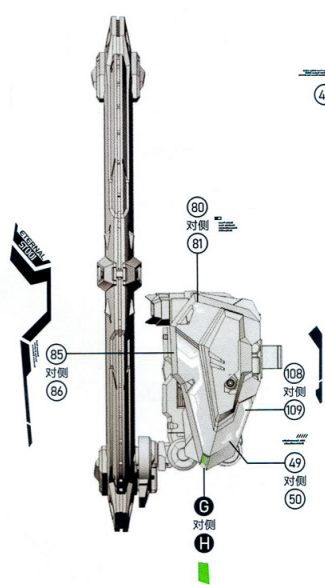
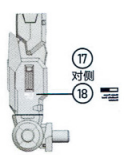
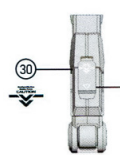
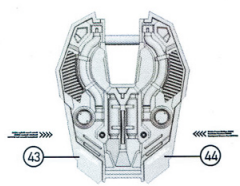
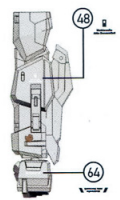
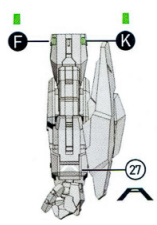
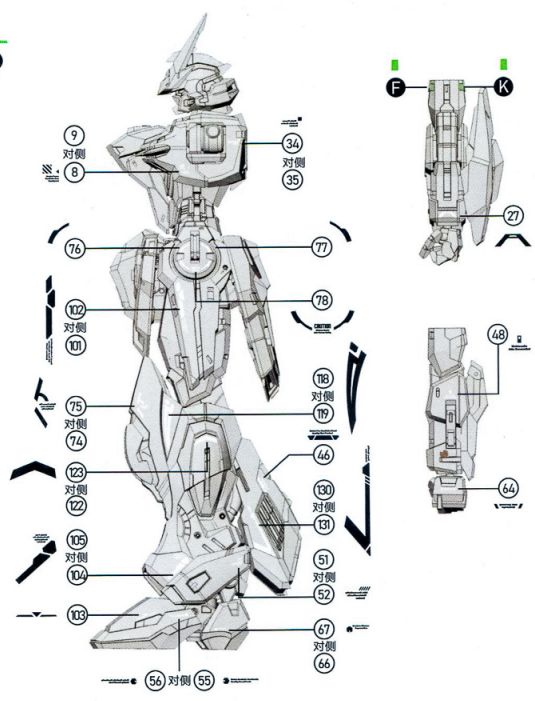
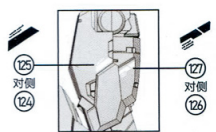
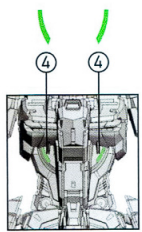
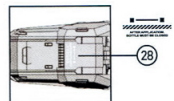
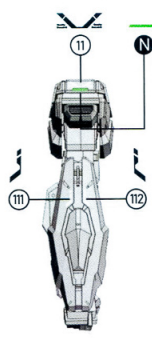
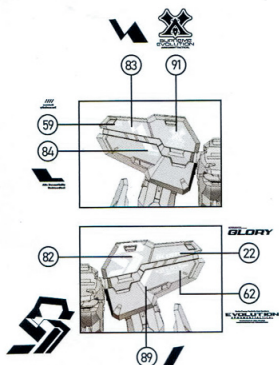

ALOKY



SUPREME  
EVOLUTION  
ARMAMENTACTICAL

超木翼 SUPER

— 2023 MADE IN CHINA —

ALORY