

M3 Grant CDL

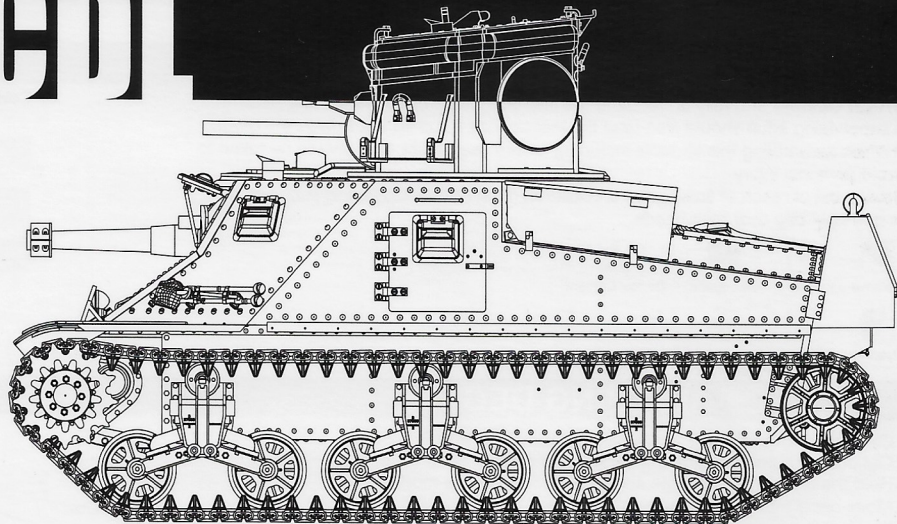

The Canal Defense Light, or CDL, was a Top-Secret project at the time of its conception by the British. This 'Secret Weapon' was an armored search light based around the use of a powerful Carbon-Arc lamp that could be used to illuminate enemy positions during night operations as well as to disorient the enemy. Carbon-Arc searchlights could produce a light as bright as 13 million candle-power. Arc-Lamps produced light via an arc of electricity suspended in the air between two carbon electrodes. To ignite the lamp, the rods were touched together, forming an arc, and then slowly drawn apart, maintaining an arc. The carbon in the rods vaporized, and the vapor produced was extremely luminous, which produced the bright light. This light was then focused by a large concave mirror. Using a series of mirrors to reflect it, the intensely bright beam of light passed through a very small vertical slit on the left of the turret face. The slit was 24 inches (61cm) tall, and 2 inches (5.1cm) wide, and had a built-in shutter that would open and close two times per second, giving the light a flickering effect. This could dazzle enemy troops, but also protected the lamp from small-arms fire. Another feature was the ability to attach an amber or blue filter to the lamp. Coupled with the flashing, this would increase the dazzling effect and could still illuminate targets areas effectively. The system also allowed for the use of an infra-red illumination bulb so that IR vision systems could see at night. The field covered by the beam was a 34 x 340 yards (31 x 311 m) at a range of 1000 yards (910 m). The lamp could also elevate and depress 10 degrees. The device was housed in a special one-man cylindrical turret that was squared off on the left and rounded on the right. The armored turret only rotated 180 degrees left or 180 degrees right, but not all the way around. The operator inside, known as the 'observer', was positioned in the left side of the turret and partitioned off from the lamp system.

Several vehicles were converted to CDLs, including the Matilda II, the Churchill, and the M3 Lee. Ultimately, the M3 Grant was always the intended mount for the Canal Defence Light because it was faster and retained its 75mm tank gun, allowing it to defend itself much more effectively. Additionally, the M3 Grant was mostly considered obsolete, so there was a surplus of the tanks available. The Grant CDL replaced the secondary armament turret atop the M3A1, but the addition of a dummy gun next to the beam slit gave it the appearance of a normal gun tank. The type D turret was also armed with a ball mount for a British BESA.

M3 Grant CDLs were used as US & British forces crossed the Rhine & Elbe rivers under the 79th Armored Division, where they protected against German mines, frogmen, and even mini-subs. These tanks drew heavy fire with one of the CDL's being knocked out. Some CDL's were also sent to India under the 43rd RTR, and were stationed there for the planned invasion of Malaya in February 1946, but the war with Japan ended before they could be put to use in their intended role. These CDL's ultimately saw action when they successfully assisted the Calcutta Police in the riots of 1946. The sole surviving M3 Grant CDL can be found at the Cavalry Tank Museum in Ahmednagar, India.

READ BEFORE ASSEMBLY

CAUTION

- Read carefully and fully understand the instructions before commencing assembly. A supervising adult should also read the instructions if a child assembles the model.
- When assembling this kit, tools including knives used. Extra care should be taken to avoid personal injury.
- Keep out of reach of small children. Children must not be allowed to suck any part, or pull vinyl bag over their heads.



Remove



Drill



Be Careful



Do Not Cement



Optional



Heating



Instant Glue
for Metal

PAINTS REQUIRED

Color info and profiles by Mig Jimenez

A.MIG 033

Rubber &
Tires

A.MIG 035

Dark Tracks

A.MIG 038

Old Wood

A.MIG 045

Gun Metal

A.MIG 093

Crystal Red

A.MIG 094

Crystal Glass

A.MIG 195

Silver

A.MIG 096

Crystal
Periscope Green

A.MIG 926

Olive
Drab Base

APPLYING DECALS

REMOVING PE

1. Clean the model surface with a wet cloth.
2. Cut out each decal design from sheet, and dip it in tepid water for 15~20 sec.
3. Hold the backing sheet edge and slide decal onto the model.
4. Move decal into position by wetting decal with finger.
5. Press decal gently down with a soft cloth until excess water and air bubbles are gone.

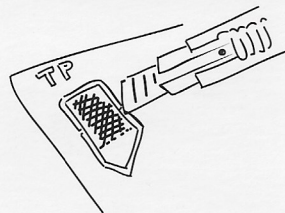
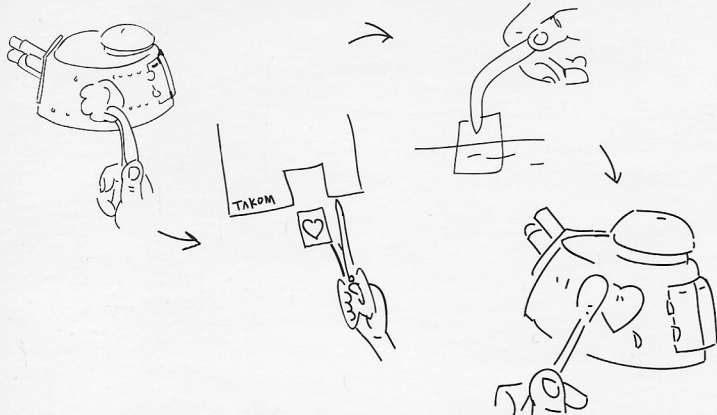

Be careful not to hurt when removing PE parts.

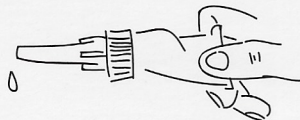

Secure using instant glue (not included).

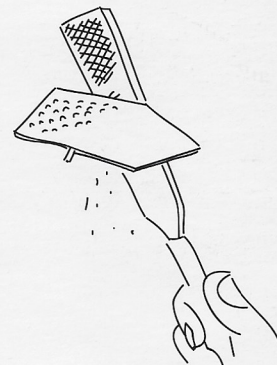

Finish using file.

PARTS

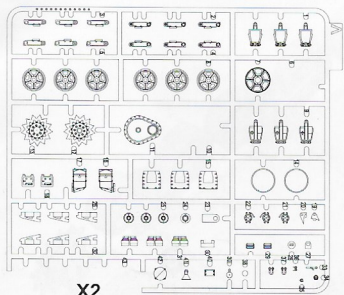

X2

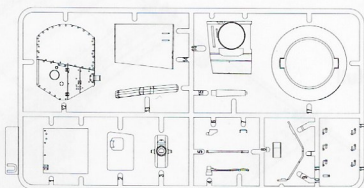
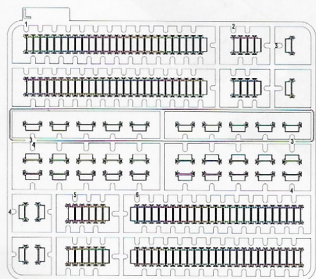
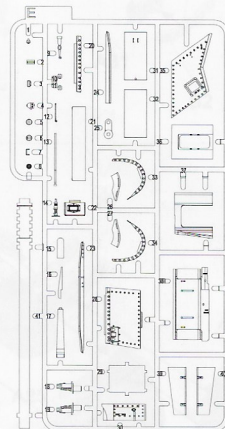
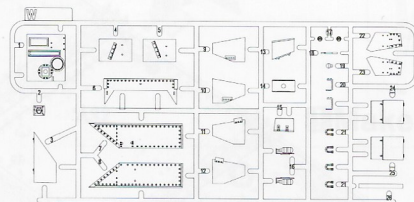
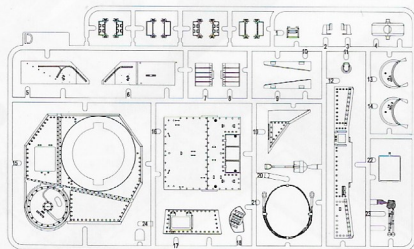

X2

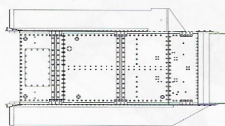
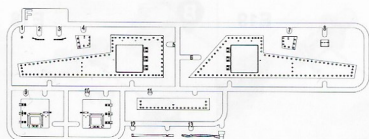

Upper Hull

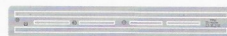

TP



Decal

1

BEFORE ASSEMBLY

CAUTION

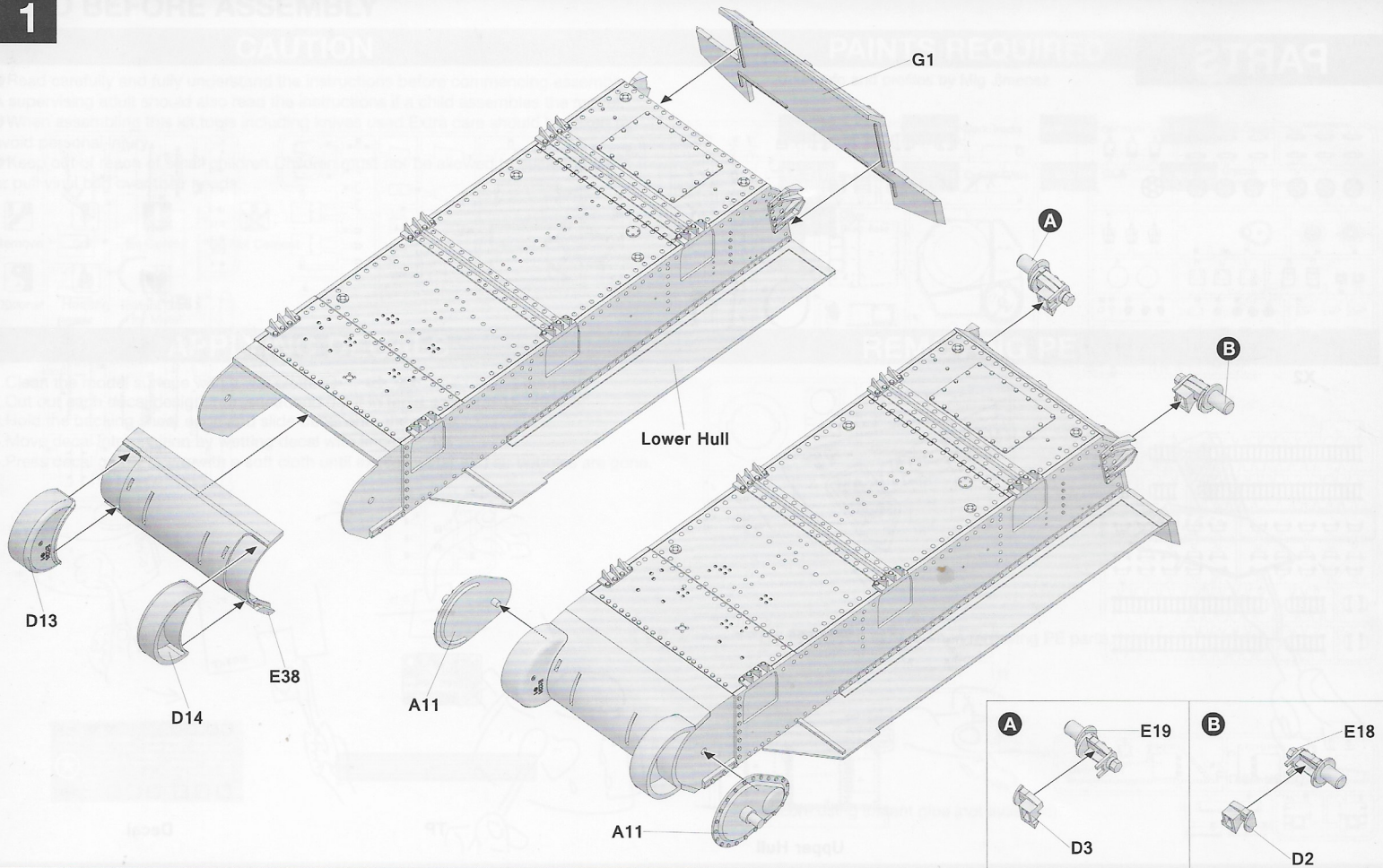

3

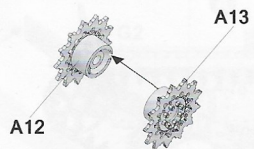
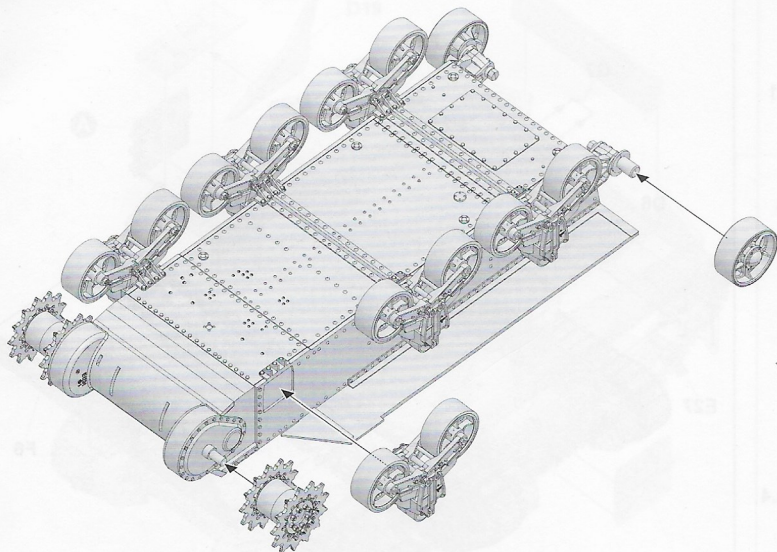

Make 2

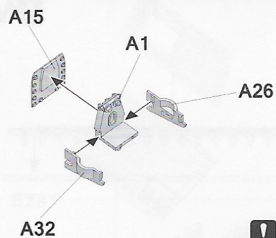
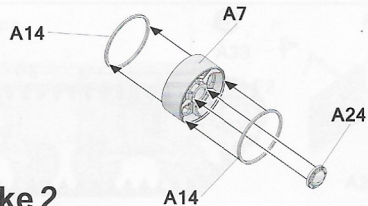

Make 6

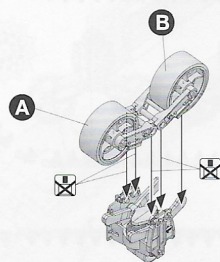
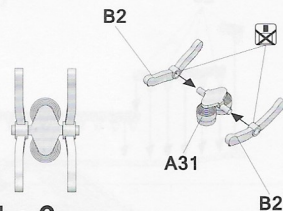

Make 6

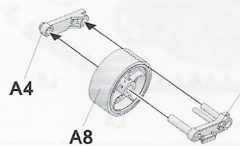
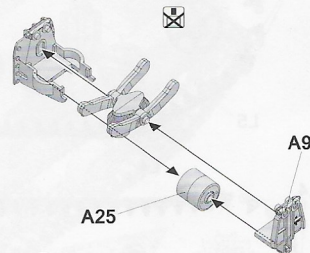

A B

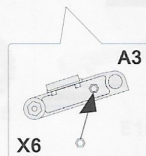
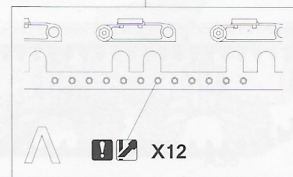
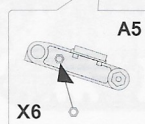
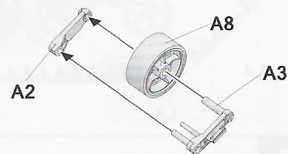

3

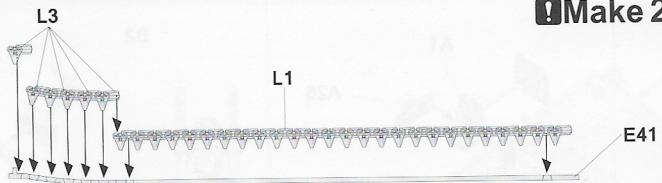

Make 2

5

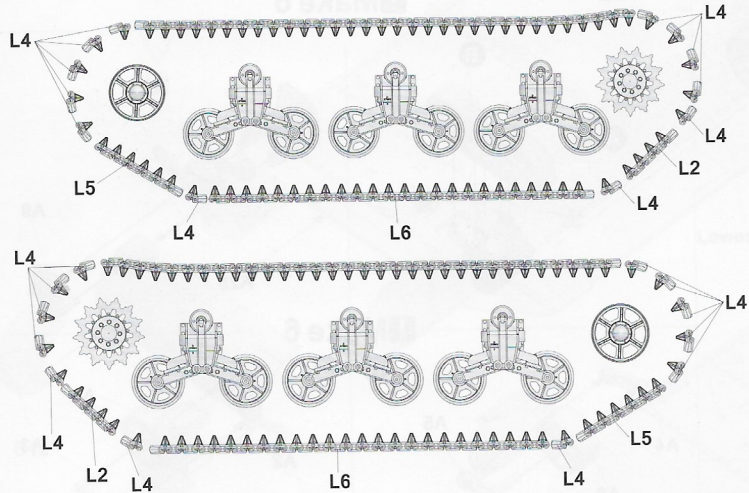
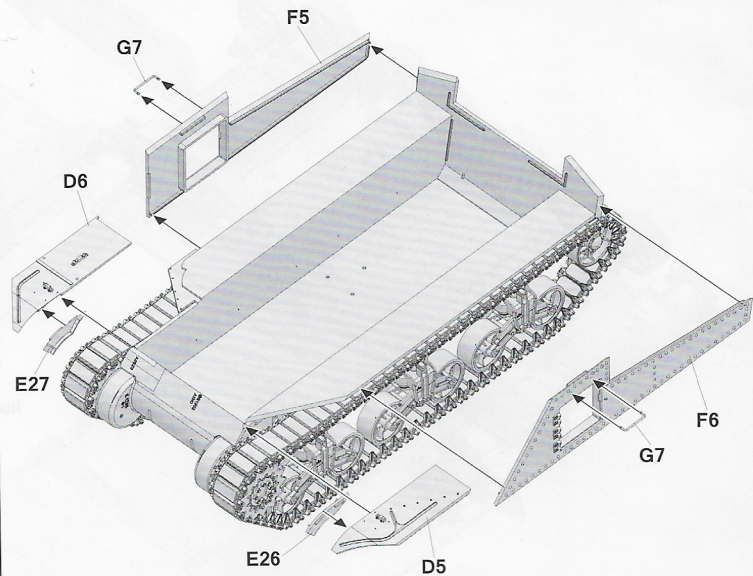

4

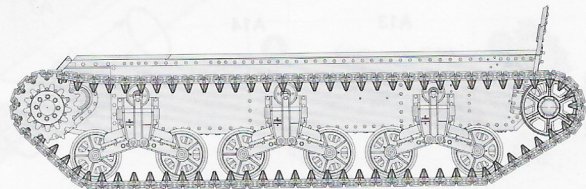
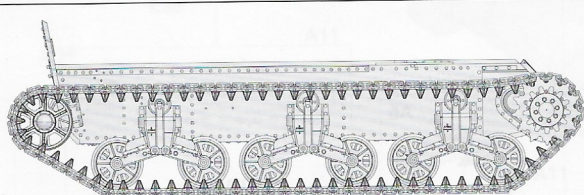

5

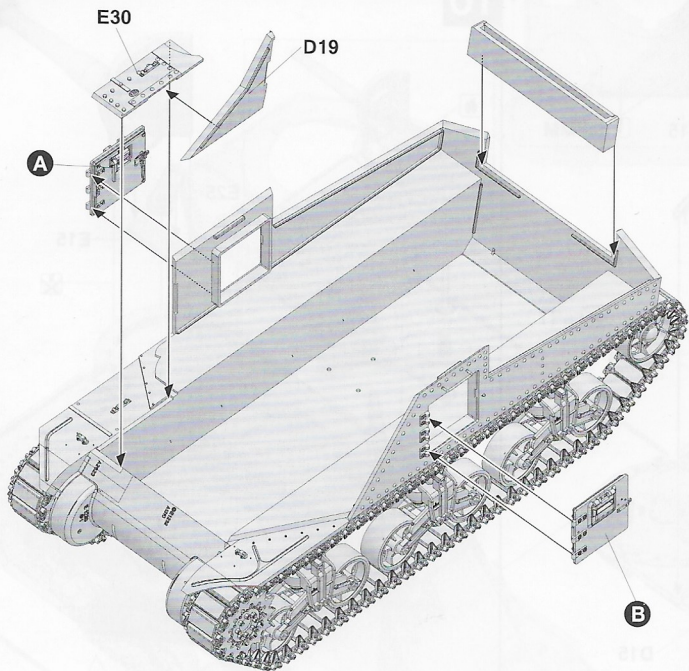
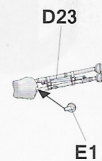
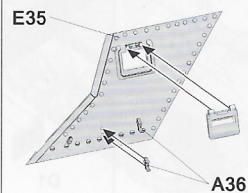
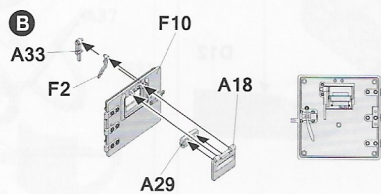
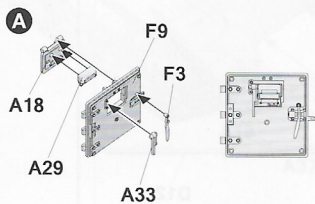
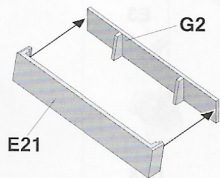
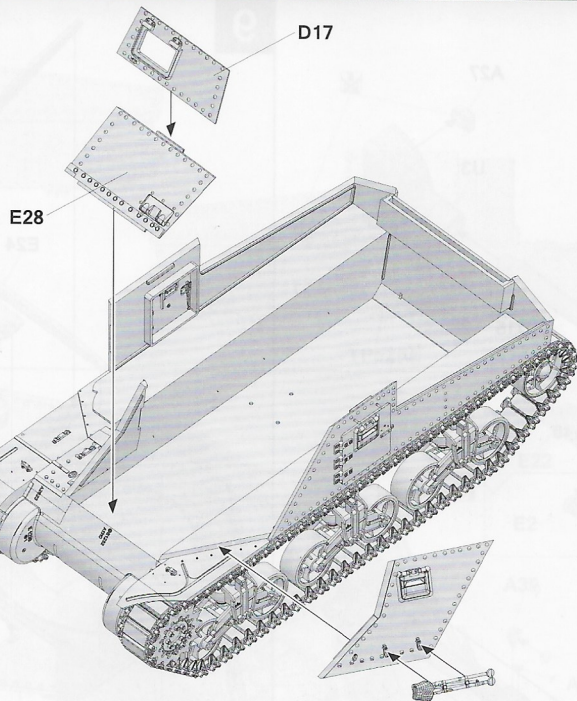
6**7**

8

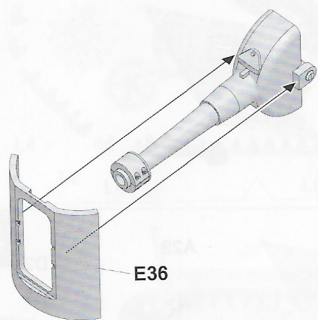
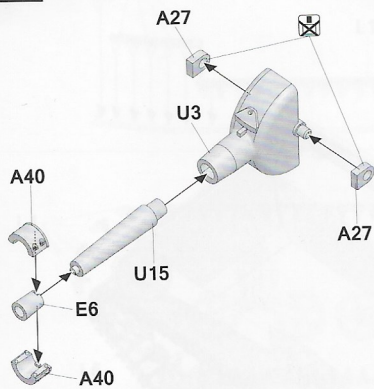

9

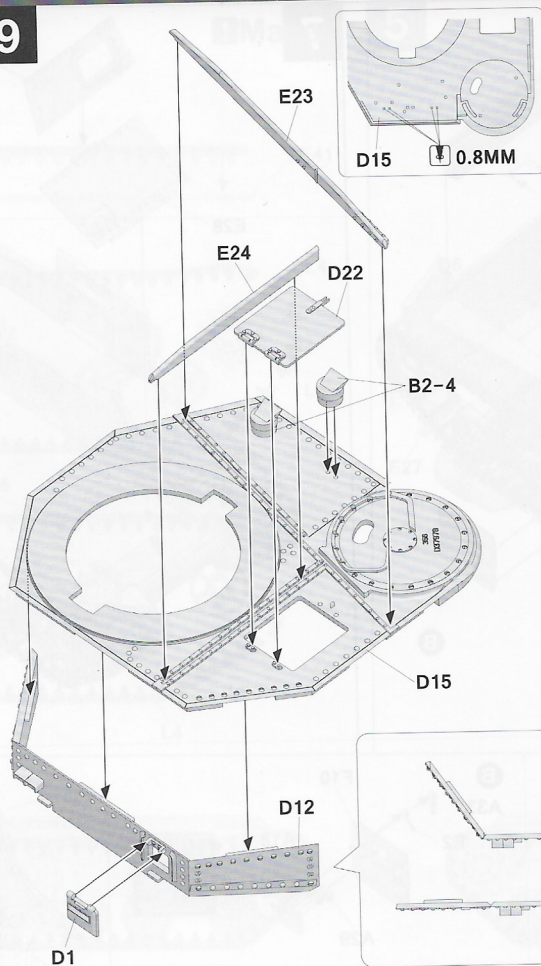

10

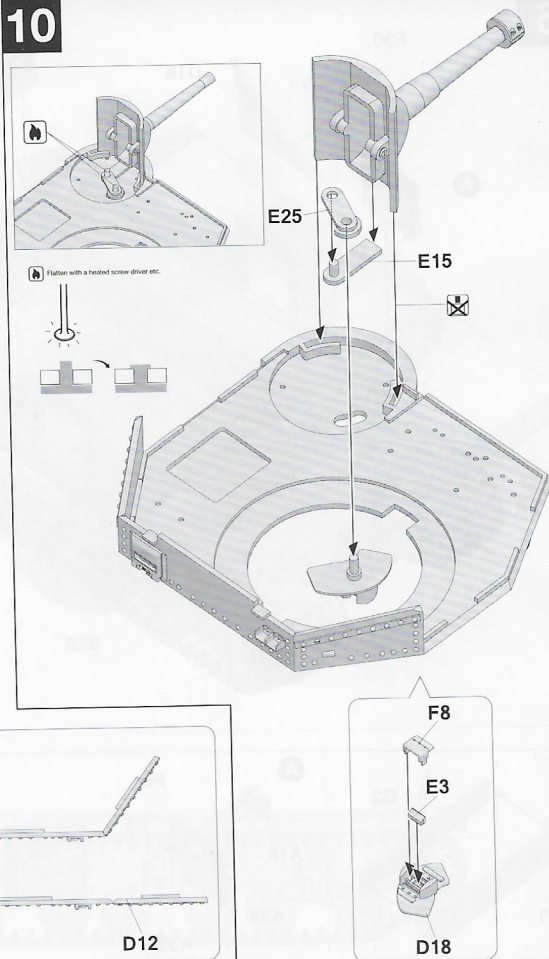

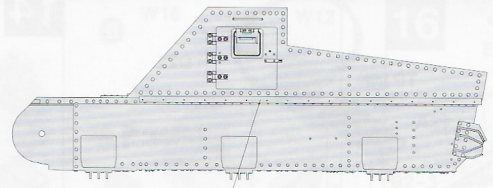
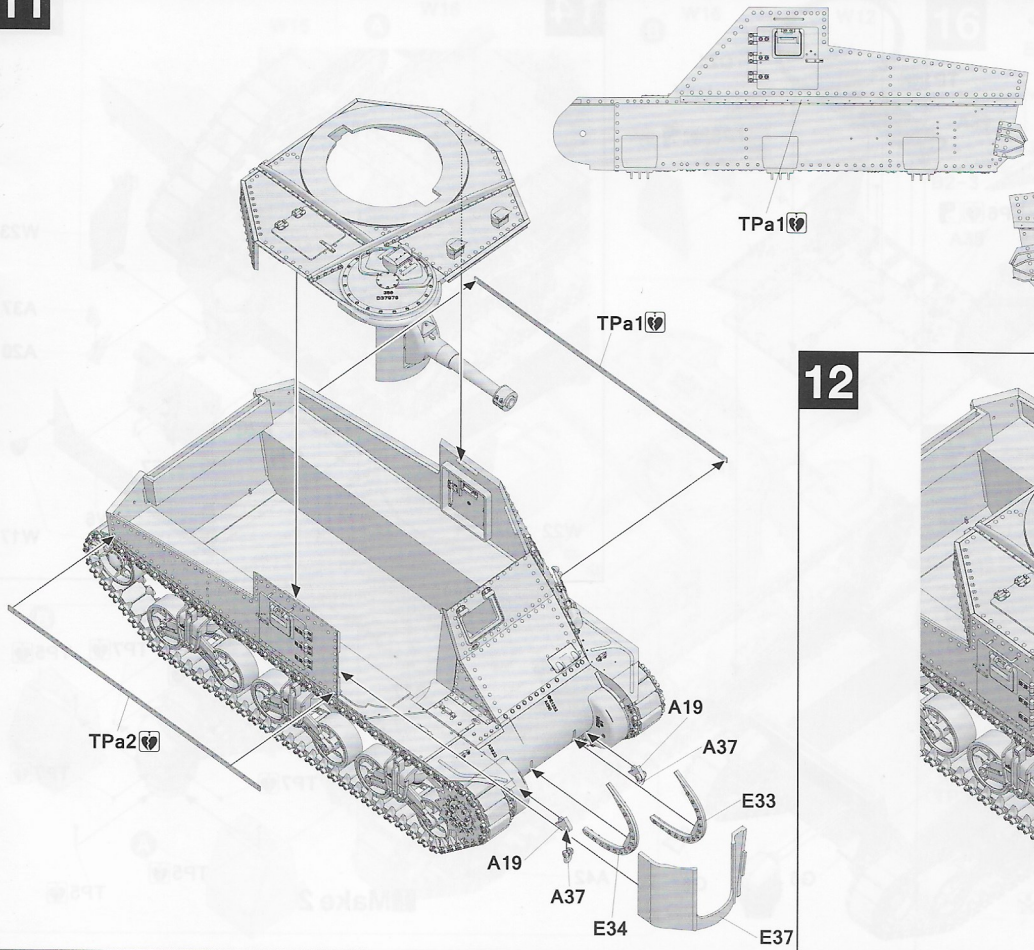

TPa1

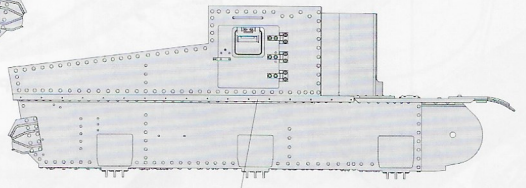

TPa2

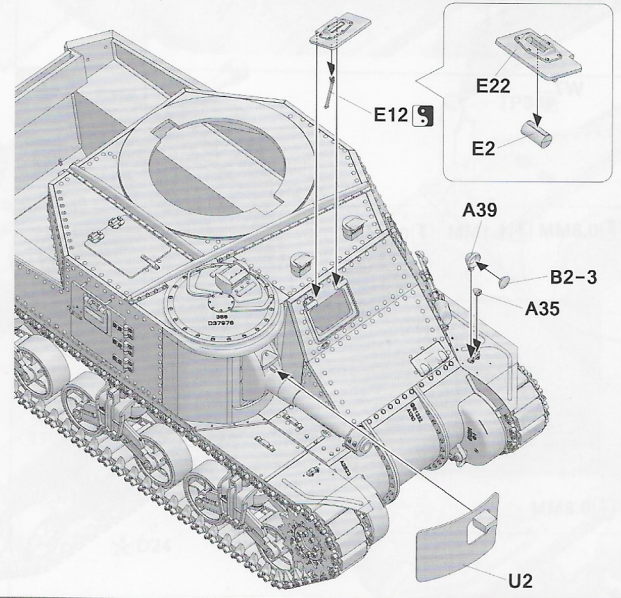

E22

E2

E12

A39

B2-3

A35

U2

13

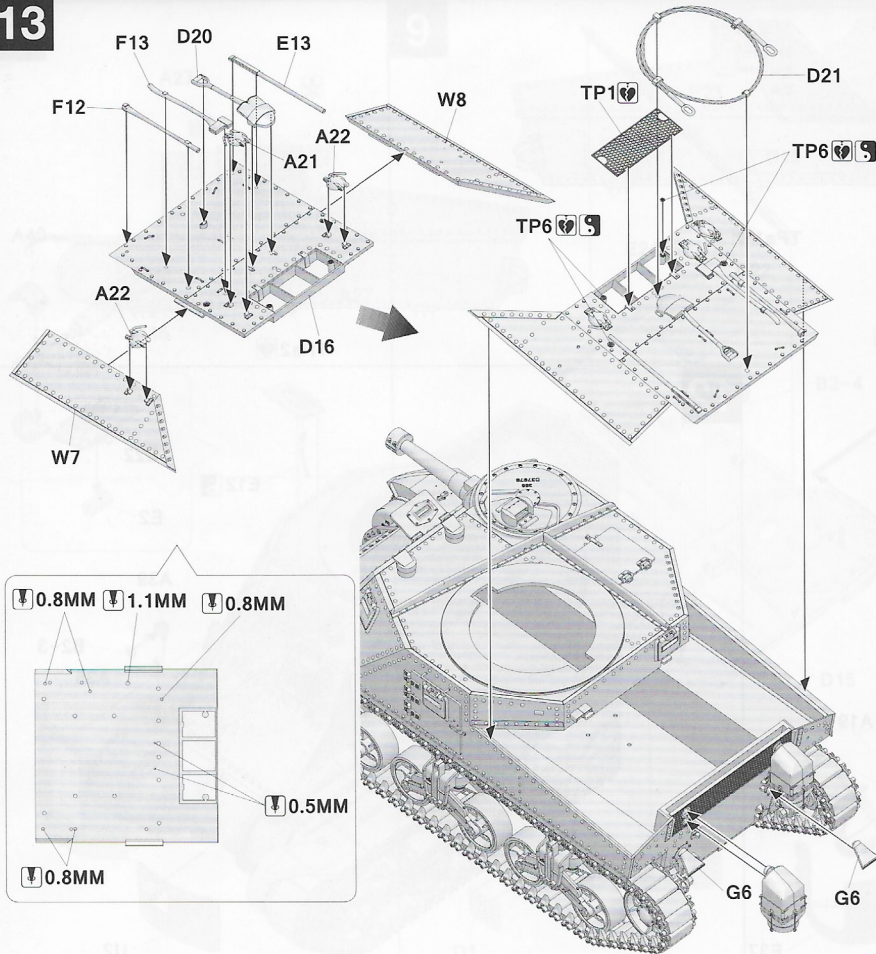

14

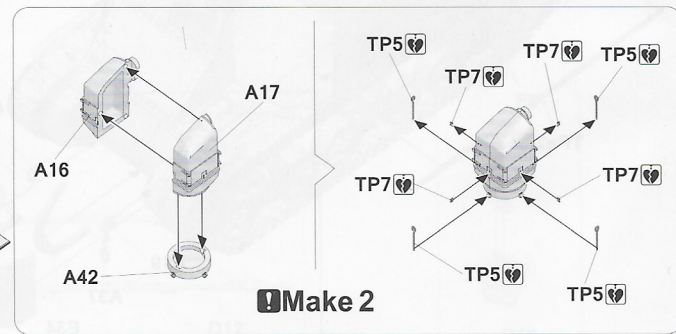
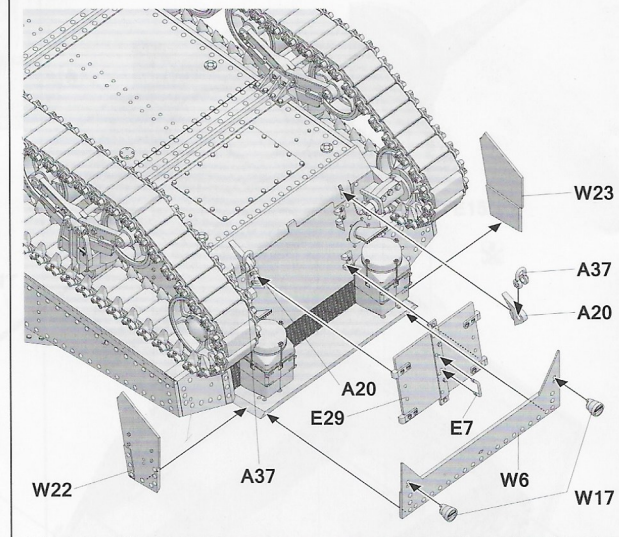

15

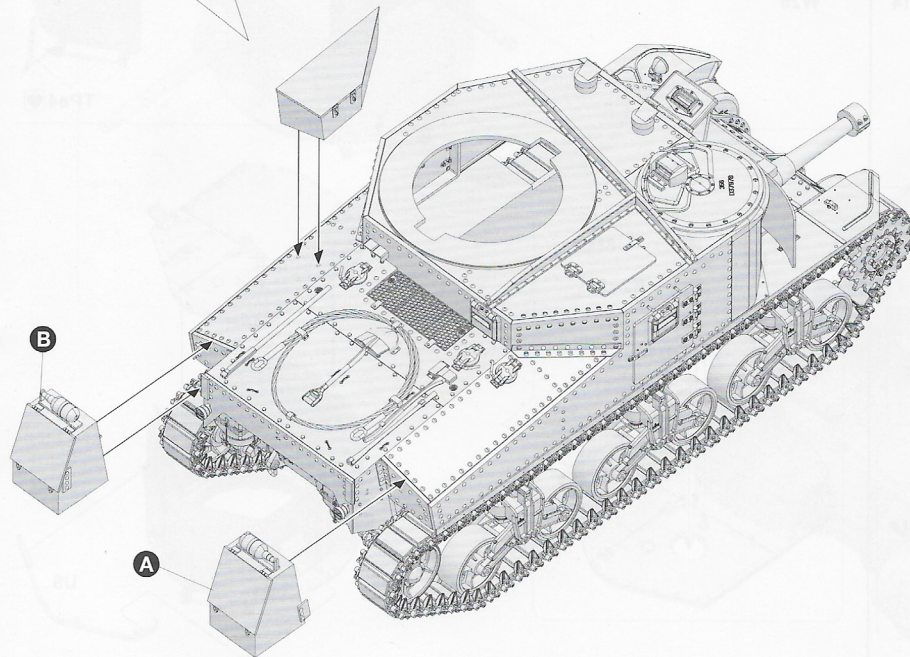
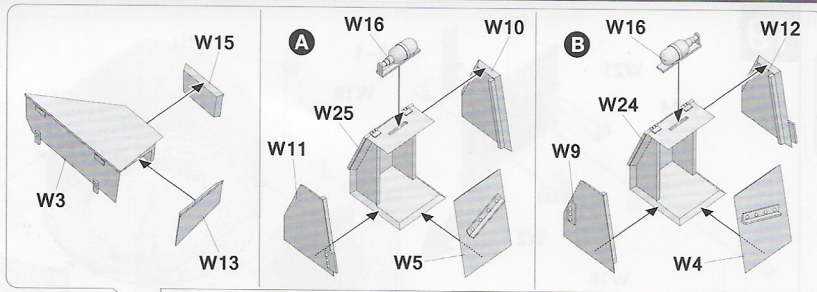

16

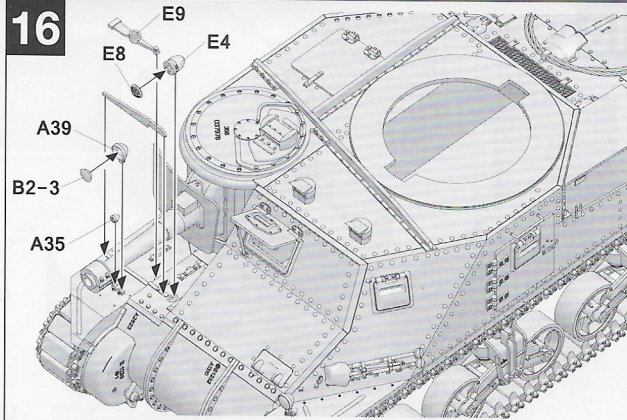

17

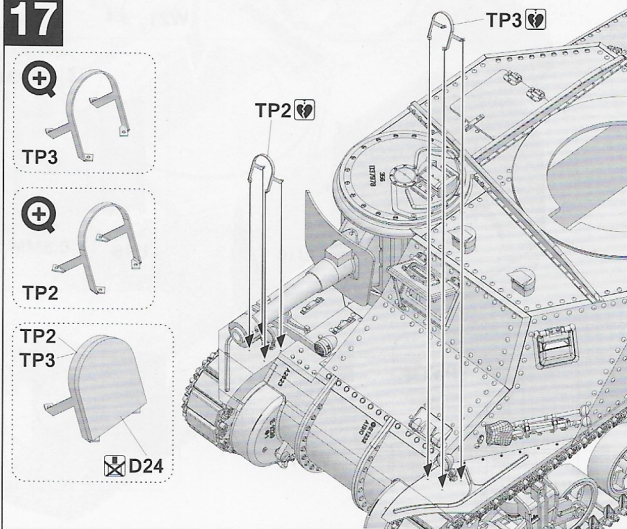

18

0.8MM
U14

0.8MM

U14

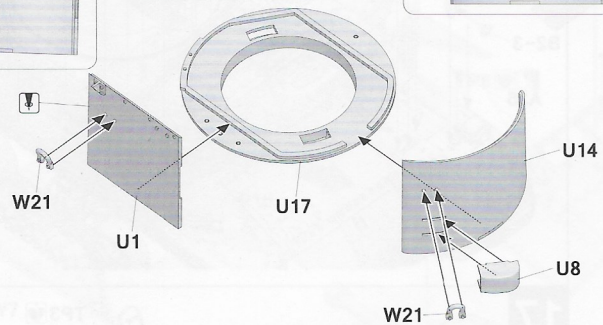
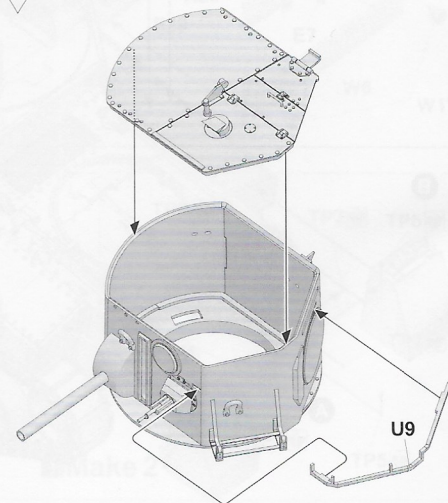
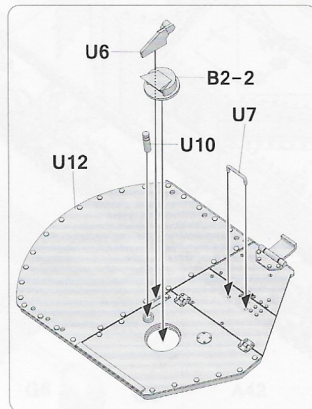
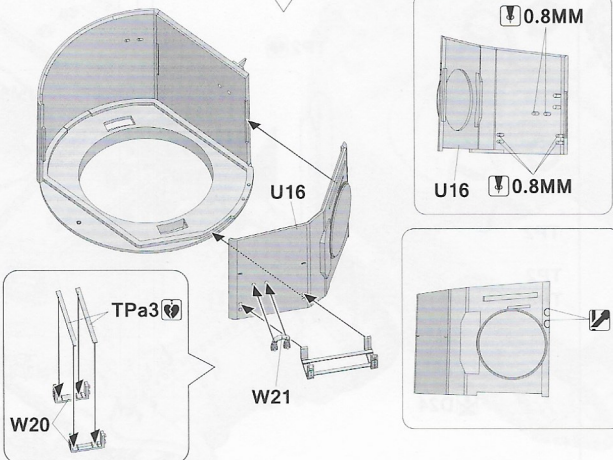
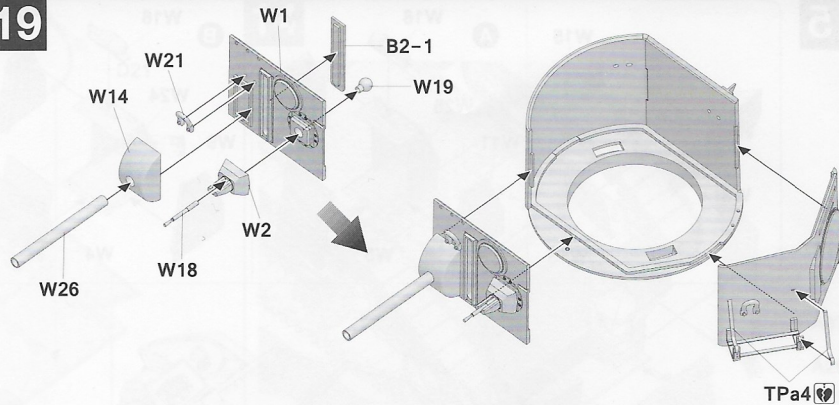
**19**

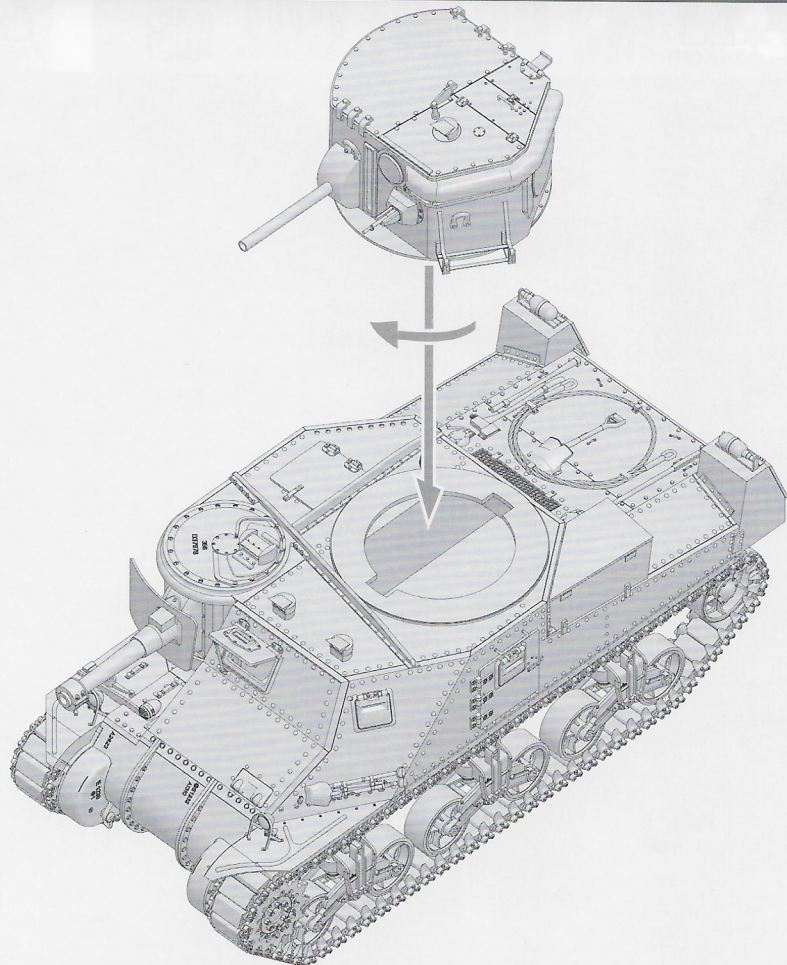
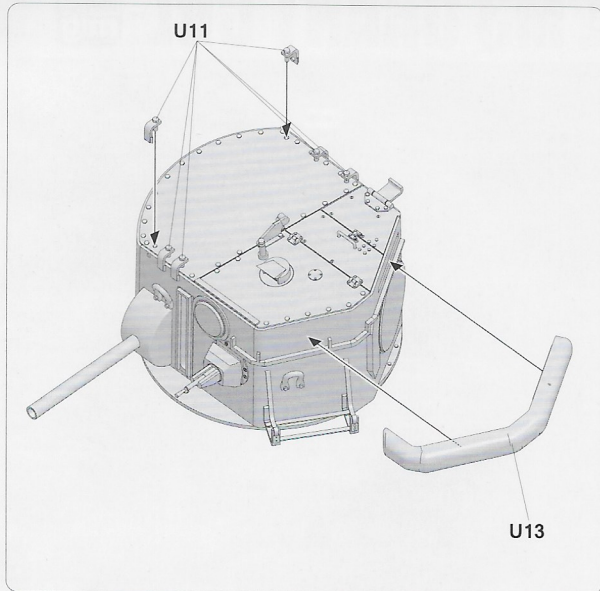

Painting and Marking Guide

A.MIG 033 Rubber & Tires A.MIG 035 Dark Tracks A.MIG 036 Old Wood A.MIG 045 Gun Metal

A.MIG 093 Crystal Red A.MIG 094 Crystal Green A.MIG 096 Crystal Periscope Green A.MIG 193 Silver

A.MIG 926 Olive Drab Base

TAKOM Ref: 2116

British Medium Tank M3 Grant CDL

B Squadron, "BADGER", 79th Armoured Division,
Elbe River Crossing, Lützenburg, Germany, April 1945.

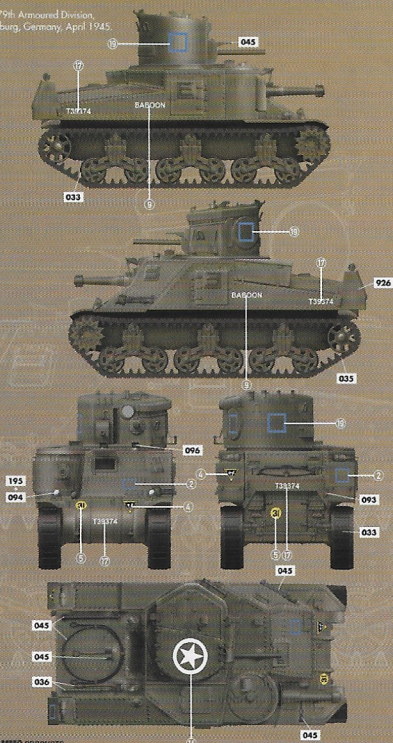

WEATHERING STEPS WITH AMMO PRODUCTS

1 GENERAL WASH

A.MIG-1093 Dark Brown Wash for Green Vehicles

2 PRIMER

A.MIG-1507 TAN for Yellow Green

3 STRIPING

A.MIG-1208 Rainmarks Effects

A.MIG-1022 Trucks Wash

4 DUST

A.MIG-3004 Europe Earth

A.MIG-1733 Loose Ground

5 HEAVY MUD

A.MIG-1703 Mott Ground

A.MIG-1408 Fresh Engine Oil

Painting and Marking Guide

A.MIG 033 Rubber & Tires A.MIG 035 Dark Tracks A.MIG 036 Old Wood A.MIG 045 Gun Metal

A.MIG 093 Crystal Red A.MIG 094 Crystal Green A.MIG 096 Crystal Periscope Green A.MIG 193 Silver

A.MIG 926 Olive Drab Base

TAKOM Ref: 2116

British Medium Tank M3 Grant CDL

B Squadron, "BADGER", 79th Armoured Division,
Elbe River Crossing, Beckede, Germany, April 1945.

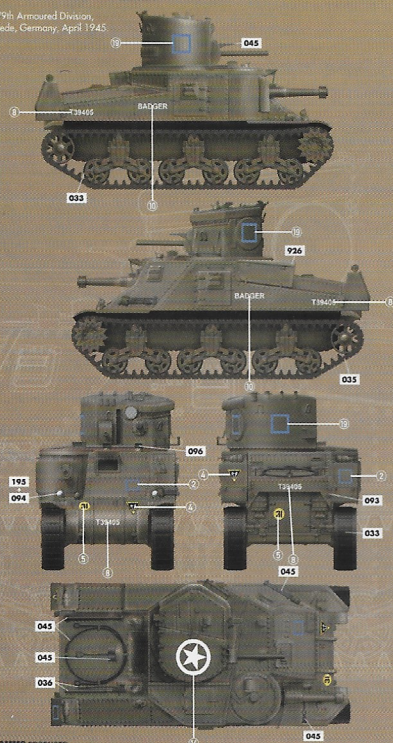

WEATHERING STEPS WITH AMMO PRODUCTS

1 GENERAL WASH

A.MIG-1093 Dark Brown Wash for Green Vehicles

2 PRIMER

A.MIG-1507 TAN for Yellow Green

3 STRIPING

A.MIG-1208 Rainmarks Effects

A.MIG-1022 Trucks Wash

4 DUST

A.MIG-3004 Europe Earth

A.MIG-1733 Loose Ground

5 HEAVY MUD

A.MIG-1703 Mott Ground

A.MIG-1408 Fresh Engine Oil

Painting and Marking Guide

TAKOM Ref: 2116

British Medium Tank M3 Grant CDL

B Squadron, "CAVALIER", 79th Armoured Division,
Rhine River Crossing, Rees, Germany, March 1945.

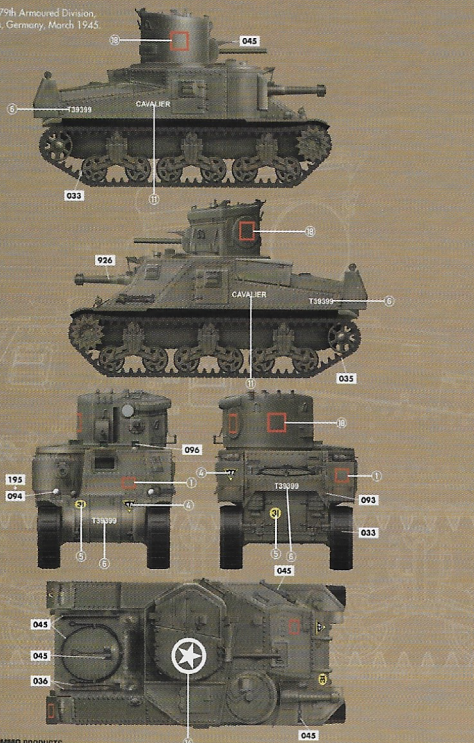

WEATHERING STEPS WITH AMMO PRODUCTS

1 GENERAL WASH

A.MIG-1002 Dark Brown Wash for Green Vehicles

2 FILTER

A.MIG-1507 TAN for Yellow Green

3 STREAKING

A.MIG-1108 Rainmarks Effects

4 TRACK WASH

A.MIG-1002 Tracks Wash

5 DUST

A.MIG-3004 Europe Earth

6 SPLASHES

A.MIG-1732 Loose Ground

7 HEAVY RIND

A.MIG-1723 Moist Ground

8 GREASE & OIL

A.MIG-1406 Fresh Engine Oil

Painting and Marking Guide

TAKOM Ref: 2116

British Medium Tank M3 Grant CDL

A Squadron, "GIRAFFE", 79th Armoured Division,
Germany, March 1945.

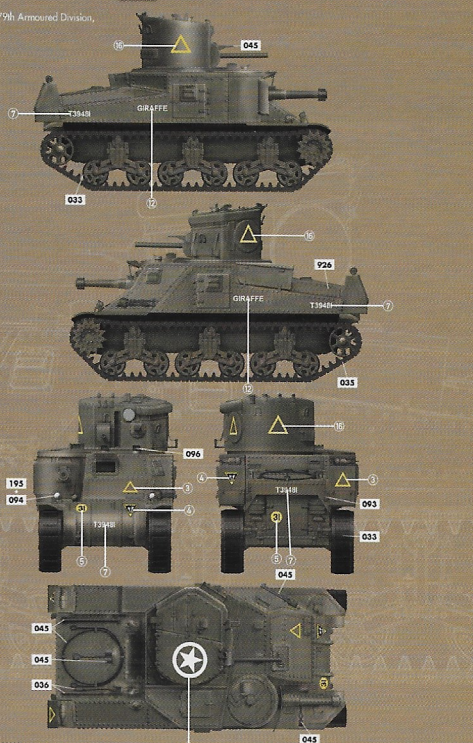

WEATHERING STEPS WITH AMMO PRODUCTS

1 GENERAL WASH

A.MIG-1002 Dark Brown Wash for Green Vehicles

2 FILTER

A.MIG-1507 TAN for Yellow Green

3 STREAKING

A.MIG-1108 Rainmarks Effects

4 TRACK WASH

A.MIG-1002 Tracks Wash

5 DUST

A.MIG-3004 Europe Earth

6 SPLASHES

A.MIG-1732 Loose Ground

7 HEAVY RIND

A.MIG-1723 Moist Ground

8 GREASE & OIL

A.MIG-1406 Fresh Engine Oil

Painting and Marking Guide

A.MIG 033 Rubber & Tires	A.MIG 035 Dark Tracks	A.MIG 036 Old Wood	A.MIG 045 Gun Metal
A.MIG 092 Crystal Red	A.MIG 094 Crystal Glass	A.MIG 090 Crystal Persepol Green	A.MIG 195 Silver
A.MIG 926 Olive Dark-brown			

TAKOM Ref: 2116

British Medium Tank M3 Grant CDL

A Squadron, 'GORILLA', 79th Armoured Division, Germany, March 1945.

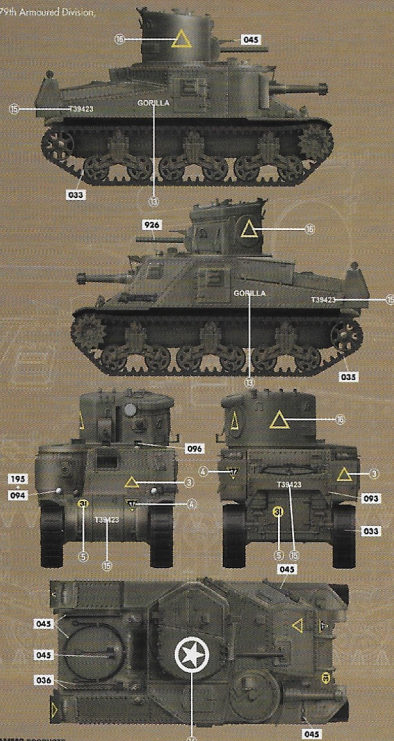

WEATHERING STEPS WITH AMMO PRODUCTS

- | | | | |
|---|--|--|--|
| 1 GENERAL WASH
A.MIG-1501 Ox's Screen Wash for Green Vehicles | 2 STREAKING
A.MIG-1208 Rainmarks Effects | 3 DIRT
A.MIG-3004 Europe Earth | 4 HEAVY MUD
A.MIG-3004 Europe Earth |
| 5 FILTER
A.MIG-1507 TAN for Yellow Green | 6 TRACK WASH
A.MIG-1002 Tracks Wash | 7 SPLASHES
A.MIG-1792 Loose Ground | 8 GREASE & OIL
A.MIG-1408 Fresh Engine Oil |

PANTHER Ausf.D

Early / Mid
Production
2in1

BONUS

Transparent shell

GERMAN TANK Sd.Kfz. 171

- A. DETAIL CO. STATIC DISPLAY PLASTIC MODEL.
- A. TRACK ASSEMBLY IS ADDED WITH THE USE OF A JIG.
- A. LINE & LENGTH STYLE TRACKS INCLUDED.
- A. ALL HATCHES CAN BE BUILT IN OPEN OR CLOSED POSITION.
- A. PE INCLUDED.
- A. 4 TYPES OF MARKINGS.

Full Interior

1/35
No.2103



Designed by
Tobias Müller
in China

- A. THIS IS NOT A TOY.
- A. READY TO ASSEMBLE PRECISION MODEL KIT.
- A. INTENDED FOR COLLECTIONS OF AGE 14 YEARS AND ABOVE.
- A. MODEL MAY VARY FROM IMAGE ON BOX.
- A. CEMENT AND PAINT NOT INCLUDED.



PANTHER Ausf.D

Sd.Kfz. 171

LATE Production
w/Zimmerit



- A. DETAIL CO. STATIC DISPLAY PLASTIC MODEL.
- A. TRACK ASSEMBLY IS ADDED WITH THE USE OF A JIG.
- A. LINE & LENGTH STYLE TRACKS INCLUDED.
- A. ALL HATCHES CAN BE BUILT IN OPEN OR CLOSED POSITION.
- A. PE INCLUDED.
- A. 4 TYPES OF MARKINGS.
- A. PRIME NOT INCLUDED.



1/35
No.1034

- A. THIS IS NOT A TOY.
- A. READY TO ASSEMBLE PRECISION MODEL KIT.
- A. INTENDED FOR COLLECTIONS OF AGE 14 YEARS AND ABOVE.
- A. MODEL MAY VARY FROM IMAGE ON BOX.
- A. CEMENT AND PAINT NOT INCLUDED.

Zimmerit Pattern
created by
JASON
Designed by
The Designer
in China



Full Interior

2018/2116

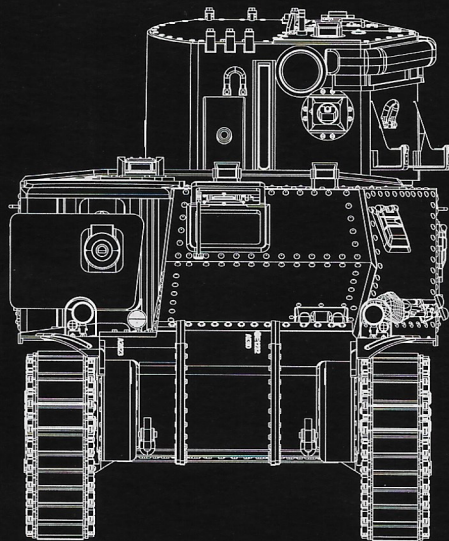

You can find TAKOM on Facebook.com