

Assembly instructions

15

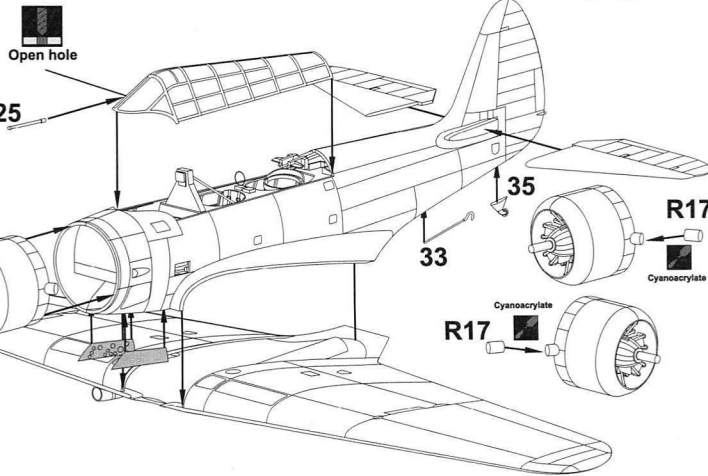

16

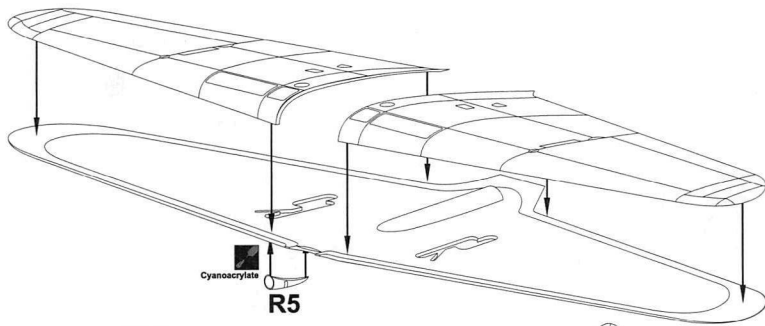
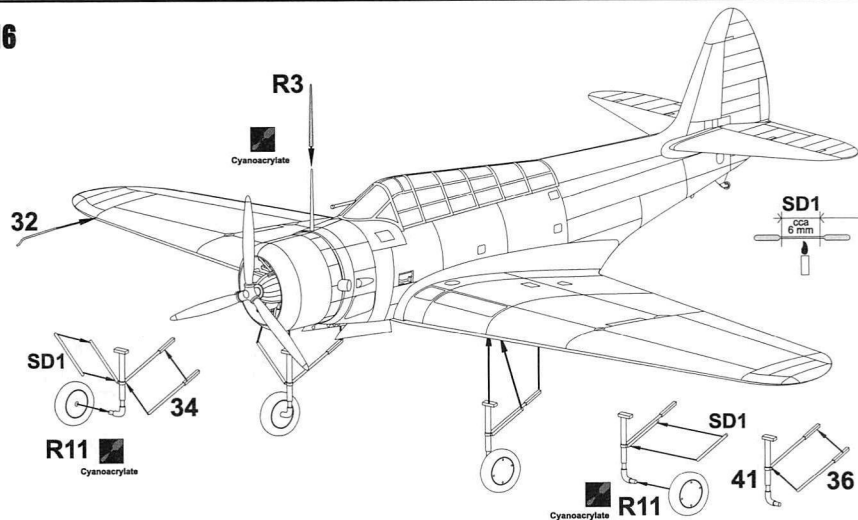

AZ model
Plastic kits

Douglas TBD DEVASTATOR

Plastic model

scale : 1/72

History note

The Douglas TBD Devastator was a torpedo bomber of the United States Navy, ordered in 1934, first flying in 1935 and entering service in 1937. At that point, it was the most advanced aircraft flying for the USN and possibly for any navy in the world. However, the fast pace of aircraft development caught up with it, and by the time of the Japanese attack on Pearl Harbor the TBD was already outdated.

It performed well in some early battles, but in the Battle of Midway the Devastators launched against the Japanese fleet were almost totally wiped out.

The type was immediately withdrawn from front line service, replaced by the Grumman TBF Avenger.

Plastic parts

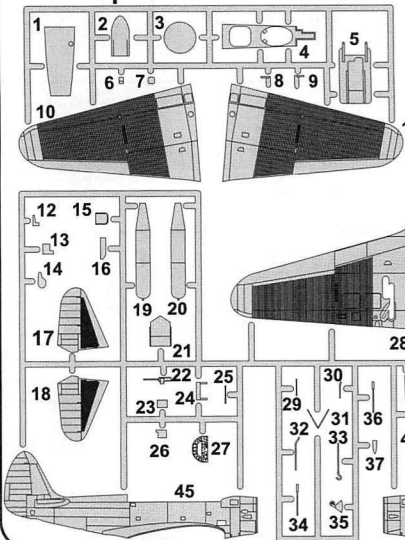

Resin parts

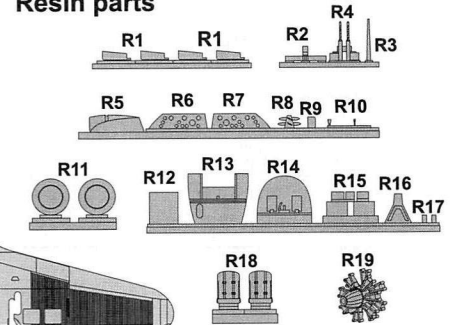

Clear parts

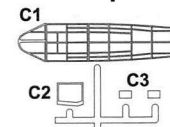

Symbols

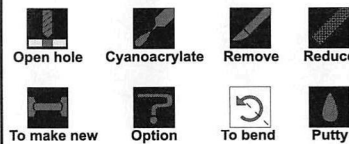

	Colour name	Humbrol	Colour name	Humbrol	
A	Black	H33	G	Aluminium	H56
B	White	H34	H	Silver	H11
C	Interior Green	H78	I	Gunmetal	H53
D	Zinc Chromate	H53	J	Red	H132
E	Brown	H186	K	Tyre	H85
F	Yellow	H24	L	Rust	H113

Assembly instructions

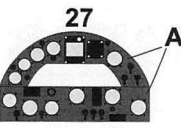
1 

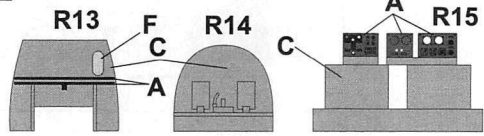
2 

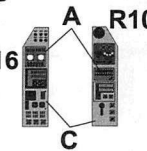
3 

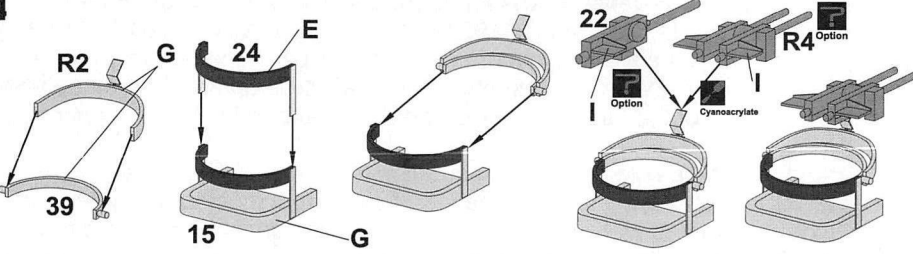
4 

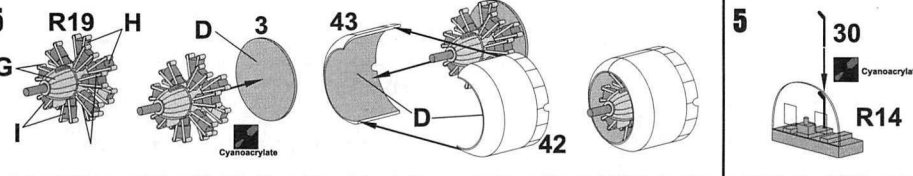
5 

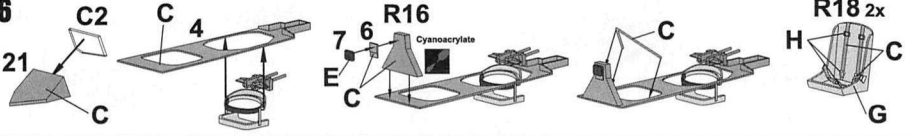
6 

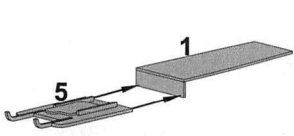
7 

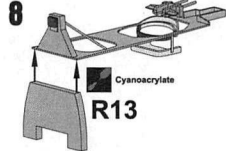
8 

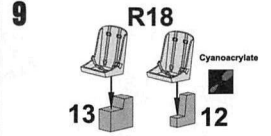
9 

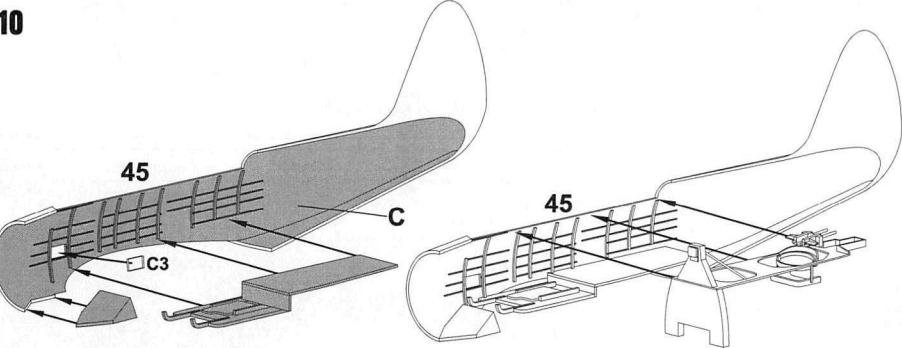
10 

Assembly instructions

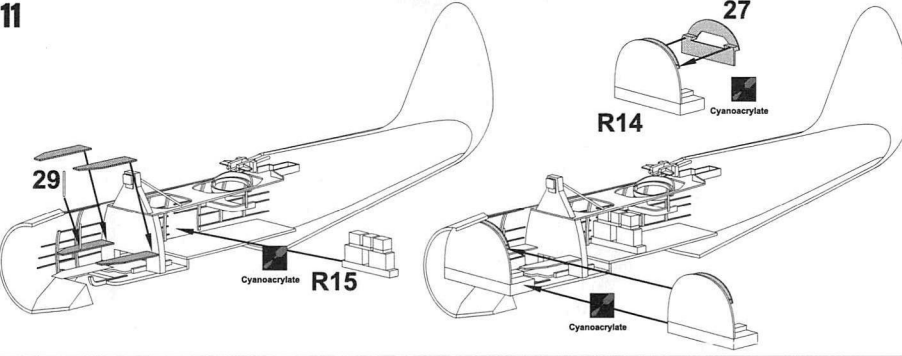
11 

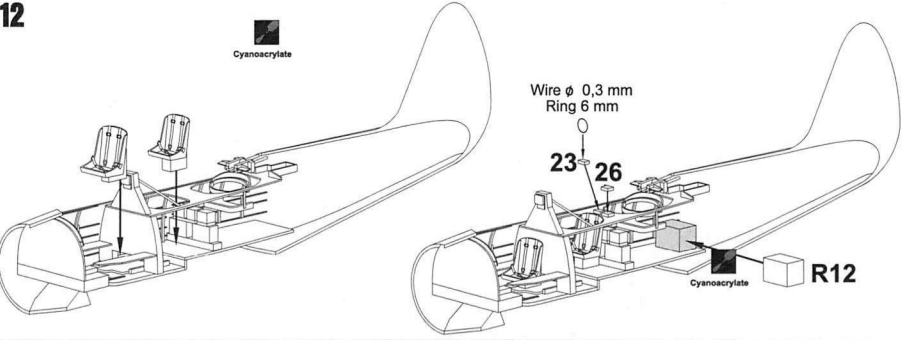
12 

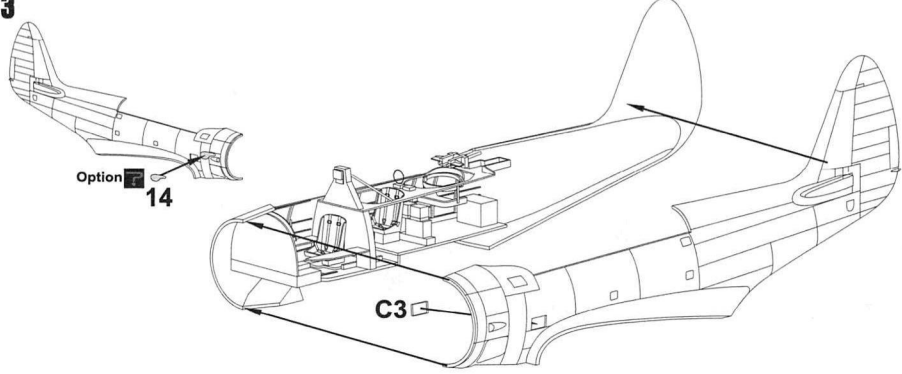
13 

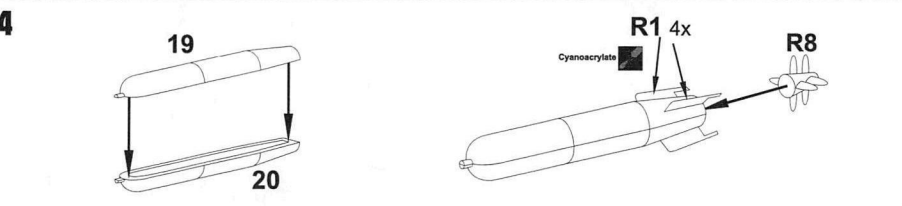
14 

1

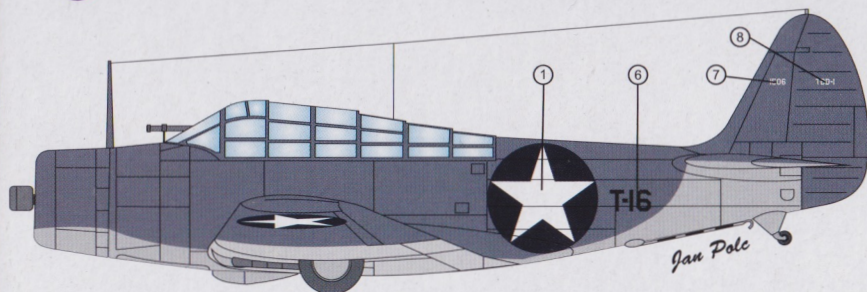

TBD - 1 „Devastator”, BuNo. 1506, T-16 of VT-8, USS Hornet, 4th June 1942
Aircraft flown by Lt Cdr J. C. Waldron and ACRM H. F. Hobbs. VT-8 was the only unit of USS Hornet which found Japanese carriers off Midway that day. It was destroyed completely. Waldron and Hobbs both lost their lives in T-16.

2

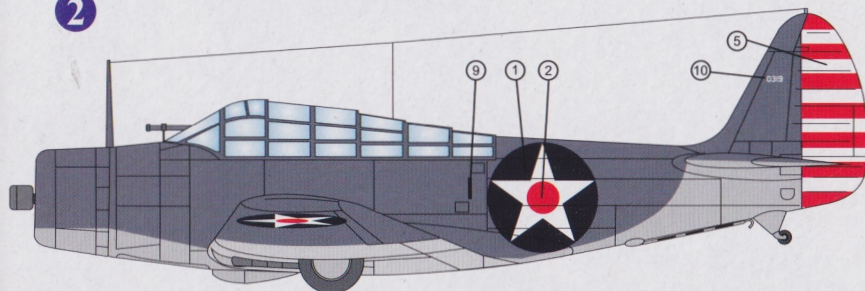

TBD - 1 „Devastator”, BuNo. 0319, „1” of VT-5, USS Yorktown, March 1942
Aircraft flown by CO of VT-5 Lt Cdr J. Taylor and CRM H. S. Nobbs during Lae-Salamua strikes in March 1942. Lt Cdr Taylor flew this aircraft also during the attack against Japanese carriers Shoho and Shokaku during the Coral Sea battle.

3

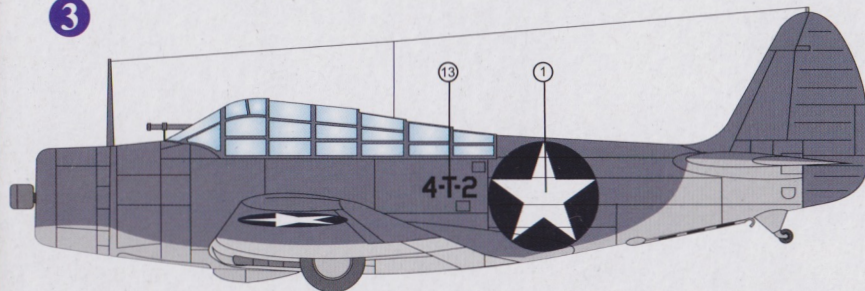

TBD - 1 „Devastator”, 4-T-2 of CV-4, USS Ranger, 1942
USS Ranger was not supposed to operate torpedo aircraft and only thanks to wartime needs there was a small unit of TBD's aboard, usually up to eight planes. 4-T-2 is one of them.

125
Blue
Grey

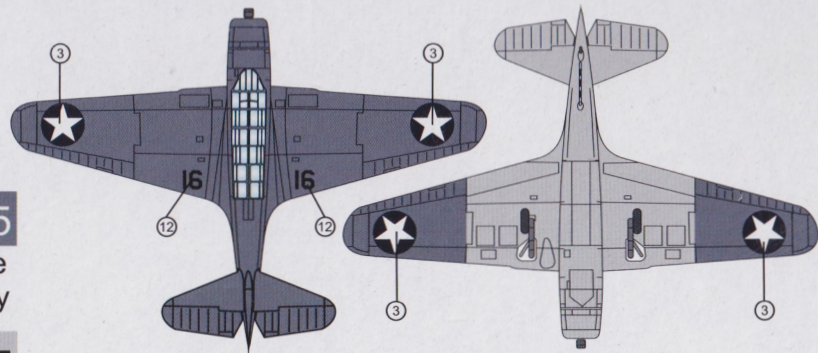

127
Medium
Grey

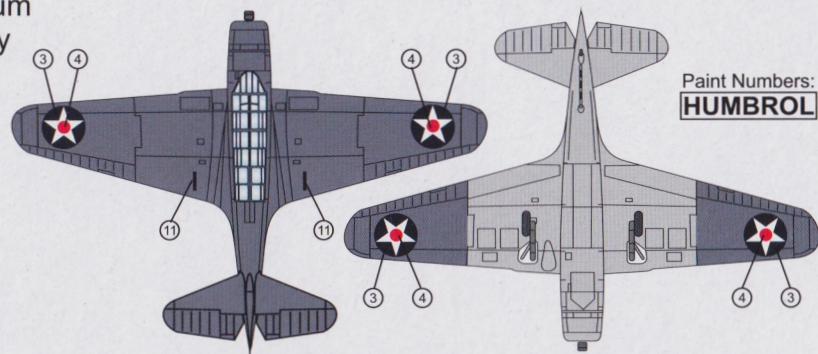

Paint Numbers:
HUMBROL

