

## SS-100 Gigant

**GB**

In 1936 Hanomag Company started the production of SSA-100 heavy cargo tractor. Compared to the that time cargo trucks SSA-100 was capable of towing two trailers with overall weight of 20 tons at overall speed 40 kmh. Compared to towing with similar vehicle this solution was almost half cheaper. Hanomag Company started to produce modified version SS-100 Gigant the very next year. Even though, the successful tractor found its users in civilian market when Wehrmacht begun to re equip itself, and mainly with the beginning of World War 2 all new vehicles were delivered intended for military use. SS-100 was widely used. It was deployed by Wehrmacht's engineering and transport units for heavy payload transport but by Luftwaffe units, too. Luftwaffe also used it for towing large aircraft, heavy bombs or mines, etc. The need of the tractors was so big that license production had to be started at Fross-Büssing Company from Vienna. Even with the end of the war the production did not stop. Conversely to the latter the production after the war gradually diverged as the Allied bomb damages were gradually repaired (thankfully Hanomag Company damage was minor). In total 1112 SS-100 tractors were produced from summer 1945 until the termination of the production in 1950 for civilian market, once again. The tractors captured during and after the war were used by other armies.

SS-100 design featured frame made from extruded "U" profiles, solid axles were suspended by leaf springs with the rear ones strengthened. The power plant D 85S, a six cylinder diesel engine with 8,553 cm3 volume gave output of 100 Hp. The engine featured dry multi-plate clutch with direct sequencing, four speed ZF transmission. Depending on the equipment the overall weight ranged from 5,000 to 6,600 Kg. With 250 litres of diesel in fuel tank located behind the cabin and the fuel consumption of 50 litres per 100 km the tractor was supposed to travel 500 km on one fuel filling.

**CZ**

Firma Hanomag vyrobila v roce 1936 těžký nákladní tahač SSA-100. Oproti tehdejším nákladním vozidlům byl schopen vleku i dvou návěsů o celkové váze až 20 tun při rychlosti 40 km/h. To bylo až o polovinu levnější než při použití jiného srovnatelného vozidla. Hned další rok začala firma Hanomag vyrábět vylepšenou verzi SS-100 Gigant. Úspěšný tahač našel uplatnění na civilním trhu, ale s vyzbrojováním Wehrmachtu a zejména s vypuknutím války byly další dodávky vojenské. Použití SS-100 bylo velmi široké. Do výzbroje ho zařadily k přepravě těžkých nákladů ženijní a transportní jednotky Wehrmachtu i jednotky Luftwaffe. U Luftwaffe sloužil i jako tahač větších letadel, jako transportní prostředek těžkých bomb či min apod. Potřeba tahačů byla taková, že se rozeběhla i licenční výroba u firmy Fross-Büssing ve Vídni. S ukončením války ale výroba tahačů SS-100 neskončila. Naopak se postupně rozbíhala, jak byly odstraňovány škody po spojeneckém bombardování (které naštěstí pro firmu Hanomag nebyly velké). Do úplného ukončení výroby tohoto typu v roce 1950, bylo od léta 1945 vyrobeno 1112 tahačů SS-100 opět pro civilní trh. Stroje ukořistěné během války se dostaly do výzbroje i jiných armád.

SS-100 měl rám z lisovaných "U" profilů, pevné nápravy zavěšené na listových perech, zadní pera byla zesílená. Šestiválcový dieselový motor D 85S o obsahu 8 553 cm3 měl výkon 100 koní. Motor měl vícelamelovou suchou spojku a čtyřrychlostní převodovku ZF s přímým řazením. Celková váha tahače byla 5000 6600 kg dle vybavení. Spotřeba nafty 50 litrů na 100 km a nádrž o obsahu 250 litrů umístěná za kabinou umožňovaly vozidlu dojezd 500 km na jedno natankování.

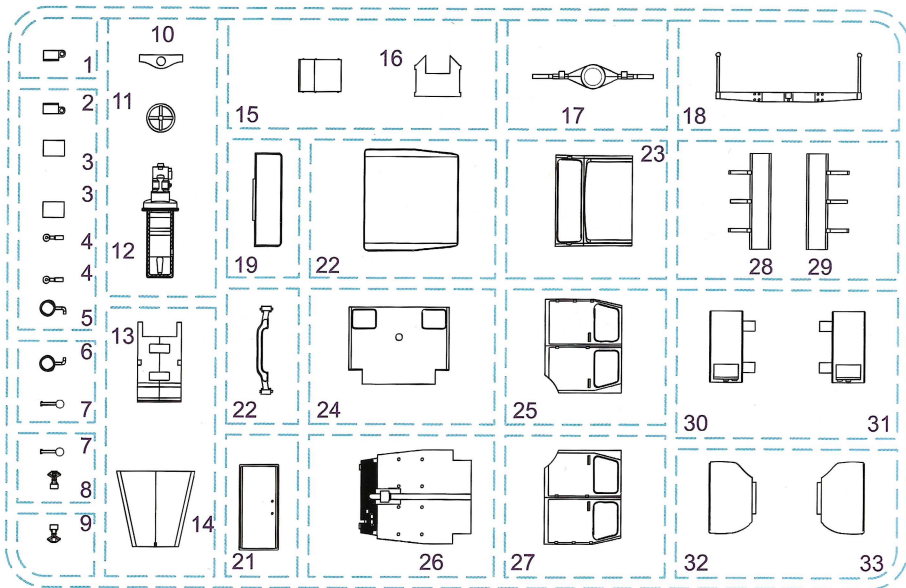
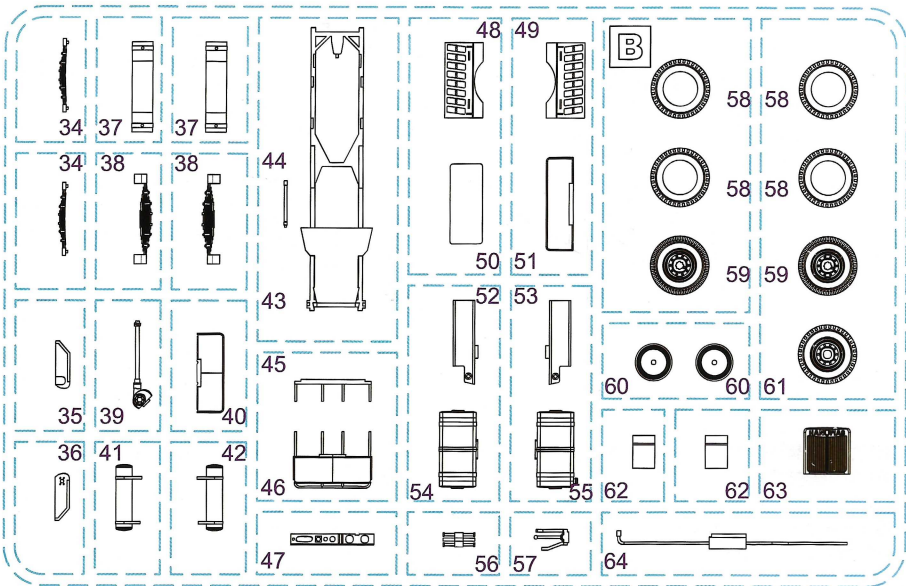
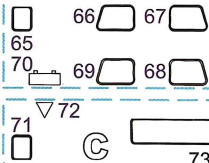
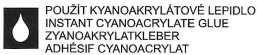
**A****B****SYMBOLS****C**

1

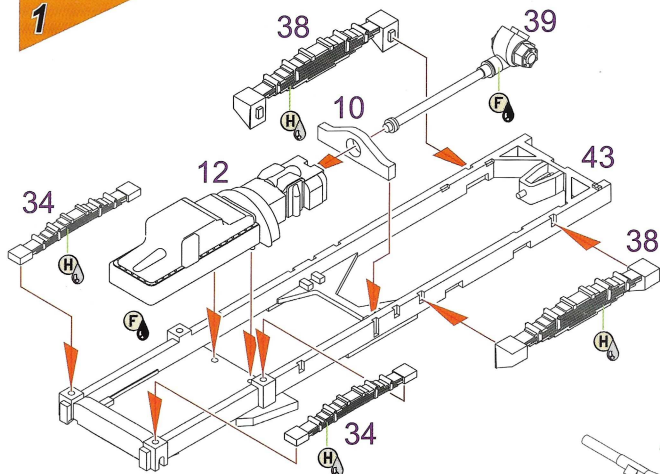

Barvy GUNZE/ GUNZE Colour No.		
A	Tanková šedá/ Tank Grey	H32/ C40
B	Tmavá žlutá/ Dark Yellow	H79/ C39
C	Cervenohnědá/ Red Brown	H47/ C41
D	Olivově zelená/ Olive Green	H420/ C120
E	Bílá matná/ Matt White	H11/ C62
F	Černá matná/ Matt Black	H12/ C33
G	Barva pneumatik/ Tire Black	H77/ C137
H	Ocel/ Steel	H18/ C28

2

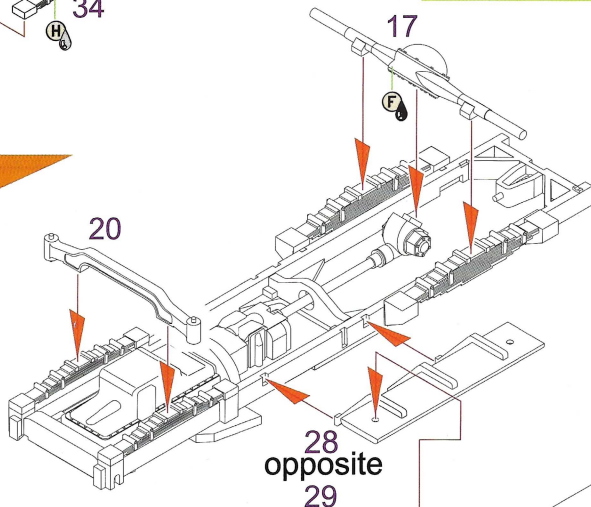

3

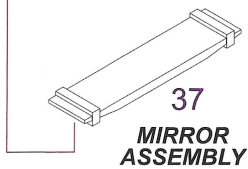
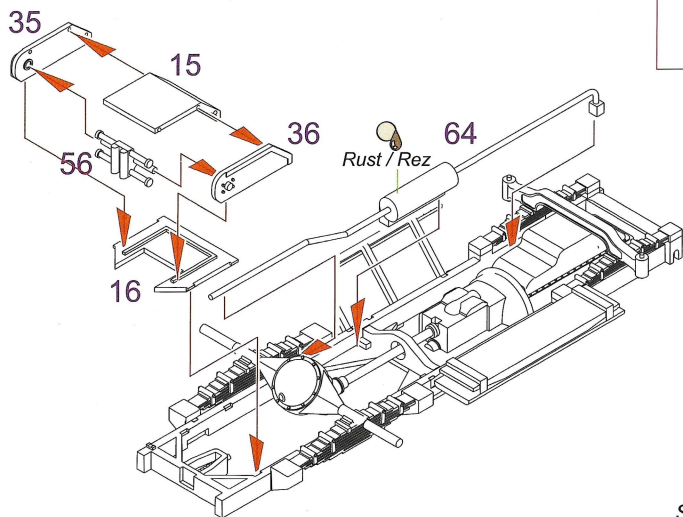

4

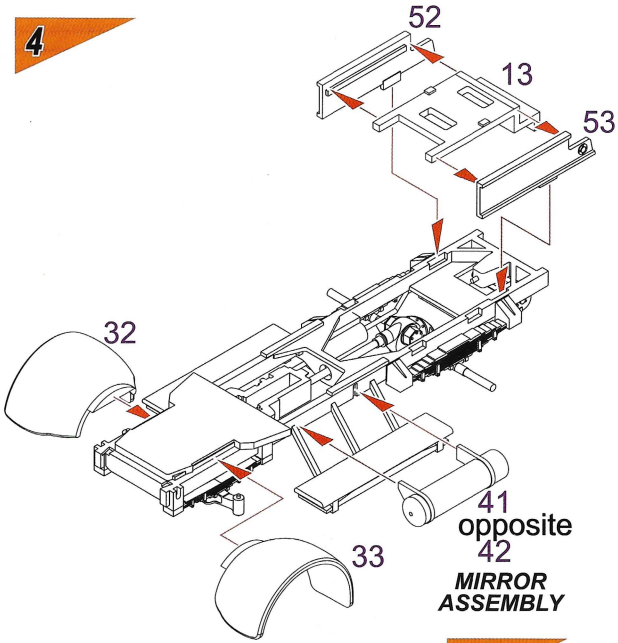

opposite  
42  
**MIRROR  
ASSEMBLY**

5

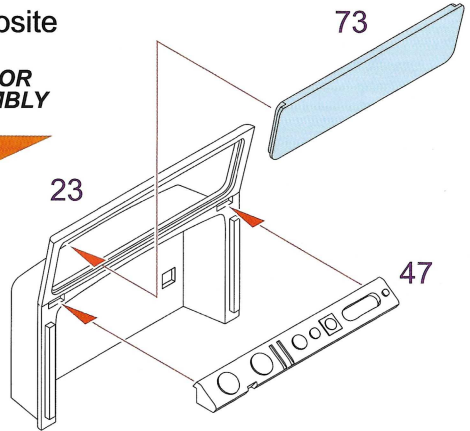

6

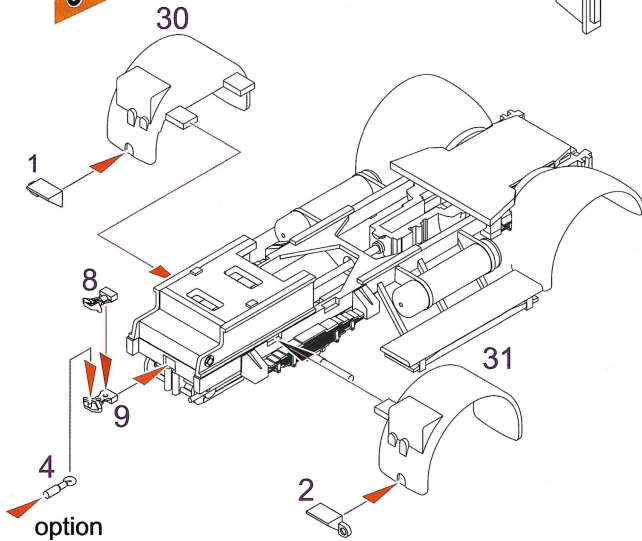

option  
(for example -  
Vidalwagen)

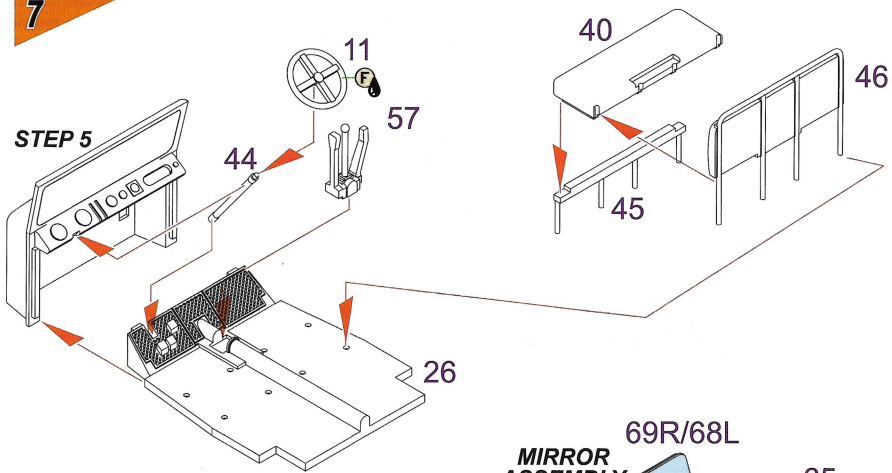
**7**

**Notes on coloring Interior:**  
 the basic colour of the interior cabin:  
 Tank Grey (cam. A)  
 Dark Yellow (cam. B, C);  
 the seat has been in skin color

**Zbarvení interiéru kabiny:**  
 základní barva interiéru:  
 Tanková šedá (cam. A)  
 Tmavě žlutá (cam. B, C);  
 sedačky byly v barvě kůže

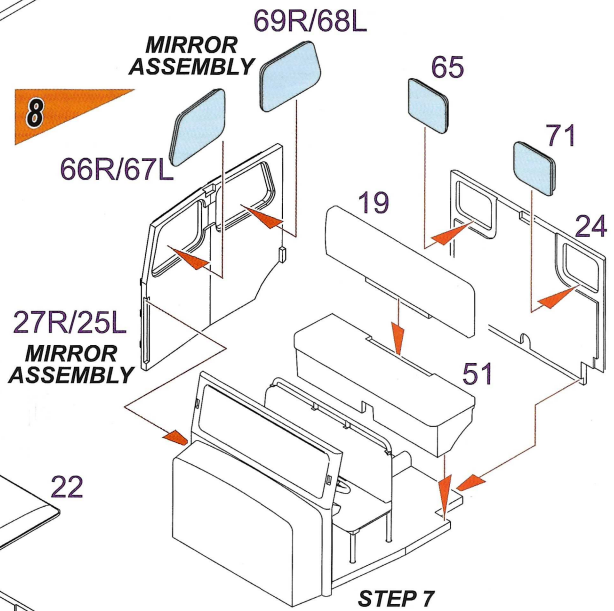
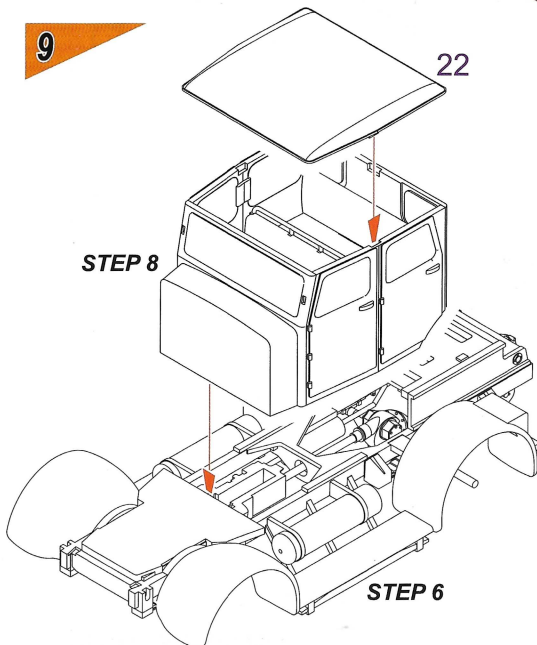
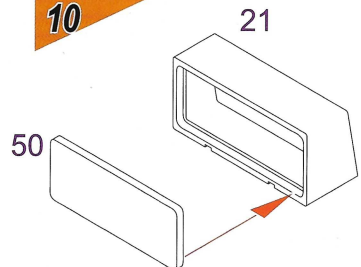
**8****9****10**

**11**

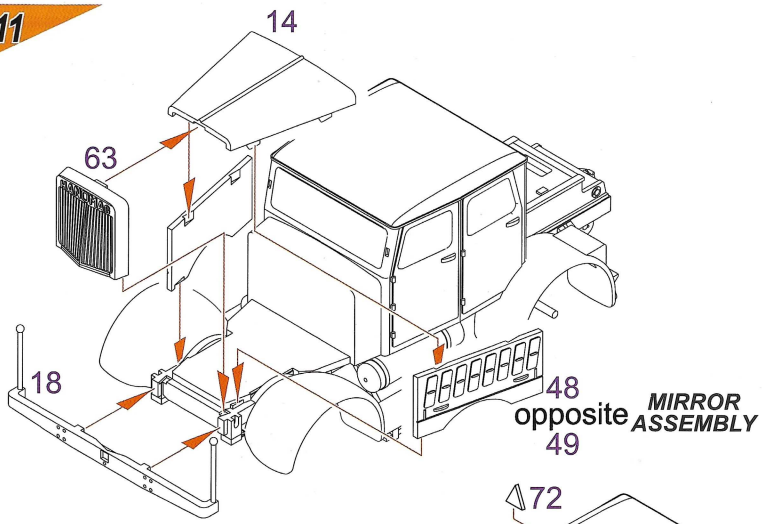

**12**

*Note:*  
Part 72 camo A,B only.

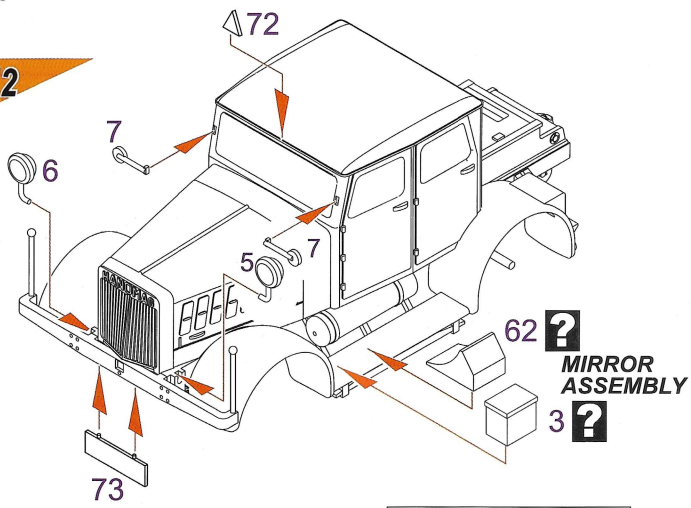

**13**

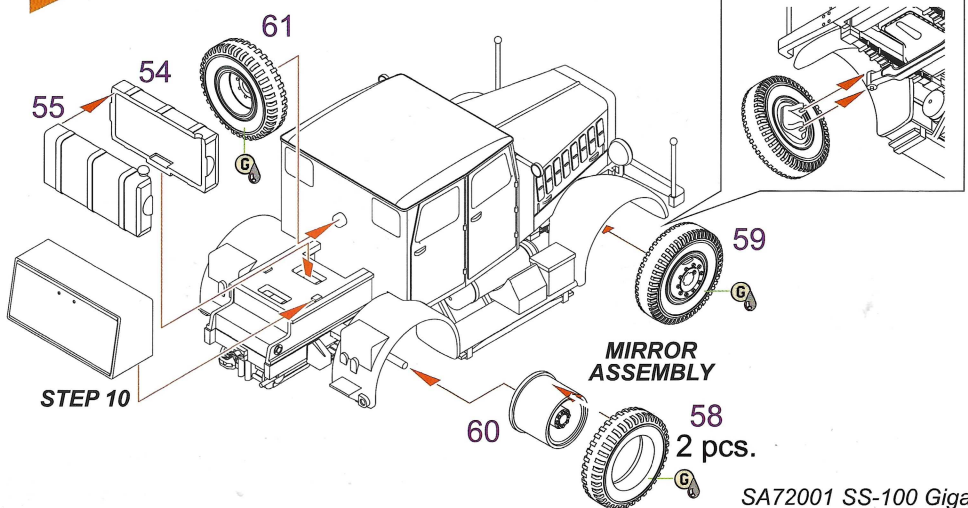

STEP 10

SS-100 Gigant, WL 94831, 5.rota / II.Abteilung / Luftnachrichten Regiment 21 Luftwaffe, oblast Achtyrka, Východní fronta, 1942. S vozidlem jezdil Gefreiter R. Gaura.

SS-100 Gigant, WL 94831, 5.Kompanie / II. Abteilung / Luftnachrichten Regiment 21 Luftwaffe, Akhtyrka district, Eastern Front, 1942. Gefreiter R.Gaura used to drive this vehicle.

**CAM. A**

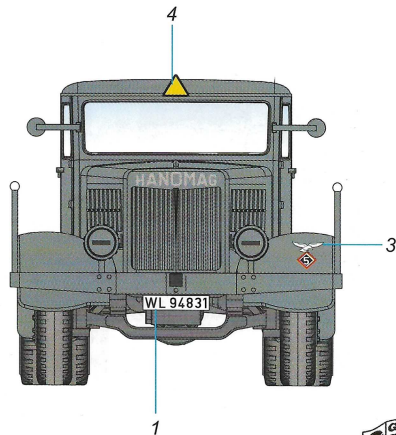
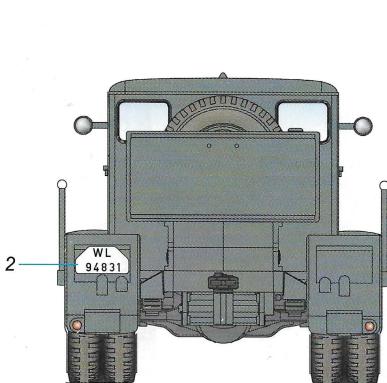
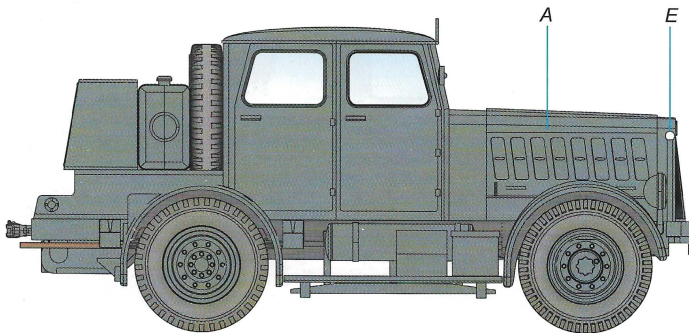
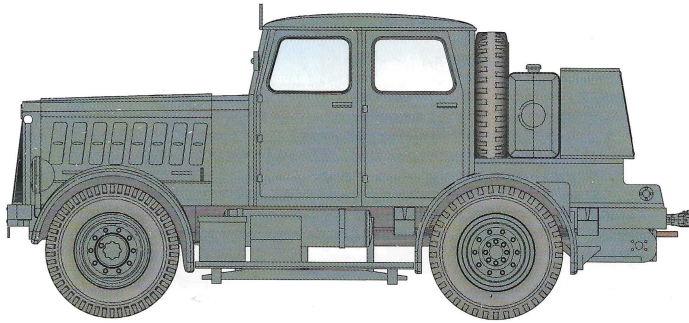

**A** Tanková šedá  
Tank Grey  
H32 / C40

**B** Tmavě žlutá  
Dark Yellow  
H79 / C39

**C** Červenohnědá  
Red Brown  
H47 / C41

**D** Olivově zelená  
Olive Green  
H420 / C120

**E** Bílá matná  
Matt White  
H11 / C62

**F** Černá matná  
Matt Black  
H12 / C33



SS-100 Gigant, WL 4744, přejímací jednotka  
Luftwaffe, umístěná na továrním letišti firmy  
Messerschmitt, Regensburg, 1944.

SS-100 Gigant, WL 4744, Luftwaffe acceptance  
unit, Messerschmitt factory airfield, Regensburg,  
1944.

**CAM. B**

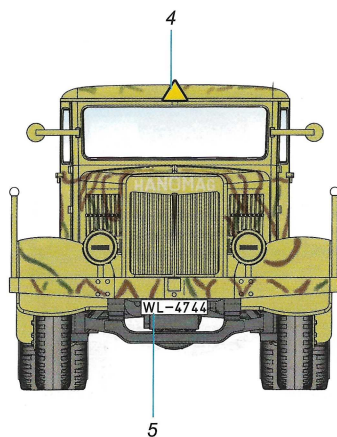
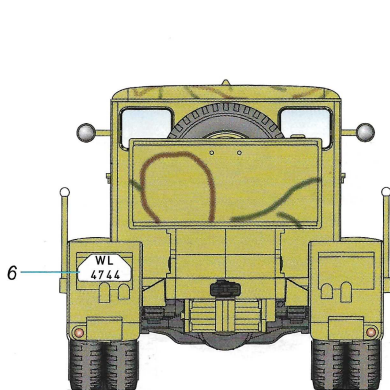
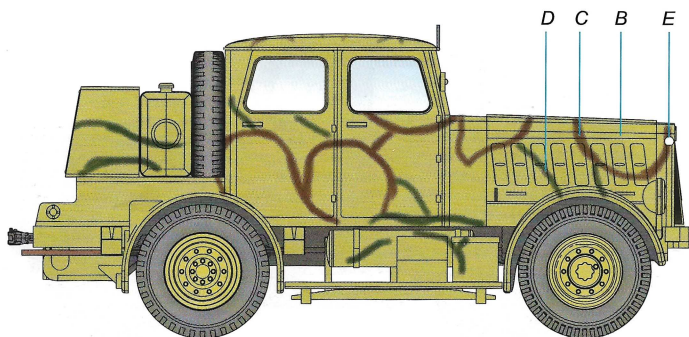
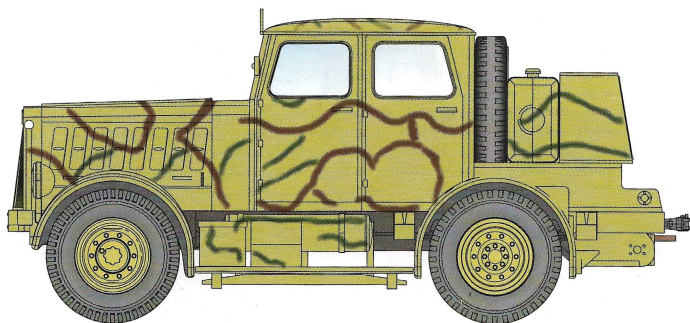

**A** Tanková šedá  
Tank Grey  
H32 / C40

**B** Tmavě žlutá  
Dark Yellow  
H79 / C39

**C** Červenohnědá  
Red Brown  
H47 / C41

**D** Olivově zelená  
Olive Green  
H420 / C120

**E** Bílá matná  
Matt White  
H11 / C62

**F** Černá matná  
Matt Black  
H12 / C33



**SA72001 SS-100 Gigant**



SS-100 Gigant, Wehr 545585, používaný ve středisku Peenemünde k tahání střel V2, 1944-45.

SS-100 Gigant, Wehr 545585, used at the Army Research Center, Peenemünde, for towing the V2 ballistic missiles, 1944-45.

**CAM. C**

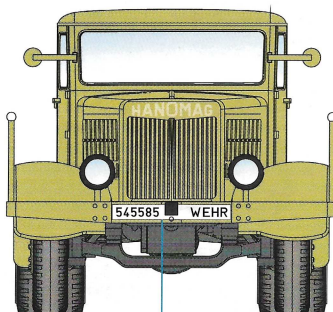
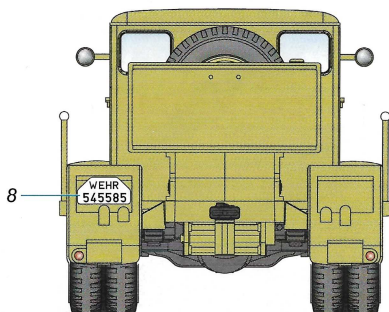
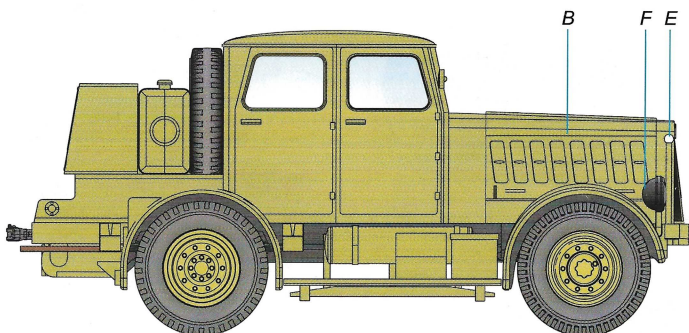
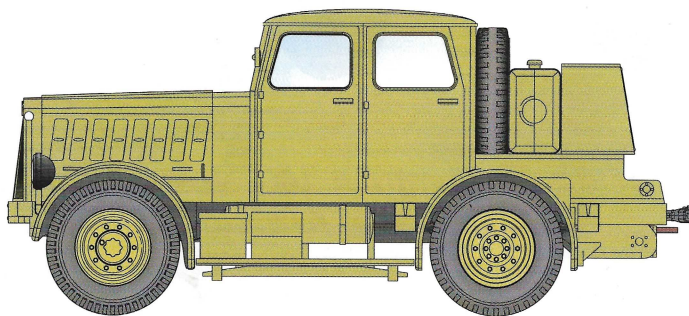

**A** Tanková šedá  
Tank Grey  
H32 / C40

**B** Tmavě žlutá  
Dark Yellow  
H79 / C39

**C** Červenoohnědá  
Red Brown  
H47 / C41

**D** Olivově zelená  
Olive Green  
H420 / C120

**E** Bílá matná  
Matt White  
H11 / C62

**F** Černá matná  
Matt Black  
H12 / C33



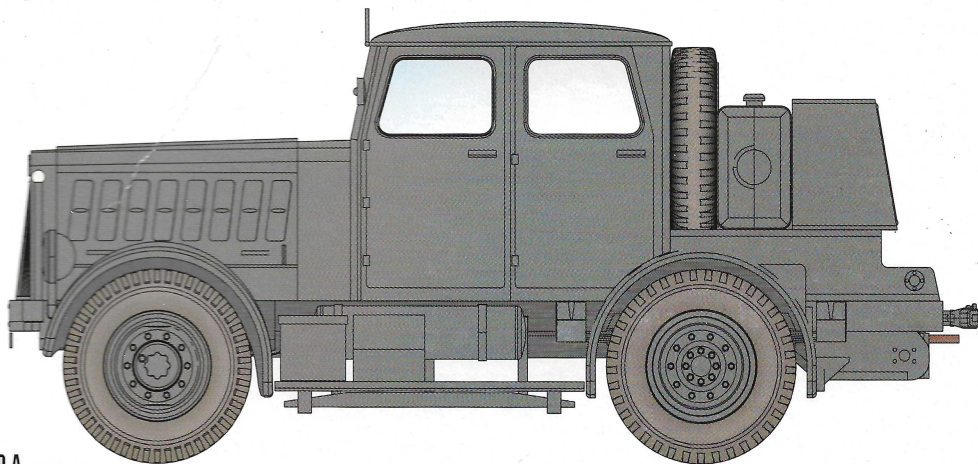

#### CAMO A

SS-100 Gigant, WL 94831, 5. rota / II. Abteilung / Luftnachrichten Regiment 21 Luftwaffe, oblast Achtyrka, Východní fronta, 1942. S vozidlem jezdil Gefreiter R. Gaura.

SS-100 Gigant, WL 94831, 5. Kompanie / II. Abteilung / Luftnachrichten Regiment 21 Luftwaffe, Akhtyrka district, Eastern Front, 1942. Gefreiter R. Gaura used to drive this vehicle.

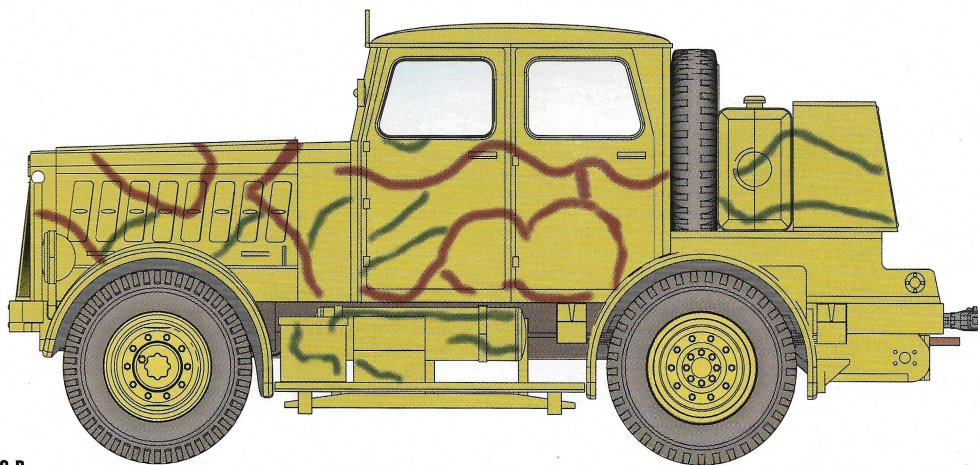

#### CAMO B

SS-100 Gigant, WL 4744, přejímací jednotka Luftwaffe, umístěná na továrním letišti firmy Messerschmitt, Regensburg, 1944.

SS-100 Gigant, WL 4744, Luftwaffe acceptance unit, Messerschmitt factory airfield, Regensburg, 1944.

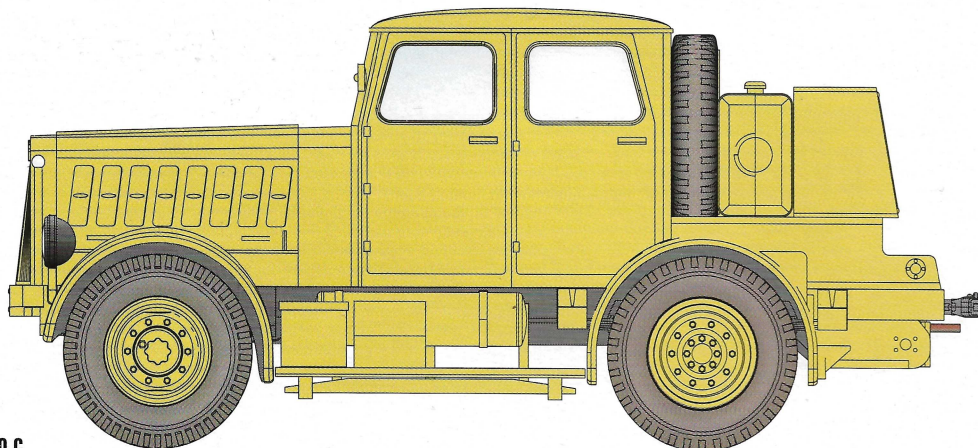

#### CAMO C

SS-100 Gigant, Wehr 545585, používaný ve středisku Peenemünde k tahání střel V2, 1944-45.

SS-100 Gigant, Wehr 545585, used at the Army Research Center, Peenemünde, for towing the V2 ballistic missiles, 1944-45.