

MIKOYAN GUREVICH MIG-17D/E FRESCO



1/72 Scale Series Kit No. JS-083

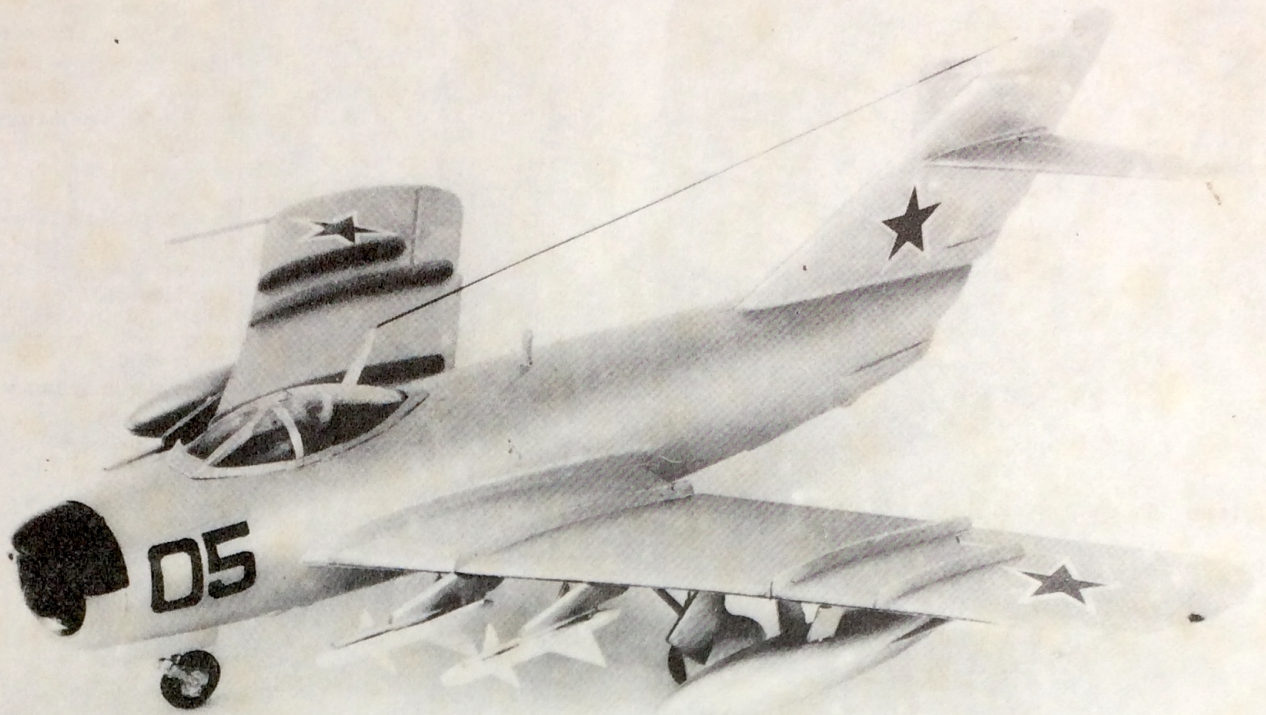

Photo of Completed Model

MIG-17 D/E

Utilizing the accumulated data during the Second World War, the famous MIG-15 was the world's first sweptback fighter plane to be perfected and became the rival to the F-86. However, due to the focus on the lightweight fuselage, it lacked the armament suitable to such a modern fighter plane. MIG-17 was developed as the successor of MIG-15. It was put into mass production from the latter part of 1952 and in 1953 it was assigned to the fighter squadrons, and subsequently advanced models were developed. They became the standard fighter planes for the Communist countries... production licensed to Czechoslovakia, Poland and Red China. Today, the countries operating the MIG-17 are USSR, Red China, Czechoslovakia, East European countries, Near East and African countries. The original MIG-15, through numerous improvements, became stable when landing and during takeoff at low speed, which fully performed to its expectation. MIG-15UTI, the widely used advanced training plane, is the evidence of the improvements. However, the high speed stability in the subsonic flight could not be solved. It was reported that there were many occasions the plane went into a spin during the tip stall, and therefore the U.S. did not give its approval due to such condition. MIG-17 was developed with the major aim in correcting the stability at high speed. The sweptback wing was increased to 45° and the wing became much thinner. The tip was extended into a bow shape and the boundary layer fence was increased to three. There is no major placement on the fuselage and tail wing in comparison to the main wing. According to the outer appearance, the back of the fuselage is somewhat extended and the overall shape of the fuselage became thinner, with the fin on the back and bottom of the fuselage and the width of the horizontal stabilizer became larger. The flap is now in one unit, divided into 2-inside and outside. Because the fuselage was extended, the back fitting on the main wing was also extended. The shape is quite different in comparison with the MIG-15 and it is fitted with one unit variation flap. MIG-17 Fresco is classified from A to E. Fresco D is the limited all weather type, the nose extended, radar dome in the middle of the air intake, and the range finder radar antenna on the top of the nose tip. The overall length of the fuselage on

this model is 0.6m (12.2m longer than the A, B, C Models.) Since the cockpit is equipped with Scoup, the space becomes much larger, which changes the outer shape. Automatic cannon is the same as Model C. The fuselage on Fresco E is the same as Model D, and is also a limited all weather type, by removing the automatic cannon armament and replaced with four small beam radar anti-aircraft missiles, and pylon on the front of the main wing.

MIG-17 D/E Data

Engine: Klimov VK-1F / Thrust: 2,695kg., with afterburner 3,300kg. (3,450kg. on planes produced later) / Overall Width: 9.6m / Overall Length: 12.2m / Overall Height: 3.8m / Main Wing Area: 24.6m² / Dead Weight: 4,470kg. / Rate of Climb from Sea Level: 3,240m per min. / Max. Speed: Mach 0.97 / Service Ceiling: 16,700m / Cruising Range: 440nm / Armament: Model D ... 37mm cannon x 1, 23mm cannon x 2, bomb 500kg. Model E ... Automatic cannon removed and replaced with 4 missiles.

Afterburner

This is the booster to increase the jet engine thrust. The gas, passing through the turbine fins, with the remaining oxygen is reburned by fuel injection. In this case there is not limitation on the fin gas compared to the gas temperature; therefore, to heat up the gas temperature the injection speed becomes higher to increase the thrust. However, by this method the fuel consumption ratio is great, and not economical for regular flight.

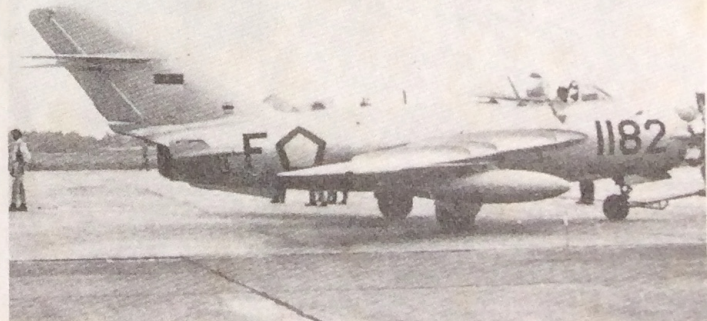
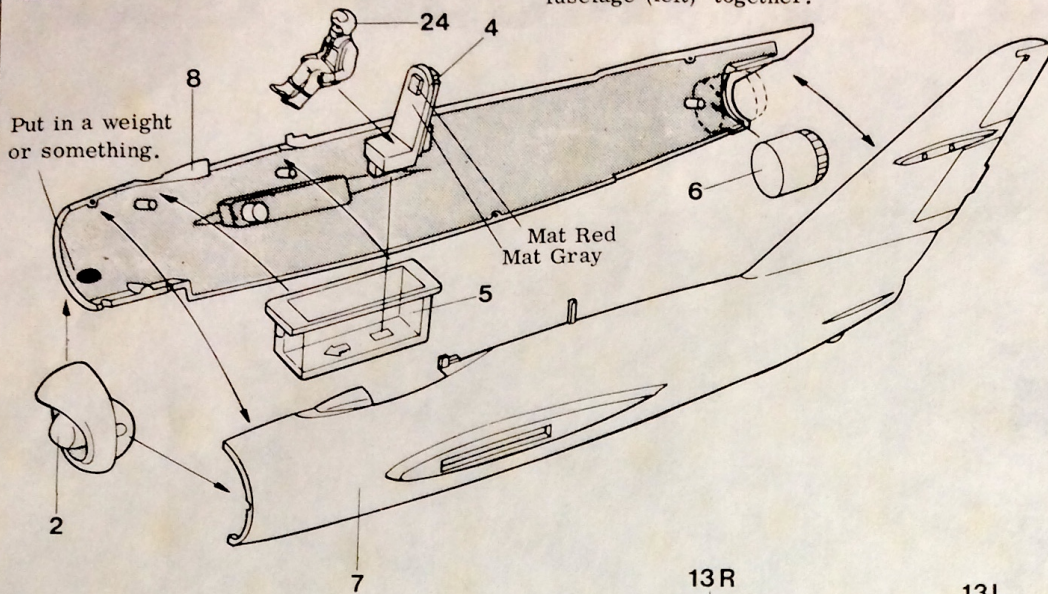

Photo offered by Aircraft News Service

1 Fuselage Assembly

Cement the assembled cockpit to the fuselage (right) and cement the fuselage (left) together.



2 Wing Assembly

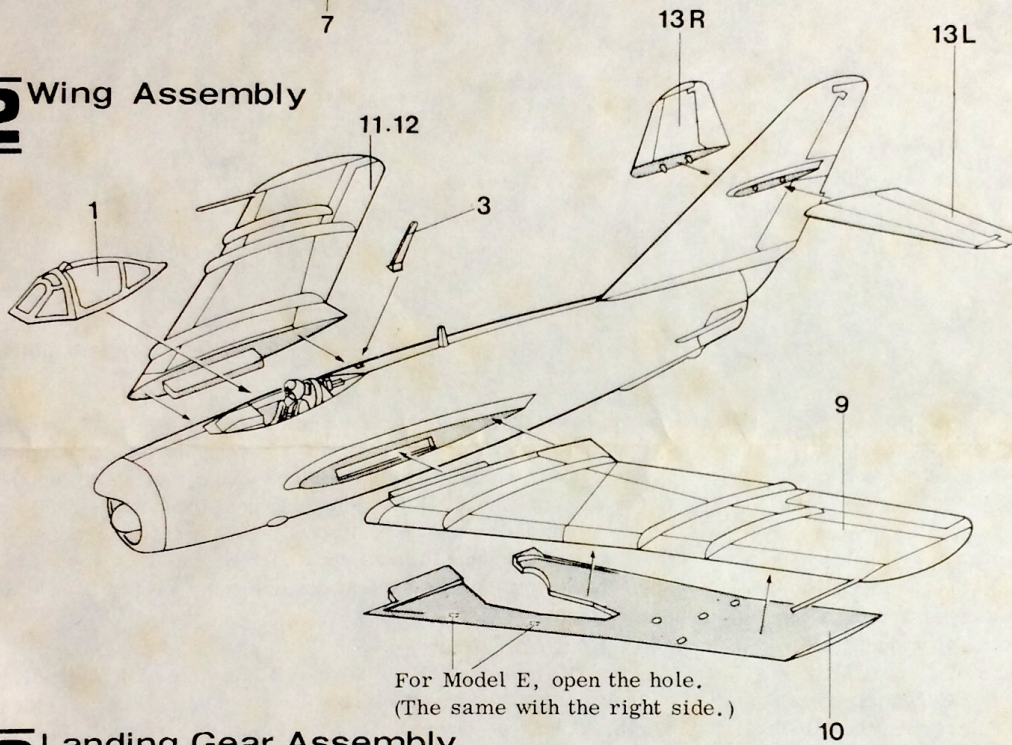

3 Landing Gear Assembly

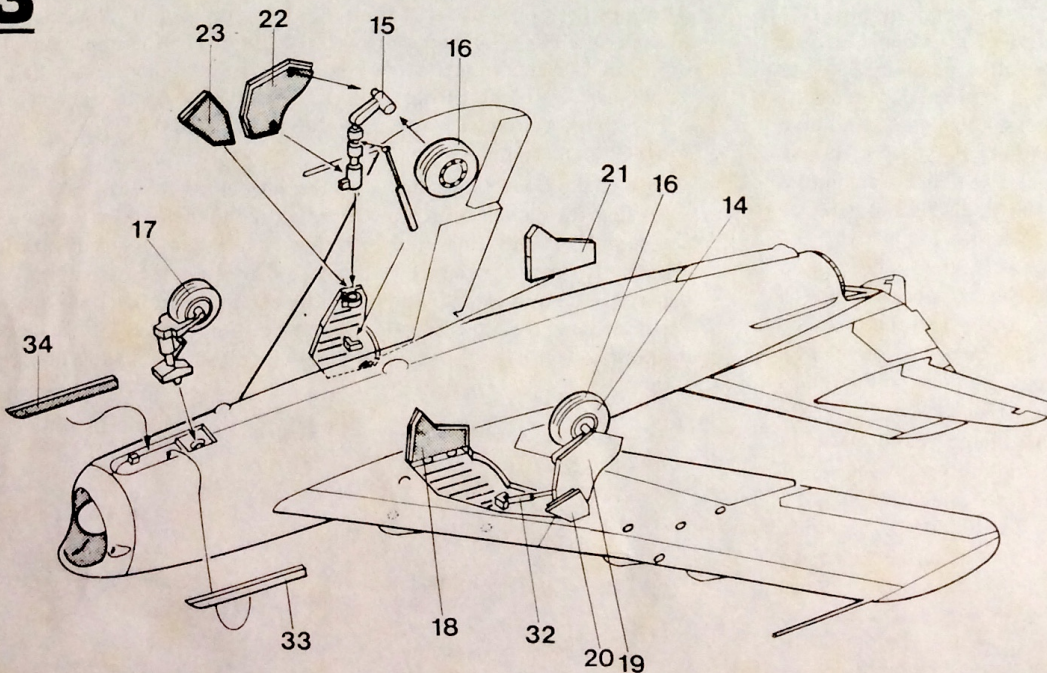

Read This before Assembly

- * Carefully read the instructions before assembling your model, and follow the instructions.
- * Carefully cut off the parts from the stem with a knife or clipper.

Model Color

The model colors are from (1) - (60). After the model is assembled, be sure to paint it.

Note:

After removing the parts from the bag, cut it in pieces and throw it away to prevent the infant from covering its head.

- Precaution in handling the adhesive.
 1. Keep it away from infants, and do not use it other than for cementing.
 2. Keep away from fire.
 3. Do not deliberately inhale it.

* Drawing-1

After the pilot is painted, cement it to the seat.

Paint the cockpit by properly using the light and dark gray.

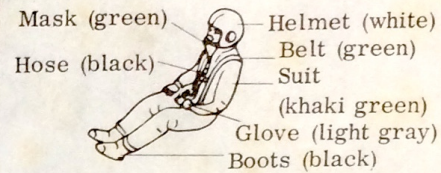

* Drawing-2

This is a convertible kit to assemble Model D or Model E. For Model E, open the designated holes on the main wing bottom (10), (11).

Canopy (1) framework is painted in silver, the same color as the fuselage.

* Landing Gear Fitting Reference Drawing (seen from the front)

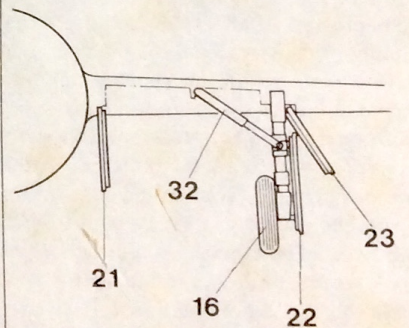

Be sure to fit on the landing gear strut and wheel cover (left and right) on the correct side. Paint the inside of cover in gray.

4 Parts Fitting

Model D

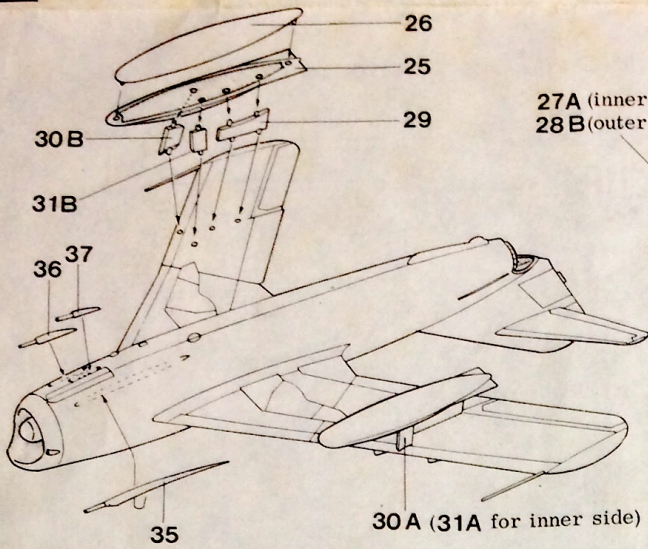

* Reference Drawing to fit on the automatic cannon.

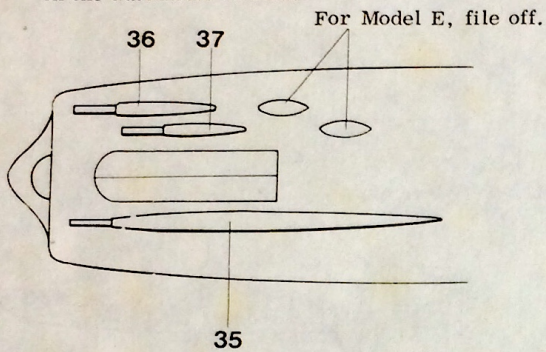

Model E

27A (inner side)
28B (outer side)

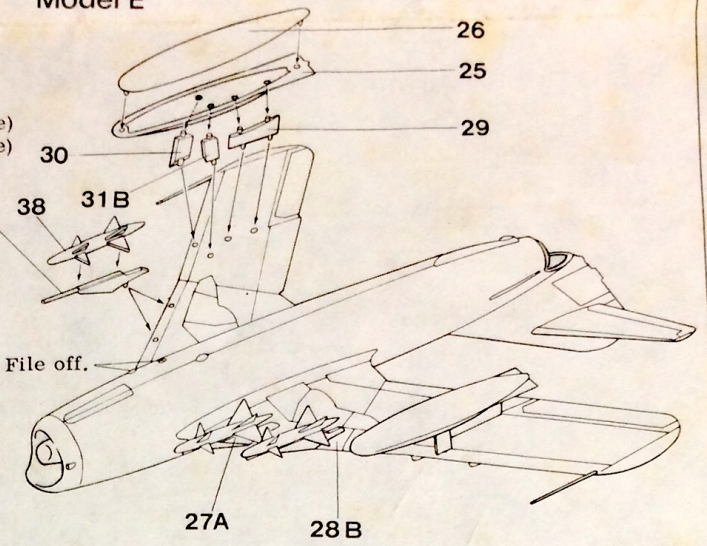

* Reference Drawing for missile fitting. (seen from the front)

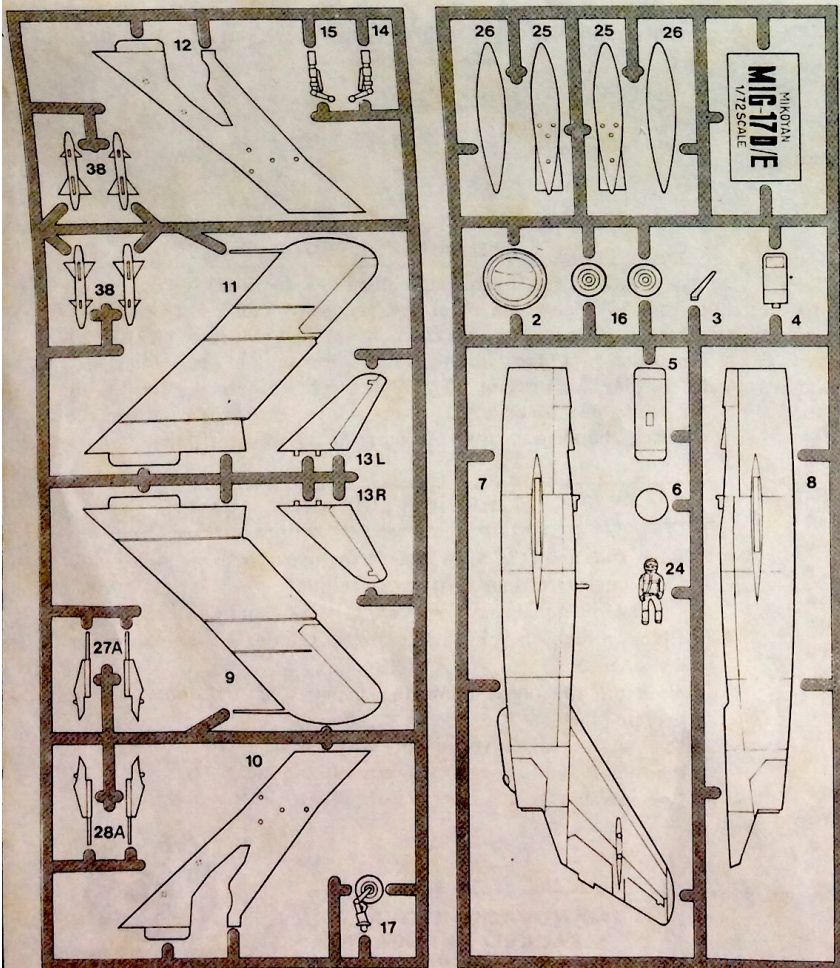
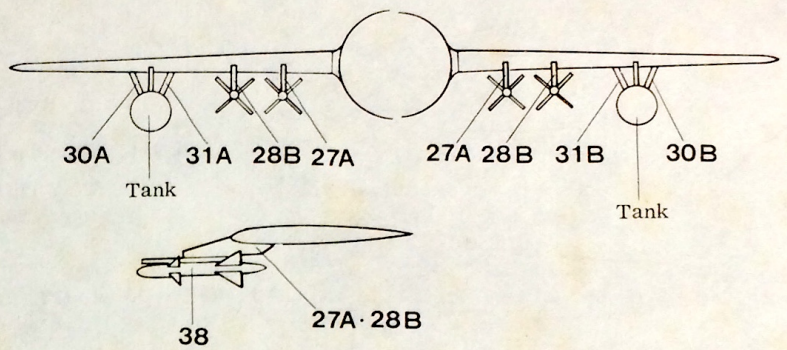

Parts

- | | |
|-----------------------------------|------------------------------------|
| 1. Canopy | 21. Landing Wheel Cover |
| 2. Nose Radar Dome | 22. Landing Gear Cover (A) |
| 3. Antenna Strut | 23. Landing Gear Cover (B) |
| 4. Seat | 24. Pilot |
| 5. Cockpit | 25. Tank, bottom |
| 6. Exhaust Outlet | 26. Tank, top |
| 7. Fuselage (left) | 27A. Missile Pylon (inner side) |
| 8. Fuselage (right) | 28B. Missile Pylon (outer side) |
| 9. Main Wing, top (left) | 29. Tank Pylon |
| 10. Main Wing, bottom (left) | 30A. Tank Strut (right outer side) |
| 11. Main Wing, top (right) | 30B. Tank Strut (left outer side) |
| 12. Main Wing, bottom (right) | 31A. Tank Strut (right inner side) |
| 13L. Horizontal Tailwing (left) | 31B. Tank Strut (left inner side) |
| 13R. Horizontal Tail wing (right) | 32. Landing Gear Strut |
| 14. Landing Gear Strut (right) | 33. Nose Wheel Cover (left) |
| 15. Landing Gear Strut (left) | 34. Nose Wheel Cover (right) |
| 16. Landing Wheel | 35. Automatic Cannon (A) |
| 17. Nose Wheel | 36. Automatic Cannon (B) |
| 18. Landing Wheel Cover | 37. Automatic Cannon (C) |
| 19. Landing Gear Cover (A) | 38. Missile |
| 20. Landing Gear Cover (B) | |

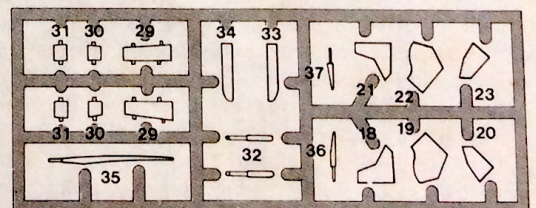

Marking & Color Painting Guide

MIG-17E USSR Airforce

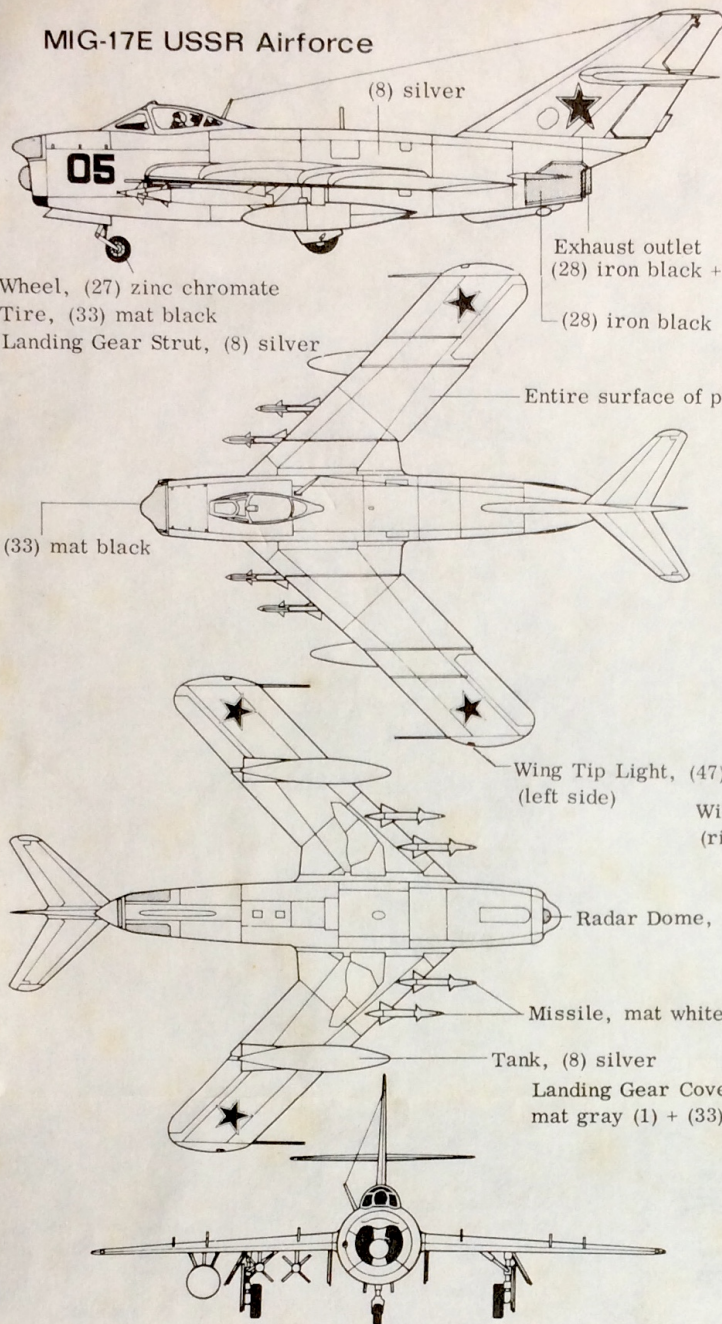

Wheel, (27) zinc chromate
Tire, (33) mat black
Landing Gear Strut, (8) silver

Exhaust outlet (33) mat black
(28) iron black + (10) copper

(28) iron black

Entire surface of plane, (8) silver

(33) mat black

Wing Tip Light, (47) clear red
(left side)

Wing Tip Light, (50) clear blue
(right side)

Radar Dome, (33) mat black

Missile, mat white (1) + (30)

Tank, (8) silver

Landing Gear Cover (inner side),
mat gray (1) + (33) + dab of green

Antenna Wire

MIG-17 D/E Painting

The MIG-17 is almost colorless (original metallic surface). To remove the reflection on the nose it is painted in black or in dark green. The radar dome is painted in black or in whitish color. The rear exhaust outlet is painted in iron black and the heat resistance rime around the exhaust outlet in burnt black. The interior of the plane and the landing gear are painted in gray, and the wheel in zinc chromate. The missiles are white, but painted in red for acrobatic performance.

For the model purpose, there are two methods in your painting. No.1, polish the surface with silver powder or silver paste to give a metallic finish. However, in this case do not touch the polished surface with the hand. To prevent the silver powder from rising, spray on the clear lacquer. No.2 method, make a blend color of different type of silver; silver mixed with black, white yellow or blue. Then use these properly in reference with the picture of the actual plane so that the blackish part is painted in the silver with black, and the whitish part, the silver with white. Paint the interior of the plane in mat gray, the instrument panel in mat black, the head rest in dark red. Paint the landing gear hatch in mat gray. For the antenna wire, heat the plastic stem and stretch it to a thin wire, or use a nylon thread. Put the decal at the proper position after the paint is well dried.

MIG-17D Czech Airforce

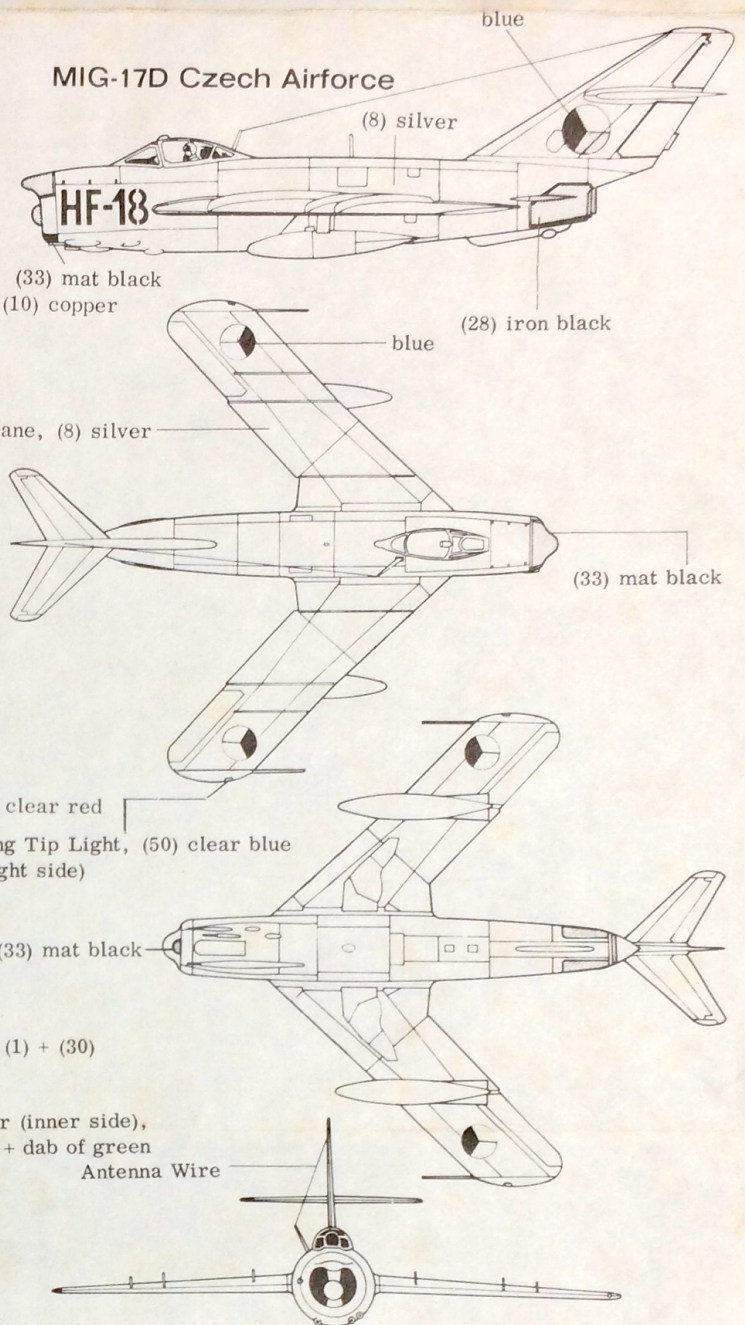

blue

(8) silver

(28) iron black

blue

(33) mat black

© Model Color

The numbers for the model colors are from (1) - (60). After the kit is assembled paint the necessary colors (1) white, (8) silver, (10) copper, (27) zinc chromate, (28) iron black, (30) flat base, (33) black (mat), (48) clear red, (50) clear blue, (51) flesh, (54) khaki green. To paint a wide area, use a flat brush; for pilots and other small parts use a thin brush. After the painting, be sure to wash the paint brush in paint thinner.

Applying Decals

1. Wipe and clean the area, where the decal is to be positioned, from dust or oiliness with a wet cloth.
2. Cut out the decal and remove the film covering.
3. Place in lukewarm water, transfer the decal when the paper becomes flat.
4. Slide off the decal from the paper and position it at the proper place.
5. Press the transferred decal with a soft cloth, to adhere to the model and to remove the excess moisture.
6. Do not touch the transferred decal until it is well dried.

MANUFACTURED IN JAPAN
& PACKED IN ENGLAND
By A. A. HALES LTD.
HINCKLEY, LEICS.

