

# Velveta / Spitfire for Israel

eduard

BRITISH WWII FIGHTER

1/48 SCALE PLASTIC KIT

#11111



## INTRO

In September 1941, a hitherto unknown German radial engine fighter appeared in the west European sky. The new airplane was superior to British fighters, most distressingly to the Spitfire Mk.V. The German design was soon recognized as the Focke-Wulf Fw 190 A. The losses suffered by the RAF over western Europe rose rapidly and the crisis was serious enough that the RAF ceased the majority of daytime operations in November, 1941. The next attempt to resume these types of sorties was made in March 1942. Loss rates remained unacceptably high and the RAF was forced to stop ops once again. All this was thanks to the Focke-Wulf Fw 190 A. The first response to the new German weapon was the Spitfire Mk.VIII, but the design changes were so complex that initiating timely production was not possible. In June, 1942, a German pilot landed by mistake on a British airfield delivering a completely intact Fw 190 fighter into RAF hands. Comparative trials between the Focke-Wulf and Spitfire Mk.V began almost immediately. These mock encounters confirmed the situation over the front – the chances of a British fighter surviving an encounter with the Fw 190 were slim. The only British fighter aircraft deemed suitable to oppose them were the Spitfire Mk.VII and VIII powered by the Merlin 61 engine. As mentioned above these were some time away of being ready for series production. But there was another way of getting a powerful fighter quickly - by mating the Merlin 61, with its two-stage supercharger, with the fuselage of the Spitfire Mk.Vc. Two Mk.Vc airframes, AB196 and AB197, were selected for this purpose and were strengthened with modified longerons to accommodate the more powerful and heavier engine. The example was finished on February 26 and the second on March 27, 1942. Flight trials were successful and the order for series production was issued almost immediately. Series production began in June 1942 and the first Mk.IXs found their way to No. 64 Squadron in July. Performance improved significantly in comparison to the Mk.V. A top speed of 409 mph at 28,000 feet was higher by 40mph, and the service ceiling rose from 36,200 to 43,000 feet. The Mk.IX could climb at 4,000 feet per minute. The RAF finally had a fighter aircraft capable of opposing the Fw 190 A. Three main versions of the Mk.IX were produced. The F.IX was powered by the Merlin 61 and was the only version on the assembly line in early 1943. The next version was the LF Mk.IX powered by the Merlin 66. This engine was designed to do its best at low altitudes. The third version, manufactured along with the LF, was the high-altitude HF Mk.IX with the Merlin 70. The majority of Mk.IXs manufactured were equipped with the so-called 'C' wing. Four 20mm cannon or two 20mm cannon and four .303 machine guns could be installed in the wings. From 1944, the strengthened 'E' wing was produced. Four .303 machine guns were replaced with two .50 heavy machine guns. Bomb racks for 250lb bombs were fitted under each wing typically. The Mk.IX became the second most numerous version of the Spitfire with a total of 5653 examples being built. The Mk.IX began to replace the Mk.V from June, 1942. Thanks to the new fighter, the RAF was ready to fight against the Luftwaffe over occupied Europe. Spitfire Mk.IXs served with the RAF to the end of war. In the postwar era, foreign air forces flew this version as well. Czechoslovak, Norwegian, Danish, and Canadian air forces operated numbers of Mk.IXs and they were not alone. Spitfires would find themselves in combat again. Czechoslovakia sold its Spitfire Mk.IXs to Israel in 1948 and these aircraft formed the backbone of the newly born Israeli air force in the fight against their Arab neighbours.

The Supermarine Spitfire Mk.IX was the first Israeli fighter aircraft with a truly significant combat capability allowing the pilots of the Cheyl Ha'Avir (Israeli Air Force) to swing the decisive battles fought against the Arab states in Israel's favour immediately after the formation of the nation in 1948-49. The pilots of what at the time was the only fighter squadron of the Israeli Air Force, the 101st Tajaset, scored 26 victories in all, fourteen of which are credited to the Spitfire. The enemy aircraft that were encountered included seven Macchi MC.205V and three Spitfires from the Egyptian Air Force along with three Spitfires and one Tempest of the Royal Air Force. As a comparison, the Avia S.199 was credited with six confirmed and one probable kill, and the Mustang five kills. Kills from the cockpits of Israeli aircraft were generally scored by foreign volunteers, known in Israel by the acronym MACHAL (Mitnadvei Chuc L'Arc) because at the time, Israel had a shortage of its own qualified pilots. Noteworthy among them were two Canadians, John Frederick McElroy, DFC & Bar, an ace with 14.5 kills to his credit from the Second World War and Joseph Doyle with two Second World War kills, and Chalmers H. Goodlin, who worked with Bell and was involved with the first supersonic aircraft, the Bell X-1. Another huge influence that the Spitfire brought with it to Israel was the ability to train the first generation of Israeli pilots. They flew the Spitfire, and in some cases went on to have remarkable careers in the Israeli Air Force, such as Ezer Weizman (Commander of the Israeli Air Force and future President), Dany Shapiro (long term Cheyl Ha' Avir test pilot and later with Israeli Aircraft Industries) and Modi Hod (another leader in the Israeli Air Force). In the years between 1948 and 1956, the Israeli Air Force saw the service of some ninety Spitfires Mk.IX of various subtypes. Aircraft numbered 2001 to 2090 have been documented. The most common of these have been the LF Mk.IXe. These were delivered to the tune of 62 aircraft from Czechoslovakia and the Cheyl Ha' Avir pressed into service, or at least recorded, 57. Other LF Mk.IXe aircraft came with several HF Mk.IXe or F Mk.IXc from a thirty plane delivery from Italy. Also pressed into service were two aircraft assembled from wrecks with wings from IXc aircraft. The aircraft built from wrecks were serialized 2001 and 2002, aircraft from Czechoslovakia 2003 to 2059, and the Italian aircraft 2060 to 2090. Some aircraft, such as 2090, never reached Cheyl Ha'Avir service and went directly from the depository to Burma in a thirty plane deal in 1954. In the Cheyl Ha'Avir, Spitfires first found their way to the 101st Tajaset in 1948, with which they fought in the War of Independence and served there until 1953 as trainers for Israeli pilots. In the trainer role, they were subsequently used by two other units, 105th Tajaset from 1950 until 1956 and 107th Tajaset in 1953/54. They served until 1956, when the last sixteen of the airworthy examples were retired. To this day, only twelve Spitfires that flew in Israel have been preserved. Some are even airworthy, while the rest are museum displays or are stored in various facilities around the world.

ATTENTION



UPOZORNĚNÍ



ACHTUNG



ATTENTION



注意



Carefully read instruction sheet before assembling. When you use glue or paint, do not use near open flame and use in well ventilated room. Keep out of reach of small children. Children must not be allowed to suck any part, or pull vinyl bag over the head.



Před započítím stavby si pečlivě prostudujte stavební návod. Při používání barev a lepidel pracujte v dobře větrané místnosti. Lepidla ani barvy nepoužívejte v blízkosti otevřeného ohně. Model není určen malým dětem, mohlo by dojít k požití drobných dílů.

INSTRUCTION SIGNS

\* INSTR. SYMBOLY

\* INSTRUKTION SINNBILDEN

\* SYMBOLES

\* 記号の説明

OPTIONAL  
VOLBABEND  
OHNOUTOPEN HOLE  
VYVRTAT OTVORSYMMETRICAL ASSEMBLY  
SYMETRICKÁ MONTÁŽREMOVE  
ODŘÍZNOUTREVERSE SIDE  
OTOČITAPPLY EDUARD MASK  
AND PAINT  
POUŽÍT EDUARD MASK  
NABARVIT

PARTS



DÍLY



TEILE



PIÈCES



部品

## PLASTIC PARTS

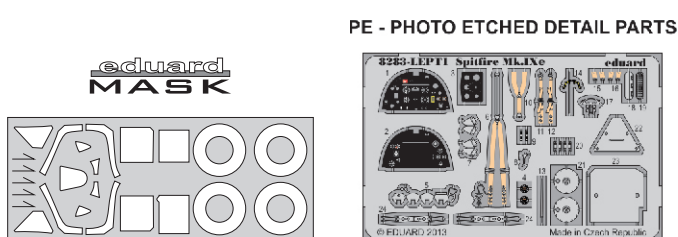
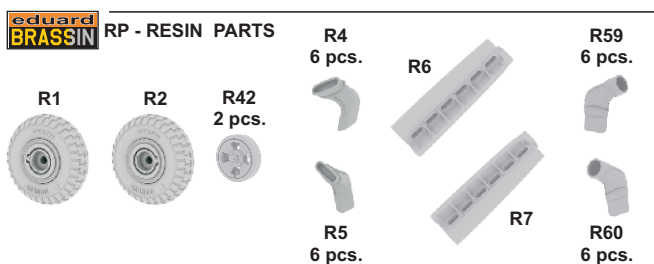
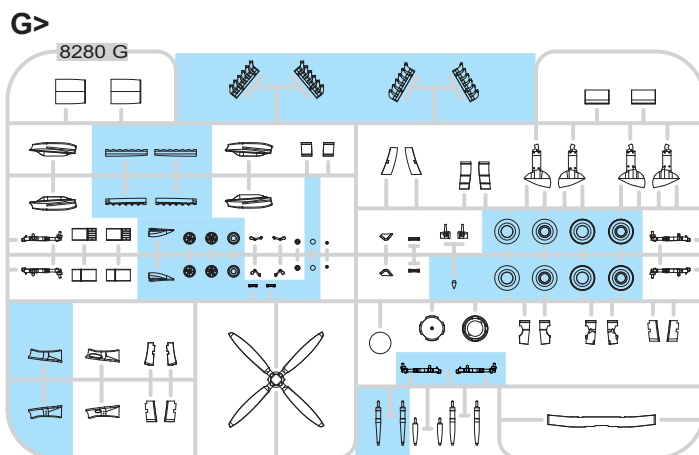
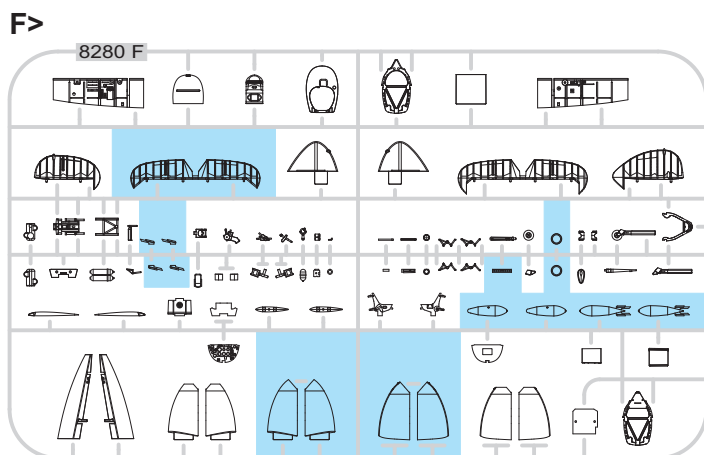
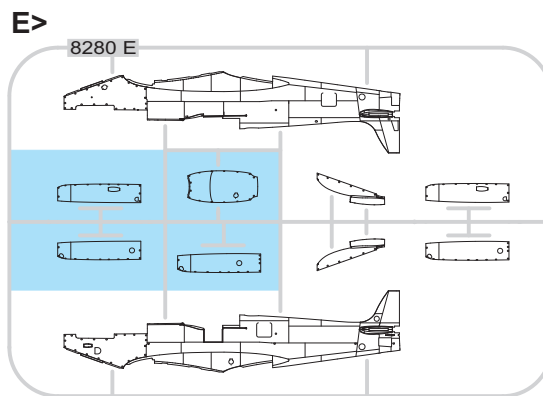
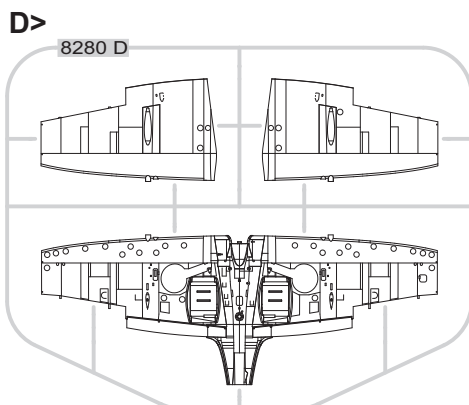
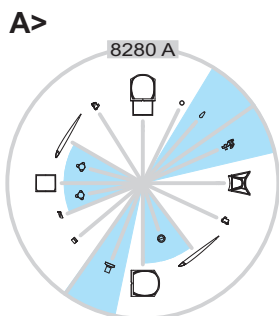

-Parts not for use. -Teile werden nicht verwendet. -Pièces à ne pas utiliser. -Tyto díly nepoužívejte při stavbě. - 使用しない部品

COLOURS



BARVY



FARBEN



PEINTURE



色

GSI Creos (GUNZE)		
AQUEOUS	Mr.COLOR	
H 2	C2	BLACK
H 4	C4	YELLOW
H 5	C5	BLUE
H 11	C62	WHITE
H 12	C33	FLAT BLACK
H 13	C3	FLAT RED
H 33	C81	RUSSET
H 51	C11	LIGHT GULL GRAY
H 72	C22	SAND
H 77	C137	TIRE BLACK
H 90	C47	CLEAR RED
H 94	C137	CLEAR GREEN

AQUEOUS	Mr.COLOR	
H 306	C306	LIGHT GRAY
H 308	C308	GRAY
H 326	C326	DARK BLUE
H 330	C361	DARK GREEN
H 335	C363	MEDIUM SEA GRAY
	C362	OCEAN GRAY
	C364	AIRCRAFT GRAY-GREEN
Mr.METAL COLOR		
MC214		DARK IRON
MC218		ALUMINIUM
Mr.COLOR SUPER METALLIC		
SM06		CHROME SILVER

**INTERIOR COLOR**

90% H308  
C308  
GRAY + 10% H11  
C62  
WHITE - MARKING **A**

C364  
AIRCRAFT  
GRAY-GREEN - MARKINGS **B, C, D, E, F**

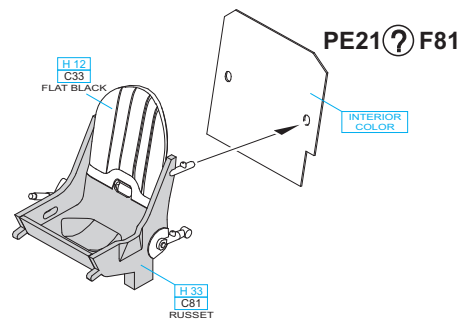
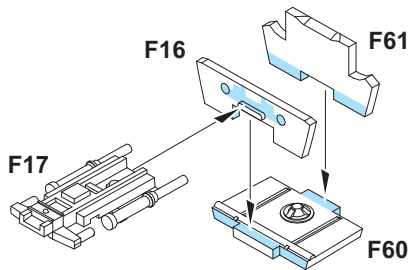
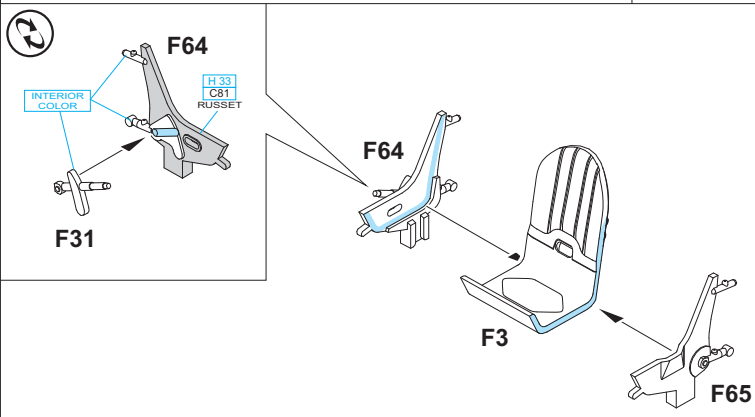
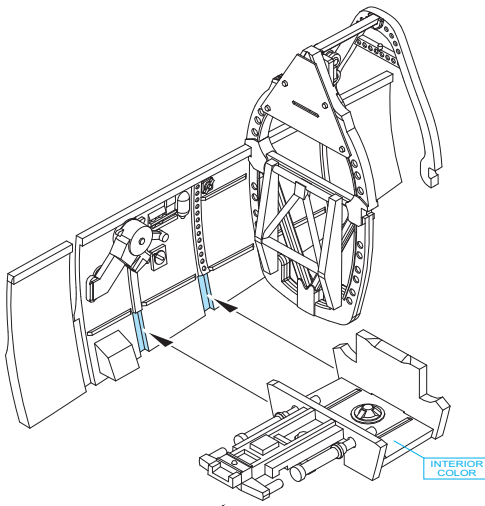
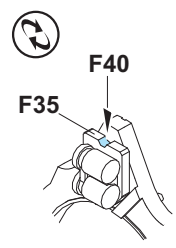
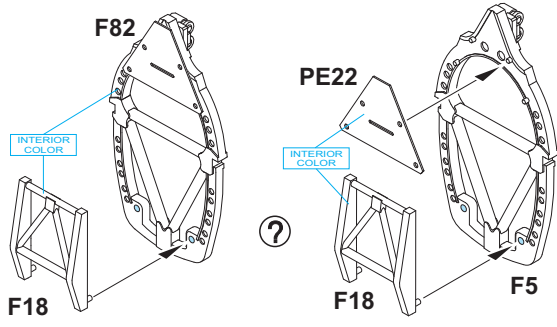
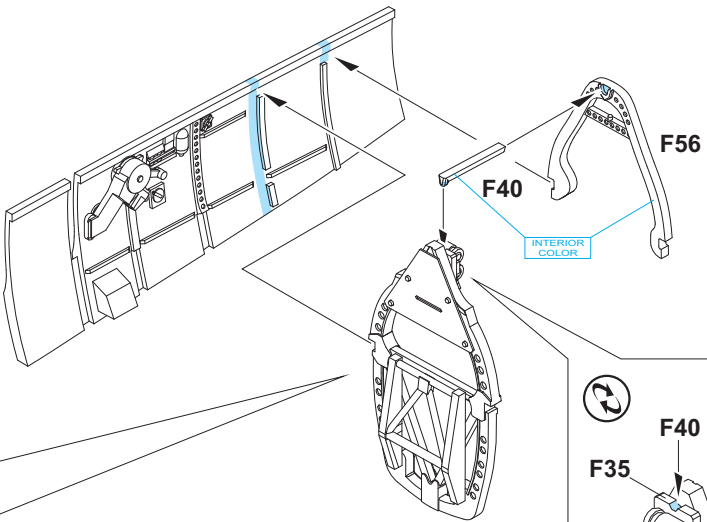
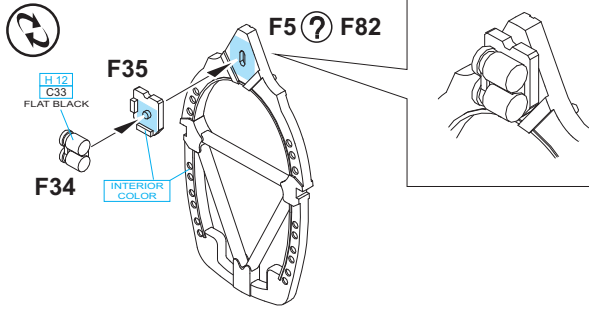
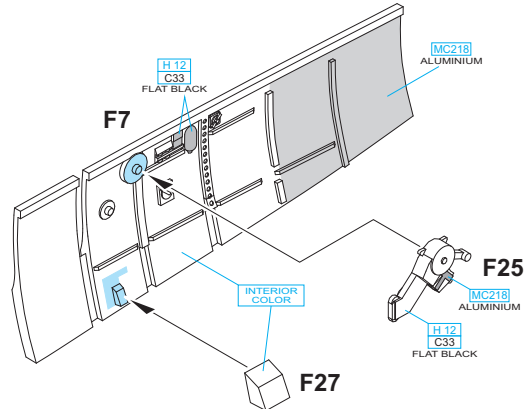
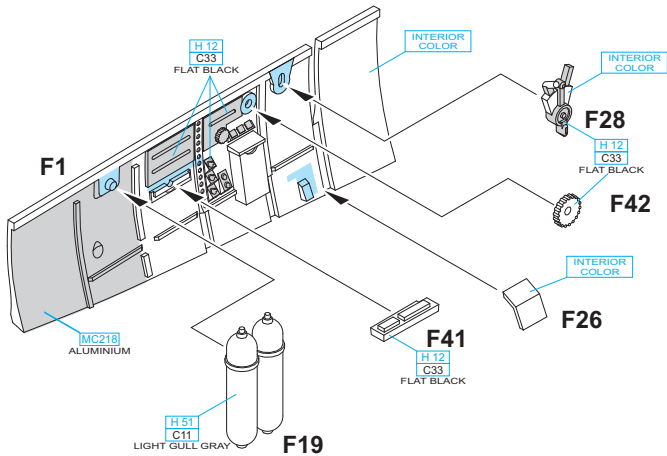

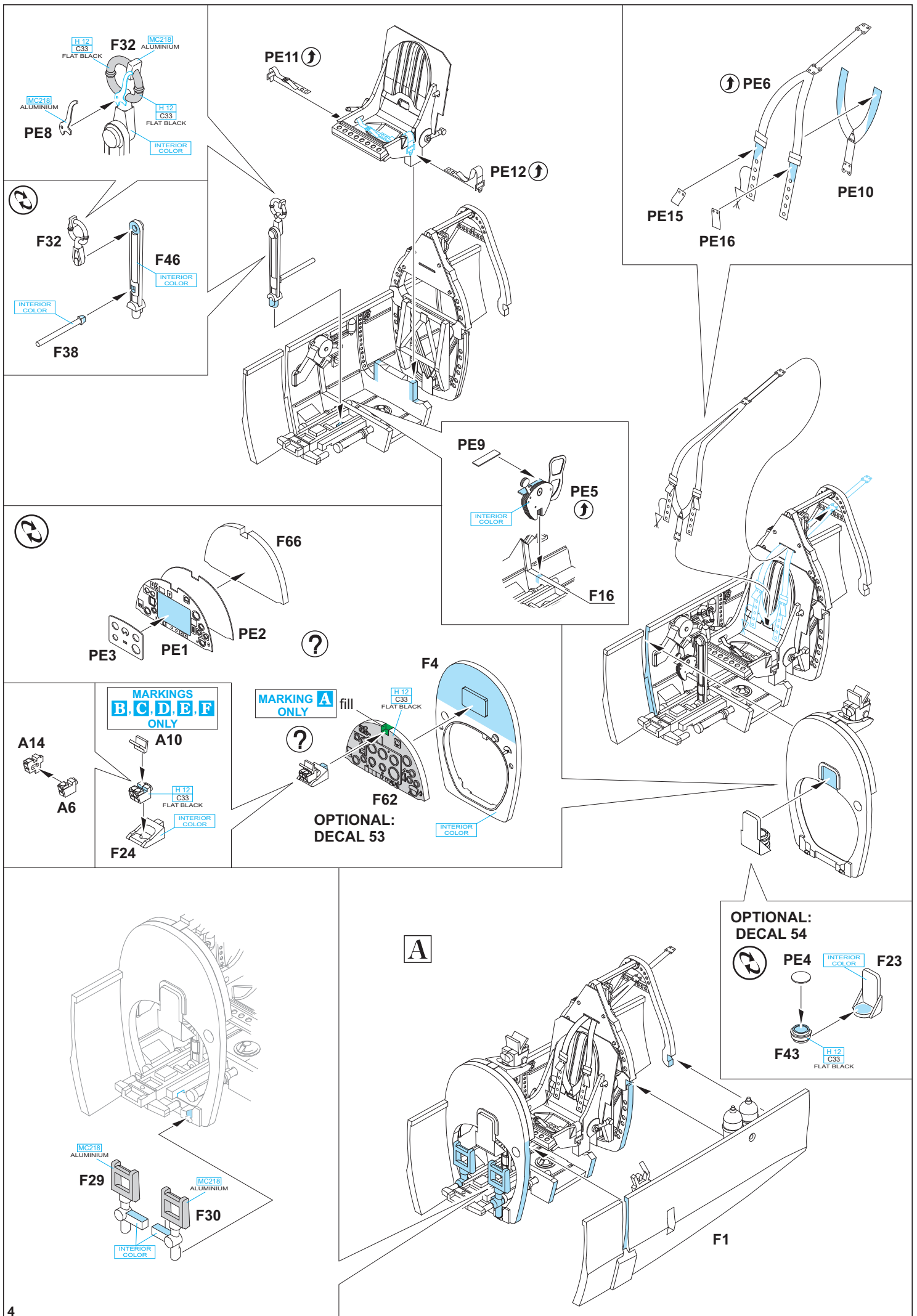

FOR CLOSED CANOPY ONLY

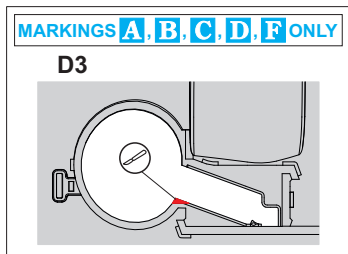
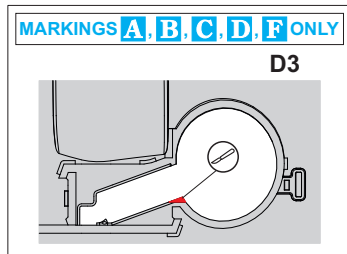
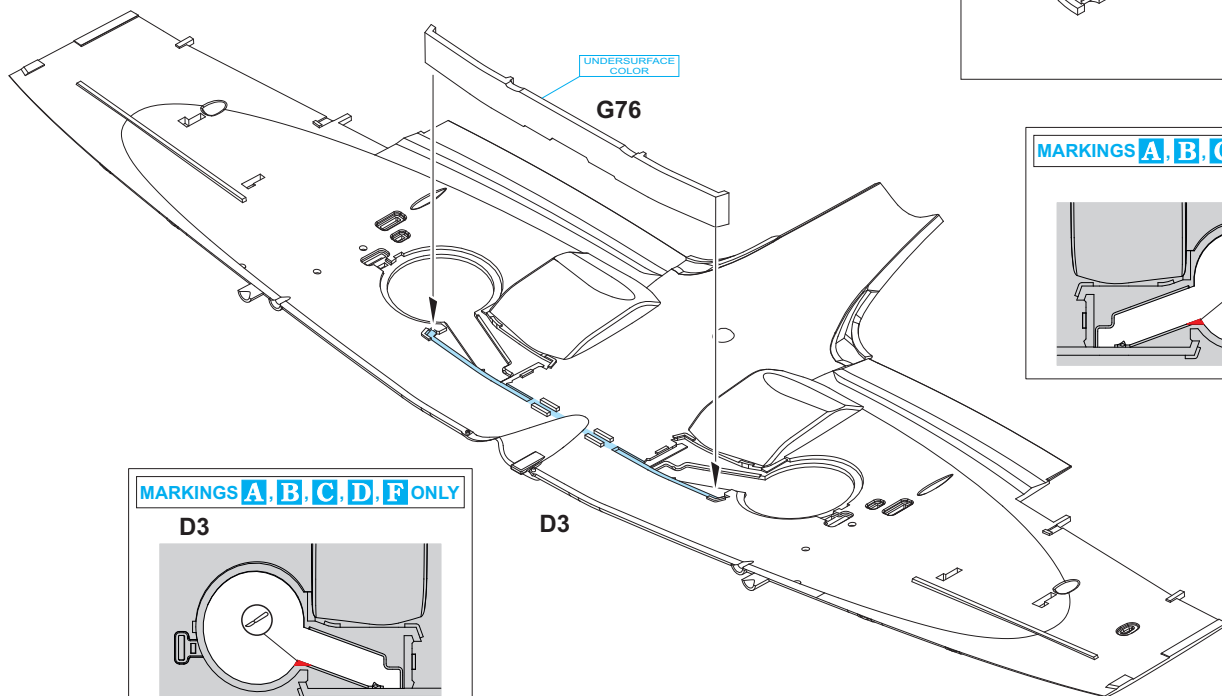
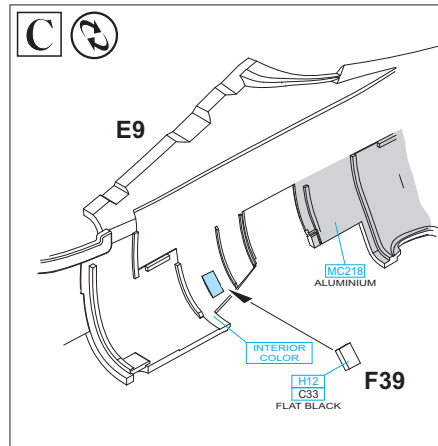
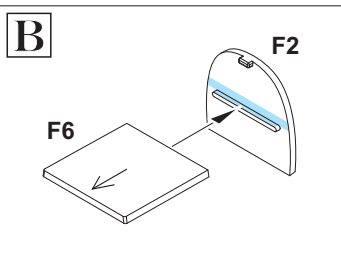
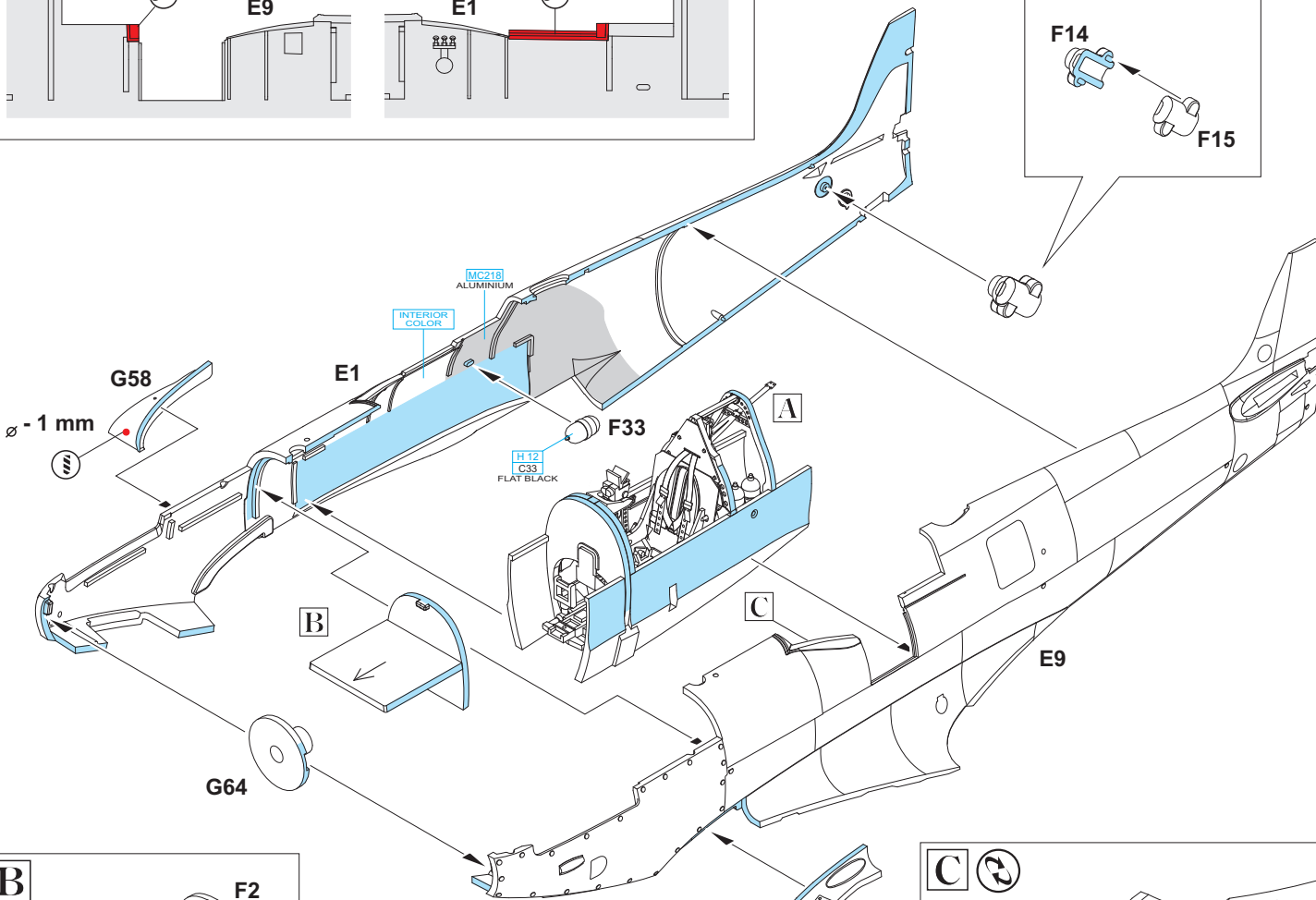
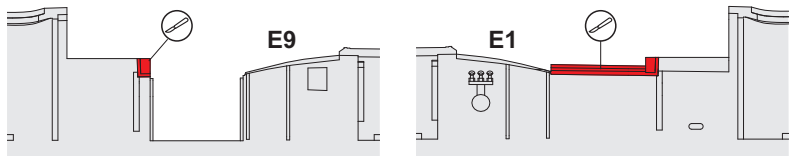

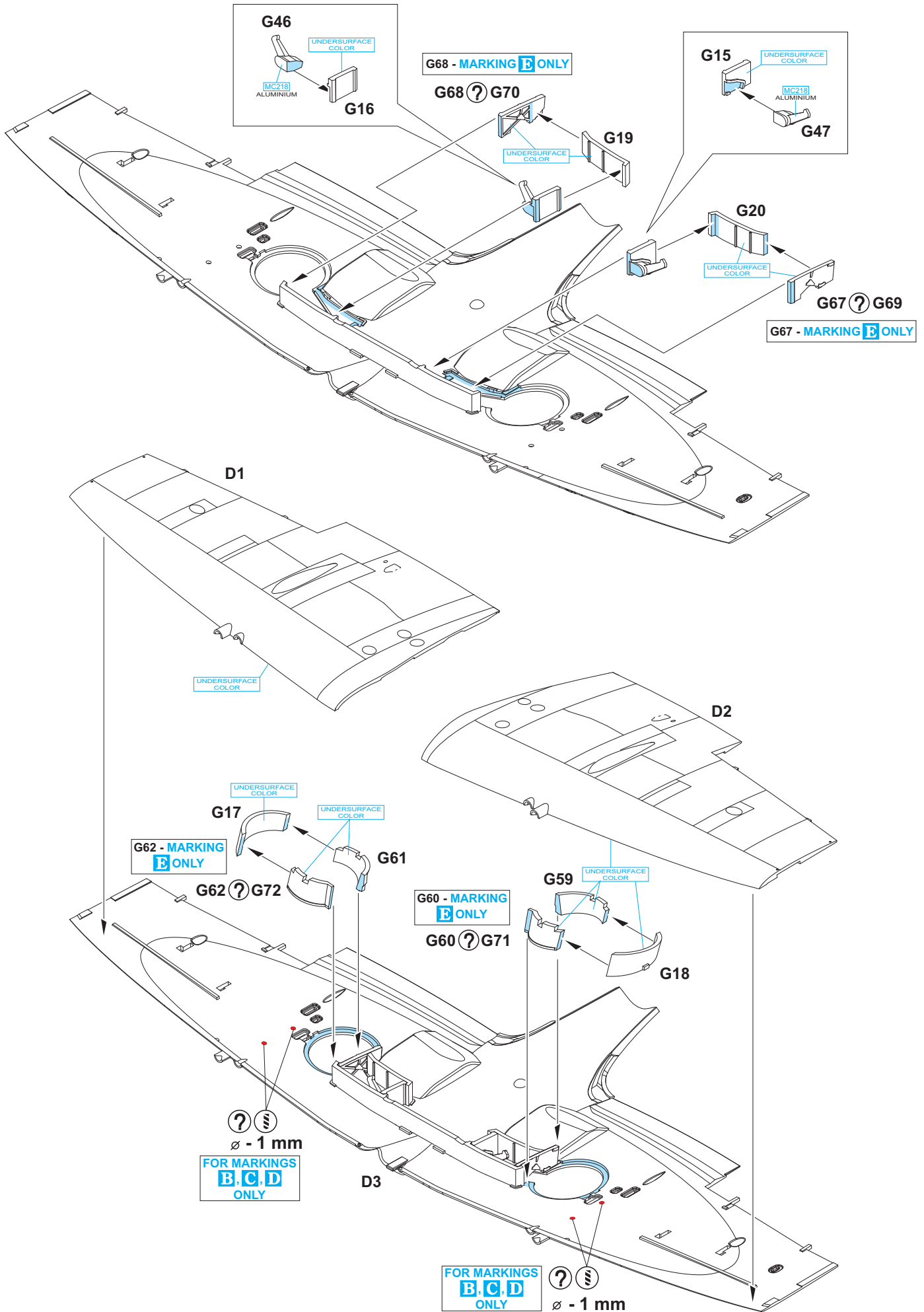

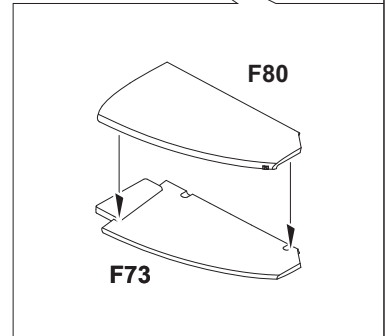
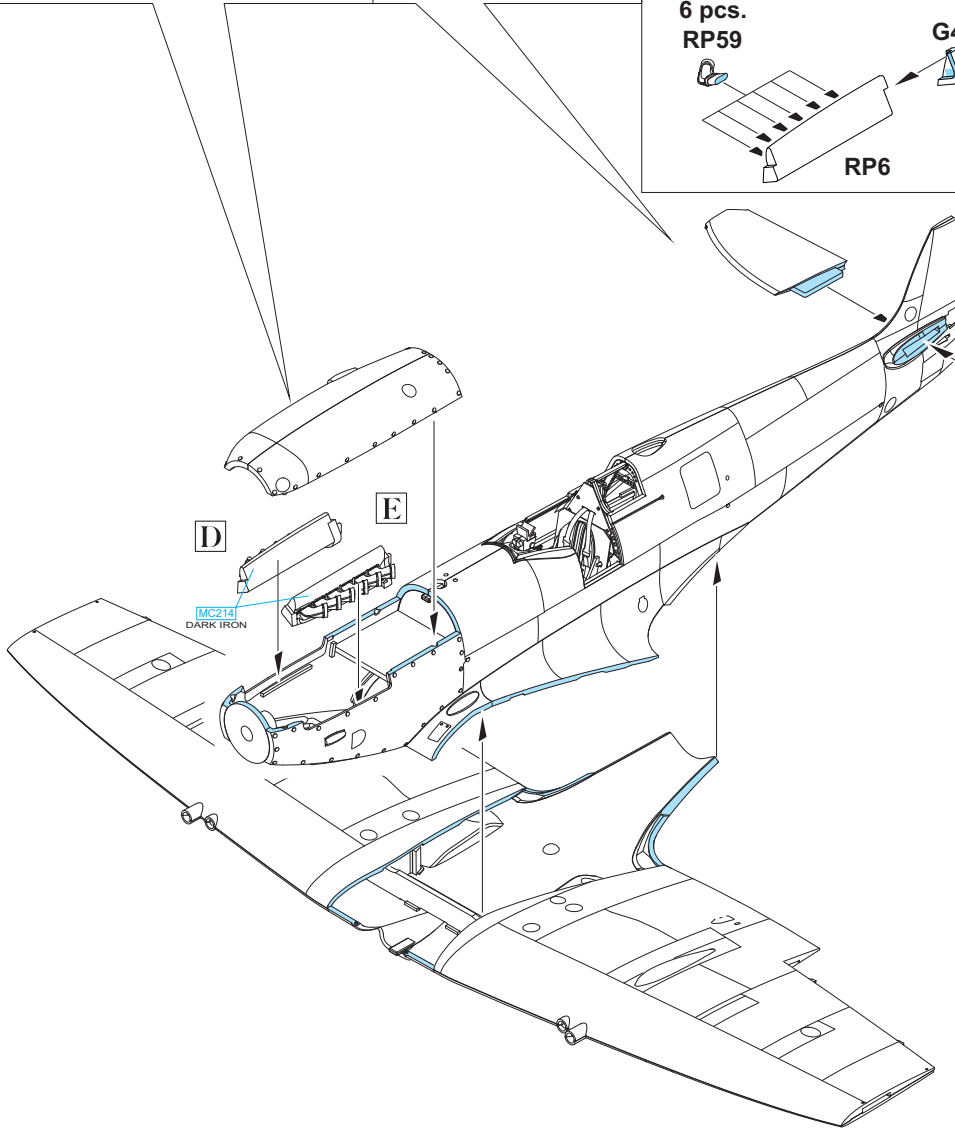
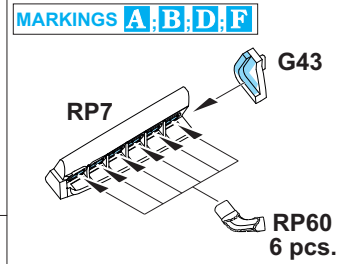
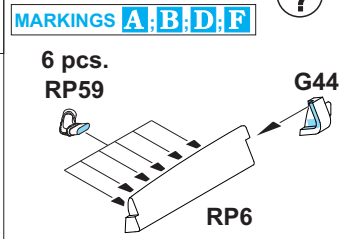
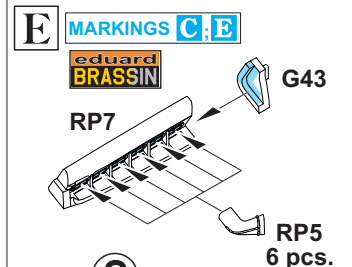
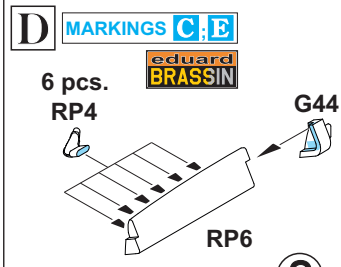
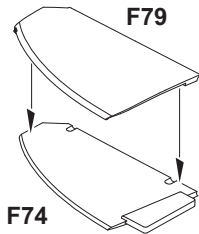
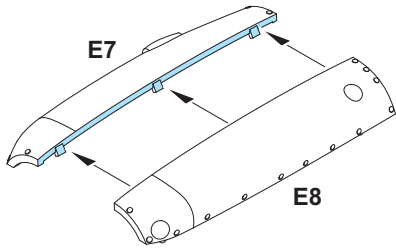

**F8 - MARKING E** F8  
**GLUE PARTS F52 & F53 ONE BY ONE**

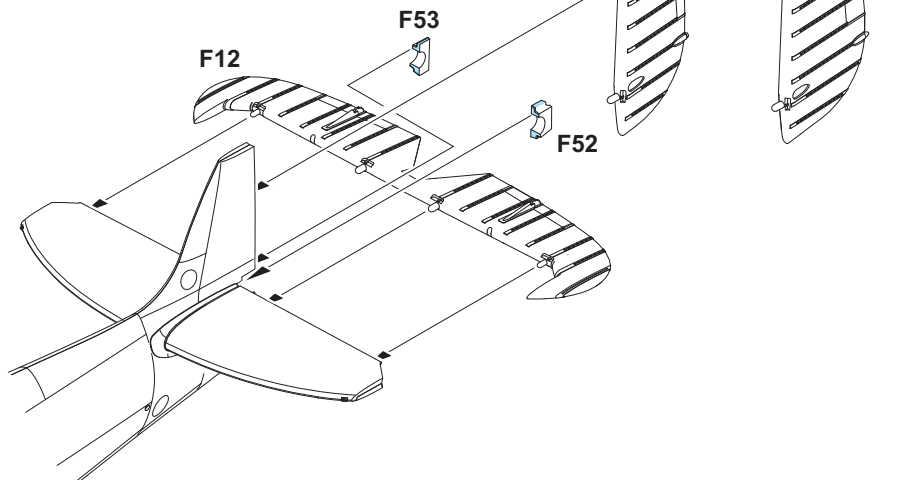

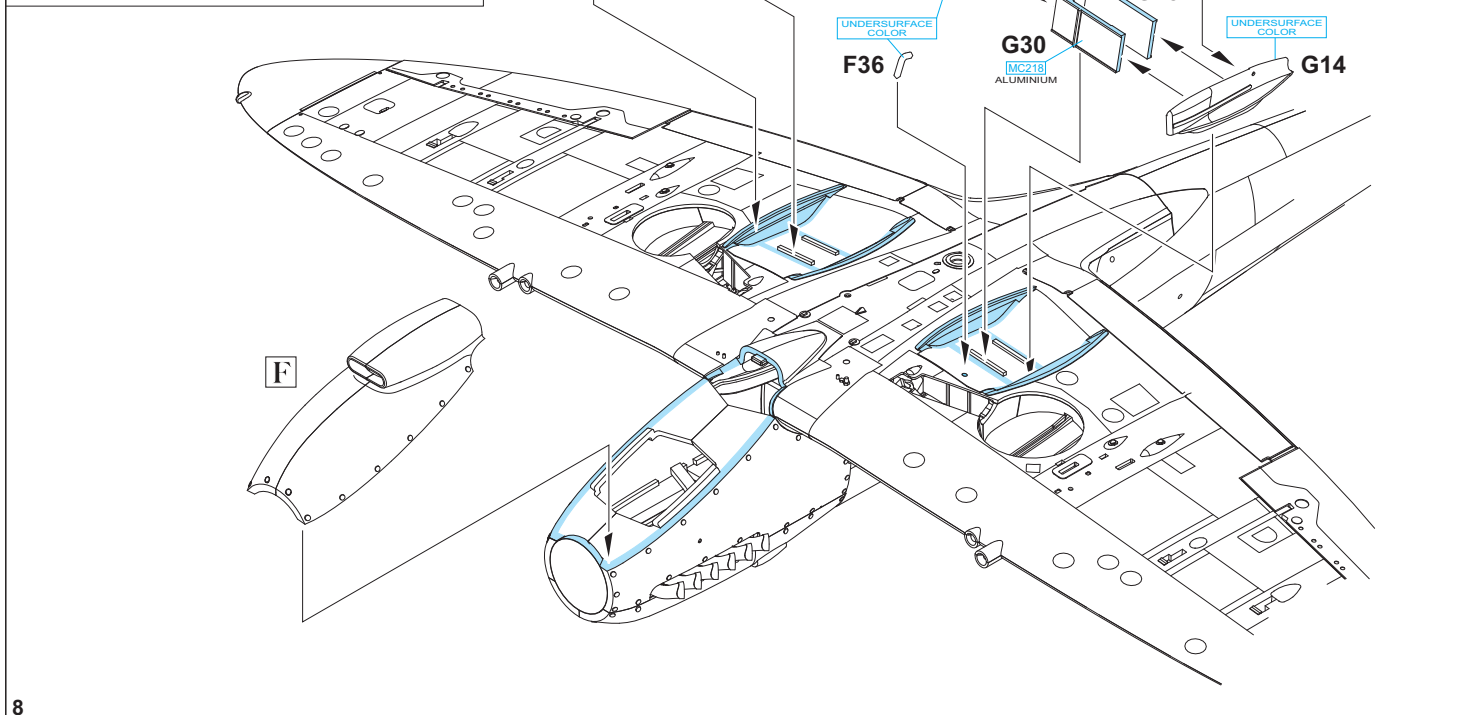
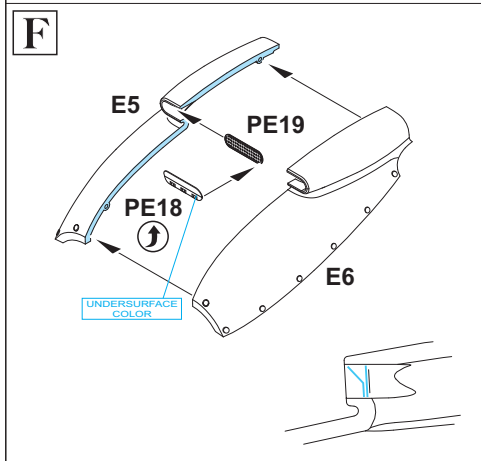
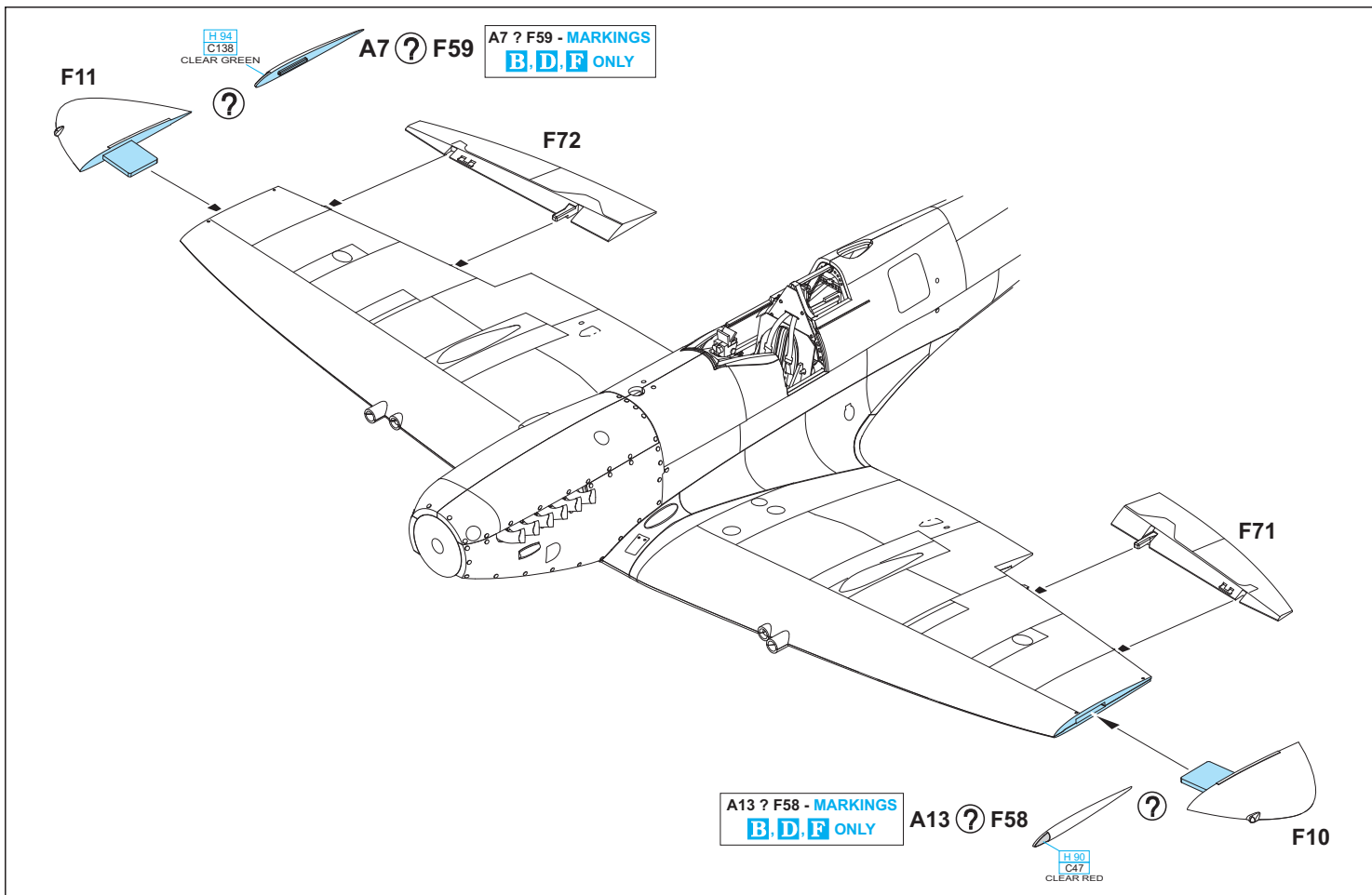



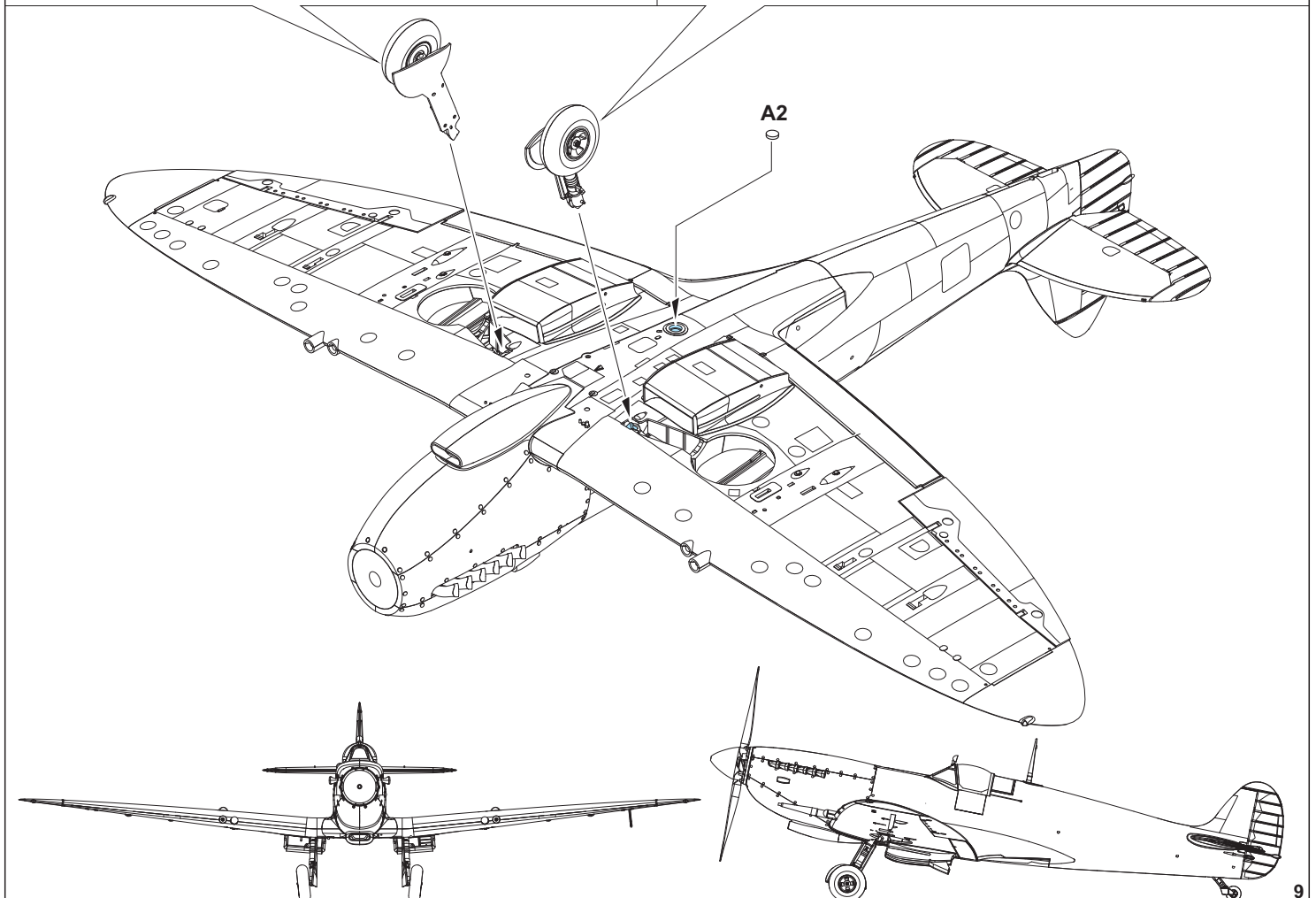
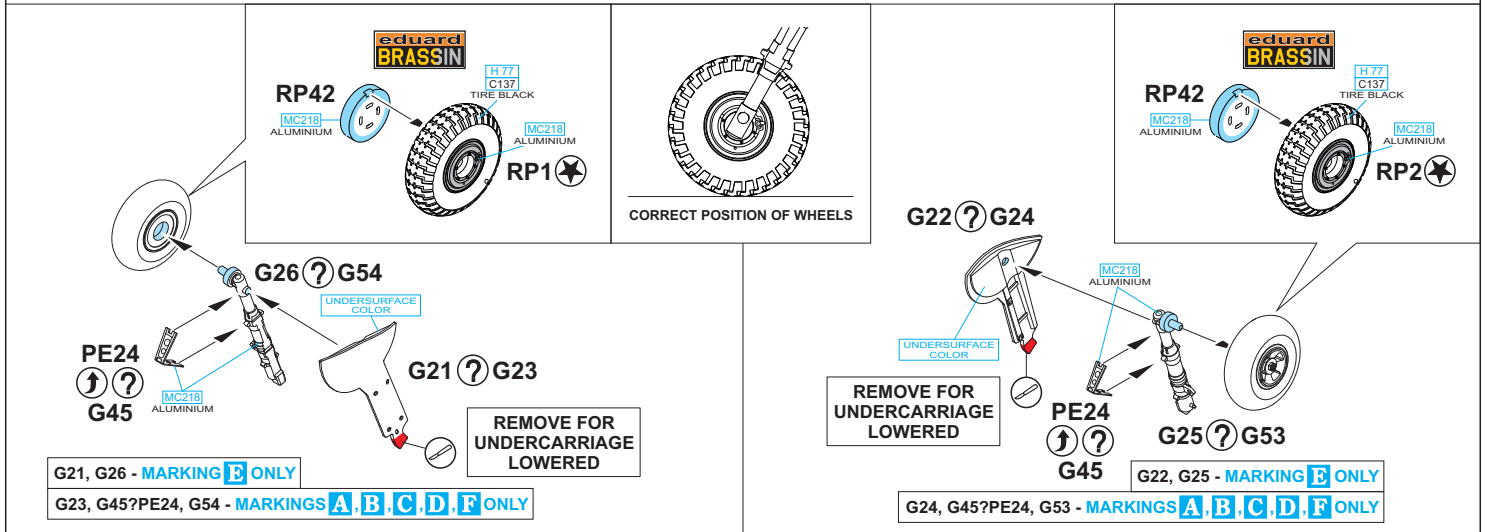
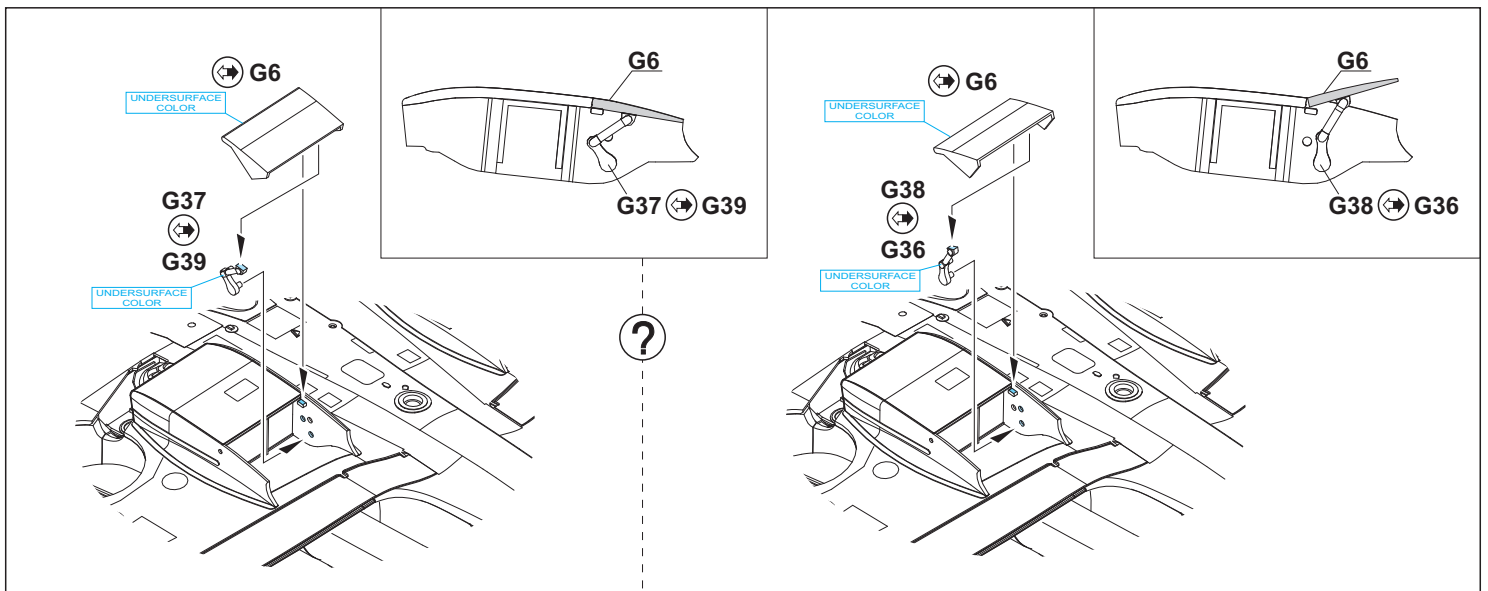

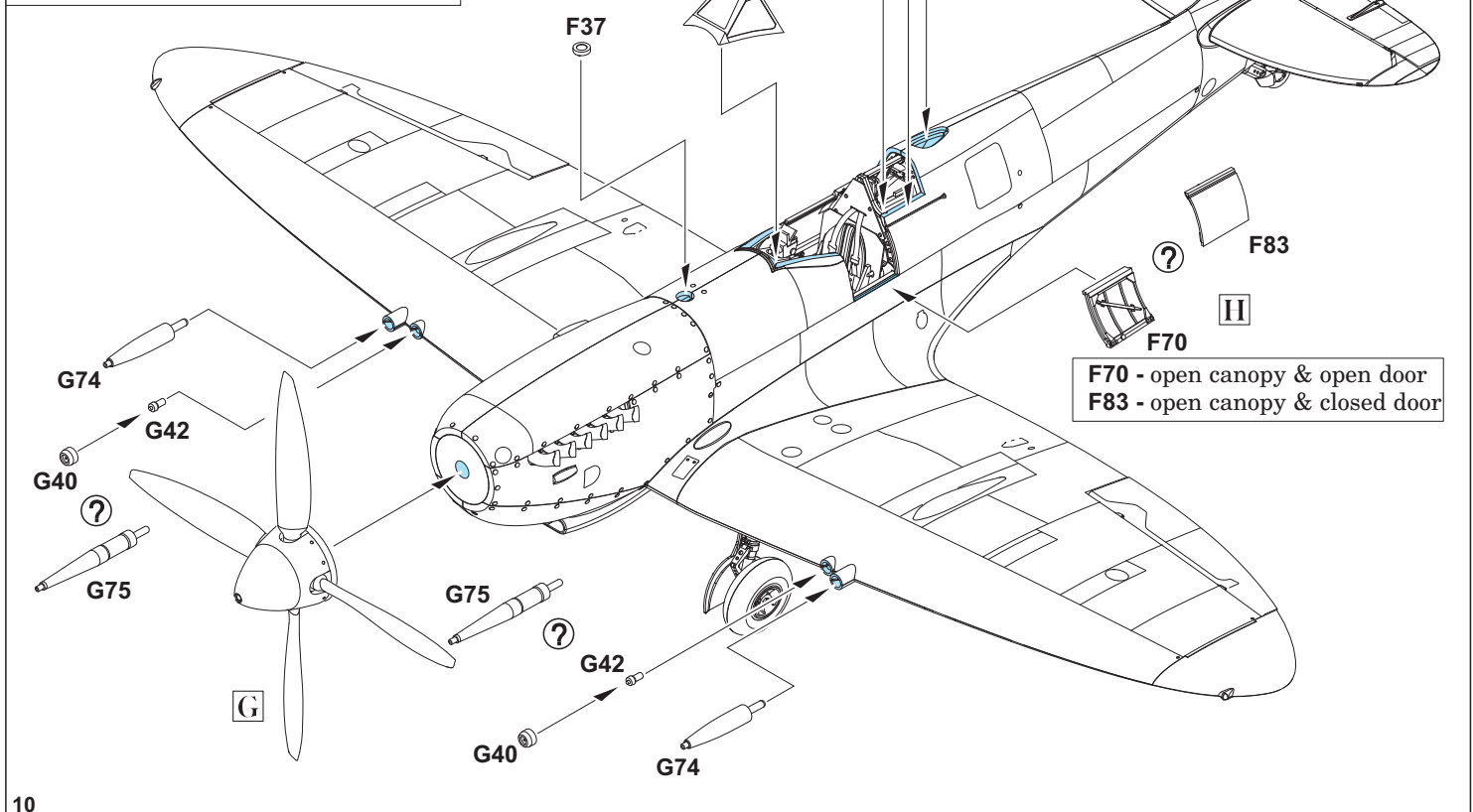
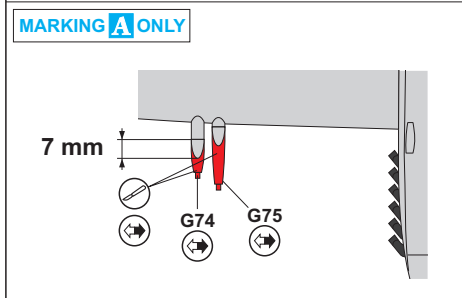
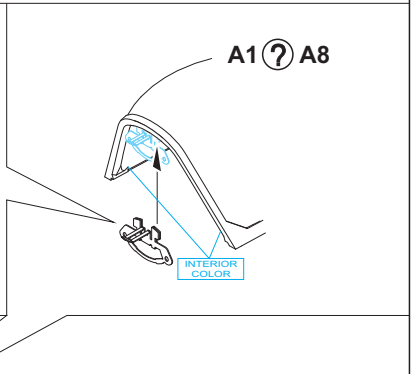
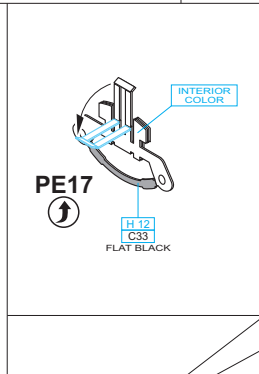
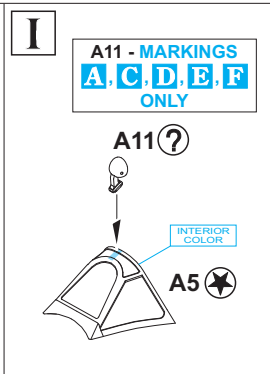
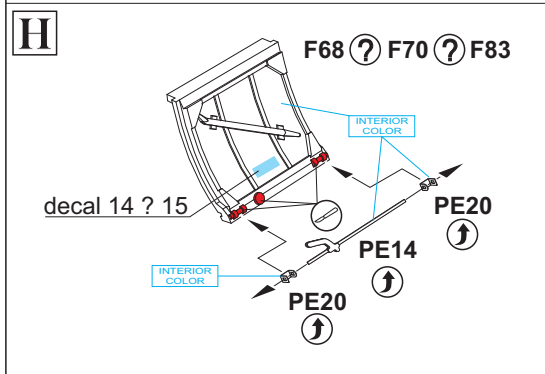
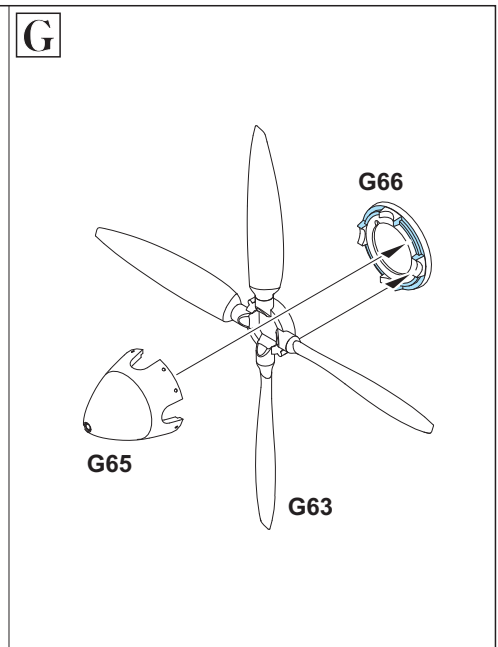
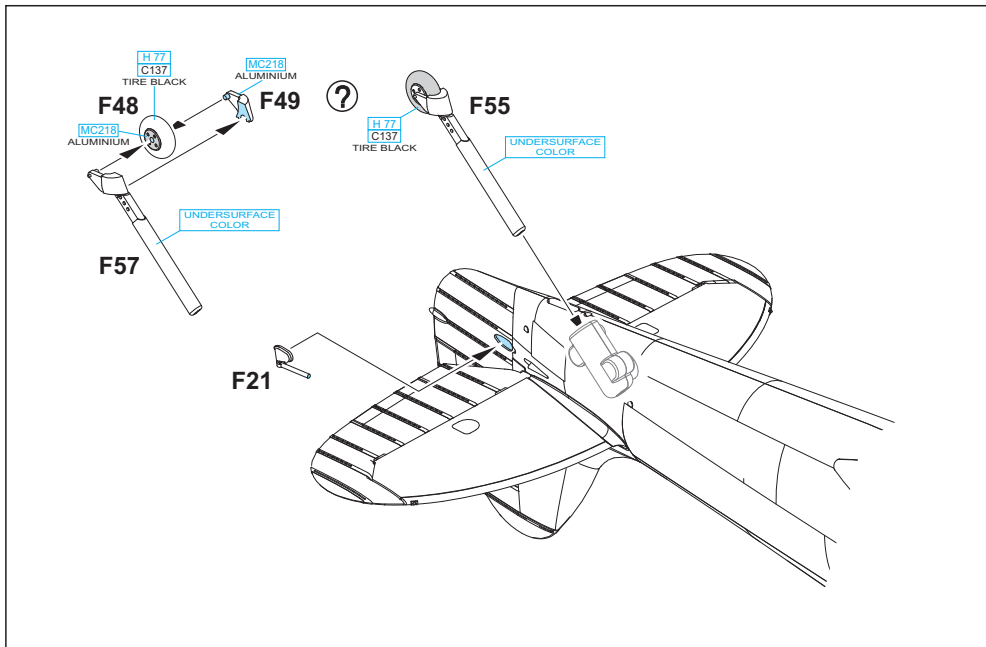

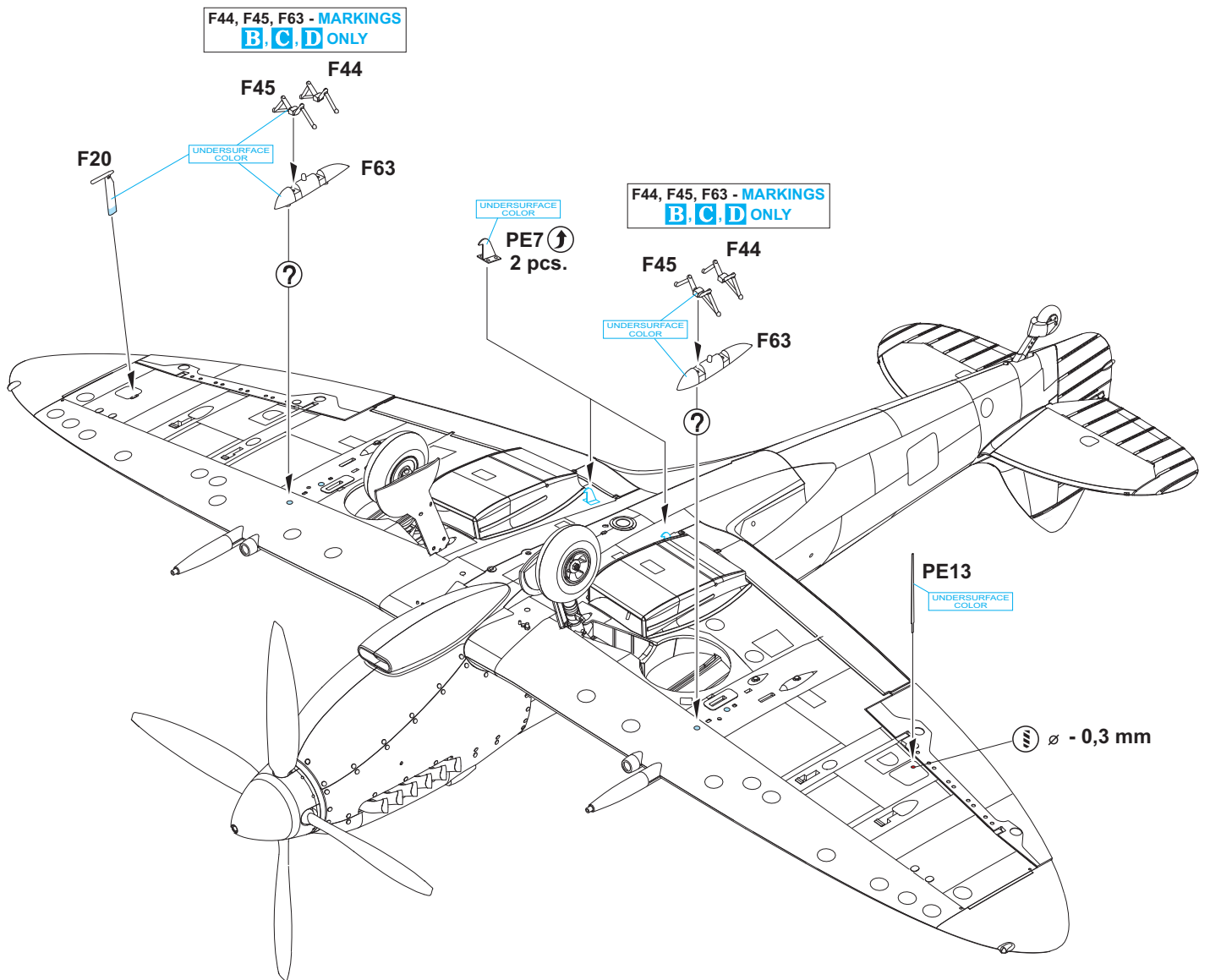
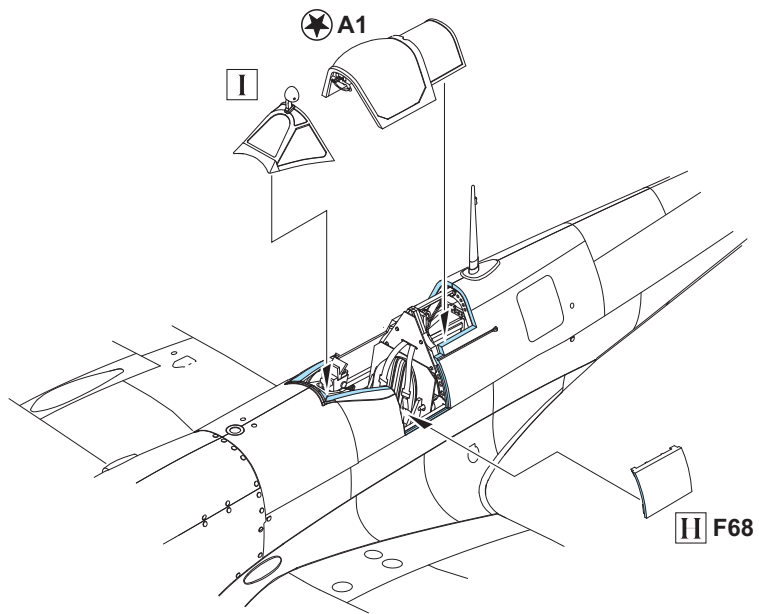

11111

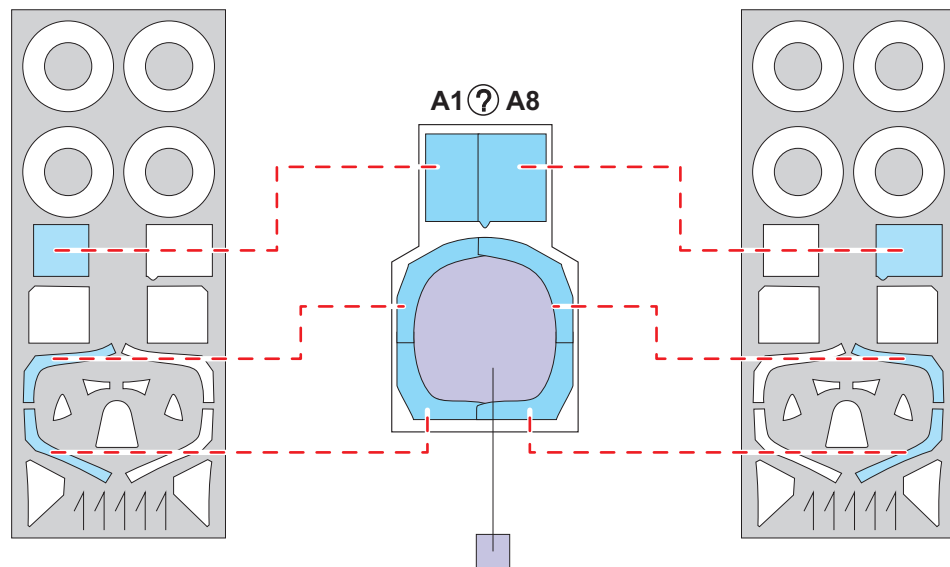

LIQUID MASK

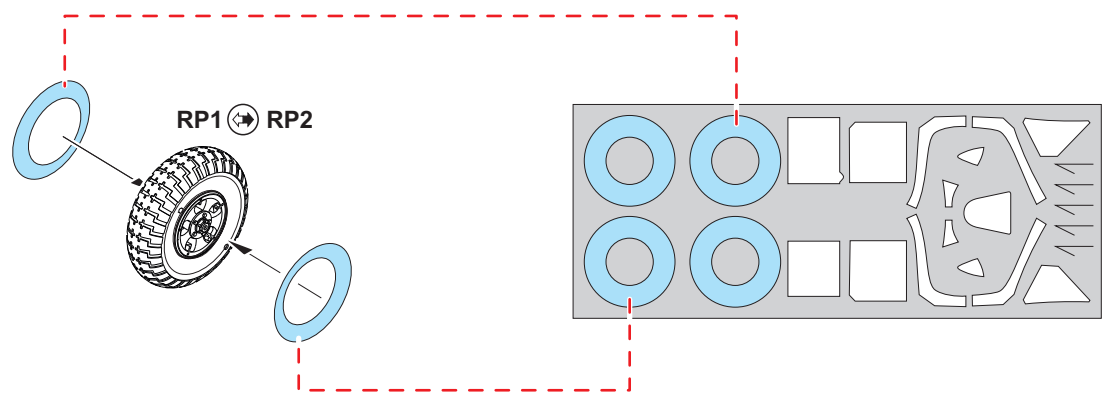
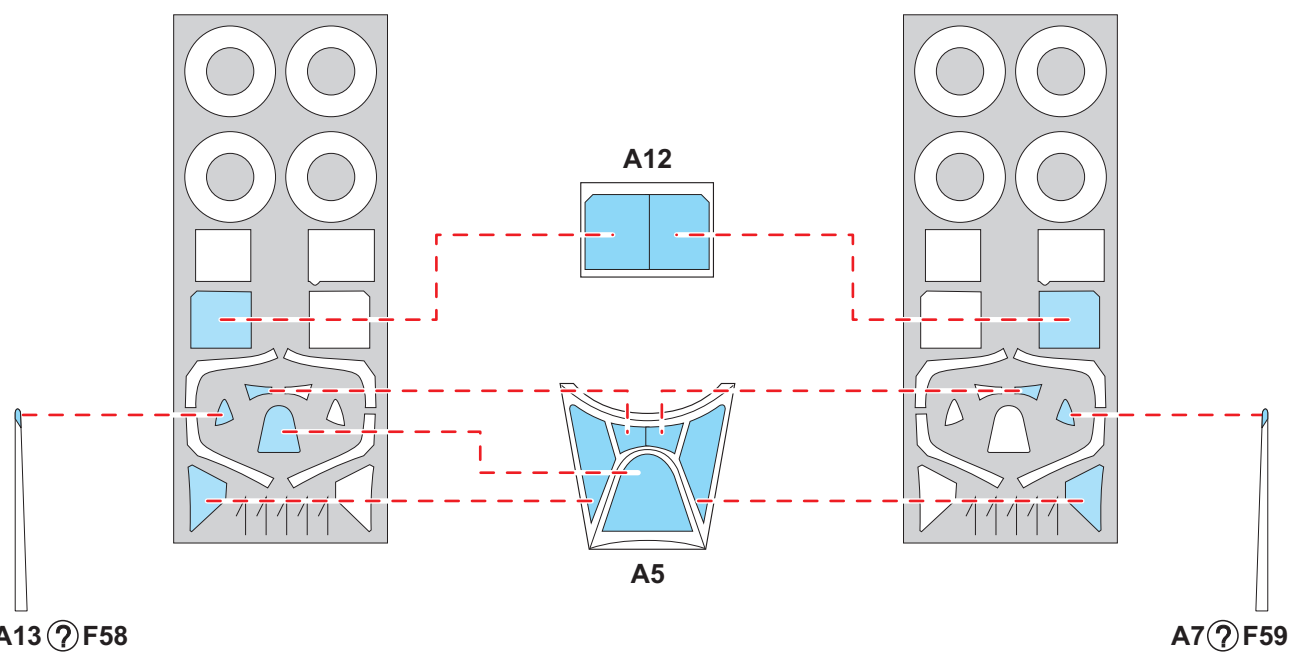

# A LF Mk.IXe, 2057 (ex-TE554), 105th Tajeset, Ramat David Air Base, Israel, 1955

The best known Israeli Spitfire is TE554, which was put into service with the 105th Tajeset in 1952 with the serial 2057/57. The aircraft crashed in 1954, after which it was sold to Burma. During repairs, then the commander of Ramat David Base, Ezer Weizman, determined that the aircraft should be preserved as his own personal plane. The aircraft was stripped of its armament and was given a black paint scheme with red trim. It was returned to service on June 13th, 1955 and today resides in the collection of the museum at Haterim in airworthy condition.

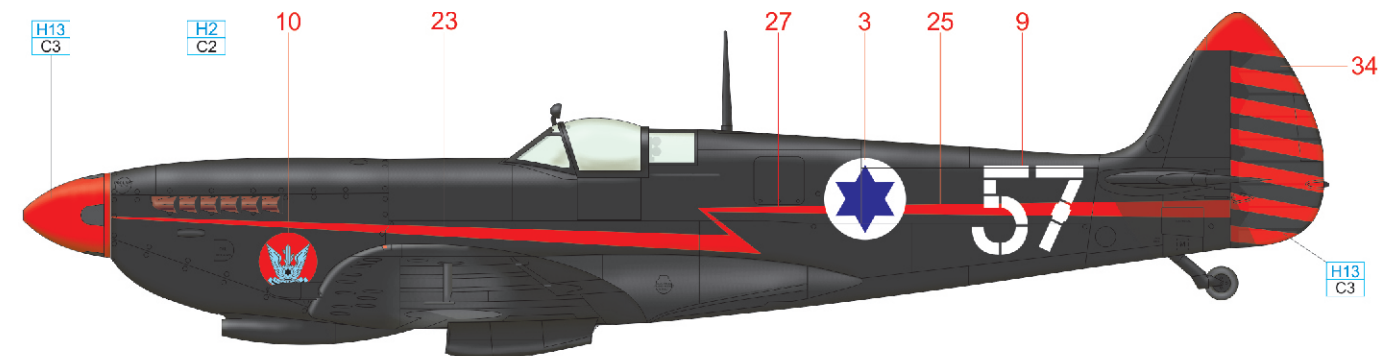

ČESKOU VERZI TEXTU NALEZNETE NA  
[www.eduard.com/s/11111](http://www.eduard.com/s/11111)

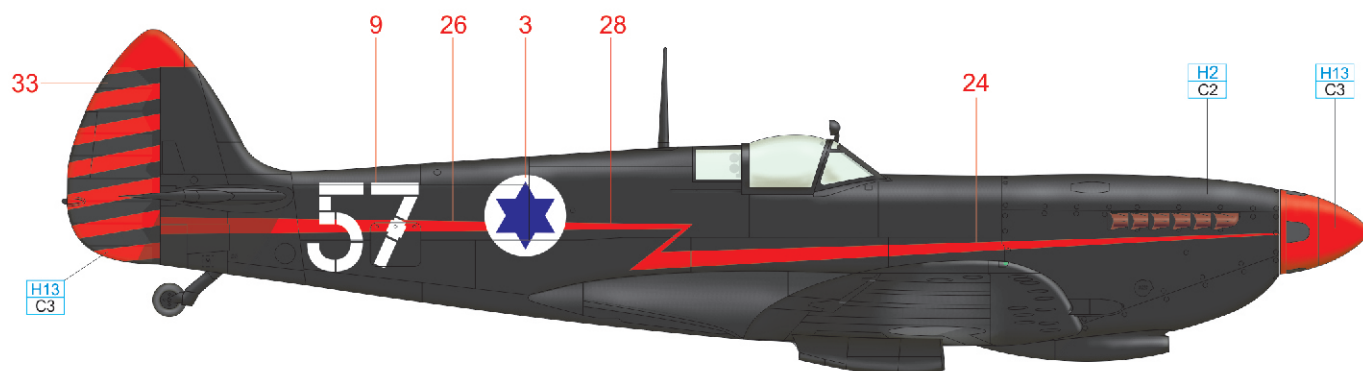
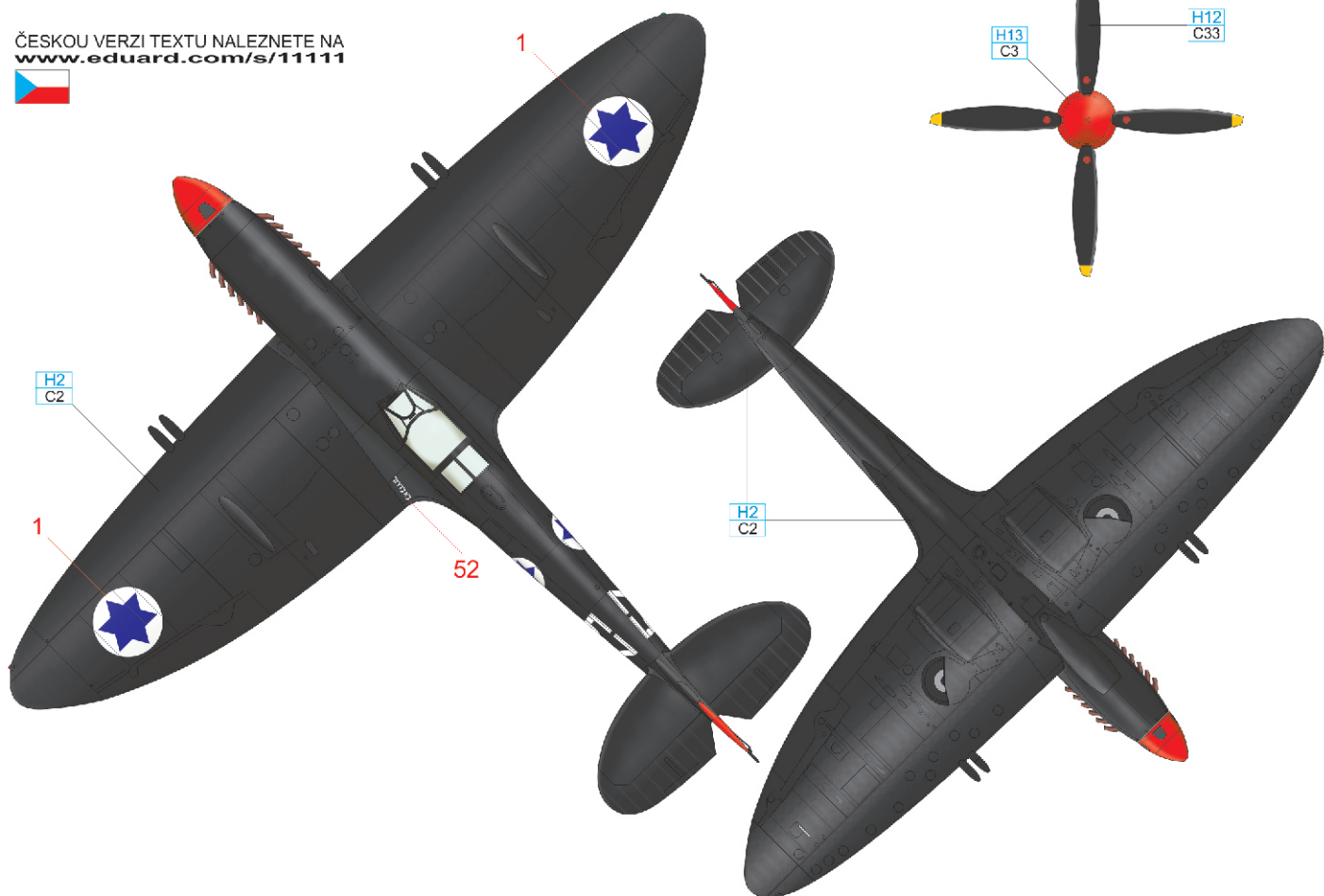

YELLOW H4 C4 RED H13 C3 BLACK H12 C33 BLACK H2 C2

eduard

# B LF Mk.IXe, 2010 (ex SL628), 101st Tajaset, Hatzor Air Base, February 1949

This Spitfire reached Israel at the end of December 1948 during Operation Velveta II, the second wave of aircraft bought from Czechoslovakia. In Israel, it was coded 2010 and carried the call sign 25. It retained the original British camouflage scheme and acquired the 101st Tajaset unit marking which included the red spinner and red and white rudder. It was one of thirty Israeli Spitfires to be delivered to Burma where it carried the serial UB433.

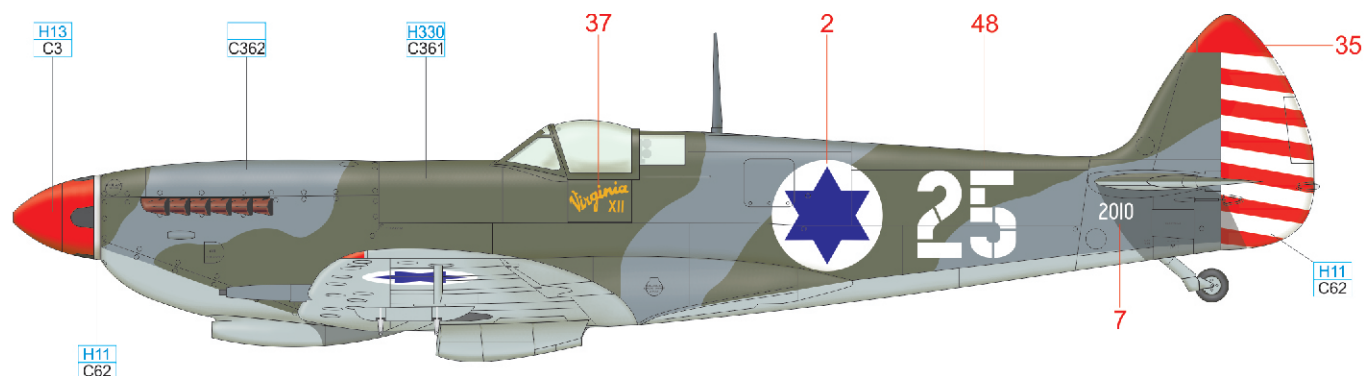

ČESKOU VERZI TEXTU NALEZNETE NA  
[www.eduard.com/s/11111](http://www.eduard.com/s/11111)

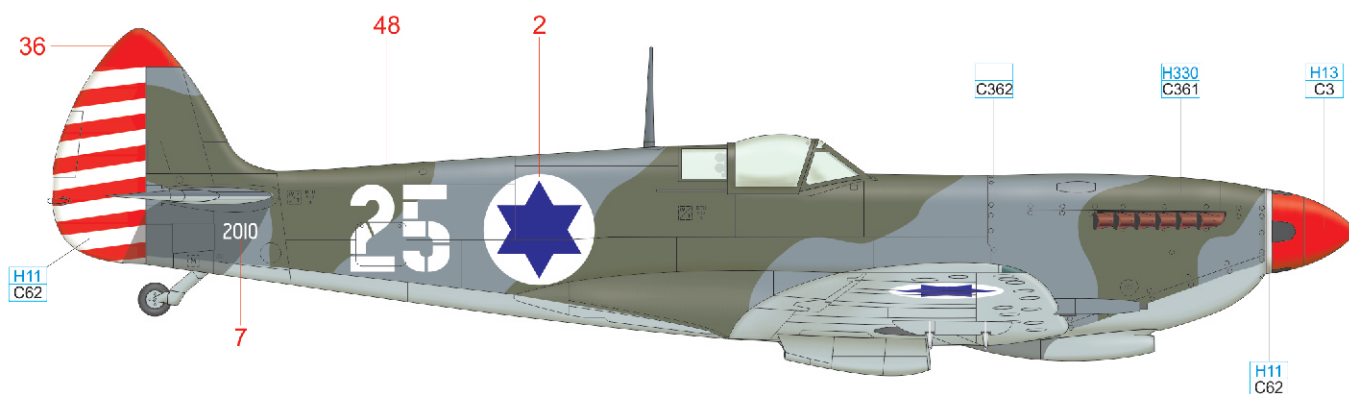
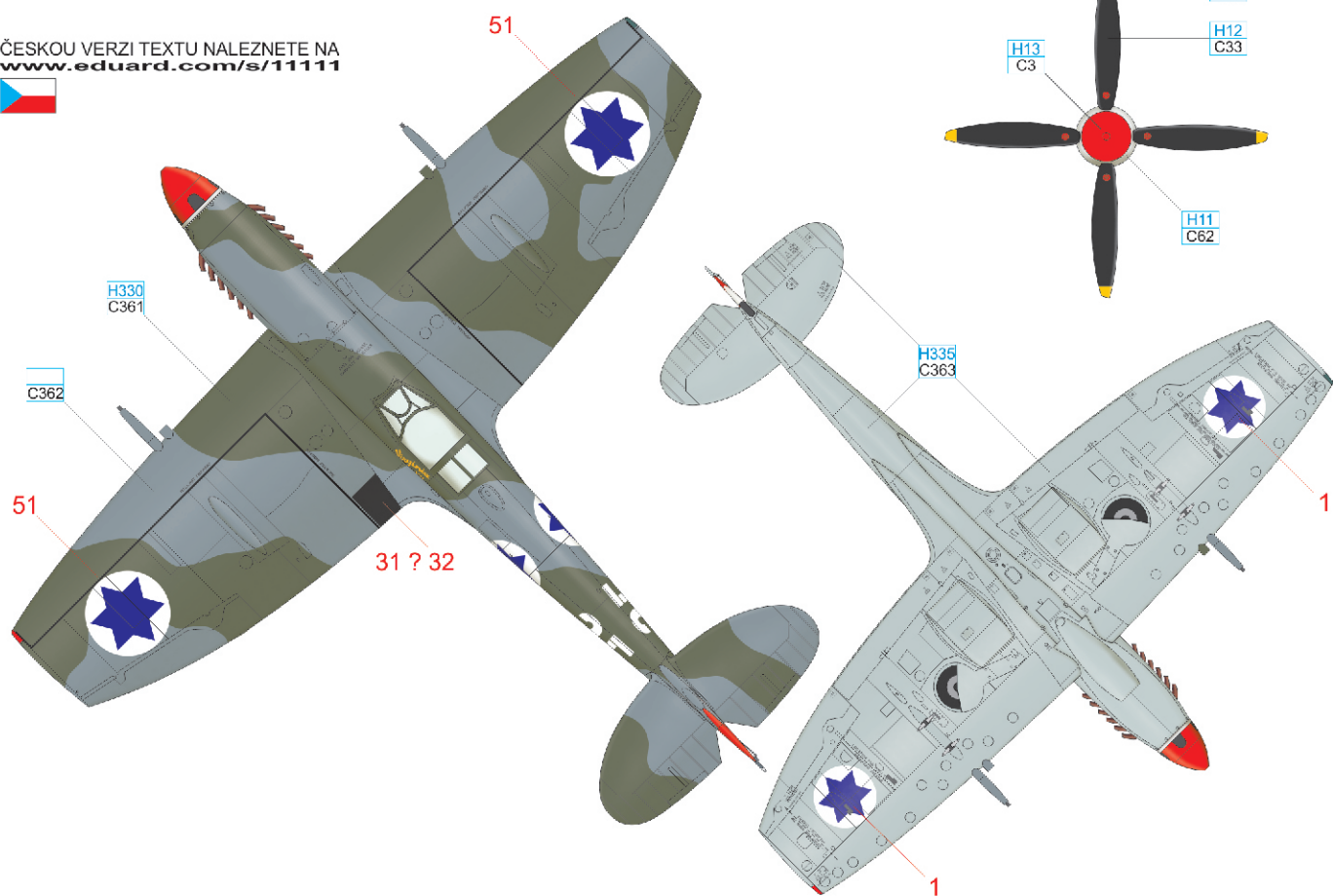

YELLOW	H4 C4	RED	H13 C3
WHITE	H11 C62	MEDIUM SEA GRAY	H335 C363
	OCEAN GRAY	C362	DARK GREEN
	H330 C361	BLACK	H12 C33

# C LF Mk.IXe, 2058 (ex TE515), 105th Tajeset, Ramat David Air Base, Israel, 1953

An exception among the aircraft that were delivered from Czechoslovakia was TE515, which sported a silver finish with a striking red, or blue, lightning flash on both sides of the fuselage. In Czechoslovakia, the aircraft served with the 2nd Fighter Air Division and served as a demonstration bird at air shows. On such occasions, the aircraft was piloted by the excellent fighter pilot and acrobat Karel Posta, DFC. The appearance was preserved in Israel, where it gained the serial 2058. In memory of pilot Joel Kosta, his name was carried in Hebrew on the starboard side of the cowl.

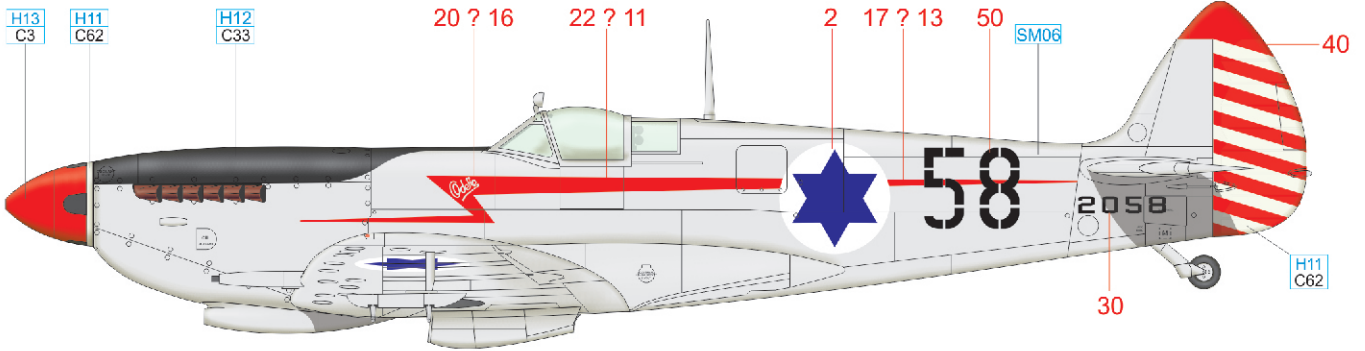

ČESKOU VERZI TEXTU NALEZNETE NA  
[www.eduard.com/s/11111](http://www.eduard.com/s/11111)

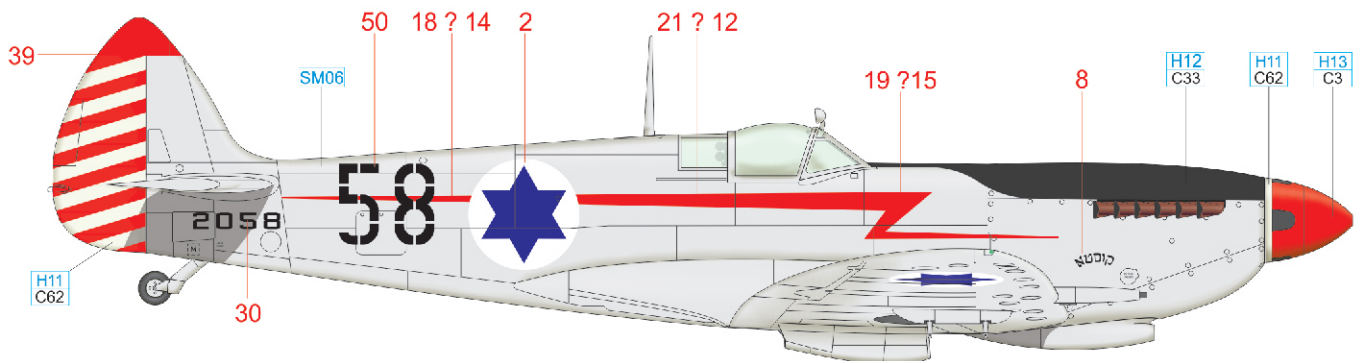
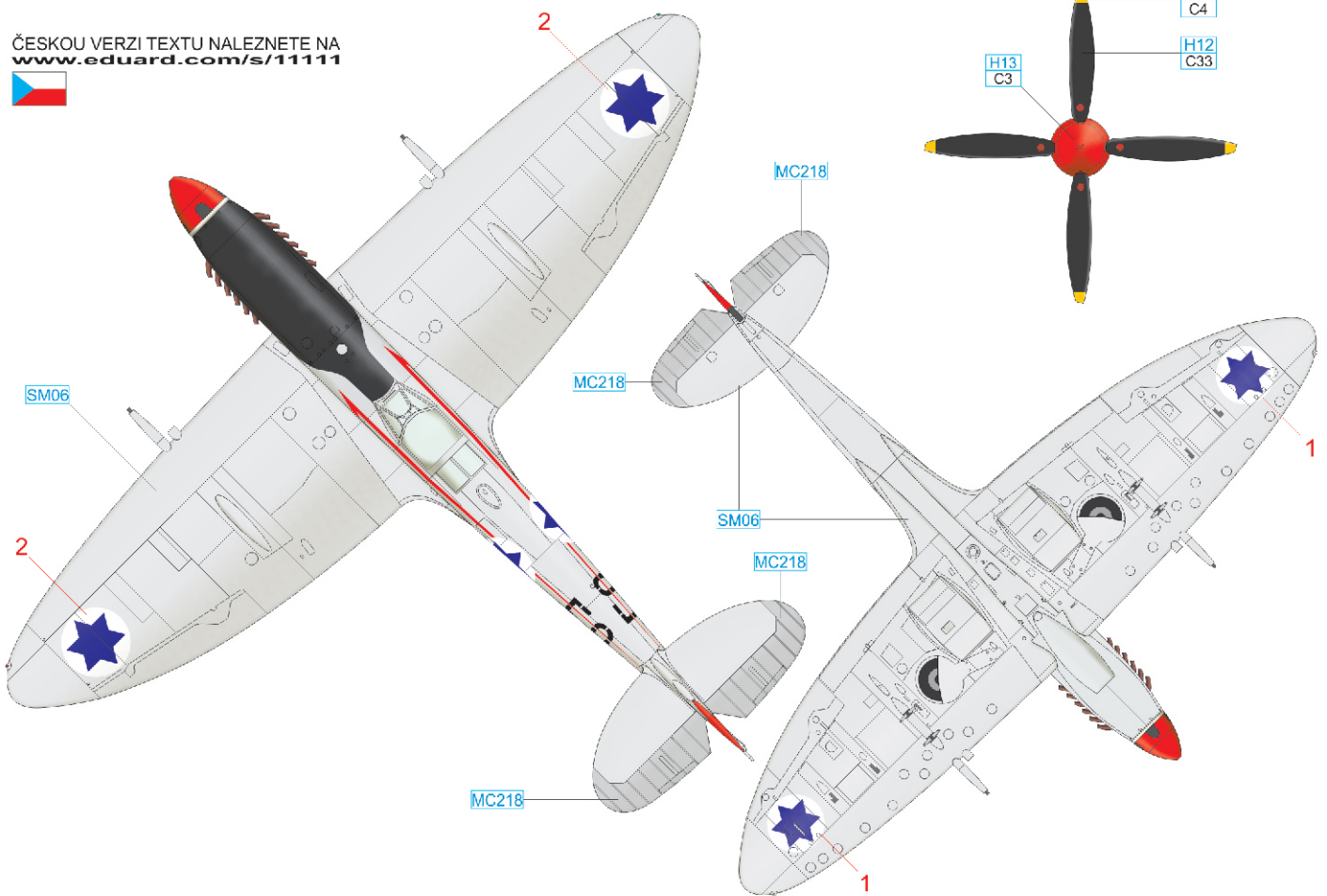

YELLOW	H4 C4	BLACK	H12 C33	CHROME SILVER	SM06
WHITE	H11 C62	RED	H13 C3	ALUMINIUM	MC218

# D LF Mk.IXe, 2035 (ex TE575), 105th Tajeset, Ramat David Air Base, Israel, April 1950

Spitfire 2035/35 (TE575) was delivered from Czechoslovakia by ground in 1949 and carried a non-standard serial. It served with the 101st and 105th Tajesets while with the Cheyl Ha'Avir. In May 1951 this aircraft was damaged by Syrian anti-aircraft fire at Tel-Motila. At the time, it was already serving with the 105th Tajeset, but retained the 101st's red and white striped rudder. It was stricken off charge by the Cheyl Ha'Avir in February 1956.

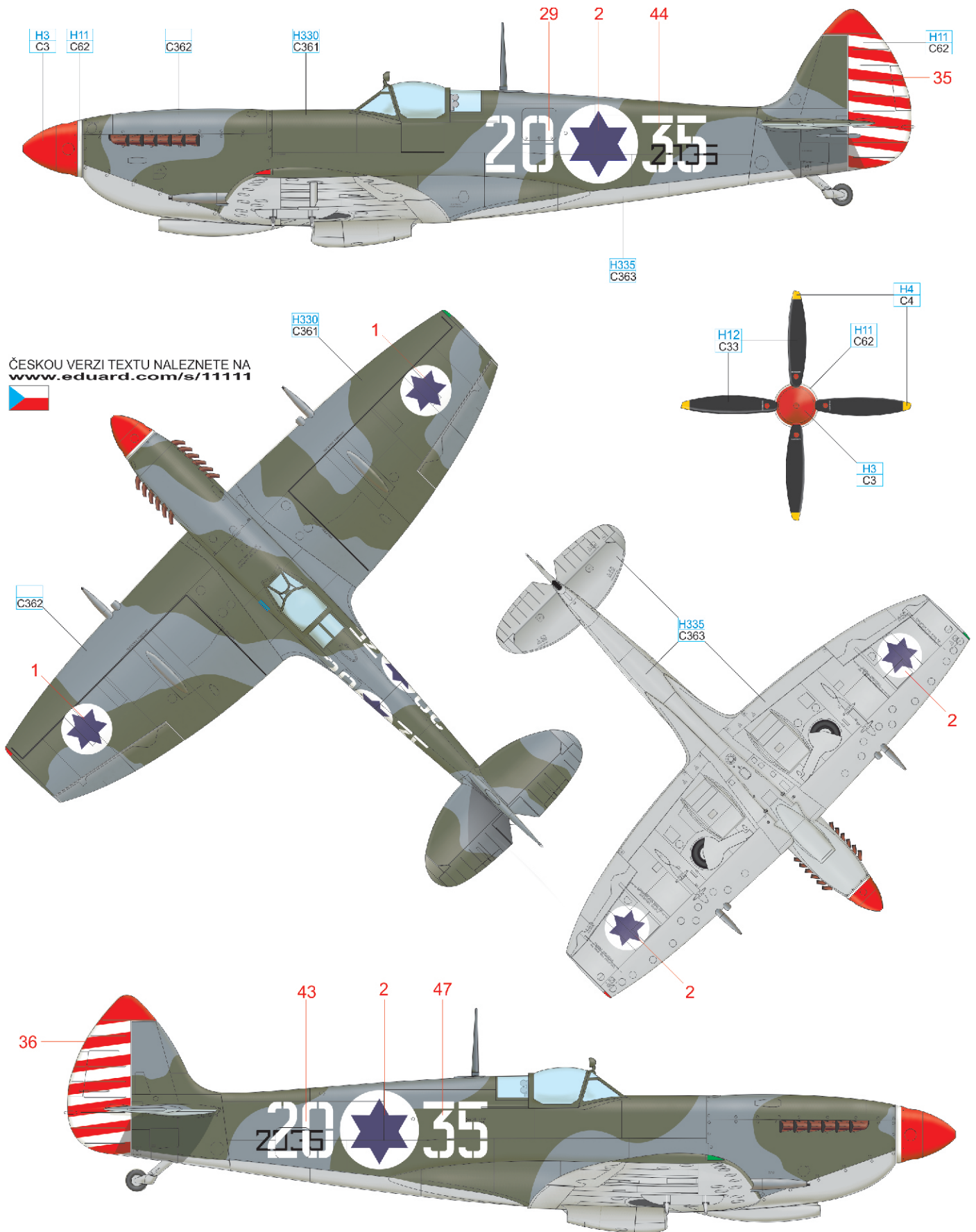

ČESKOU VERZI TEXTU NALEZNETE NA [www.eduard.com/s/11111](http://www.eduard.com/s/11111)



YELLOW	H4 C4	RED	H3 C3
WHITE	H11 C62	MEDIUM SEA GRAY	H335 C363
	OCEAN GRAY	C362	DARK GREEN
	H330 C361	BLACK	H12 C33



# E LF Mk.IXe, 2079, 107th Tajaset, Ramat David Air Base, Israel, 1954

Besides Czechoslovakia, Israel secured some Spitfires from Italy as well. Among these was a Spitfire that was serialised 2079. The original serial number is unknown. In the Israeli Air Force, it served with No. 107 Squadron and was eventually sold to Burma where it flew with the number UB448. The blue striped rudder and spinner were markings specific to the 107th Tajaset. The unit emblem was typically sprayed on the port side of the cowl and is documented in two forms, with a blue winged shield and without. Because there are no known left side photographs of 2079 available, both are being offered in this kit.

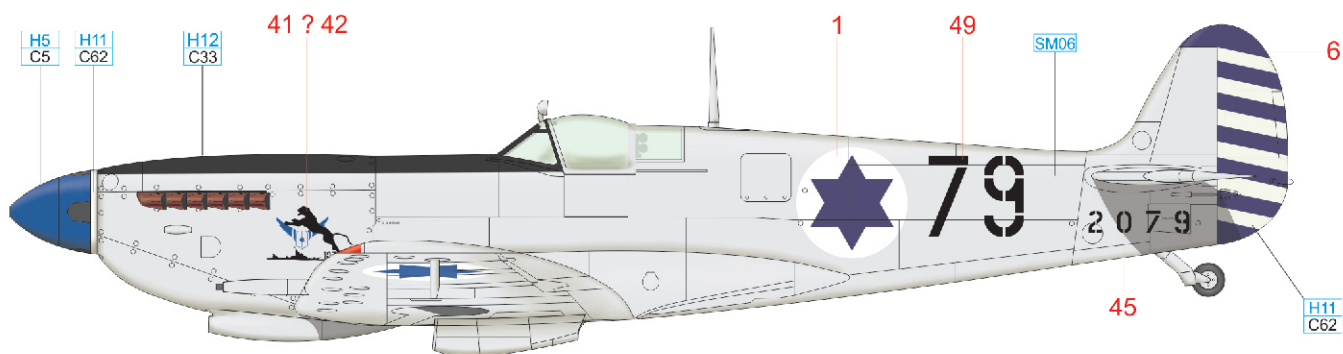

ČESKOU VERZI TEXTU NALEZNETE NA  
[www.eduard.com/s/11111](http://www.eduard.com/s/11111)

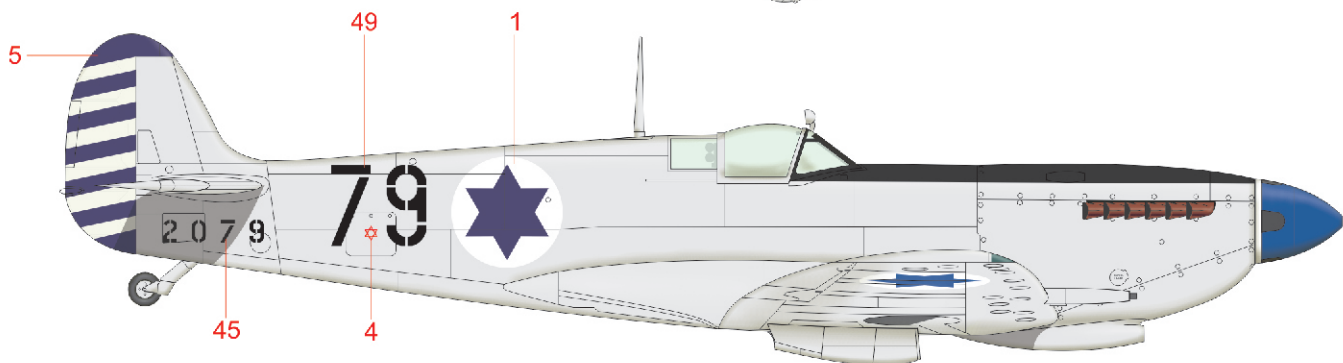
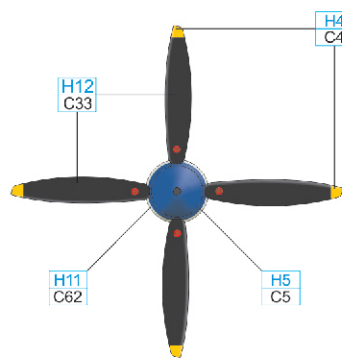
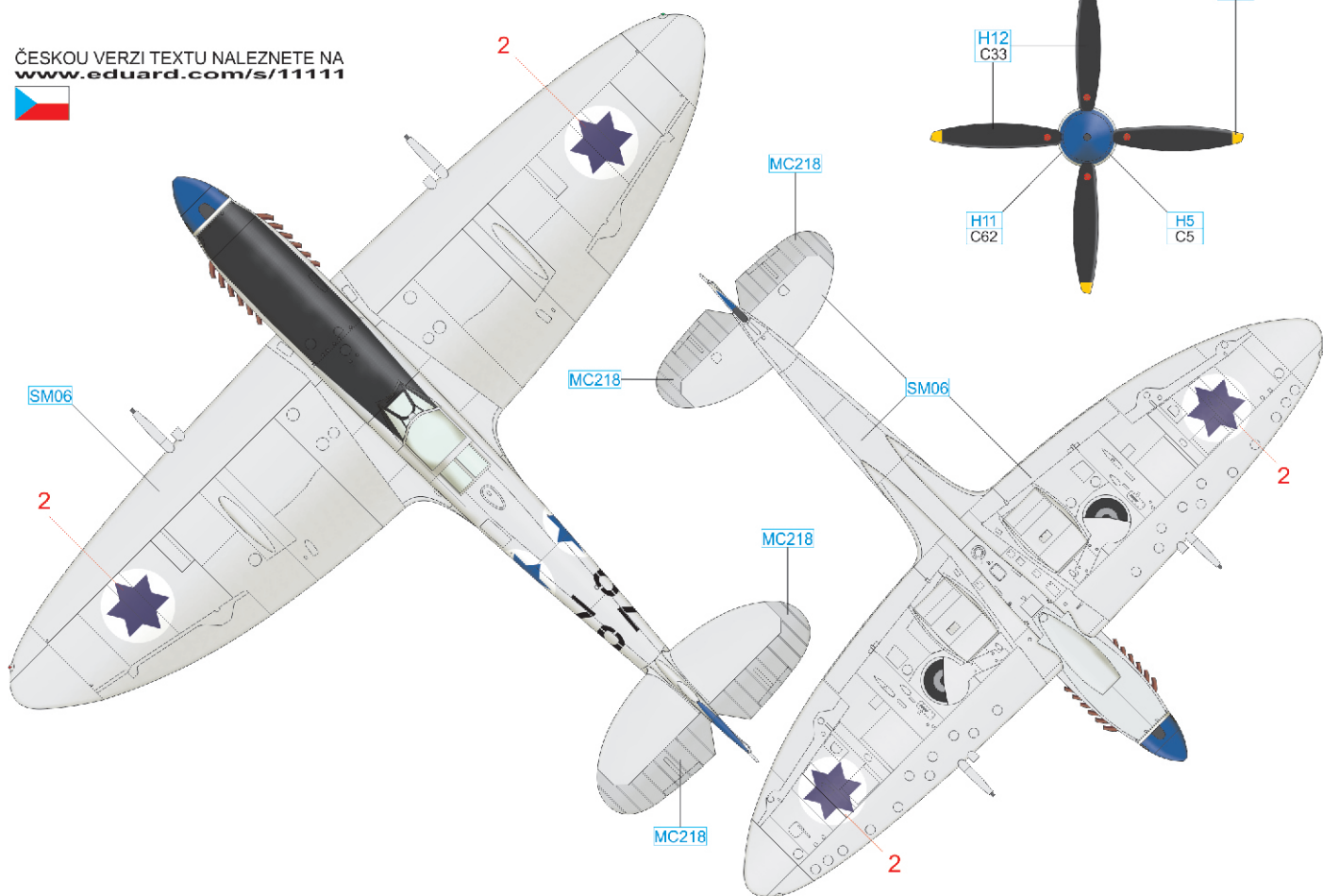

CHROME SILVER	SM06	BLUE	H5 C5
ALUMINIUM	MC218	WHITE	H11 C62
		YELLOW	H4 C4
		RED	H13 C3
		BLACK	H12 C33

# F LF Mk.IXe, 2003 (ex TE531), 105th Tajeset, Ramat David Air Base, Israel, September 1953

This aircraft belonged to a group of three that managed to fly to Israel under Operation Velveta I in September 1948. It served in the Cheyl Ha'Avir with the 101st Tajeset and later with the 105th. It appeared as it is shown here after repairs in 1953 and carries the final form of Israeli Spitfire camouflage (consisting of upper surfaces in dark grey and brown with light grey lowers). The aircraft carries full unit markings, including the unit emblem on the engine cowl, a yellow spinner and a black and yellow rudder. Spitfire 2003 was heavily damaged during landing on December 25th, 1953 by a 107th Tajeset pilot and was written off in March of the following year.

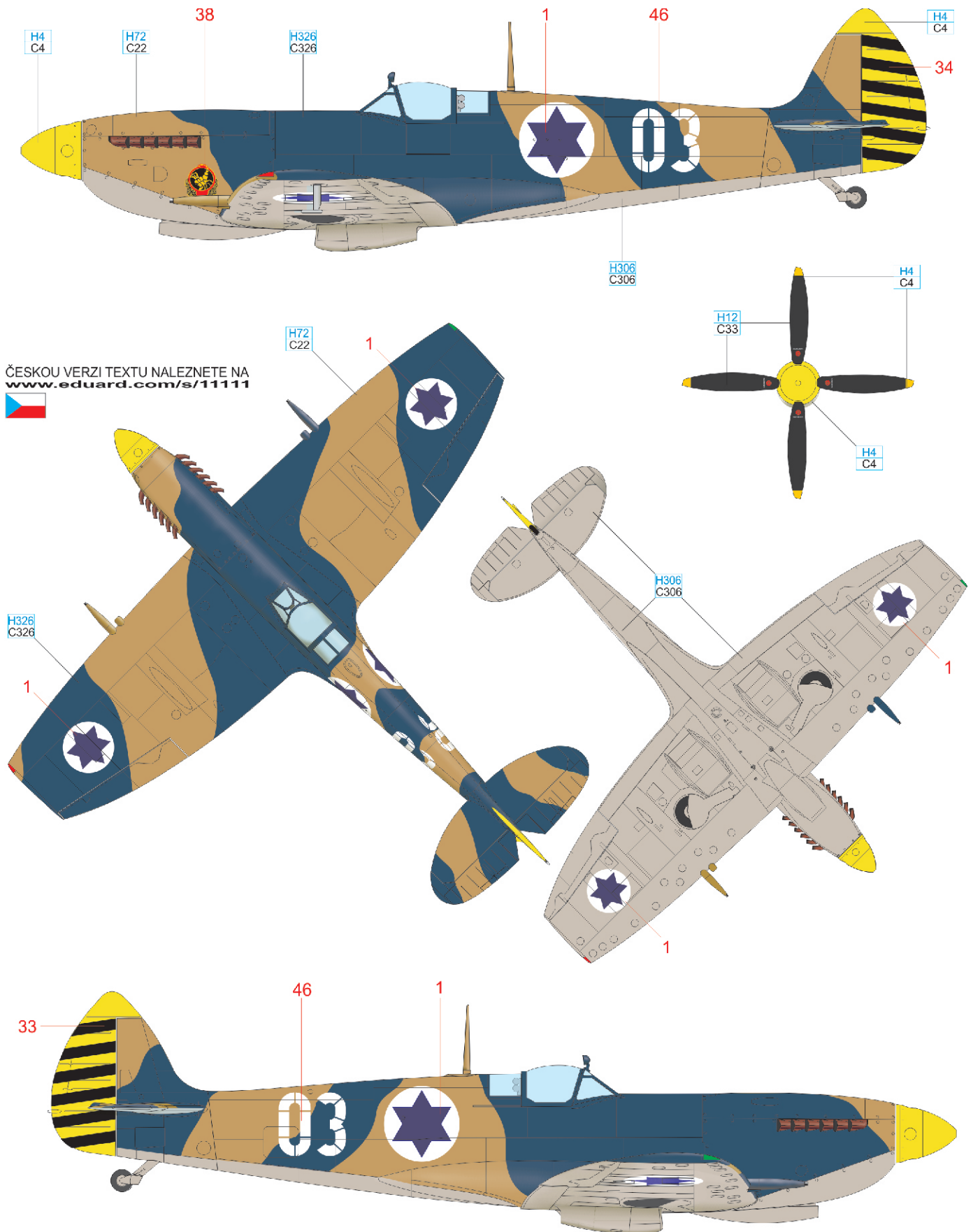

ČESKOU VERZI TEXTU NALEZNETE NA  
www.eduard.com/s/11111



YELLOW	H4 C4	LIGHT GRAY	H306 C306	SAND	H72 C22	DARK BLUE	H326 C326	BLACK	H12 C33
--------	----------	------------	--------------	------	------------	-----------	--------------	-------	------------

eduard

# Spitfire Mk.IXe

# STENCILING POSITIONS

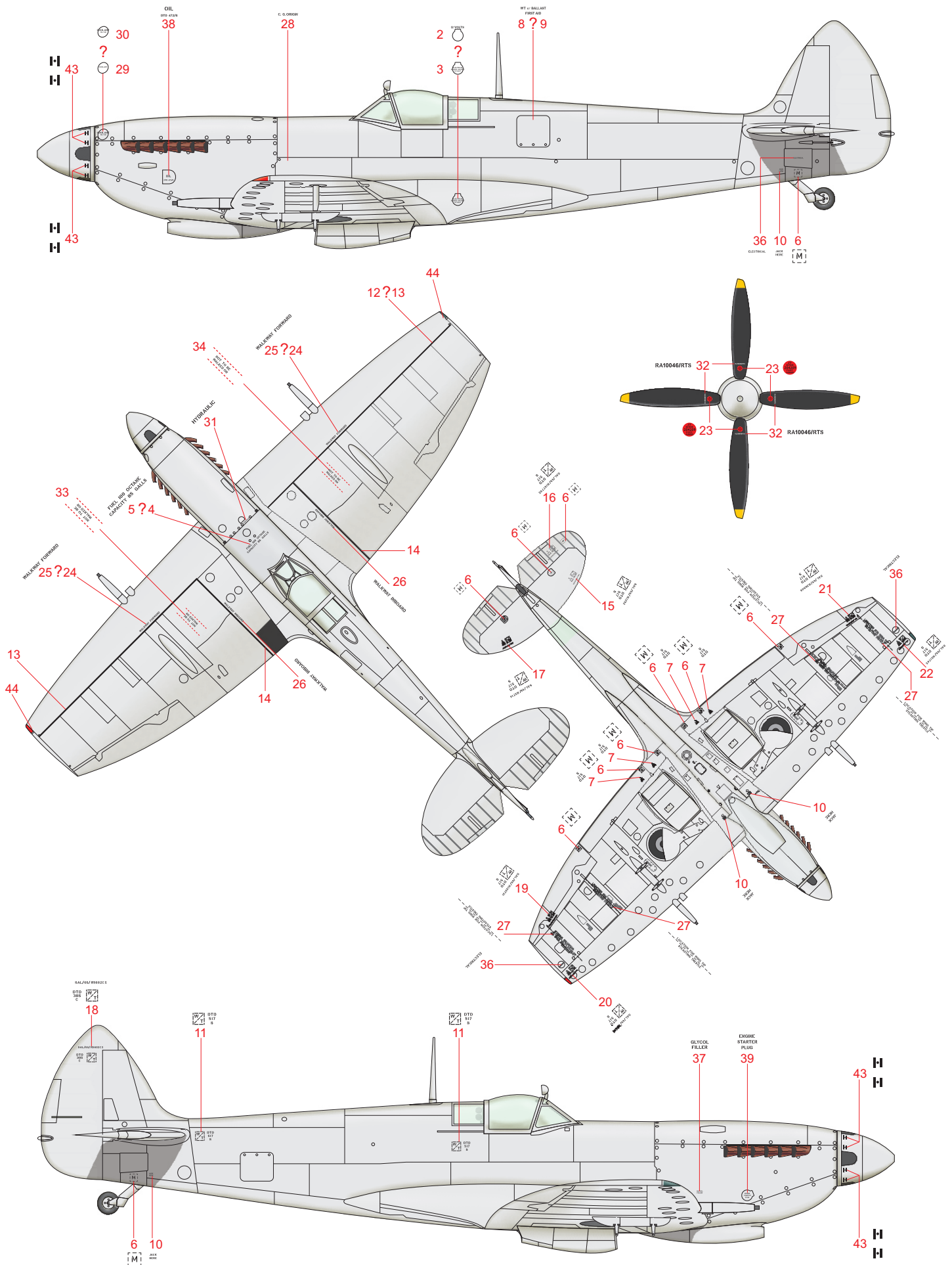

## Related products:

**eduard**  
LIMITED EDITION

- 48765 Spitfire Mk. IXc landing flaps 1/48 (PE-Set)
- 48766 Spitfire Mk. IX surface panels 1/48 (PE-Set)
- 49639 Spitfire Mk. IXc 1/48 (PE-Set)
- 648100 Spitfire Mk. IX cockpit 1/48 (Brassin)
- 648112 Spitfire Mk. IX engine 1/48 (Brassin)
- 648120 Spitfire - radio compartment 1/48 (Brassin)
- 648124 Spitfire undercarriage legs BRONZE 1/48 (Brassin)
- 648306 Spitfire Mk. IX top cowl late 1/48 (Brassin)
- 648334 Spitfire Mk. IXe gun bays 1/48 (Brassin)



648306

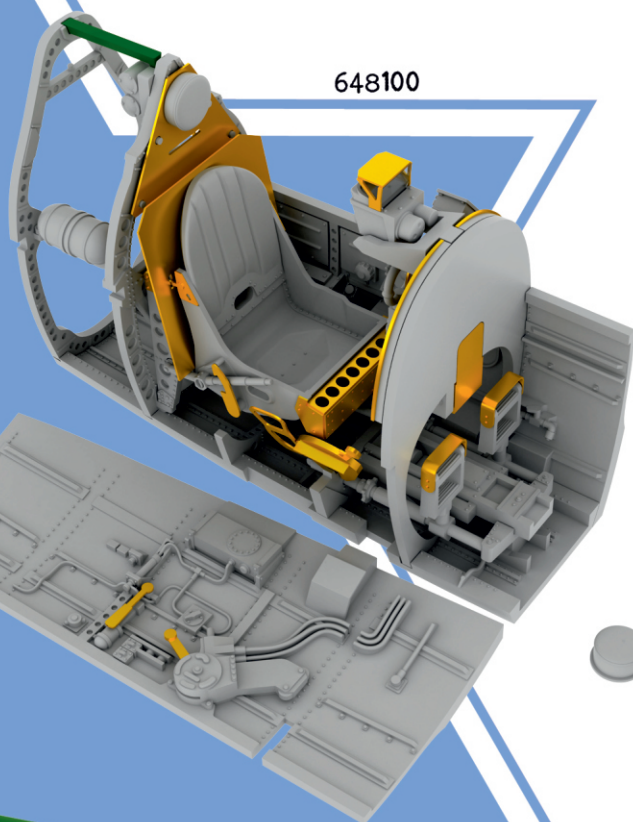

648100

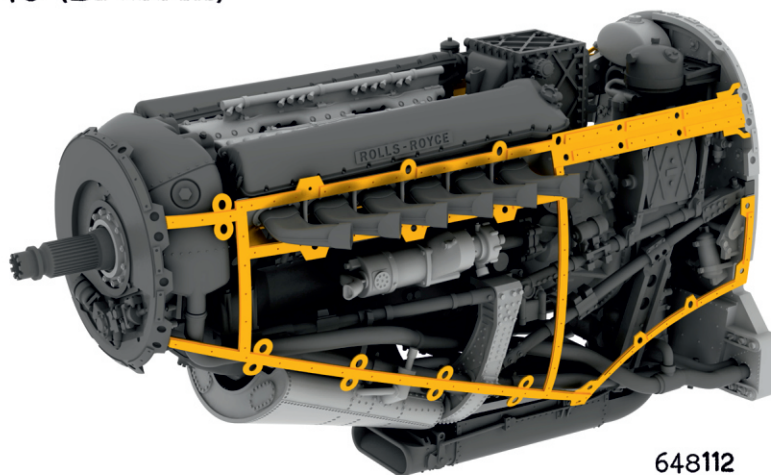

648112

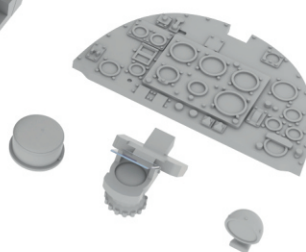

648124

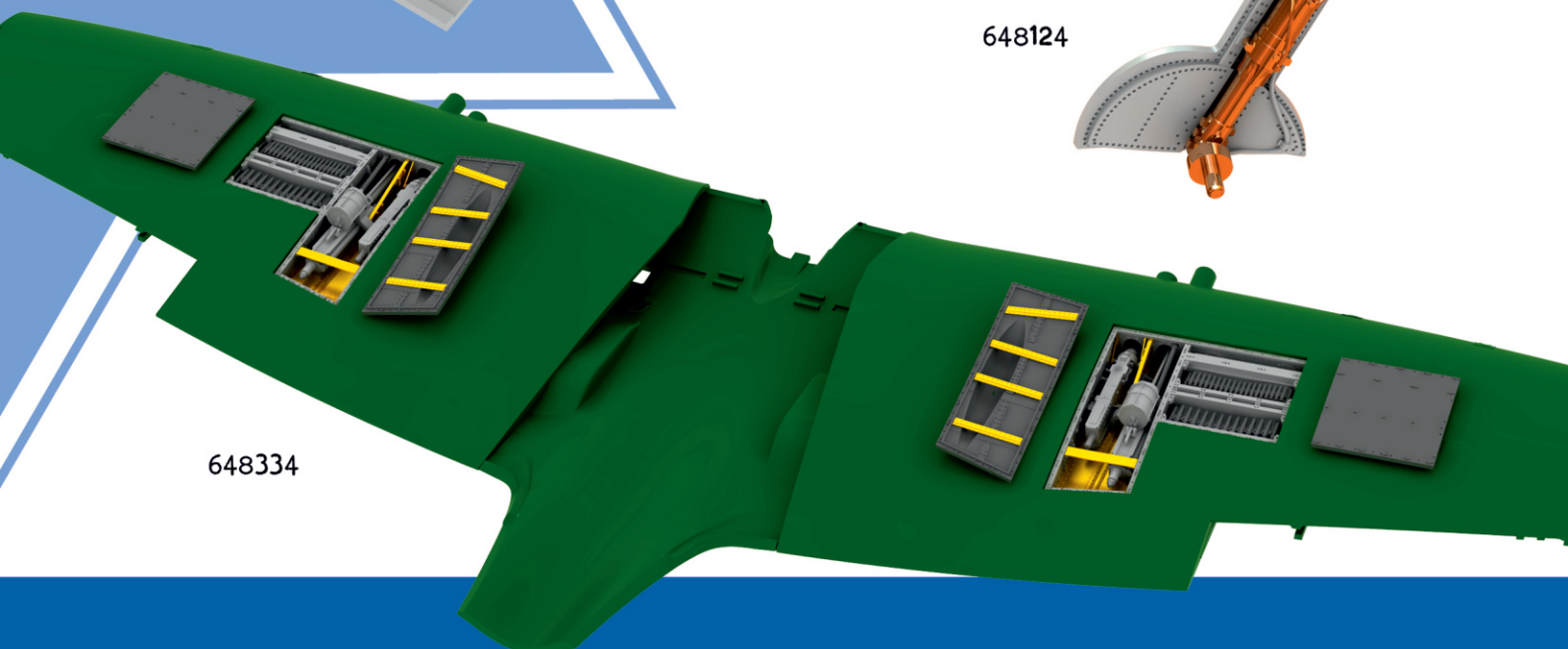
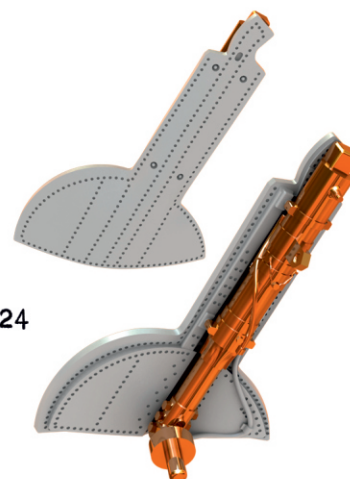

648334