



Russian Self-Propelled Gun SU-152(KV-14)

[April, 1943(early) Production] 1/35 SCALE

Bronco Models 俄军 SU-152 (KV-14) 【1943年4月早期生产型】



The SU-152 was a large self-propelled assault gun-howitzer based on the KV heavy tank chassis. The counter attack at the battle of Stalingrad  showed that the Red Army urgently needed to replace its towed artillery with more modern self-propelled guns. In November 1942 a self-propelled 152mm gun-howitzer was ordered. The KV-2 mounted an M-10 152mm gun, but mounted in a poorly designed turret. Object 236 mounted an ML-20 152mm gun in a low profile gun compartment built on a KV-1s tank chassis. Design work on the pilot vehicle was completed in just 25 days. Named the SU-152 the new self propelled gun entered production at the Chelyabinsk tank factory in January 1943. The SU-152 was an outstanding design and proved not only to be an excellent assault gun, but was also capable of destroying Tiger and Panther tanks at long range. This earned the SU-152 the nickname "Zveroboy" or "Beast Killer". A machine gun was added in the Spring of 1943 for infantry defense, but production ended in December 1943 in favor of the improved ISU-152.

Short Story by Phil Greenwood

Die SU-152 war eine große Selbstfahrlafette, welche auf dem Chassis des schweren KV Panzers basierte. Seit 1943 begegneten den sowjetischen Truppen immer häufiger die schweren deutschen Panzer. Daher forderte man eine Art Mehrzweckwaffe zur Bekämpfung dieser Panzer sowie als Artillerieunterstützung. Desweiteren sollte das Fahrzeug zur Infanteriebegleitung verwendbar sein und dabei Befestigungsanlagen zerstören können. Die ab 1940 eingesetzten KV-2 Typen mit der M-10 152mm Kanone im hohen Turm hatten sich nicht bewährt. Das als Objekt 236 bezeichnete Modell besaß ein ML-20 152mm Geschütz in einem niedrigen Aufbau, welcher auf ein KV-1 Fahrgestell gesetzt wurde. Der Grundentwurf entstand in nur 25 Tagen. Als SU-152 begann im Januar 1943 die Produktion im Werk Chelyabinsk. Der Panzer erwies sich im Folgenden höchst erfolgreich als Sturmgeschütz sowie zur Bekämpfung der Tiger und Panther auf große Distanzen. Im Frühjahr 1943 wurde noch ein MG zur Infanterieabwehr hinzugefügt. Jedoch endete schon nach knapp 700 Stück im Dezember des gleichen Jahres die Produktion zugunsten des besseren ISU-152. 

© Translation Michael Knoblich Academy Europe

SU-152 是一款从 KV 重型坦克底盘发展出来的大型突击自走榴弹炮。斯大林格勒战役暴露出红军迫切需要更现代化的自行火炮替换其拖曳式的火炮。  俄军当局在 1942 年 11 月下达命令要发展自走式的 152 毫米火炮计划。虽然使用中的 KV-2 已装有 M-10 型 152 毫米火炮,但其炮塔设计并不理想。236 号计划就是要将 ML-20 152 毫米榴弹炮装在 KV 1s 的坦克底盘上的低矮炮室内。由开始设计至生产出雏形只短短使用了 25 天的工作时间。该款新式自走榴弹炮于 1943 年 1 月正式命名为 SU-152 并在车里雅宾斯克坦克工厂的车间投入生产。SU-152 的杰出设计,被证明不仅仅是种优越之突击炮,而能够于远距离摧毁德军的老虎和黑豹坦克。这让 SU-152 赢得 "Zveroboy" 或 "野兽杀手" 的绰号。1943 年春天该款自走炮在车前方添置了一挺机枪以防御敌方步兵近距离偷袭,虽然 SU-152 被授好评,可惜该车的改进型却在 1943 年 12 月结束生产了。

CORRECT METHOD FOR APPLYING DECALS : HINWEISE ZUM ANBRINGEN DER DECALS

正确使用水贴纸的方法:

1. Clean model parts surface with wet cloth. Entsprechende Stellen am Modell feucht reinigen.
将需要贴水贴之部位表面擦干净。
2. Cut out the decal parts and dip them in cold water for 15 -20 seconds. Decal ausschneiden und für 15-20 Sek. ins Wasser legen.
将所需之贴纸剪下泡在清水里约15至20秒。
3. Place it on correct position of the model kit. Decal an der richtigen Stelle auflegen.
将湿透之贴纸取出置放于正确之位置旁。
4. Slide off the decal from the base paper on to the model kit surface with a cotton stick. Decal mit Wattestäbchen festhalten und Papier darunter wegziehen.
用棉花棒轻推贴纸表面使其从底纸滑出至模型表面之正确位置。
5. When decal get dry then complete. Decal mit Papiertuch andrücken und trocknen.
待其自然干透后即完成。

ICON INSTRUCTION: 图标说明:



Open Hole
Loch bohren
钻孔



Remove
Abtrennen
切除



x2 2 Sets needed
Vorgang wiederholen
同样的制作二组



Bend
Biegen
曲折



Optional
Auswahl
可以选择采用



Apply Decal
Decal anbringen
贴水贴纸



Instant Glue For Metal
Sekundenkleber verwenden
瞬间接着剂,金属用



Fill Hole
Verspachteln
把孔填平



Do not cement
Nicht kleben
不用粘合

COLOR SUGGESTION: FARBTABELLE: 涂装指引:

Color	涂料表	MR. Hobby	Hobby Color	Humbrol	Tamiya
Steel	Stahl 黑铁色	H-18	C-28	53	/
Wood brown	Dunkelgrun 木棕色	H-37	C-43	/	/
Silver	Silber 银色	H-8	J-8	11	X-11
Flat white	Matt Weiss 消光白	H-11	C-62	34	XF-2
Flat black	Mattschwarz 消光黑	H-12	C-33	33	XF-1
German gray	Deutsch grau 德国灰	H-32	C-40	92	XF-63
Tyre black	Reifenschwarz 轮胎黑	H-77	C-137	85	/
Semi-gloss black	Schwarz Seidenmatt 半光黑色	/	C-82	/	/
Oliver darb	Braun-Olive 橄榄褐	H-304	C-304	116	X-62
White	Weiss 白色	H-1	C-1	/	X-2

READ BEFORE ASSEMBLING: VOR ZUSAMMENBAU LESEN: 组装必读:

- Carefully Study instruction before assembling. Anleitung studieren und verständlich machen. 组装前请阅读清楚制作指引。
- Keep plastic model glue and tools away from children. Kleber, Farben, Werkzeuge und Plastiktüten von Kindern fernhalten. 胶水,油漆及工具勿让小孩接触。
- Do not use cement or paint near open flame or sparks. Kleber/Farbe nicht in Nähe von offenen Flammen. 胶水及油漆勿接触火种。
- Do not work in closed room. Nur in ausreichend belüfteten Räumen arbeiten. 勿在密封地方制作模型。

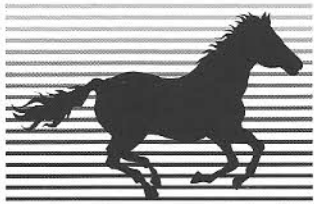

BRONCO

Bronco Models

Copyright © 2013

Made in China

中国制造

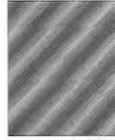

No use parts
不要部件

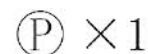
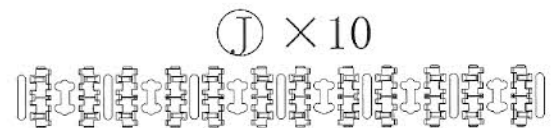
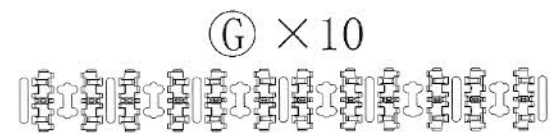
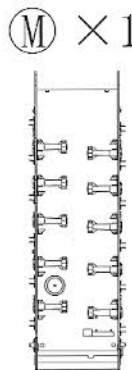
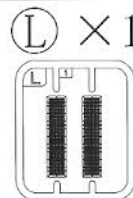
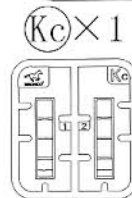
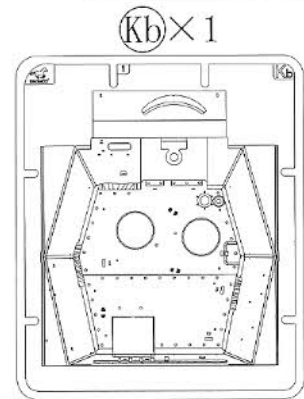
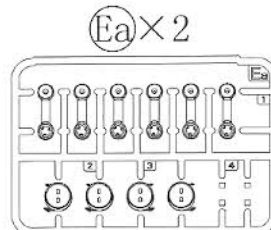
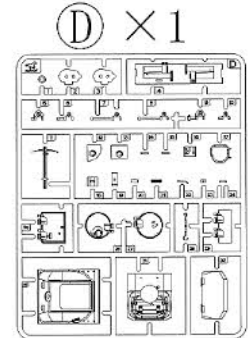
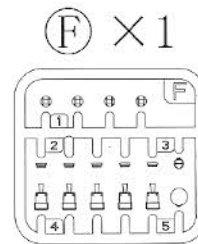
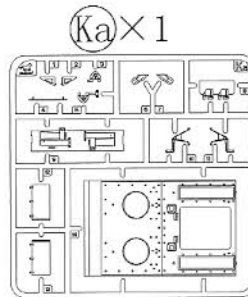
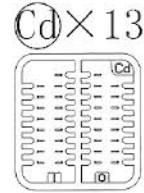
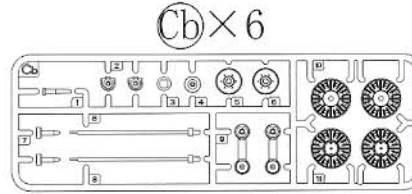
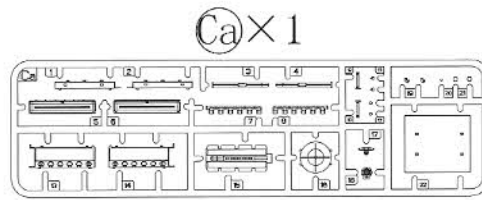
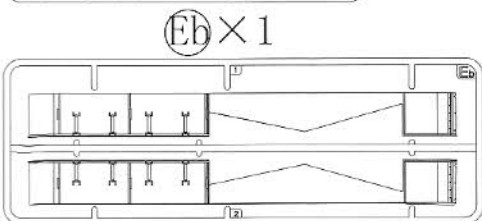
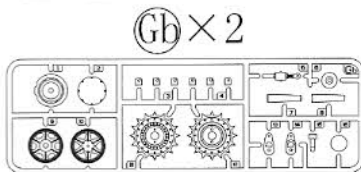
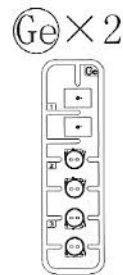
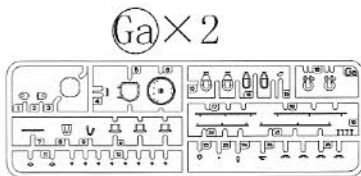
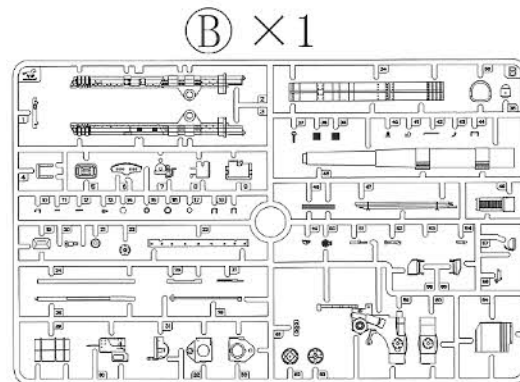
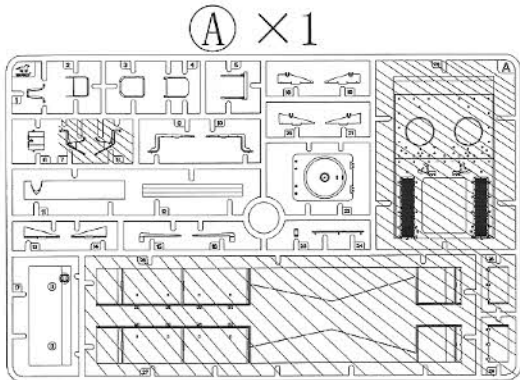

Copper wire
铜丝 × 2



DECAL × 1

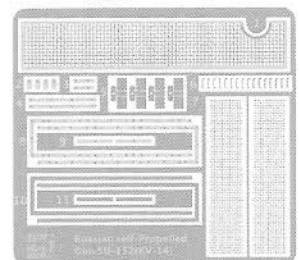

CB35113

ILLUSTRATION 图示说明:

Caution:

This kit contains a lot of small accurate parts, please carefully to read before to assembly.
此套件包含不少精细零件, 请在制作前先翻阅说明书了解清楚。

1

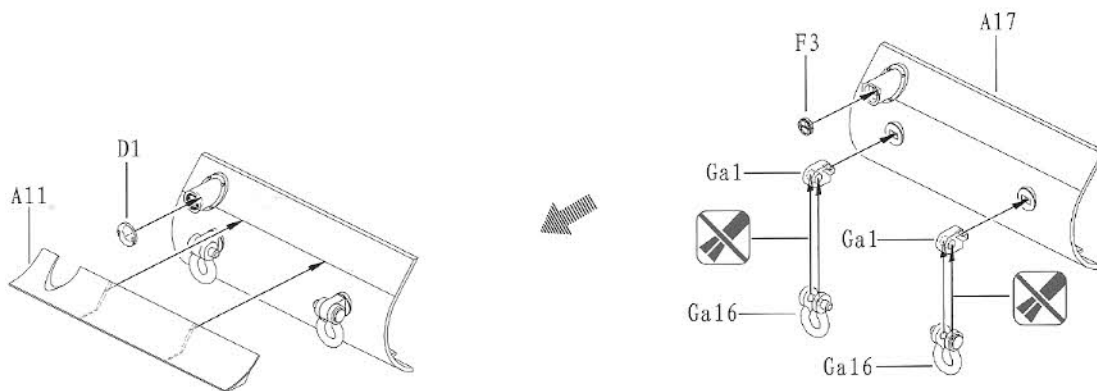

1

2

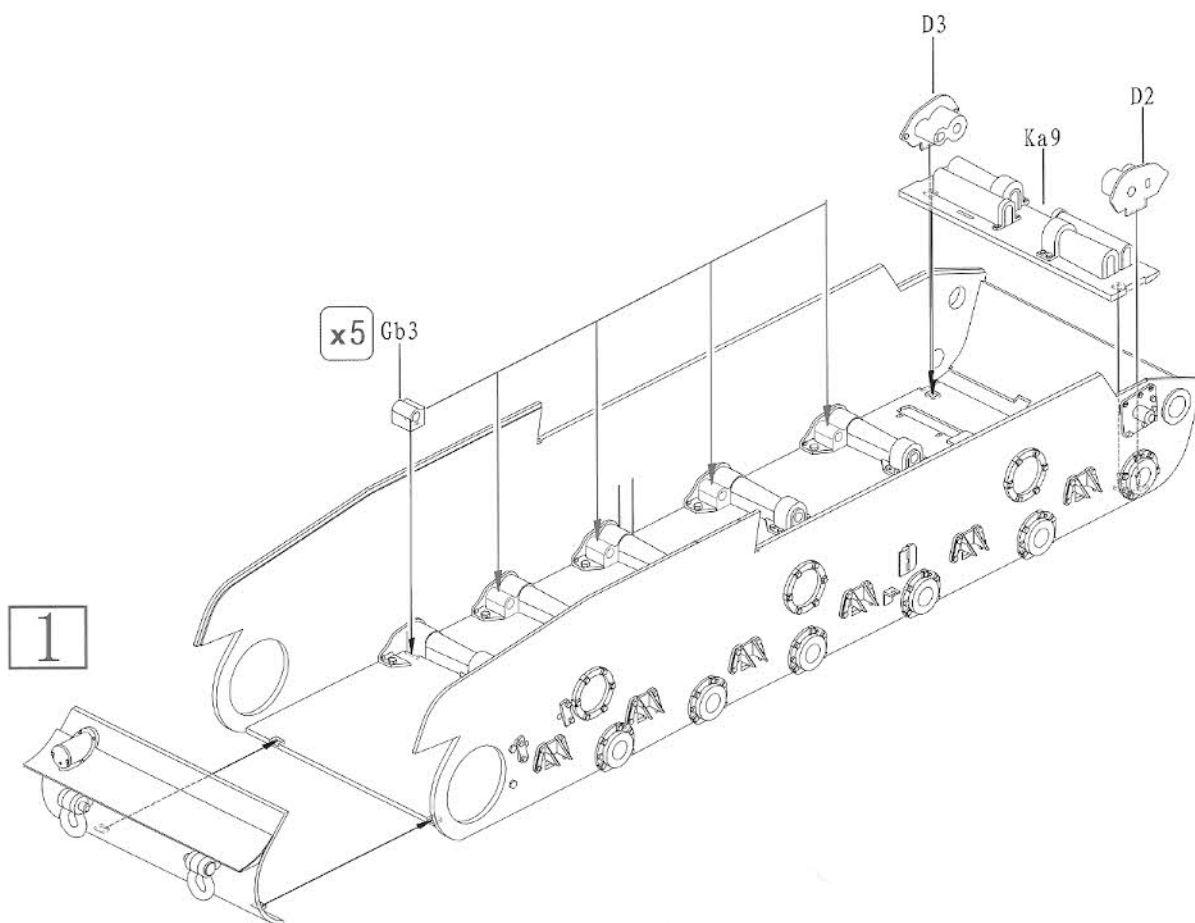

3

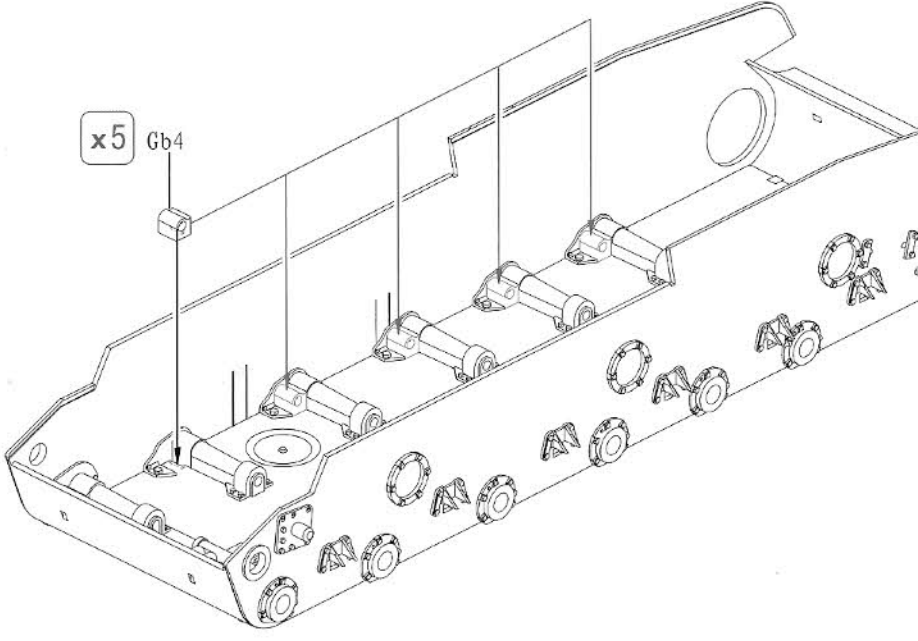

4

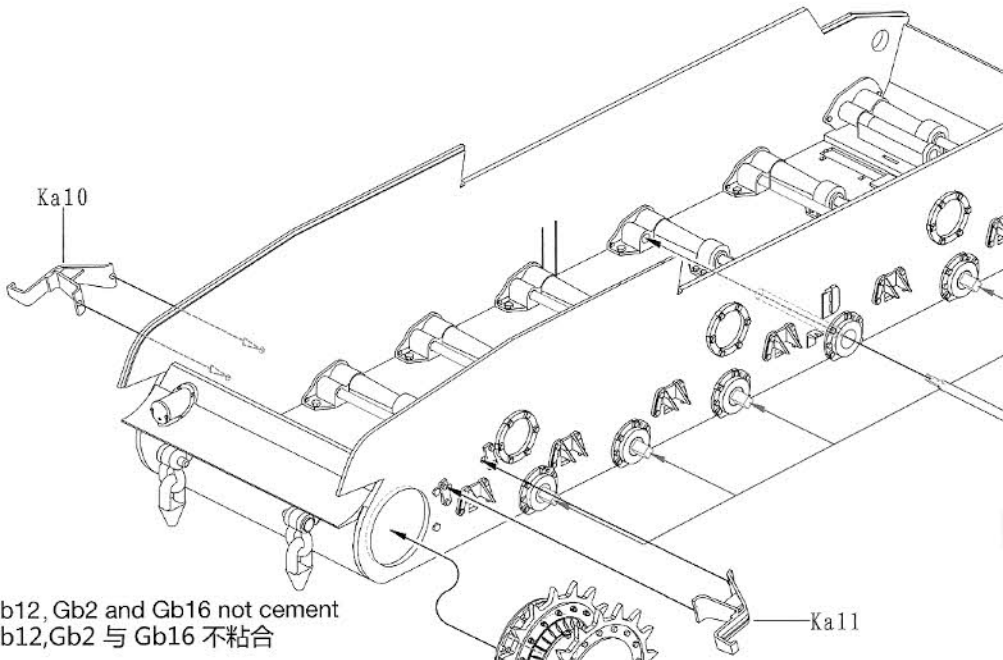

★ Gb12, Gb2 and Gb16 not cement
 Gb12, Gb2 与 Gb16 不粘合

Both sides
 对侧相同

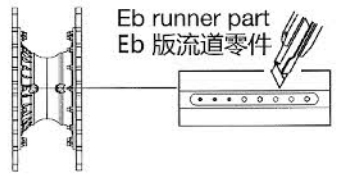
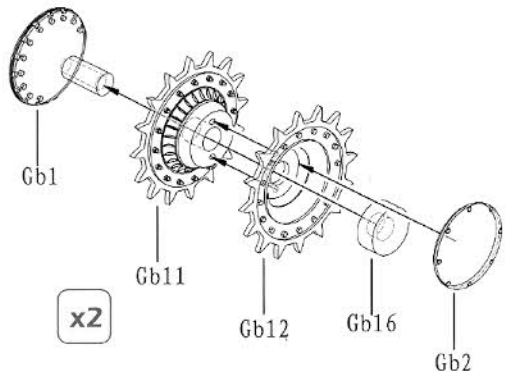
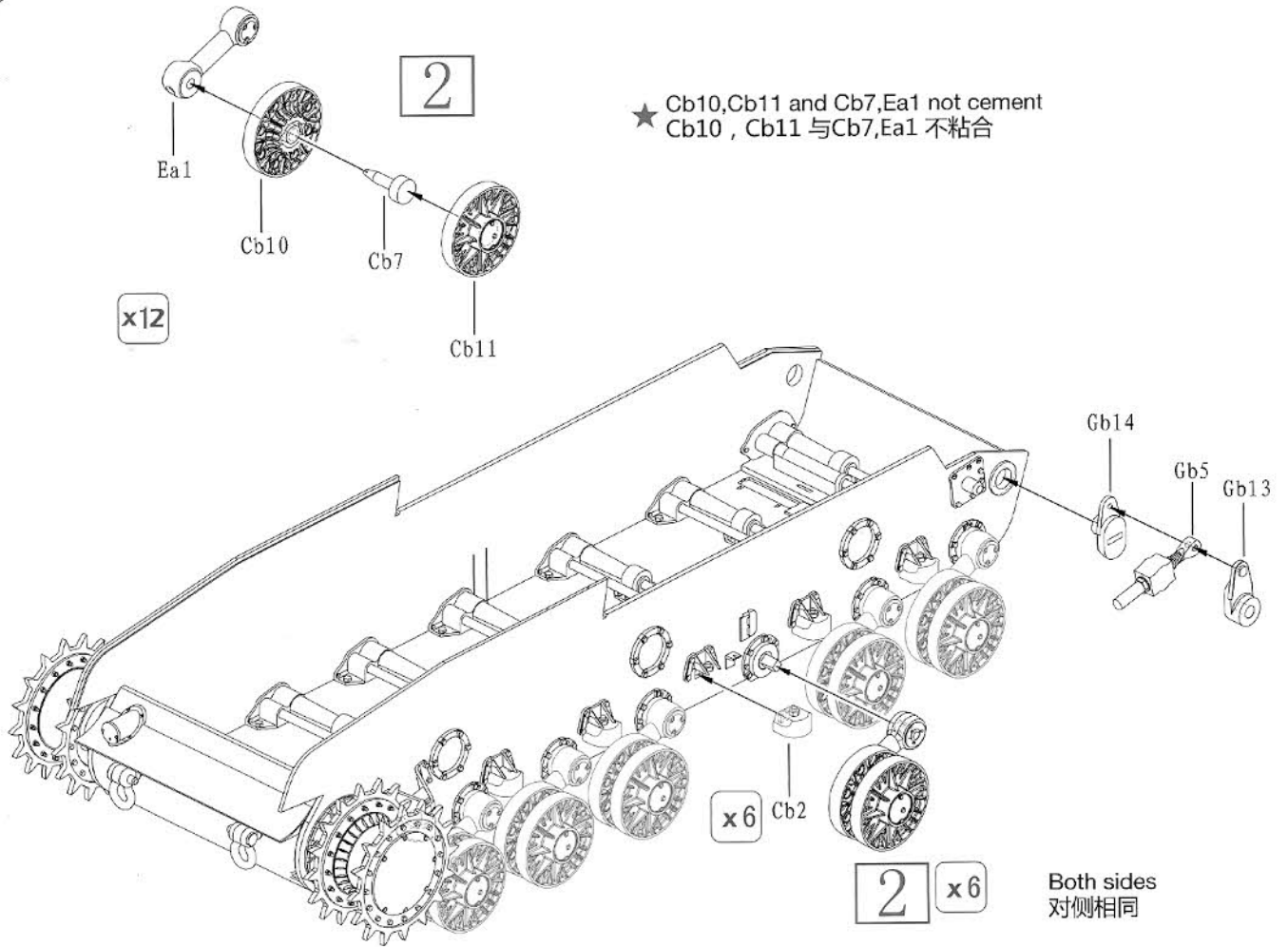
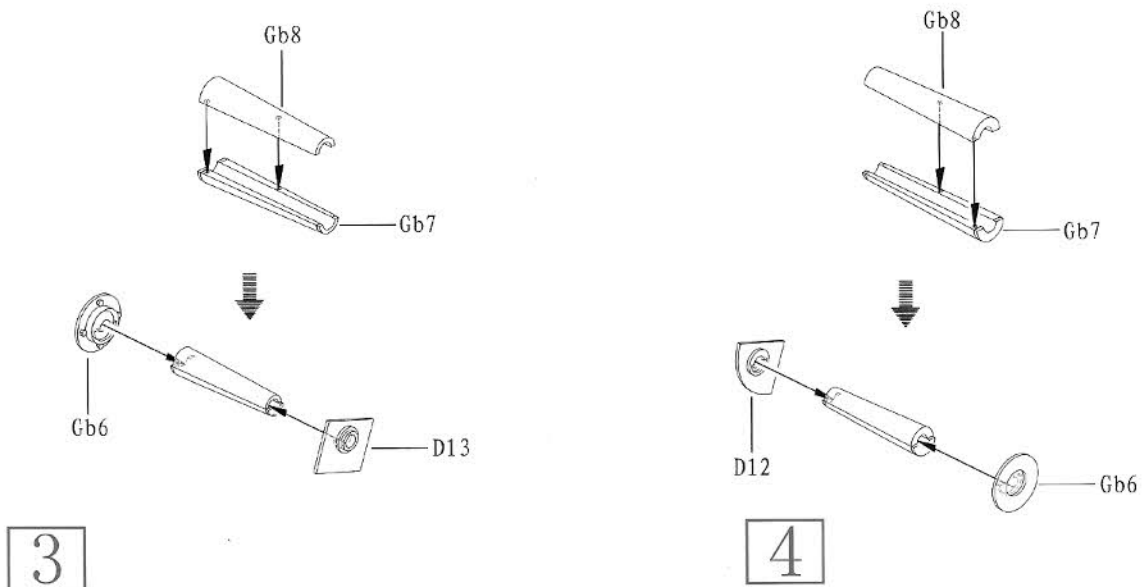

ILLUSTRATION 图示说明:

5



6



7

★ Cb5,Cb6,Cb3 and Cb1,Cb4 not cement
Cb5,Cb6,Cb3 与Cb1,Cb4 不粘合

Close position
关闭状态

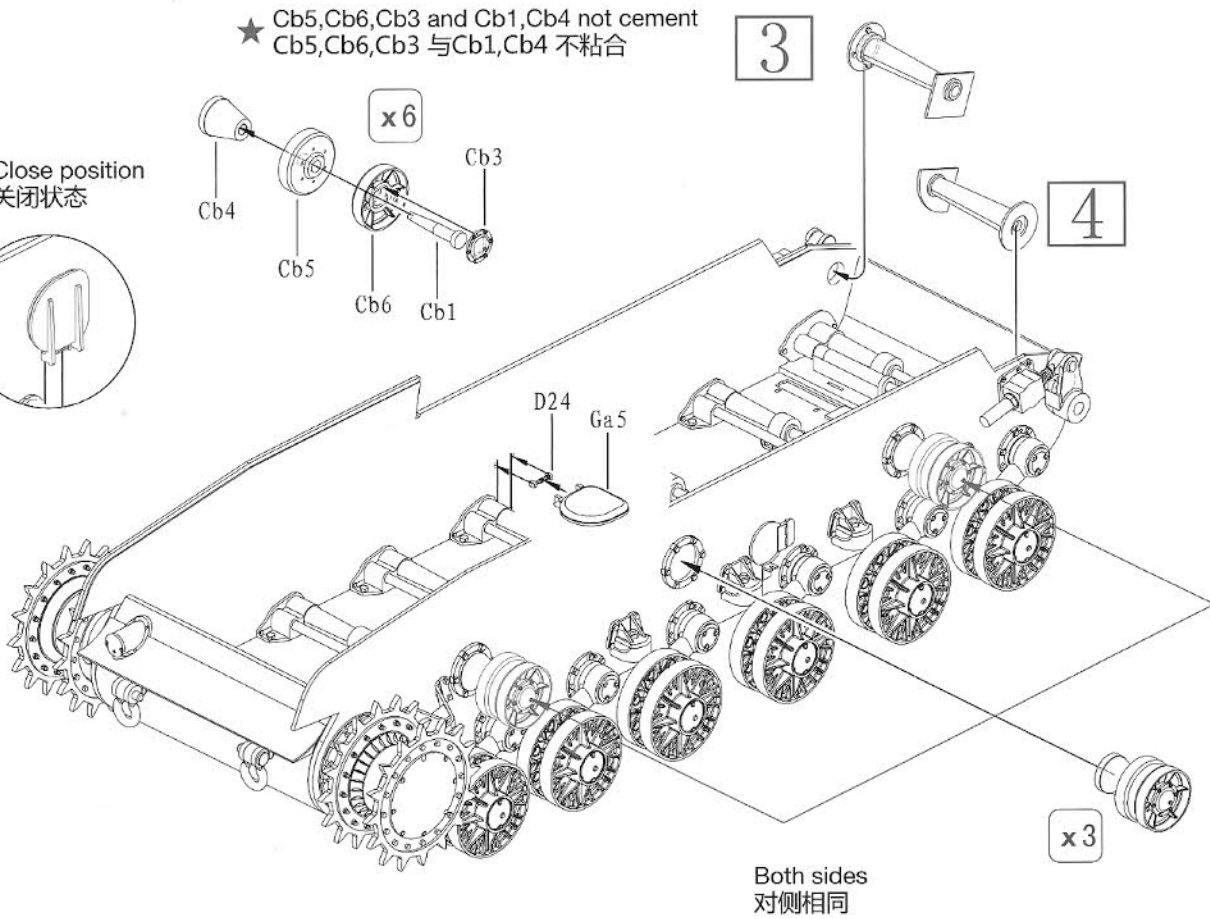
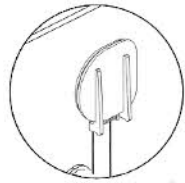

8

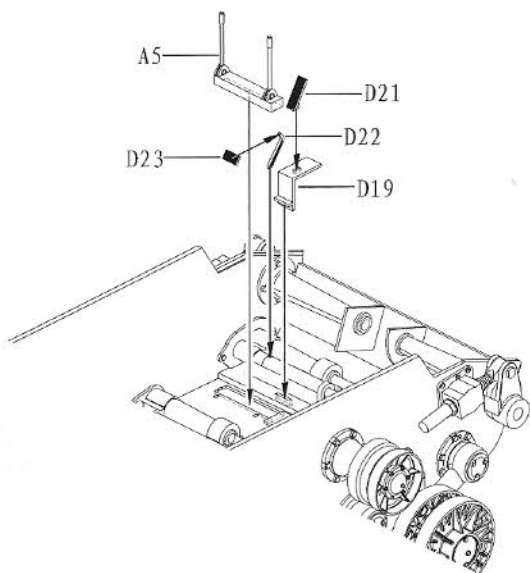

9

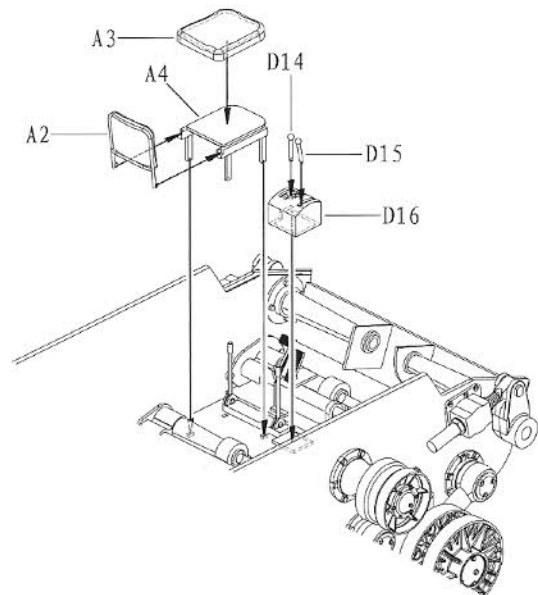

10

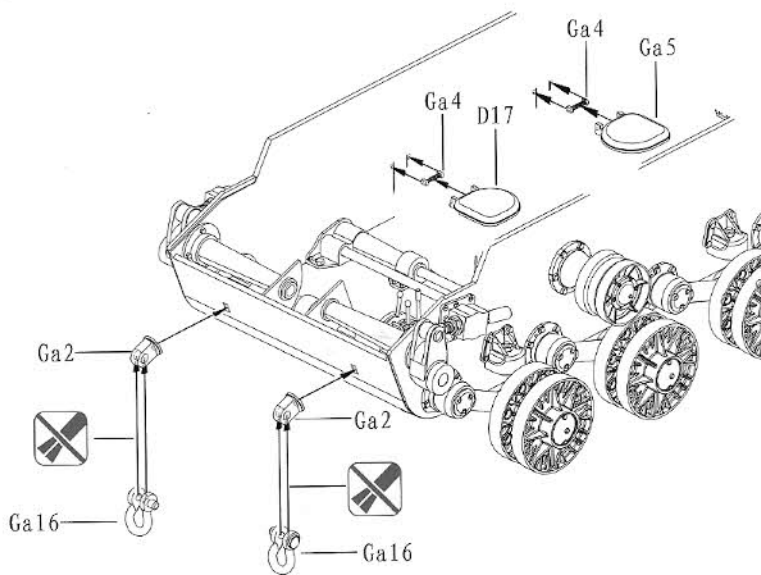

Close position
关闭状态

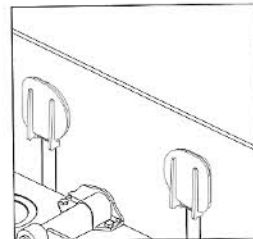

11

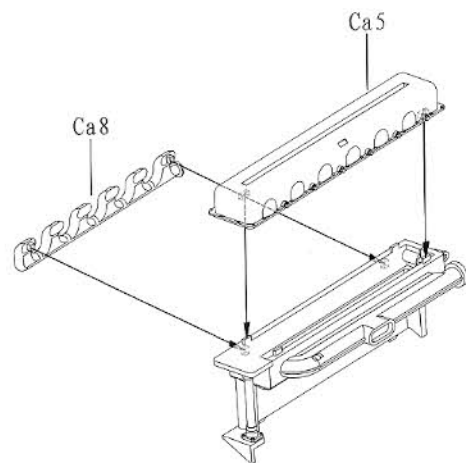
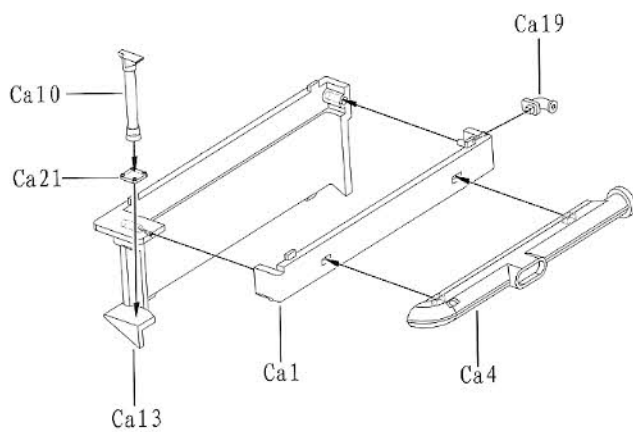

5

12

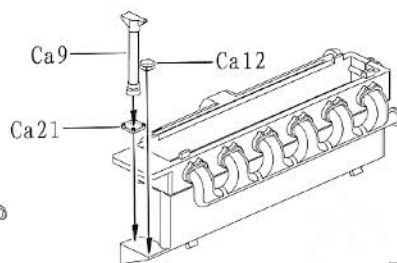
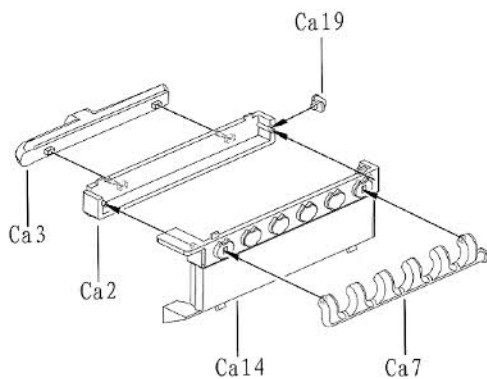

6

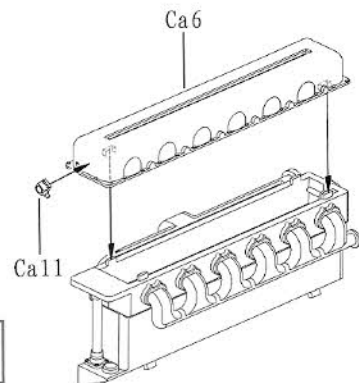

13

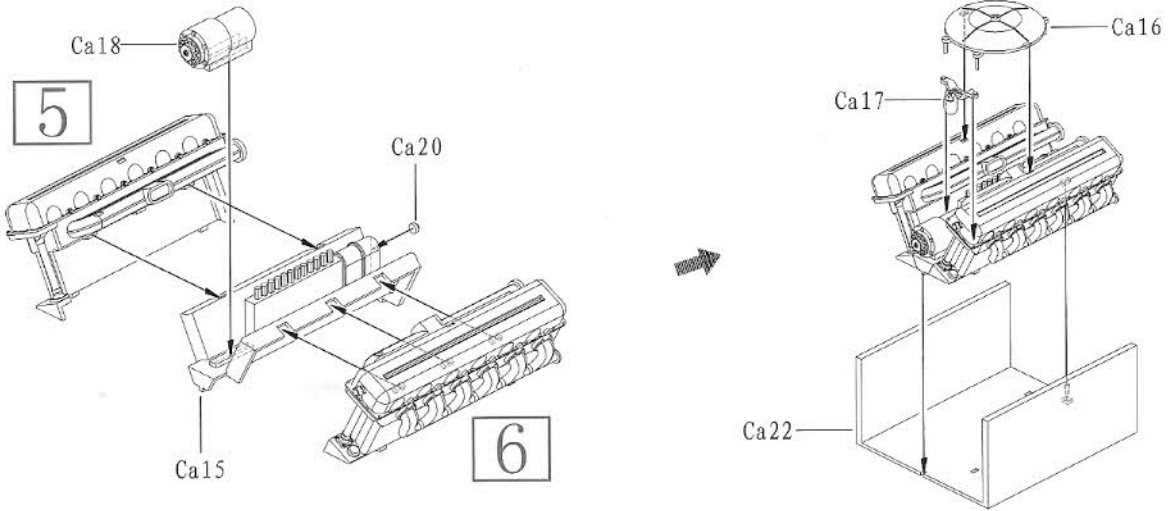

14

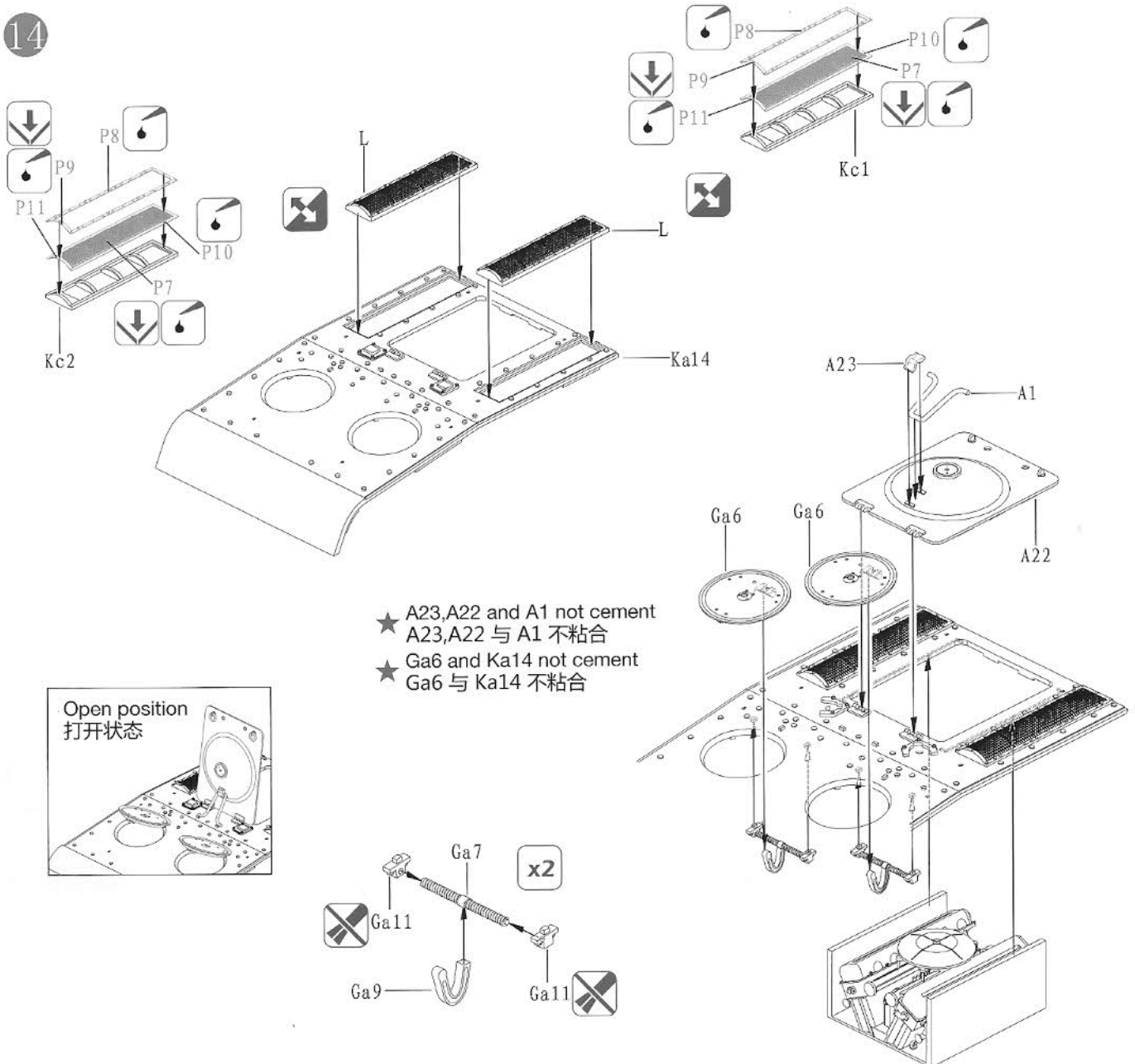

15

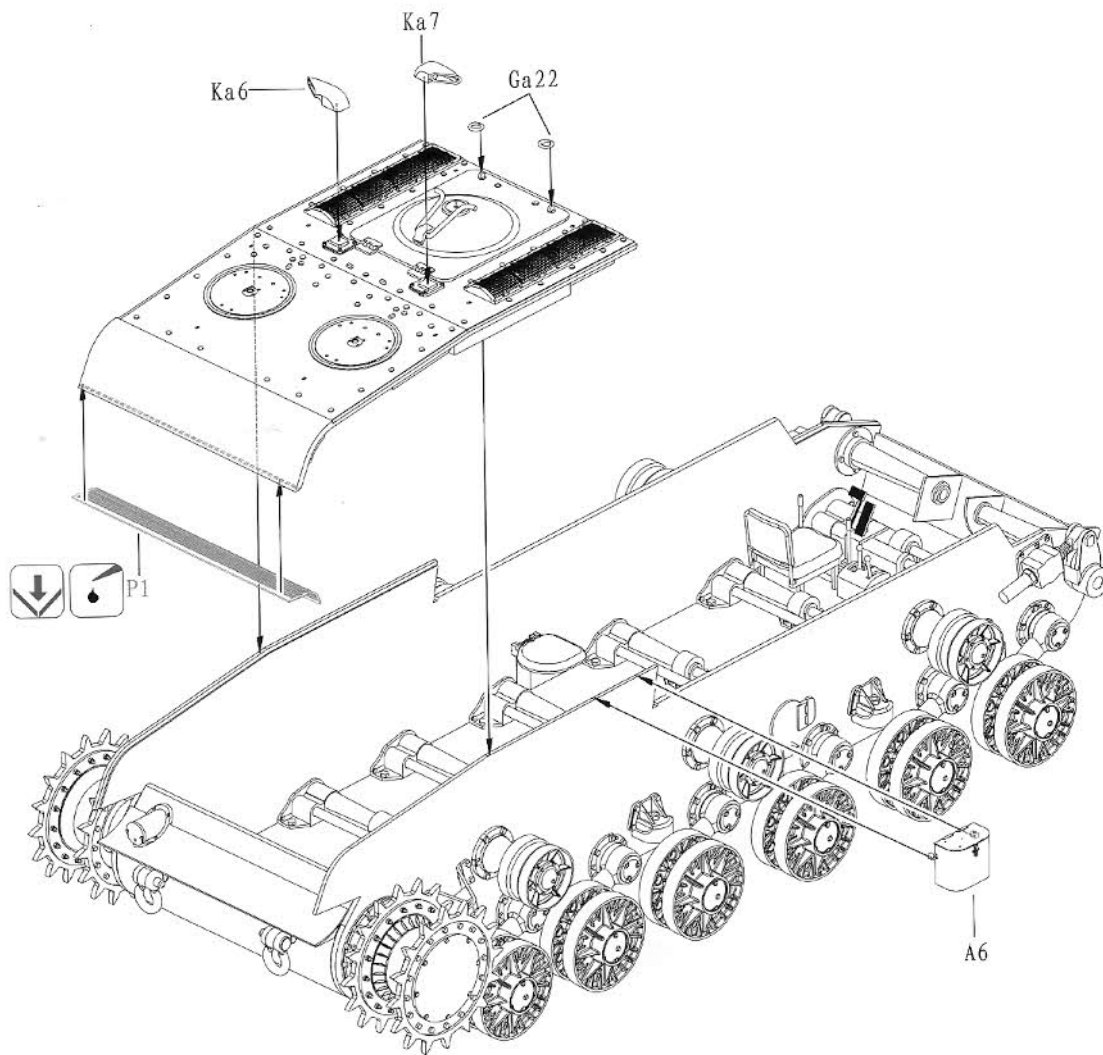

16

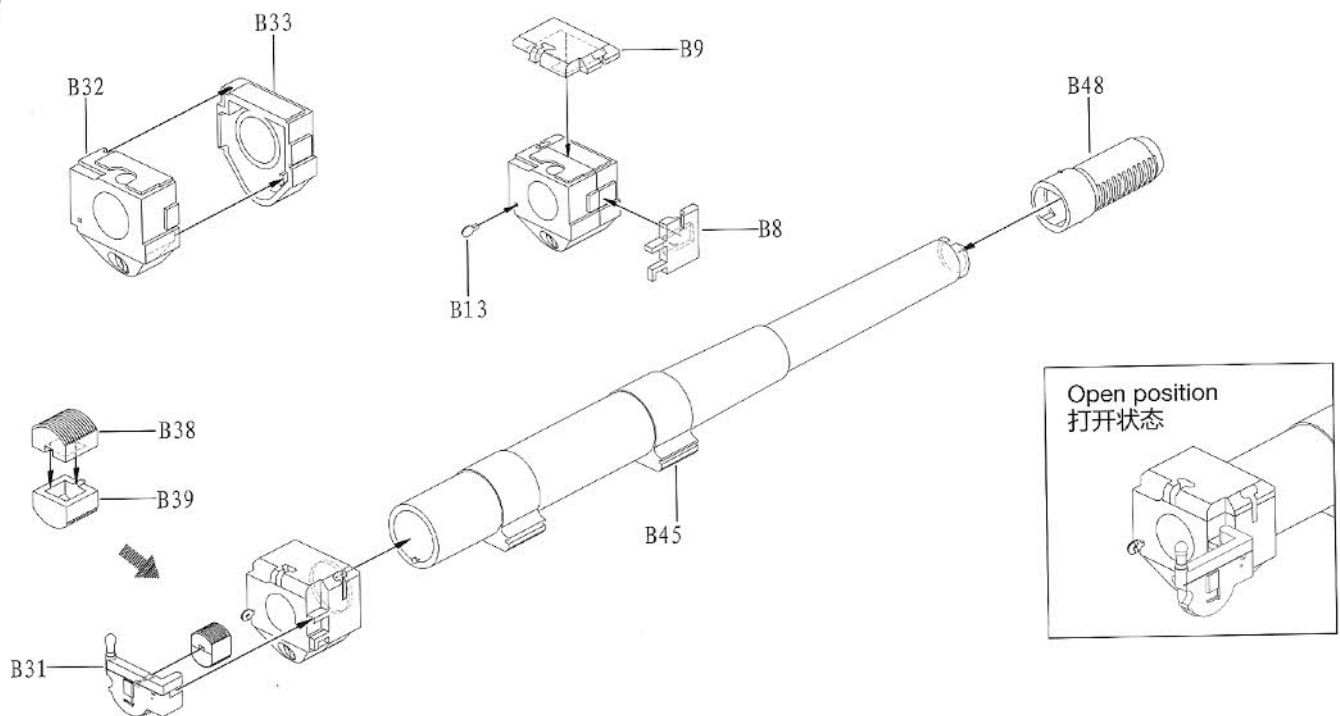

17

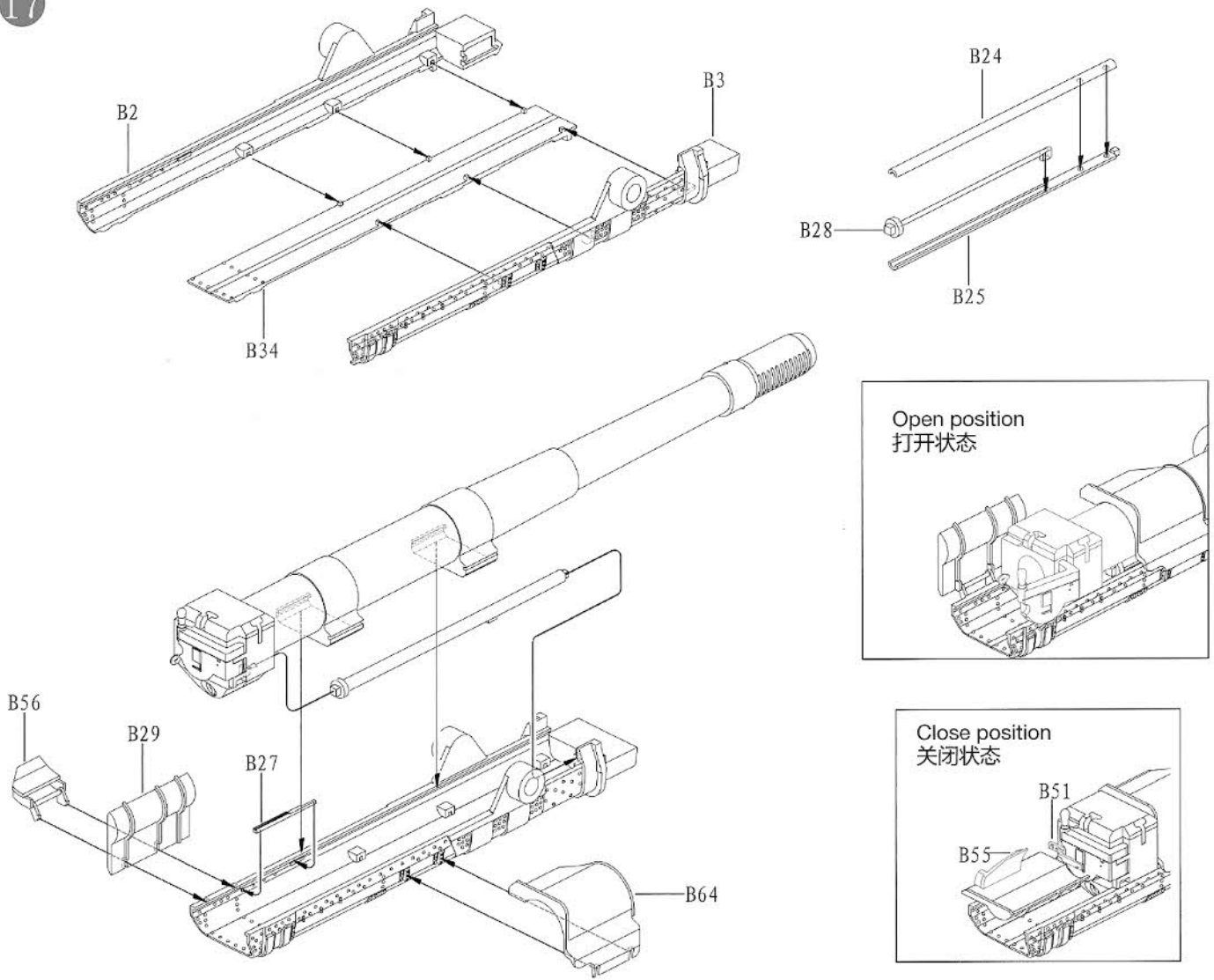

18

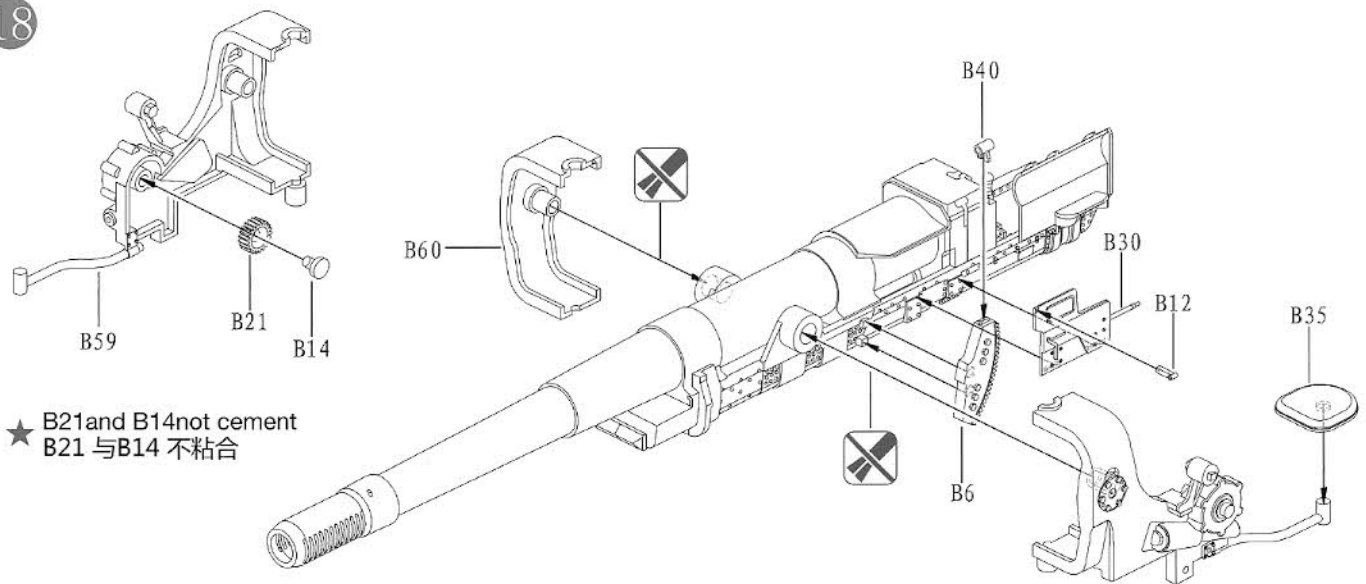

19

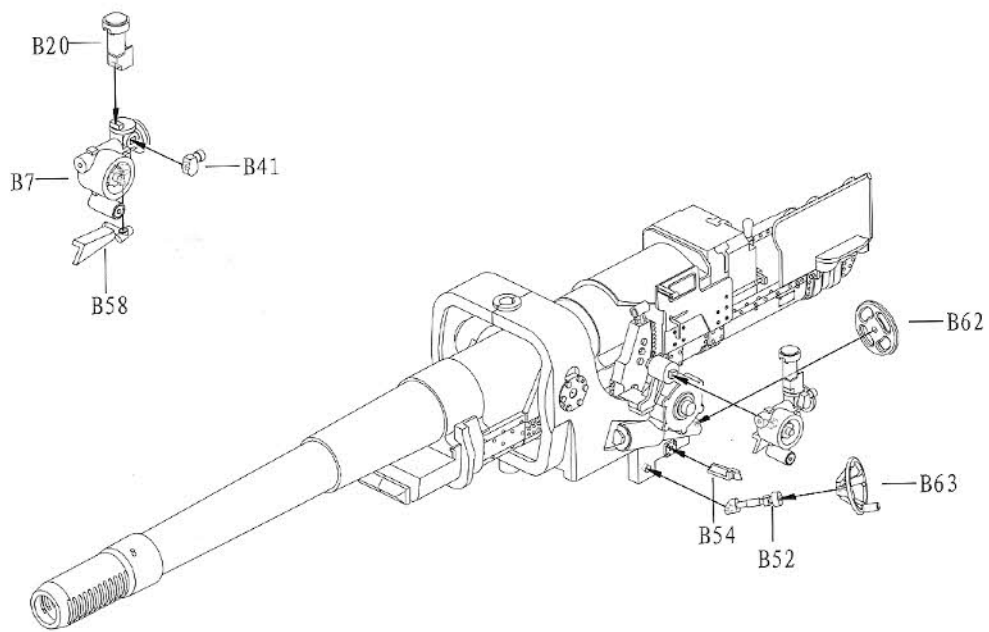

20

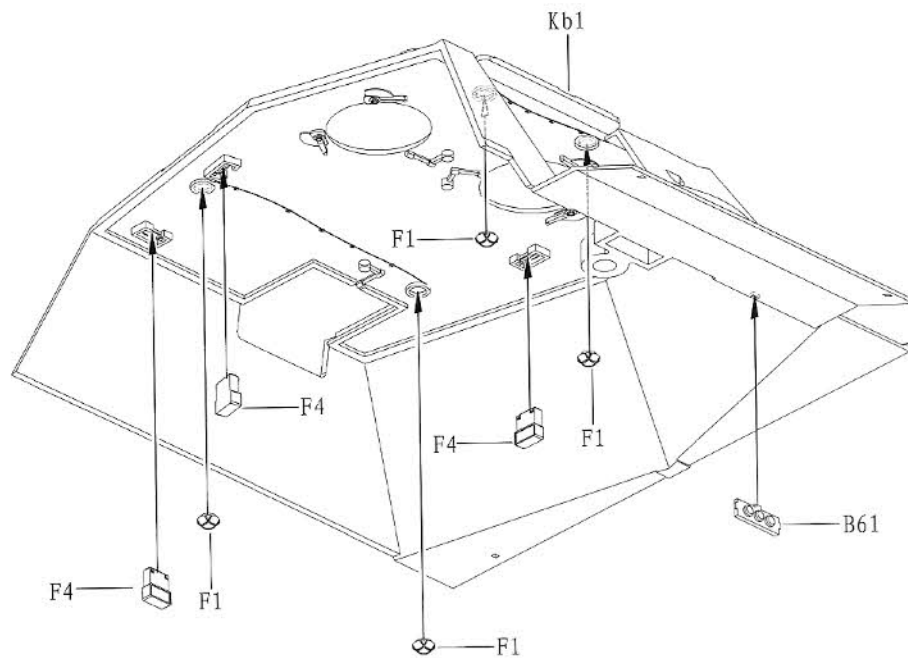

21

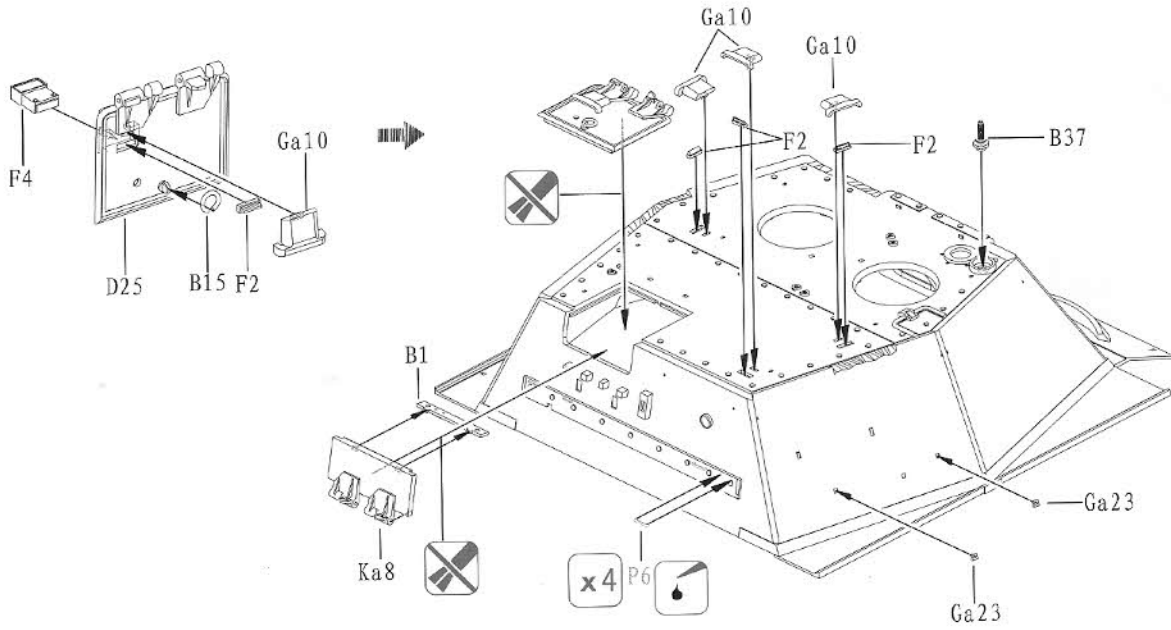

22

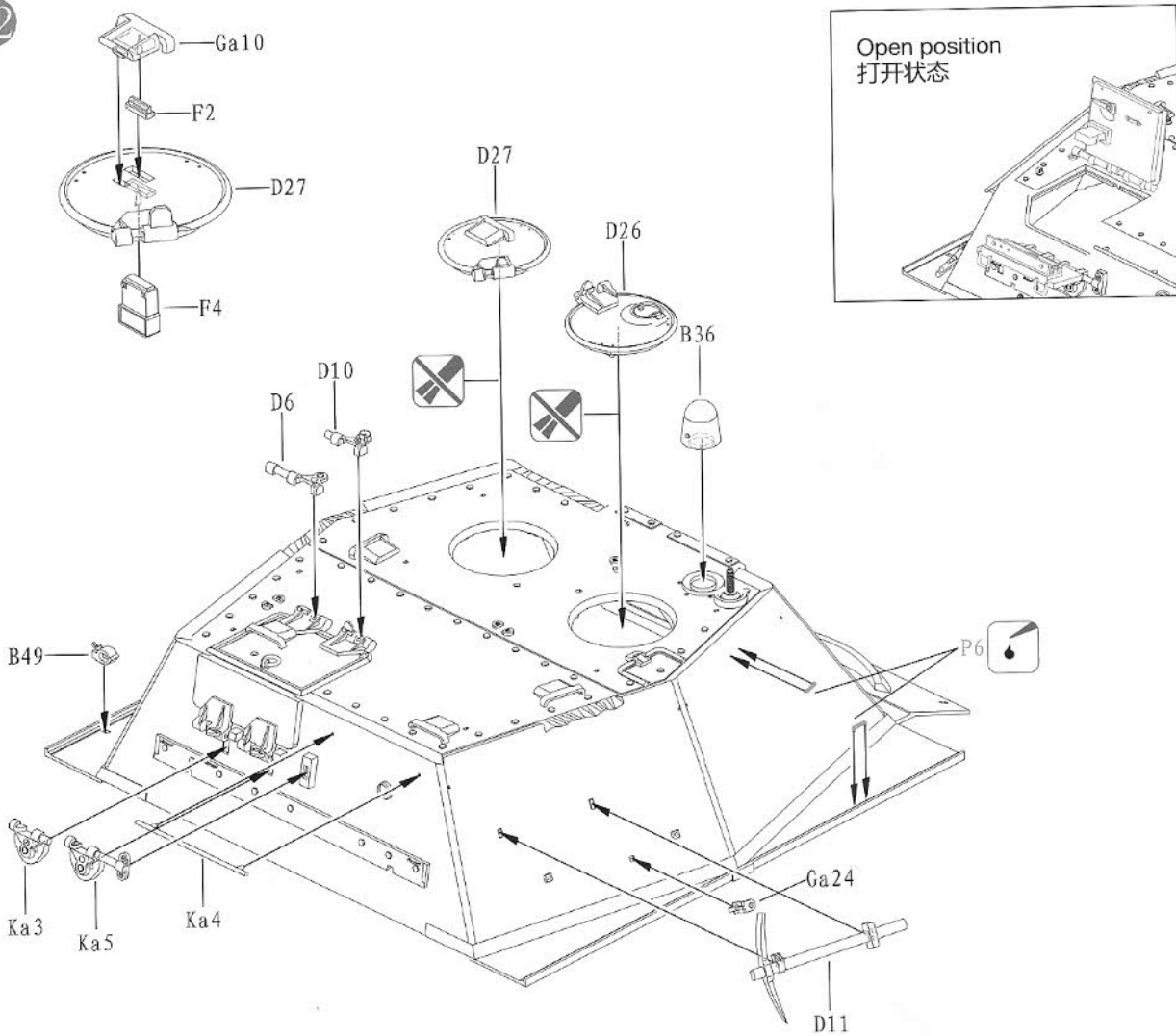

23

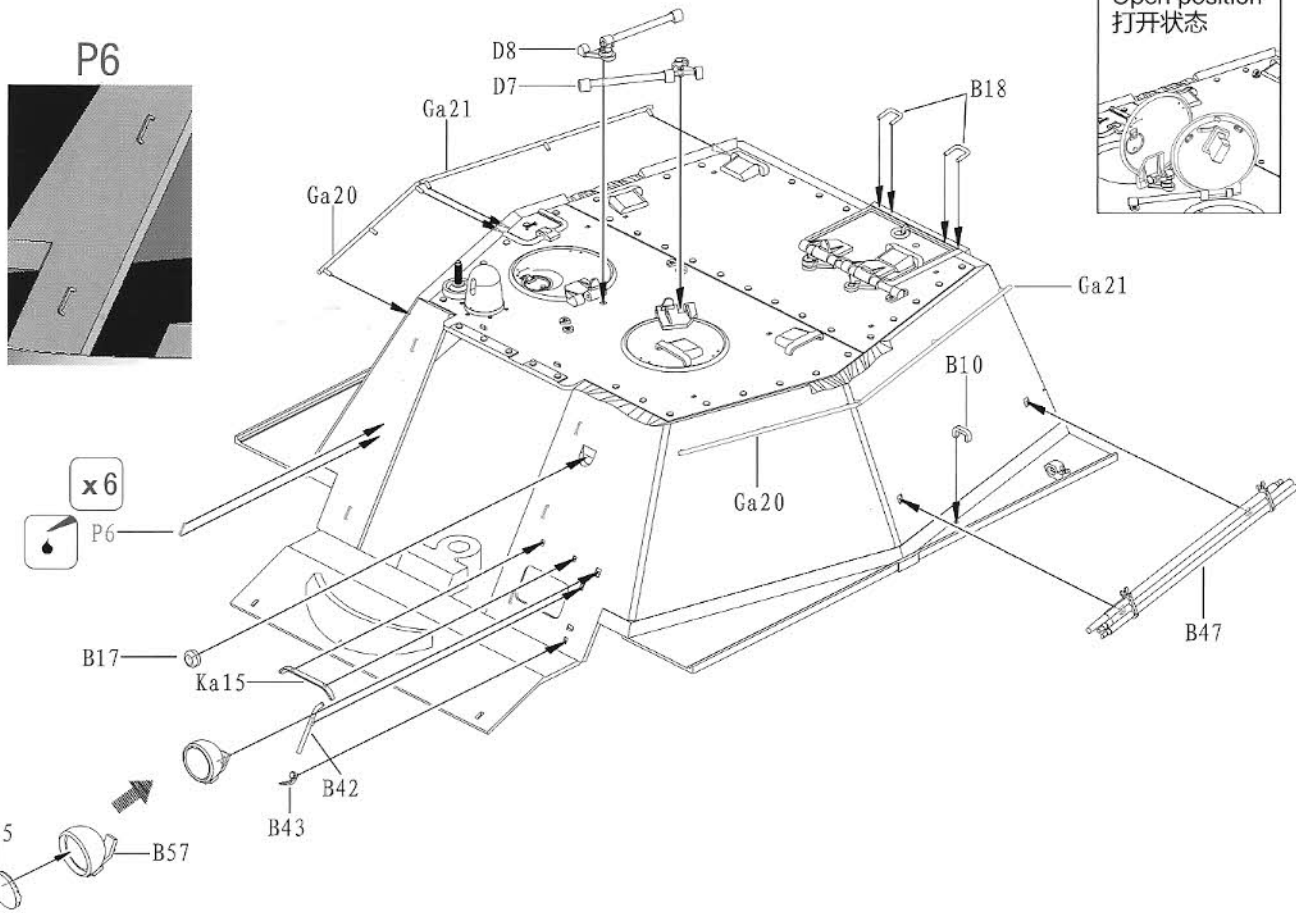

24

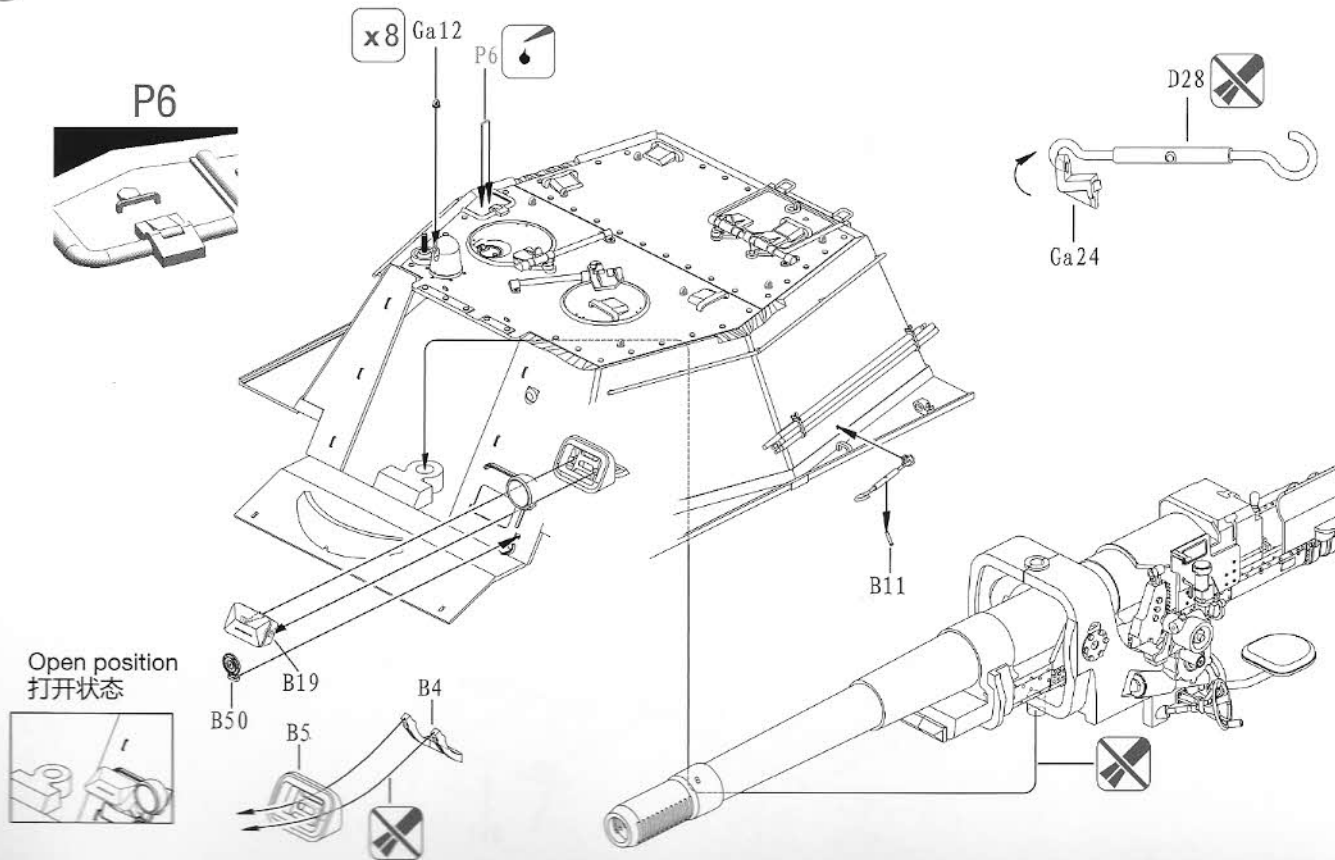

25

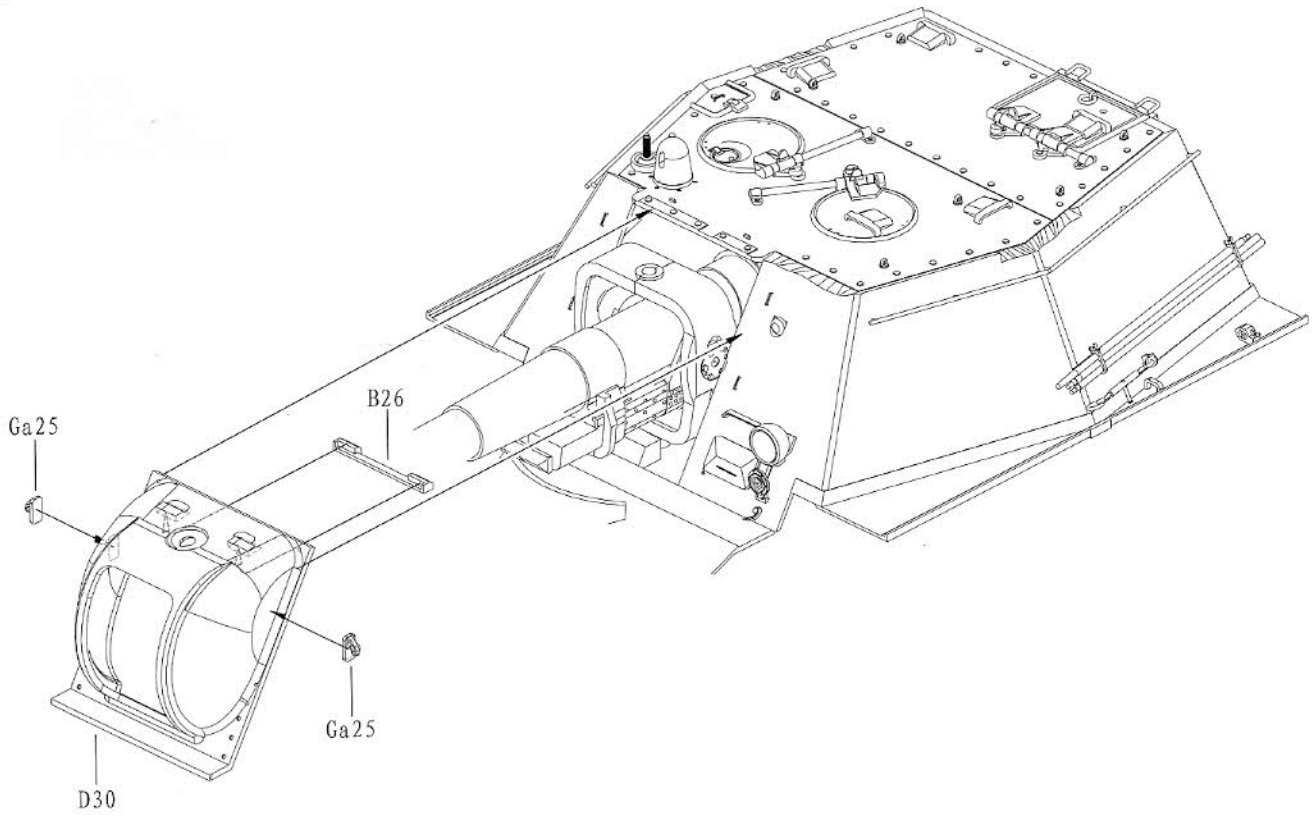

26

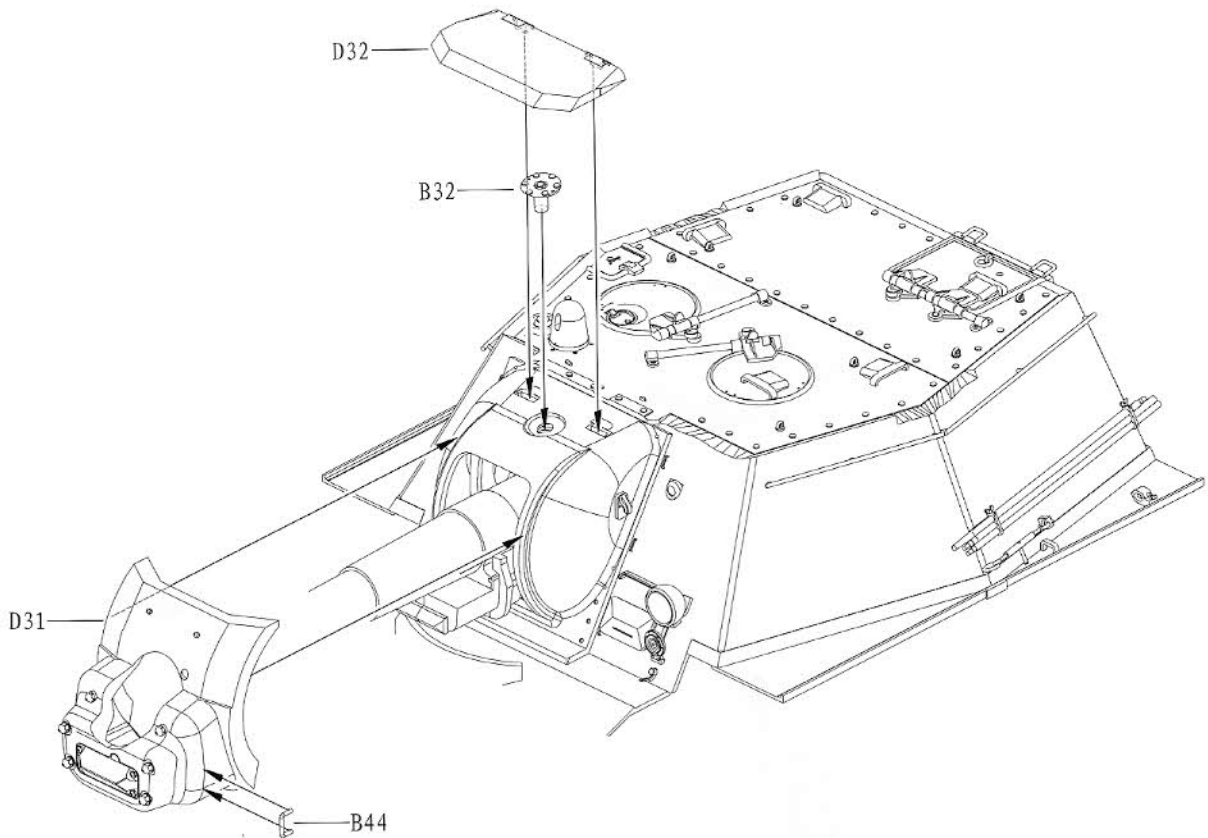

27

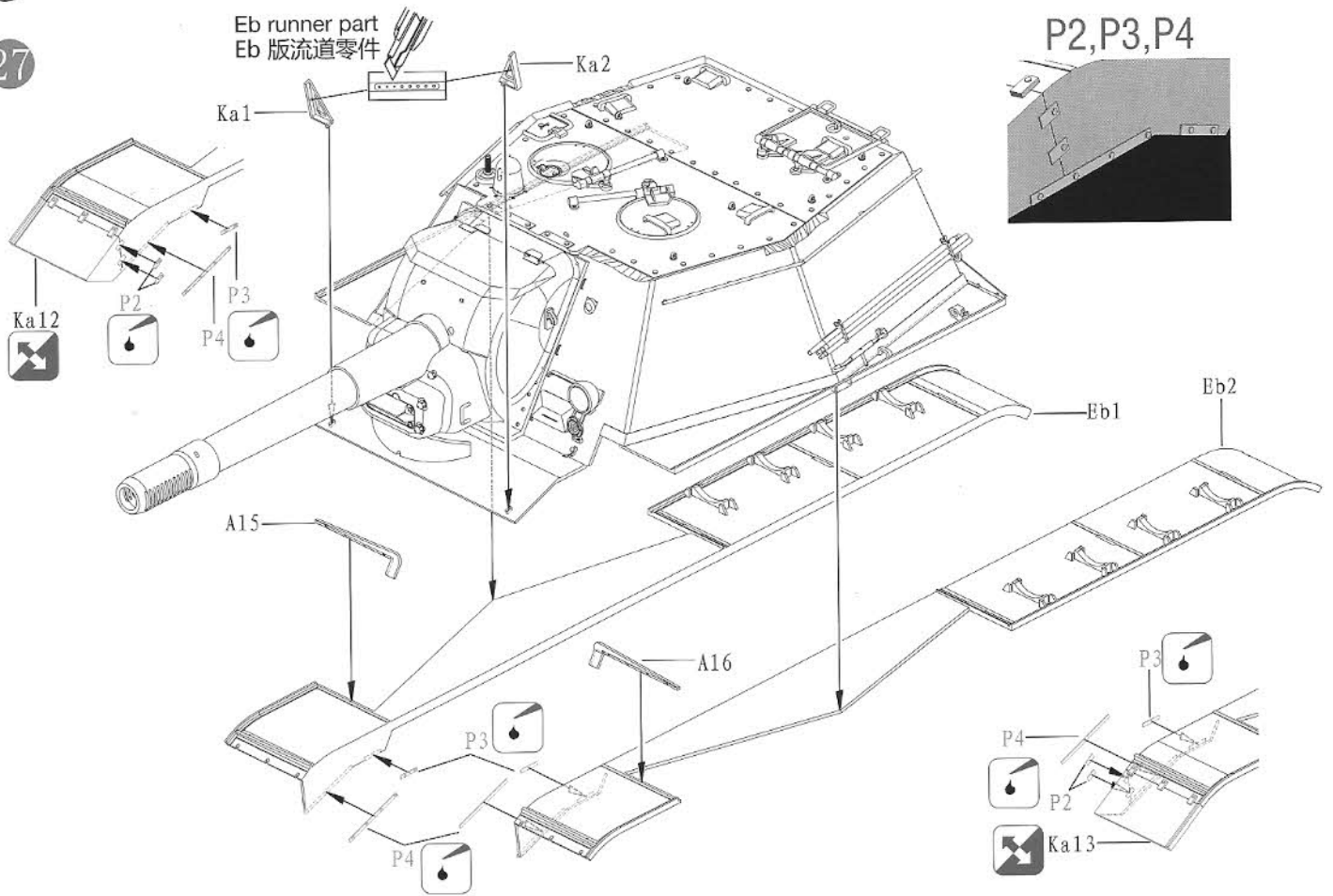

28

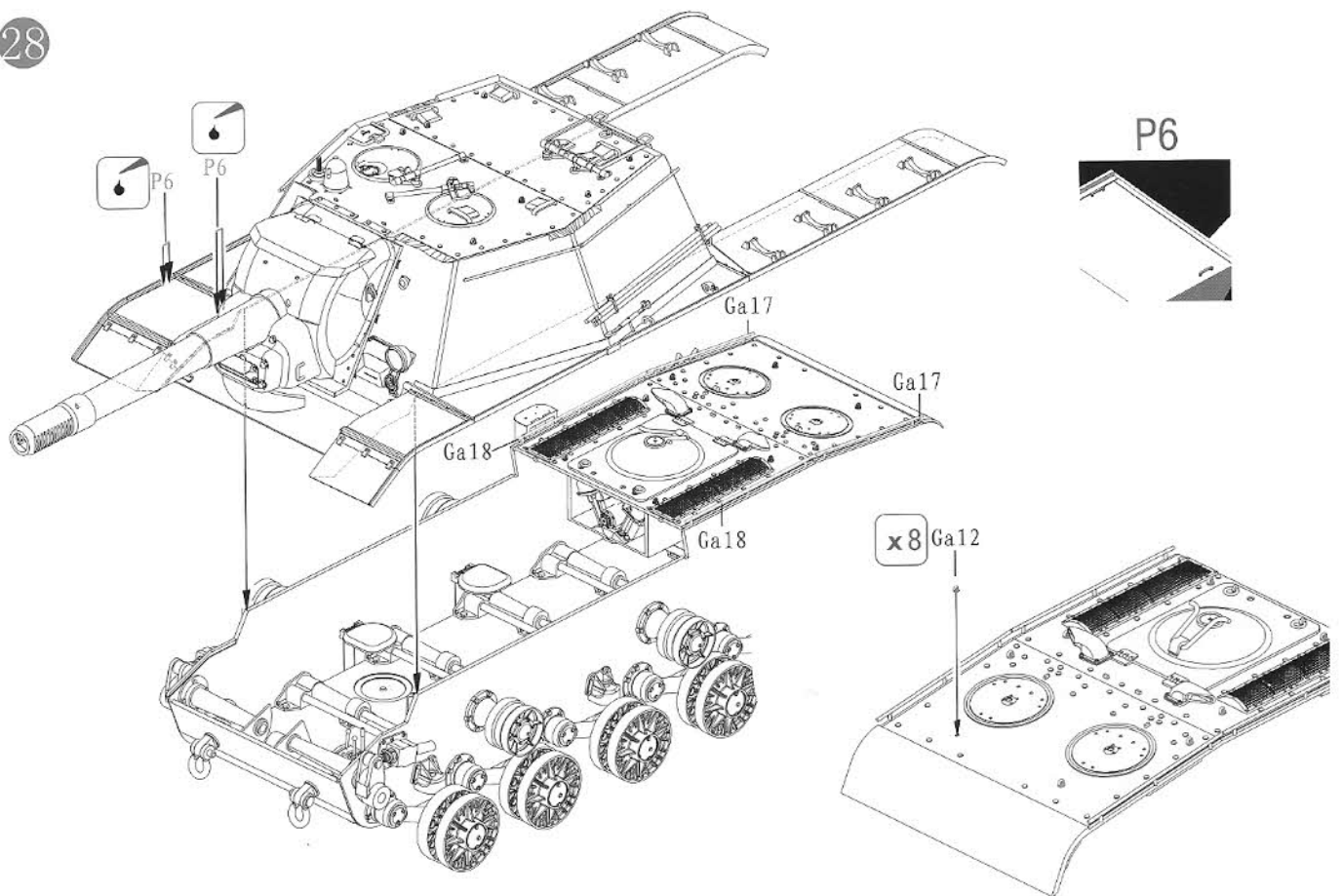

29

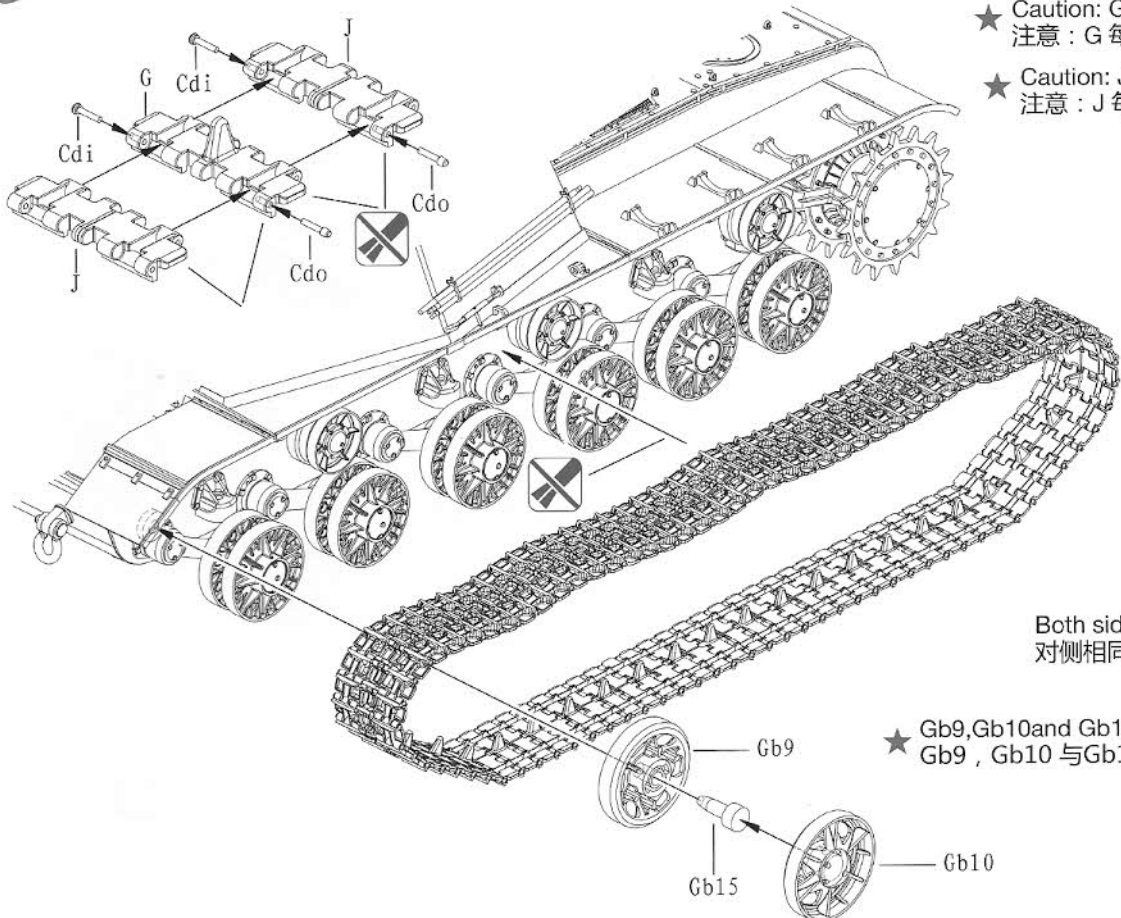

★ Caution: G Each set x44 pc
注意: G 每组需要44枚

★ Caution: J Each set x44 pc
注意: J 每组需要44枚

Both sides
对侧相同

★ Gb9,Gb10and Gb15 not cement
Gb9 , Gb10 与Gb15 不粘合

30

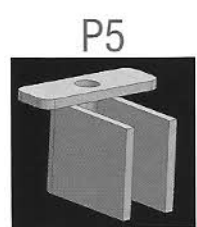
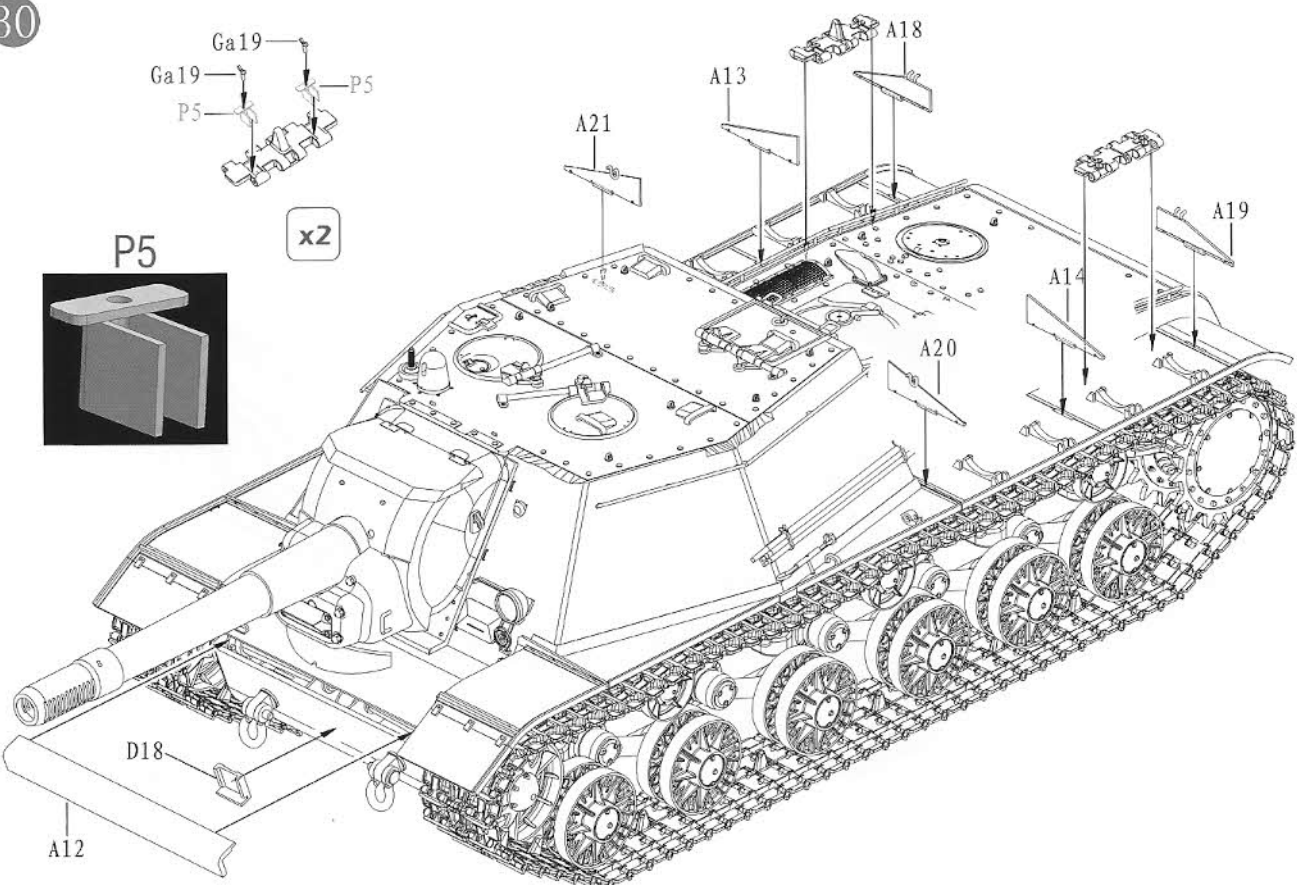

31

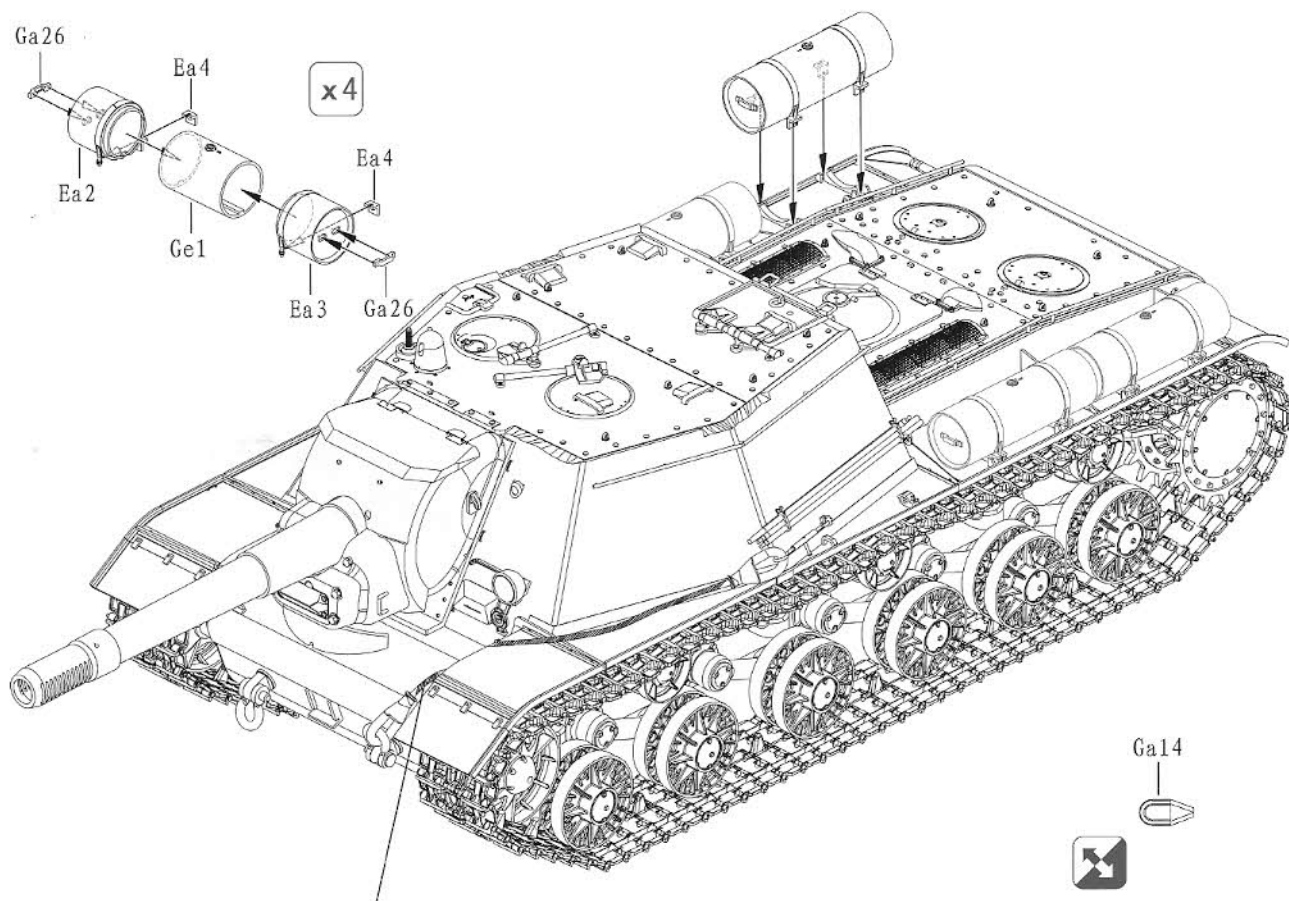

Copper wire
铜丝

32

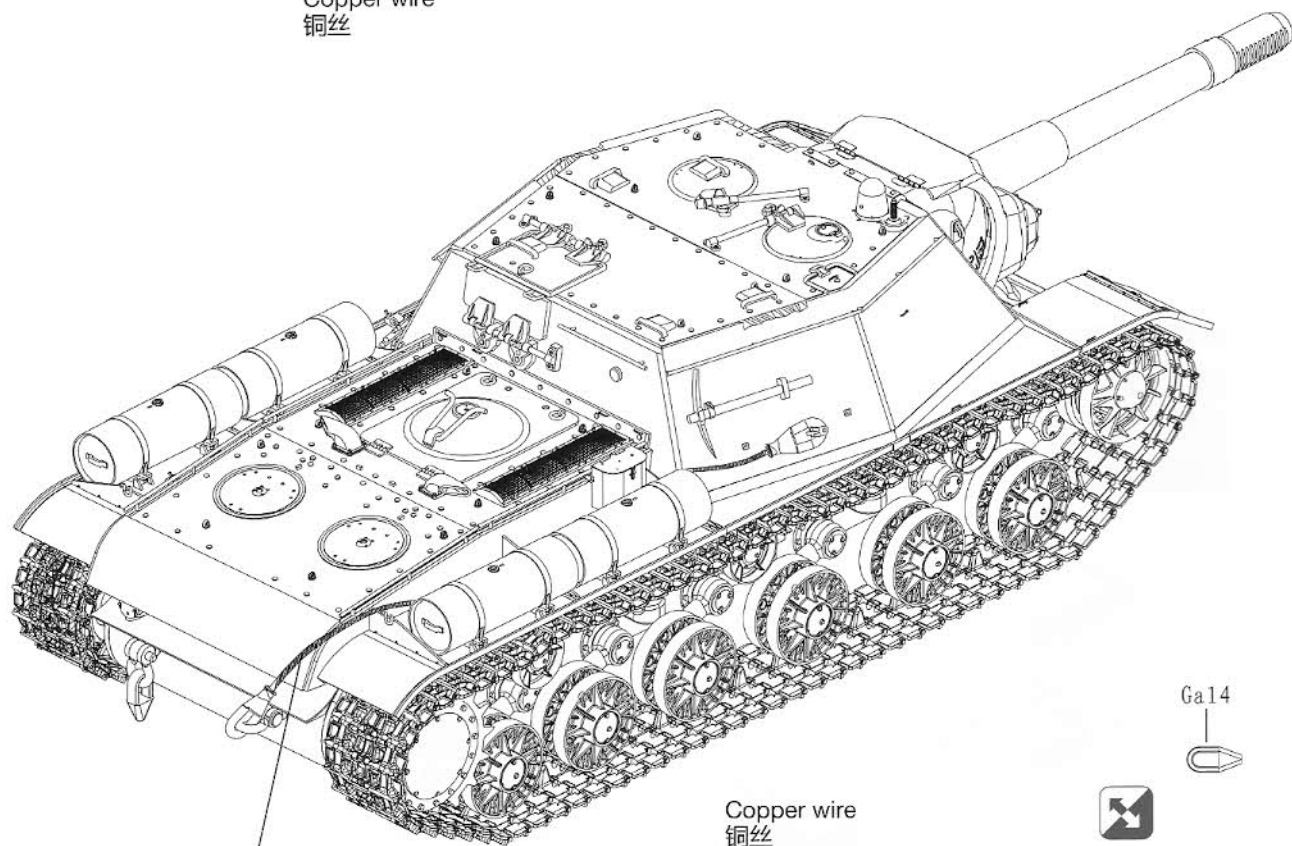

Copper wire
铜丝

Option 1: 1539th SP Artillery Regiment, Karlia, June 1944.
 1944年6月在东部战线作战之俄军第1539自走炮团之SU-152早期型。

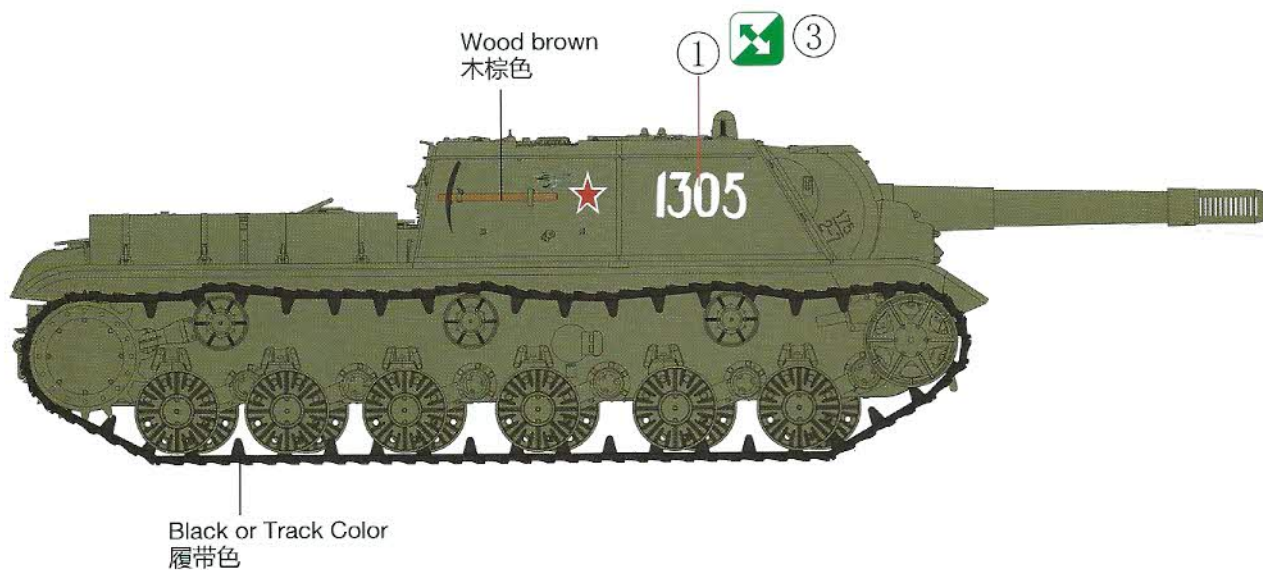
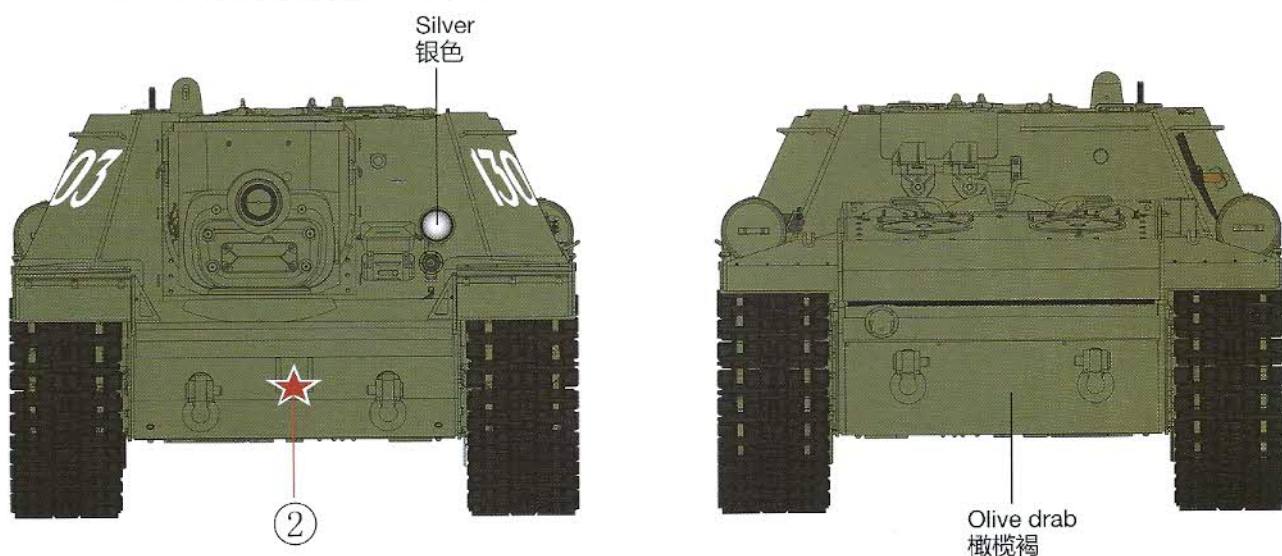

Option 2: Unit Unknown, Russian Front, Summer 1943.
1943年在俄国前战作战之SU-152前期型车辆(部队不明)。

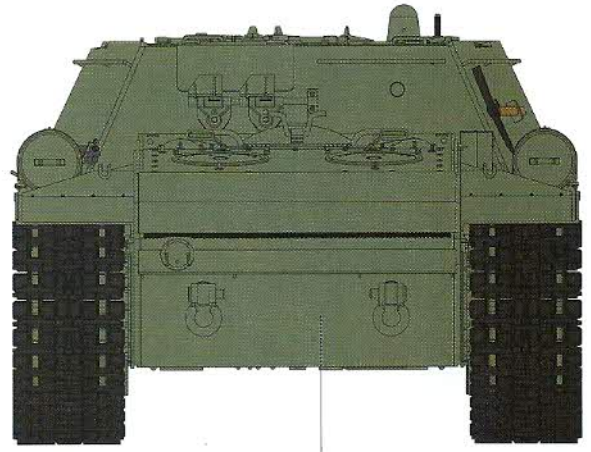
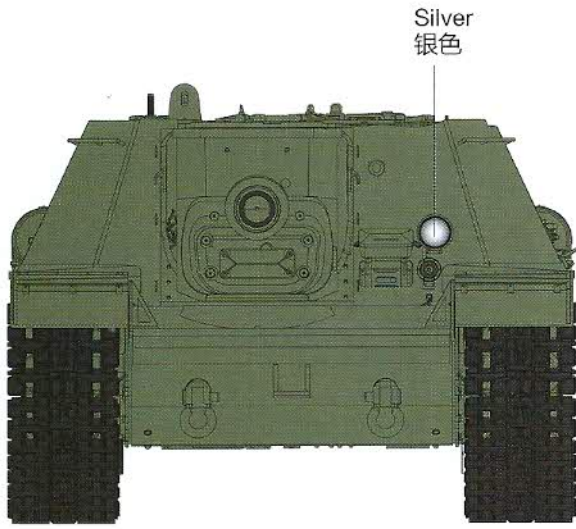

Olive drab
橄榄褐

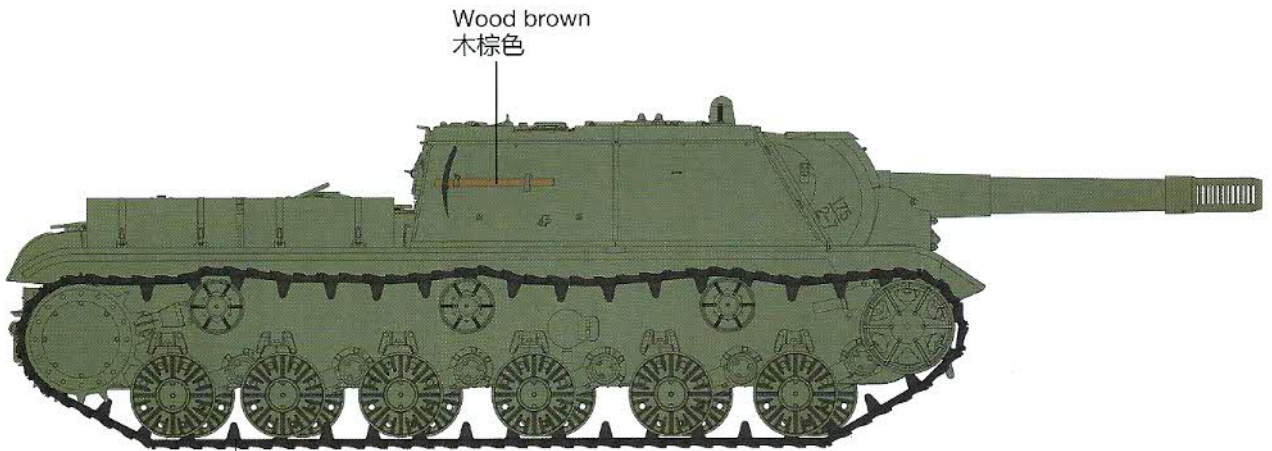

Wood brown
木棕色

Black or Track Color
履带色

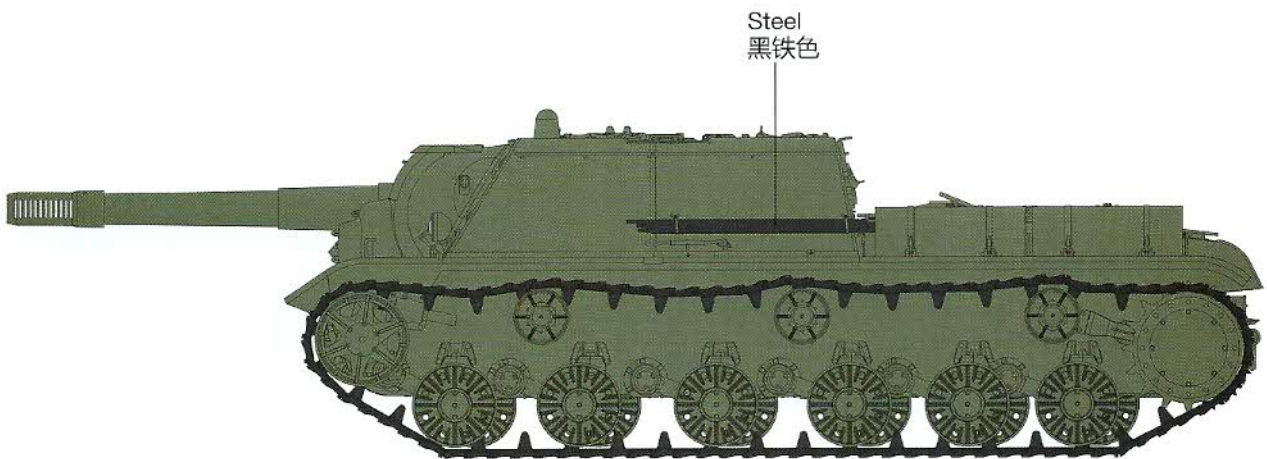

Steel
黑铁色

DECAL & COLOUR GUIDE 水贴及涂色指示:

Option 3: Unit Unknown, Eastern Front, Winter 1943.

1943年冬在东部战线作战之SU-152早期型车辆(部队不明)。

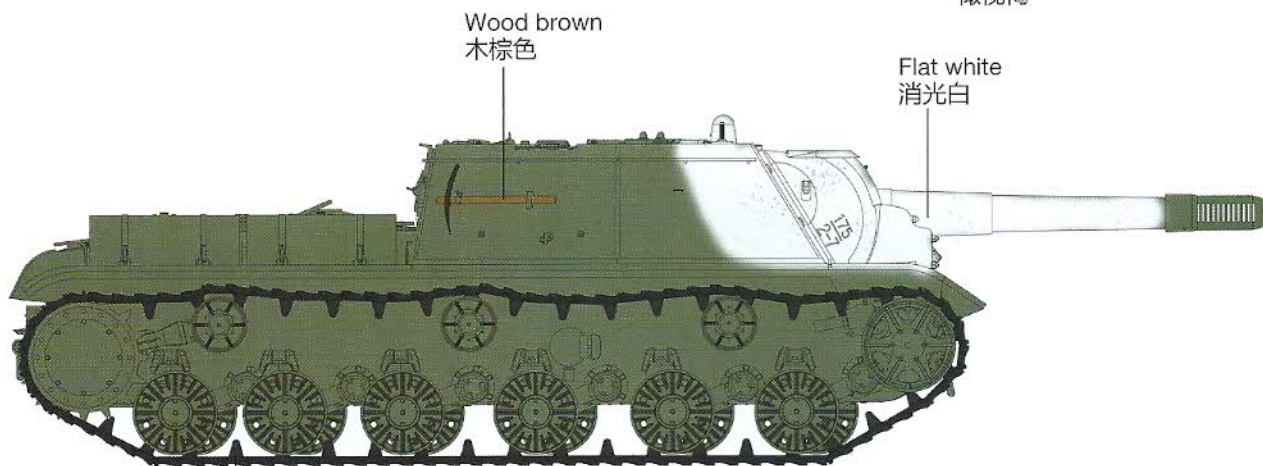
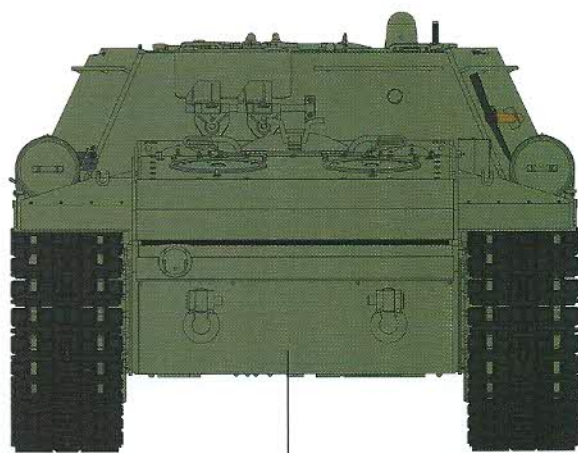
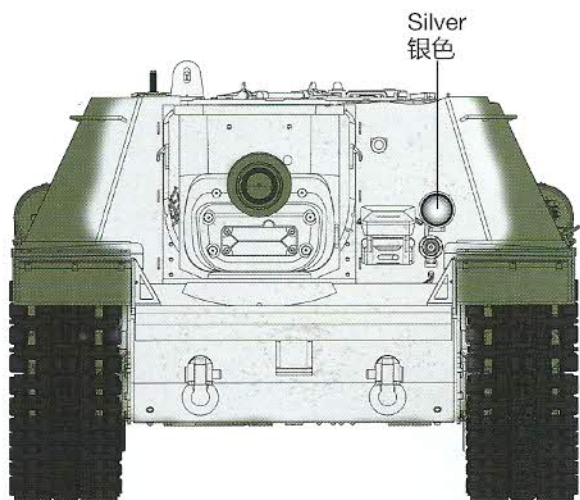

Black or Track Color
履带色

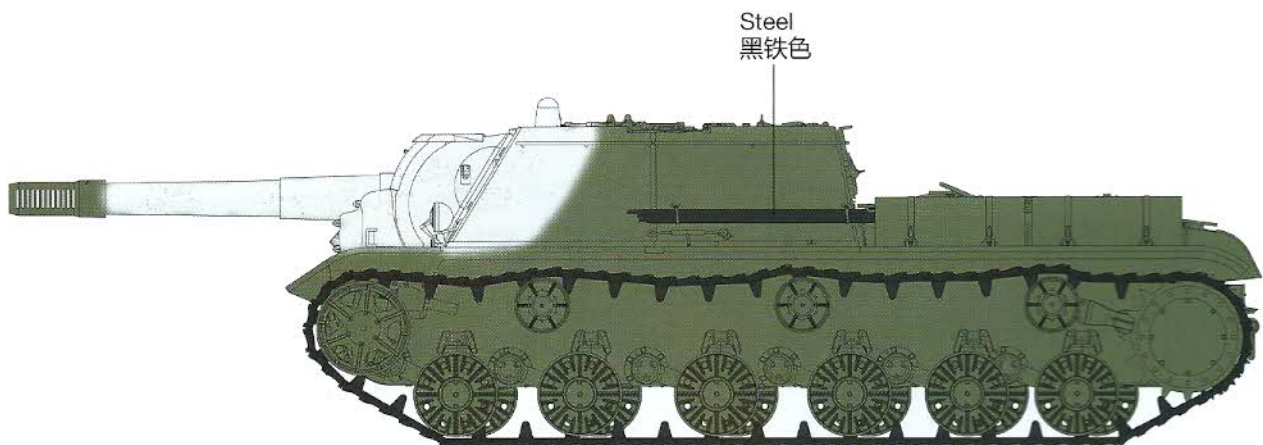

Option 4: Unit Unknown, Eastern Front, Winter 1943.

1943年冬在东部战线作战之SU-152早期型车辆(部队不明)。

Silver
银色

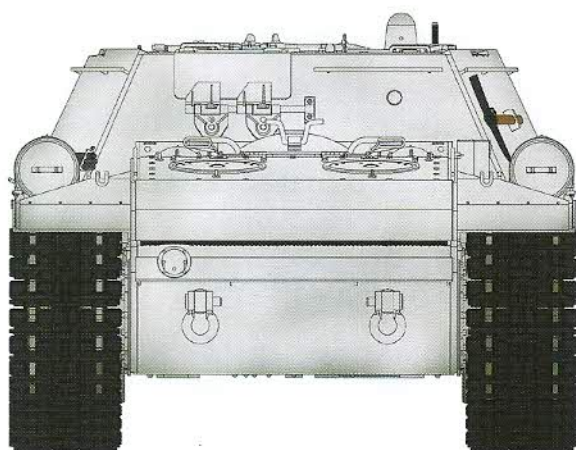
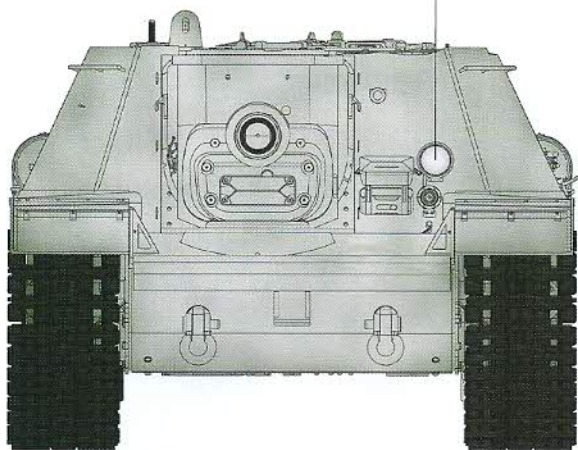

Wood brown
木棕色

Flat white
消光白

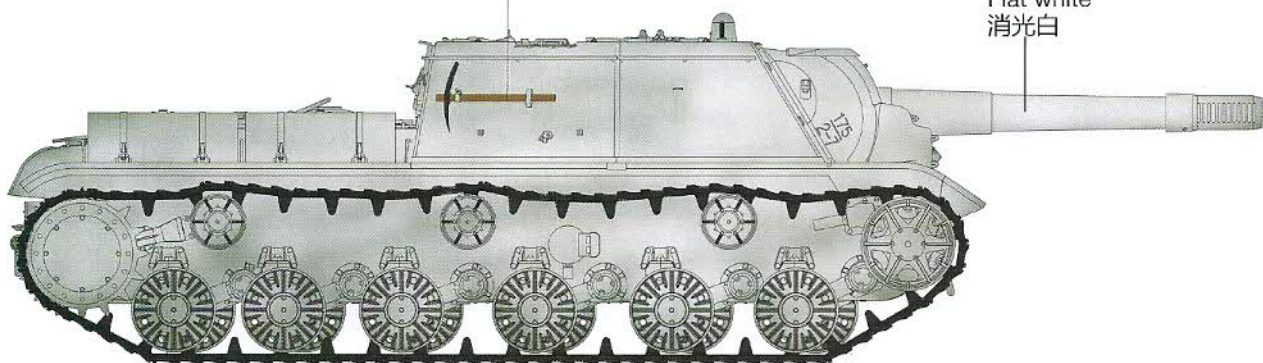

Black or Track Color
履带色

Steel
黑铁色

