

**NIKO**  
MODEL

FOR

**IBG**  
MODELS**INSTRUKCJA MONTAŻU**  
**ASSEMBLY INSTRUCTION**

kit N° IN-09 1:35

for

**IBG 3510 Büssing-NAG 500 S****IBG 3511 Büssing-NAG 500 A****IBG 3512 Büssing-NAG 4500 S****IBG 3513 Büssing-NAG 4500 A****PL****WAŻNE**

-Elementy żywiczne i fototrawione należy kleić klejem cyjanoakrylowym.  
Prace wykonywać w miejscu dobrze wentylowanym. Po skończonej pracy umyć ręce.

-W celu łatwiejszej obróbki elementów żywicznych, należy je wcześniej zanurzyć na kilka chwil we wrzącej wodzie. Żywica stanie się plastyczna, co znacznie ułatwi pracę.

-Ewentualne odkształcone części można przywrócić do właściwej postaci poprzez zanurzenie na ok. 15-30 sekund we wrzącej wodzie i po wyjęciu właściwe uformowanie.

**UK****IMPORTANT**

-Resin and Photo-Etched parts can only be glued with cyanoacrylate glue.  
You should work in a well ventilated area. After work, remember to wash your hands.

-To make resin parts easier to work with, first put them into boiling water for a few seconds. The resin becomes softer.

-Parts that have become warped can be restored to their correct form by dipping into boiling water for 15-30 sec. and shaping them appropriately afterwards.

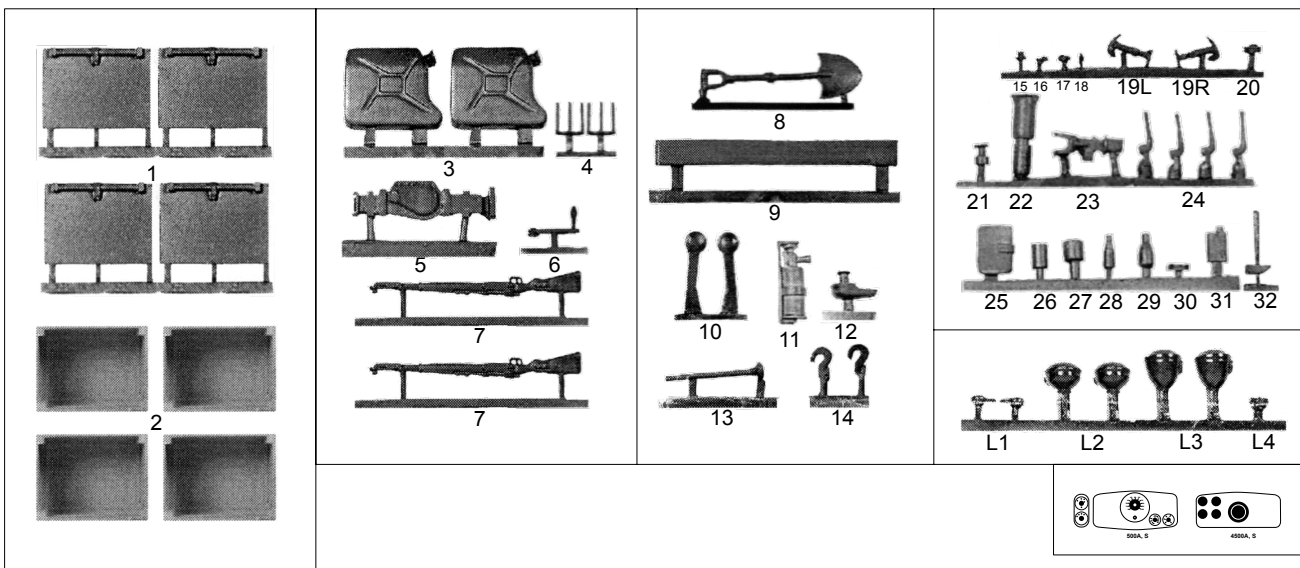
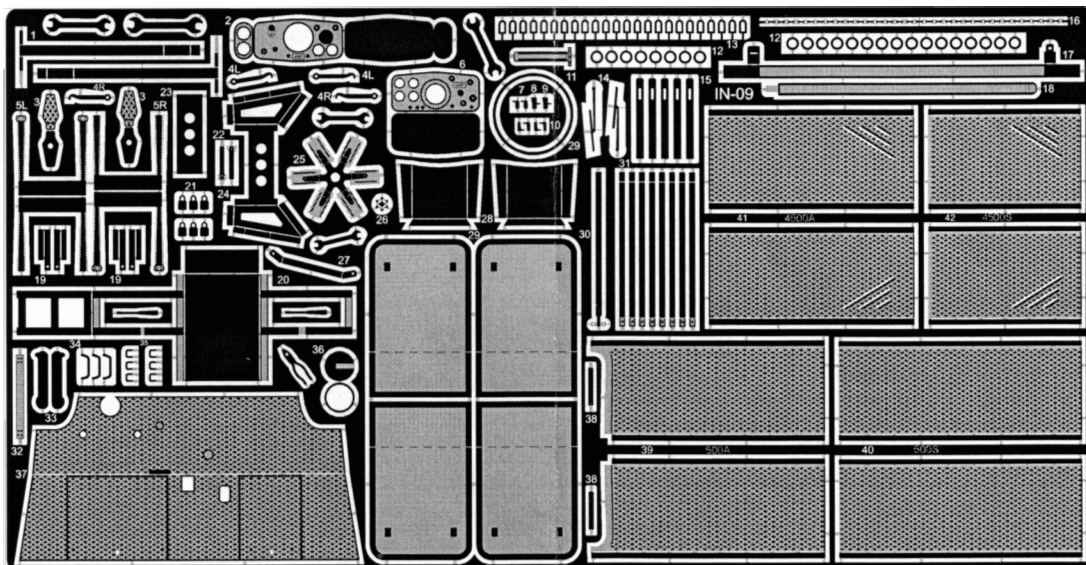
 **RESIN PARTS** **PHOTOETCHED PARTS**

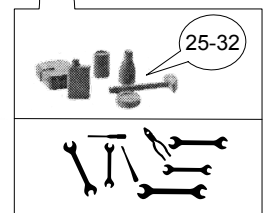
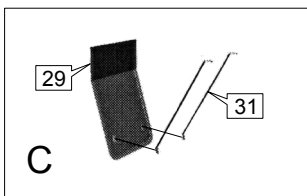
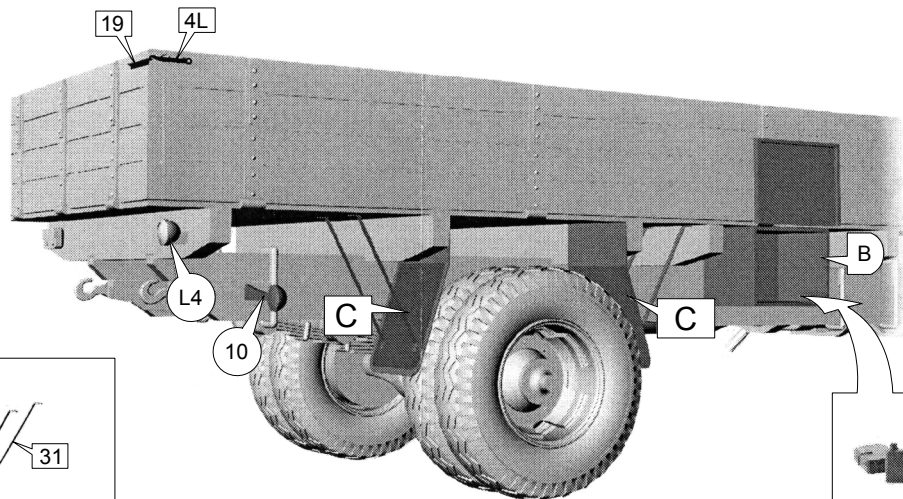
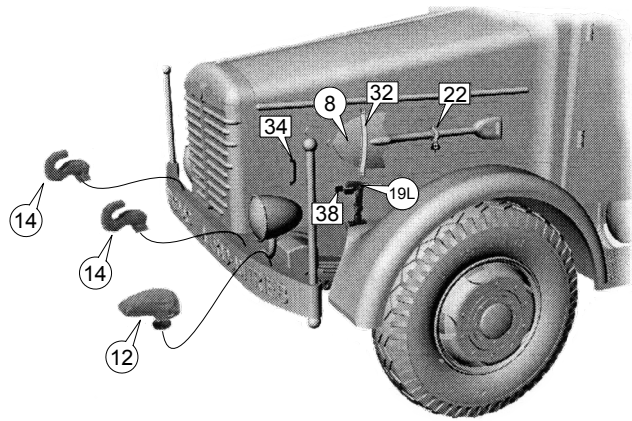
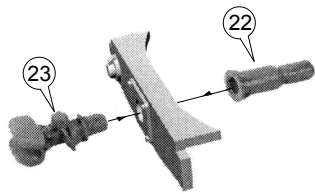
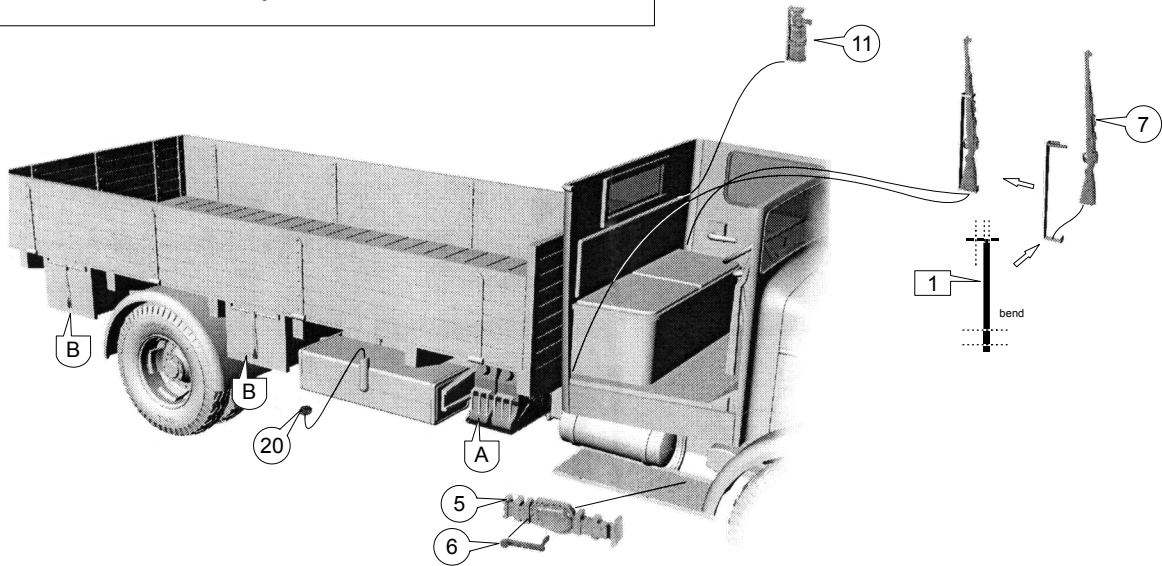
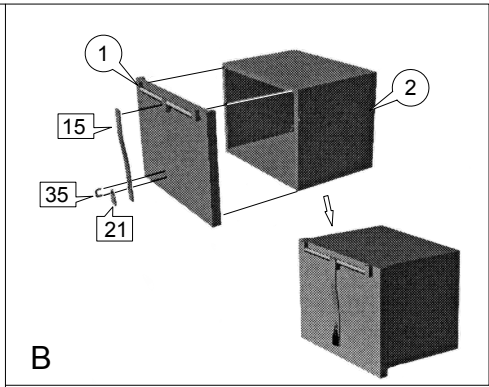
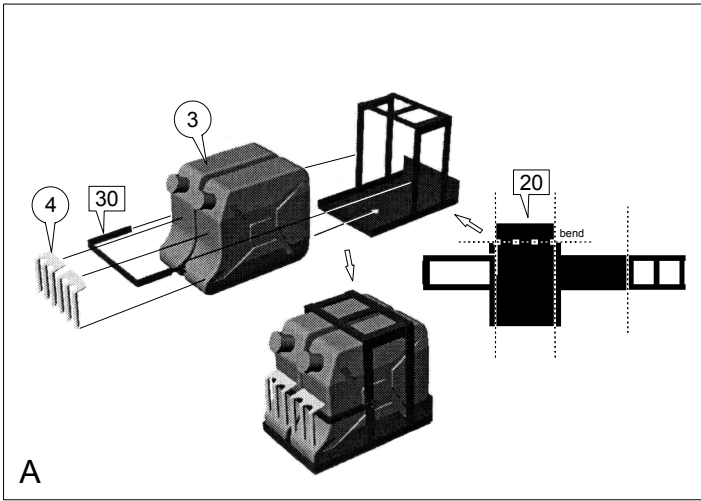

4500A,S

