

ACADEMY**HOBBY MODEL KITS****1/48TH SCALE**

SUKHOI SU-27 FLANKER B

When the SU-27 performed its "Cobra", maneuver at the 1989 Paris Air Show, the western world suddenly learned that the SU-27 design was very probably the finest fighter plane in the world. To see this very large airplane fly at an attack angle of 120 degrees without crashing, shocked every observer. Since then the routine has been performed as a demonstration feature at most air shows.

From 1977, when the prototype T-10 was spotted by satellite, until 1988, few hard facts and little information were available. It was thought that this twin-engined fighter plane had strong design resemblances to parts of the F-14, F-15 and F-18.

Between October 1986 and December 1988 a specially modified prototype T-10, known as the P-42 was used to establish 27 performance records which were submitted to the FIA for certification. All the records previously established by the F-15 Strike Eagle were wiped out by the P-42. When this information was published, it became general knowledge that this was an aircraft to be considered most seriously.

Some analyst think that the Russian avionics and weapons systems are not quite equal to the western competition, but in terms of speed, range and maneuverability, the SU-27 is superior to any aircraft in the western inventory. Probably until such time that the Lockheed F-22 is operational, the SU-27 must be regarded as the best fighter in the world.

Much of the SU-27's performance must be credited to its superb AL-31F engines which are rated at 12,500Kg(27,550lb) thrust in after-burner stage. The engines which are easy to maintain and interchangeable between left and right, have a tremendous tolerance to severely disturbed air flow. It is this feature that allows the engines to run smoothly while the Flanker performs these unusual maneuvers. Unlike earlier short-lived Soviet jet engines, the AL-31F engines have a life of 3,000 hours based on 100 hour engine checks and 1,000 hour overhauls. This is fully comparable to the best the west can offer.

Armed with four R-73 AA-73 Archer missiles for short range combat and an array of R-27 IR-homing long range missiles, the SU-27 also carries the same internal GSh-30-1 30mm cannon used by the MIG-29, Firing at a rate of 1,500 rounds per minute, the cannon barrels only have a life expectancy of 80 seconds before they must be replaced.

The SU-27 Flanker B, together with the MIG-29 give Russia air combat capability that is certainly equal to but most likely superior to that presently available to the west.

2131

Cement Parts
Coller
Kleben
Pegar
Incollare
Cola
Kleven



DO NOT cement
Ne pas coller
Nicht kleben
No pegar
Non incollare
Nao colar
Niet kleven



Cut away
Couper
Scheiden
Cortar
Tagliare
Cortar
Snijden



Optional parts
Choix
Auswahlmöglichkeit
Eleccion
Scelta
Opcao
Keuze

**3**

Repeat operation
Répéter l'opération
Vorgang wiederholen
Repitir la operacion
Ripetere
Repitir a operacao
Herhalen

1 LOWER FUSELAGE HALF PREPARATION



Open holes if installing pylons.

Open holes if installing pylons.

Open holes if installing pylons.

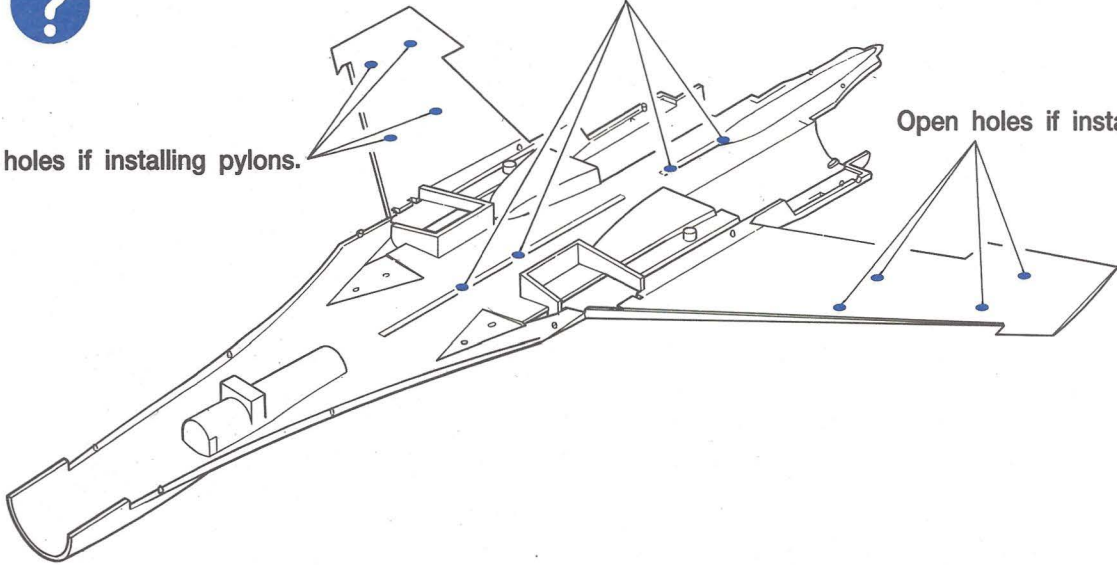

2 FAN BLADE INSTALLATION

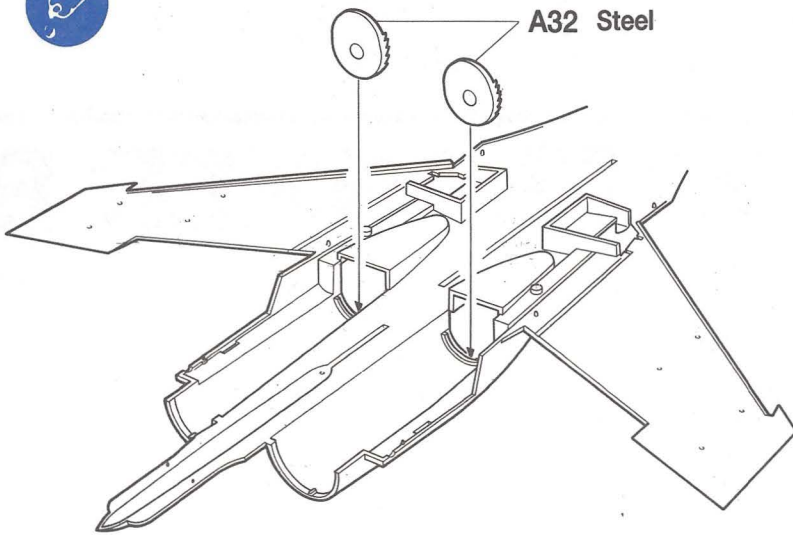

3 UPPER FUSELAGE HALF PREPARATION

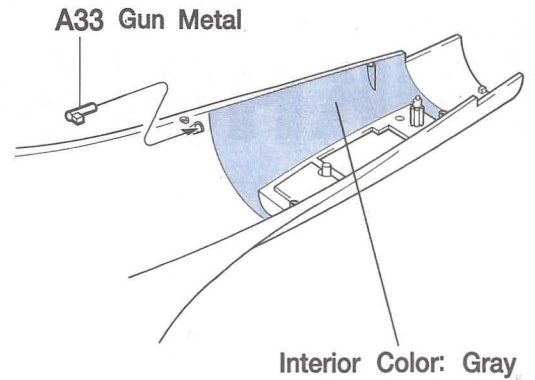

4 COCKPIT ASSEMBLY

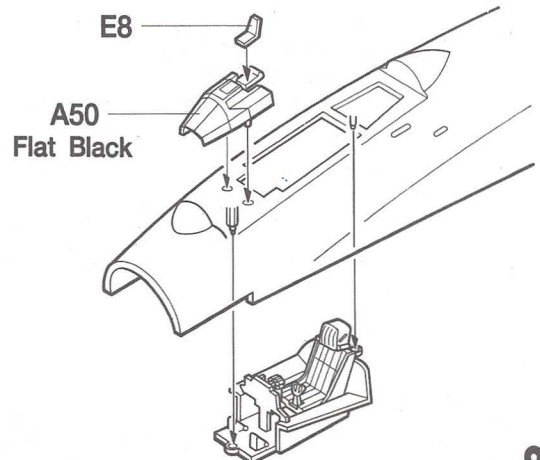
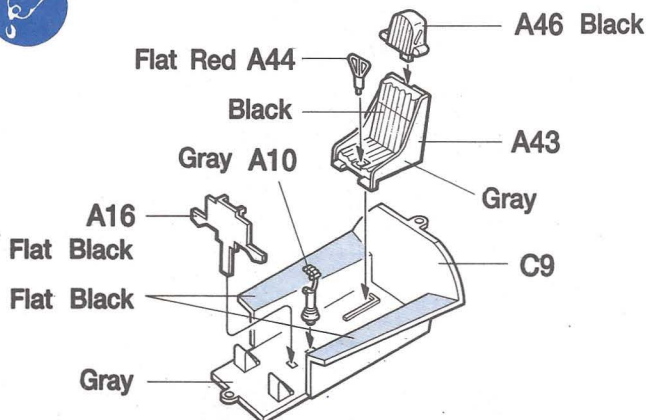

5 FUSELAGE HALVES ASSEMBLY

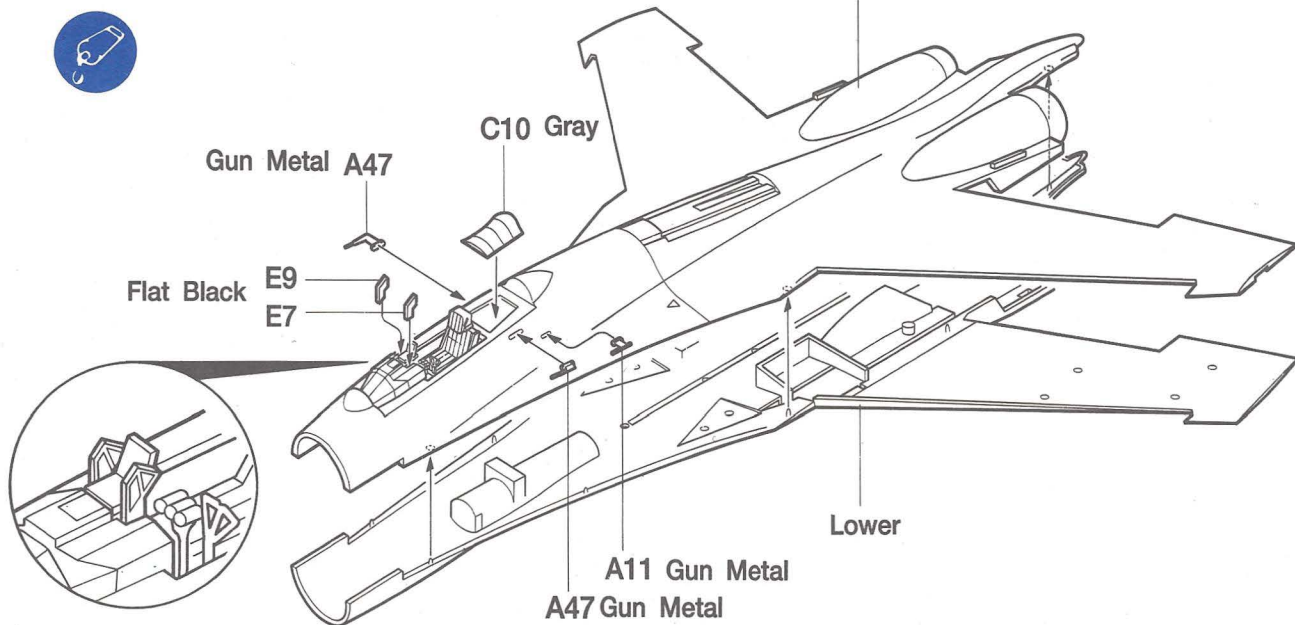

6 AIR INTAKE ASSEMBLY

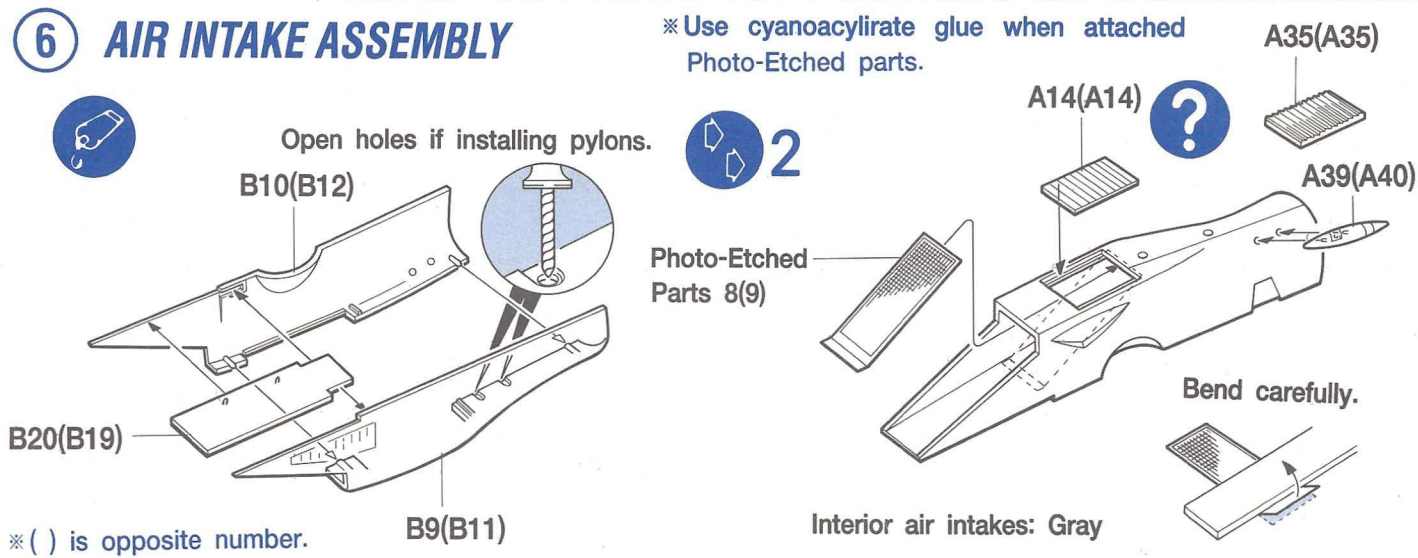

7 LOWER FUSELAGE COMPONENTS INSTALLATION

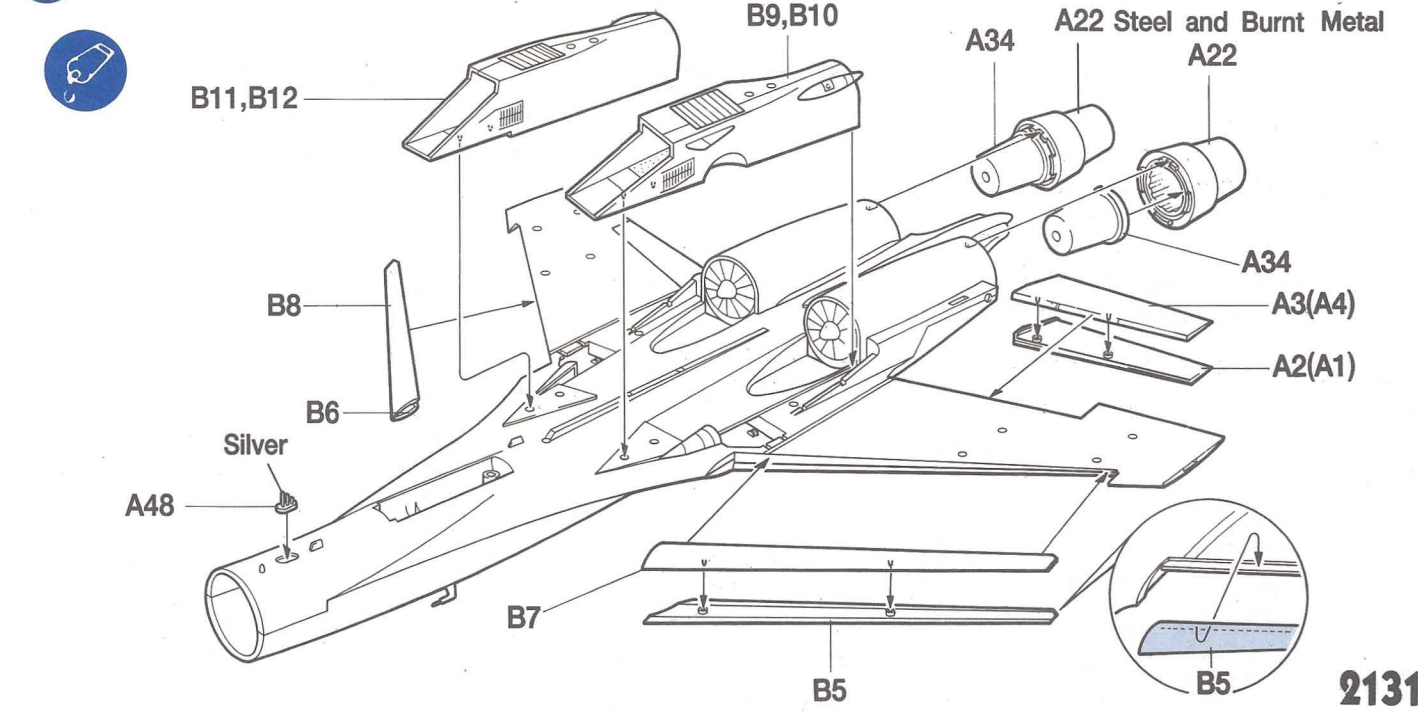

8 LANDING GEAR ASSEMBLY

Wheel hubs: Dark Green

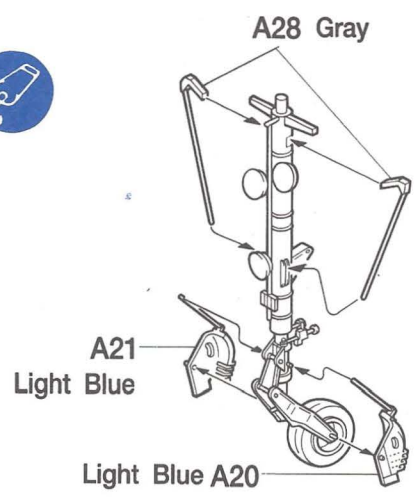
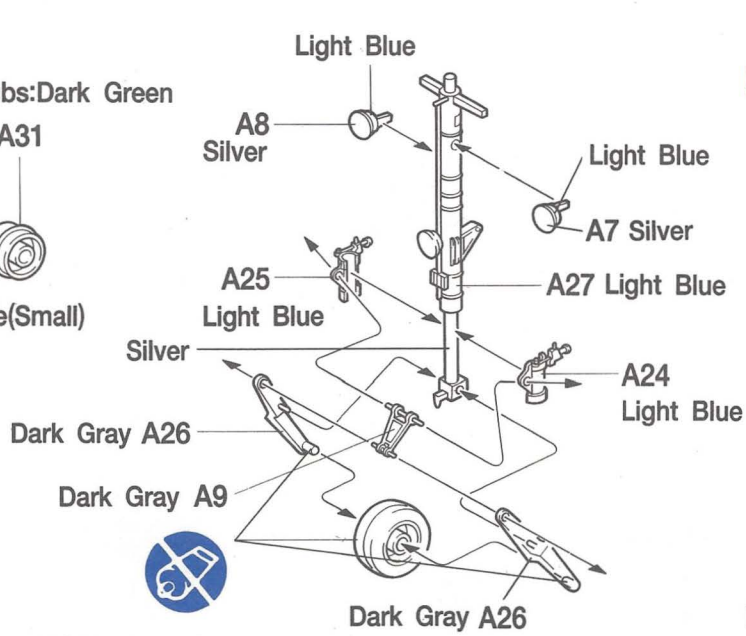
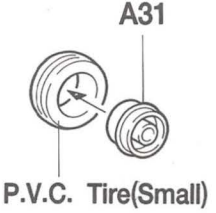

Remove the useless portions.

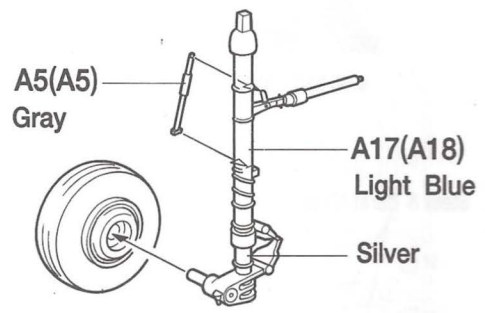
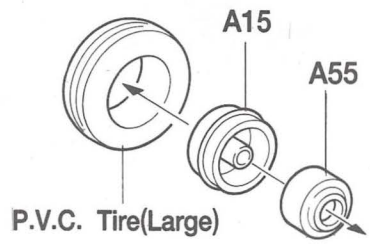
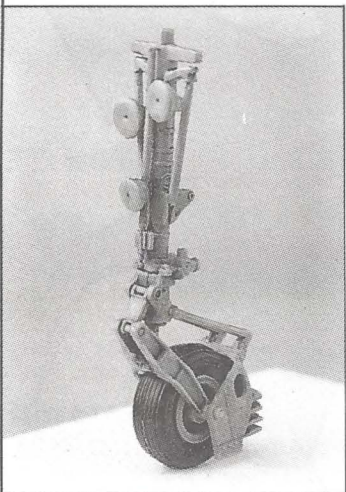
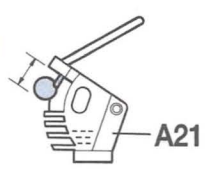

9 LANDING GEAR, DOOR AND FIN INSTALLATION

Interior landing gear wells: Gray

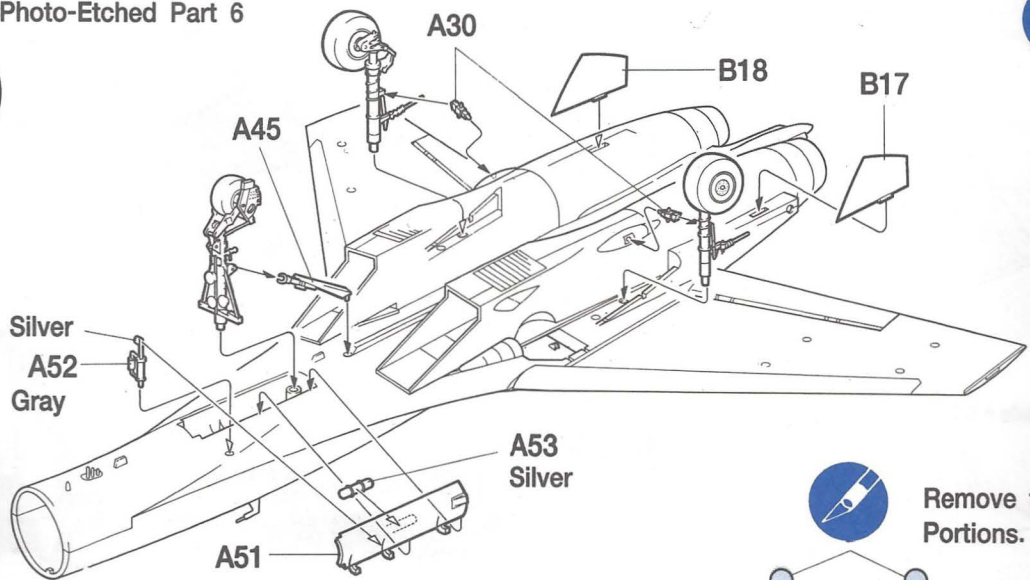
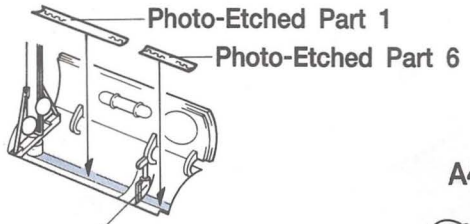

Remove the useless Portions.

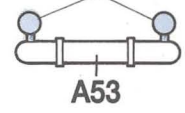

10 NOSE AND LANDING GEAR DOOR INSTALLATION

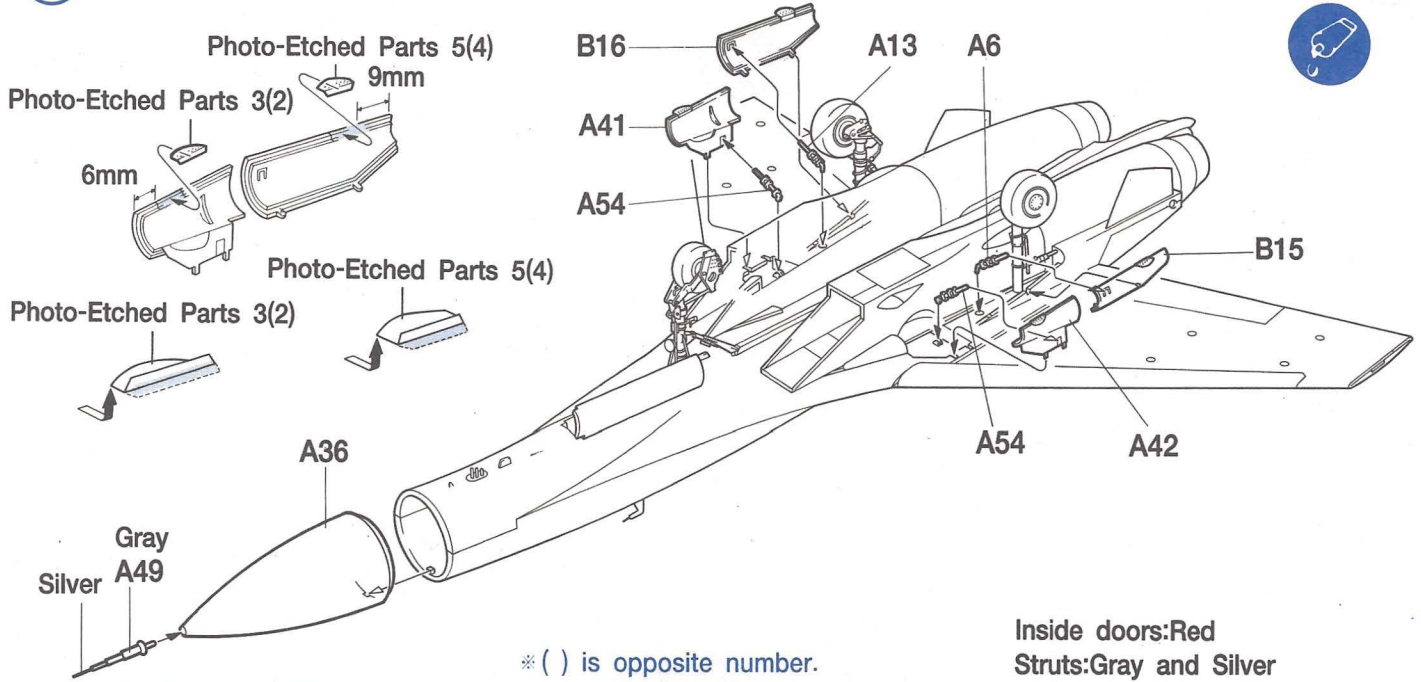

11 WEAPONS AND PYLONS ASSEMBLY

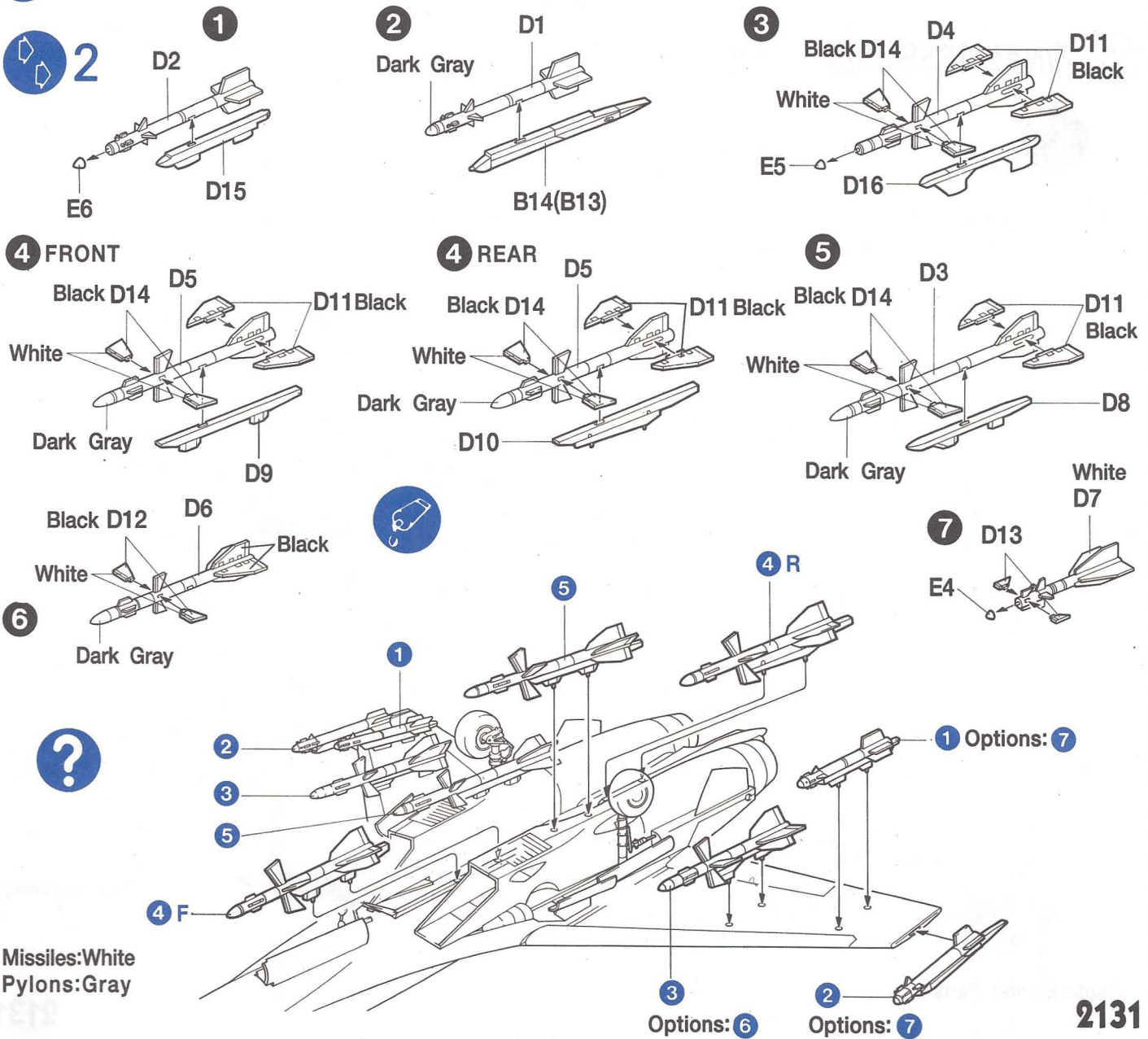

12 RUDDER AND ELEVATOR ASSEMBLY

LEFT

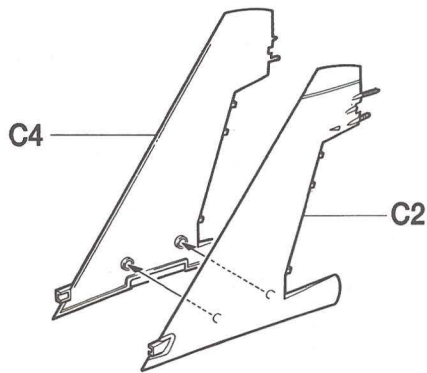

RIGHT

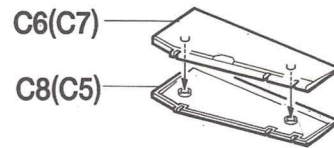
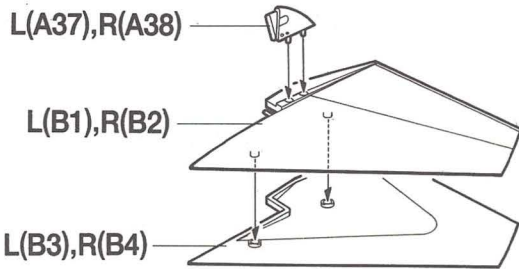
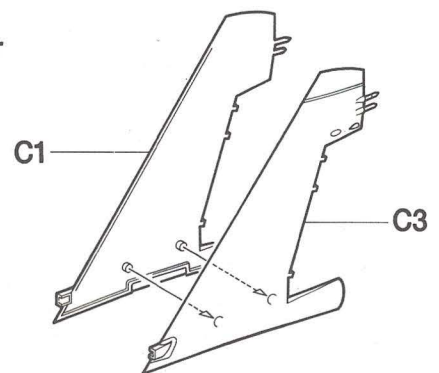

13 FINAL ASSEMBLY



Inside air brake:
Yellow Green

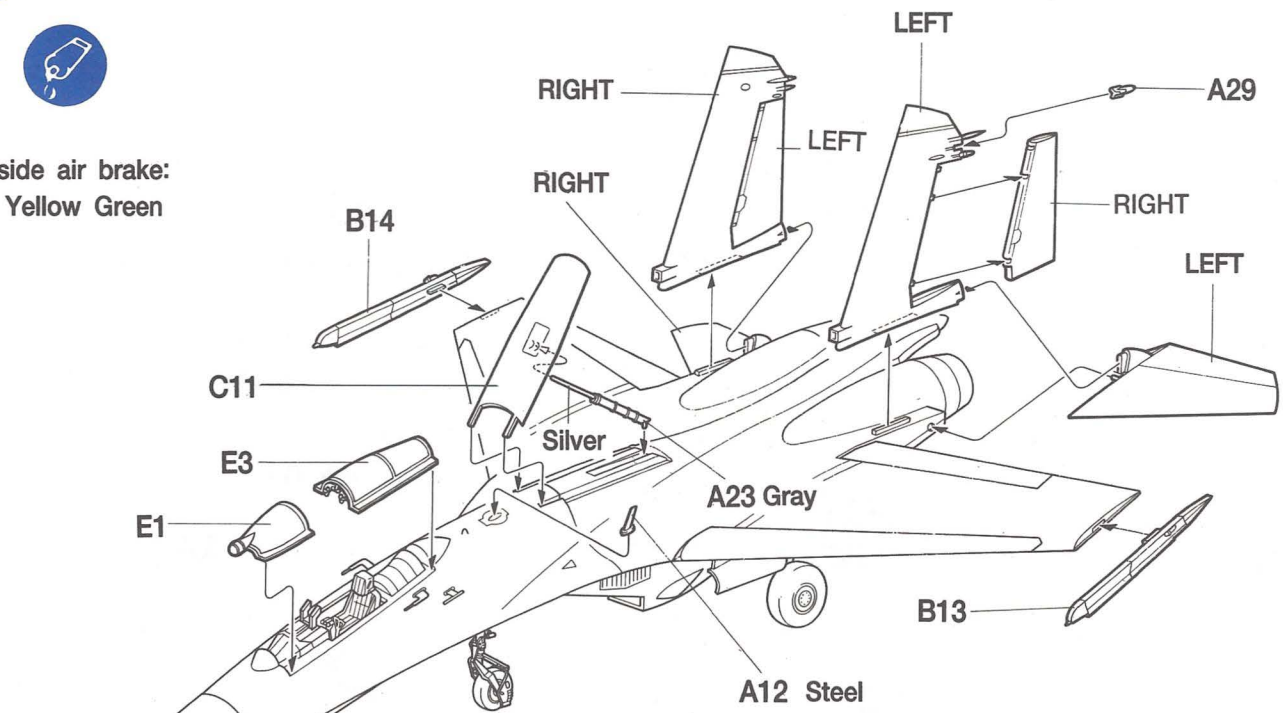
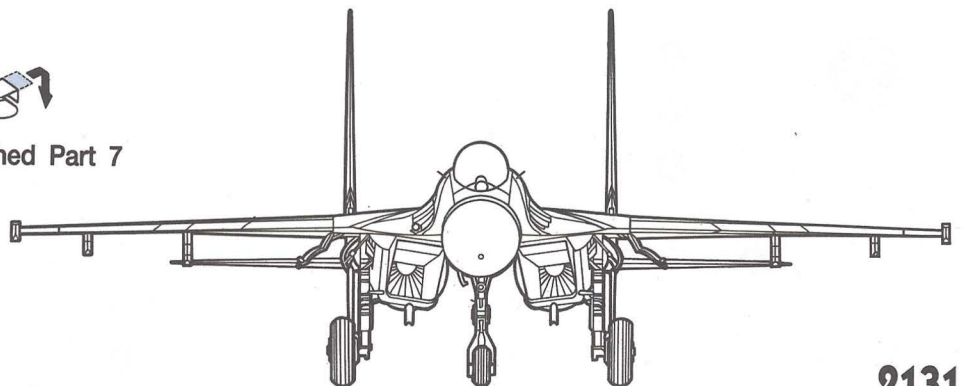

Photo-Etched Part 7

Photo-Etched Parts 7



PAINING AND DECAL PLACEMENT



WHITE F.S.17778



STEEL



DARK GREEN F.S.34138



DARK BLUE F.S.25450
NICHE NO. 7706



BLUE GRAY F.S.25526
NICHE NO. 7707



LIGHT BLUE F.S.25550
NICHE NO.7708

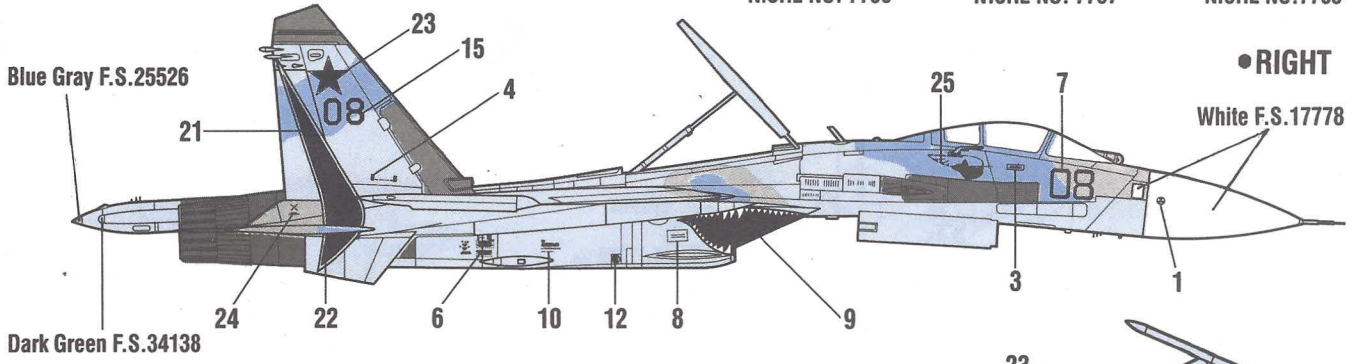

•TOP

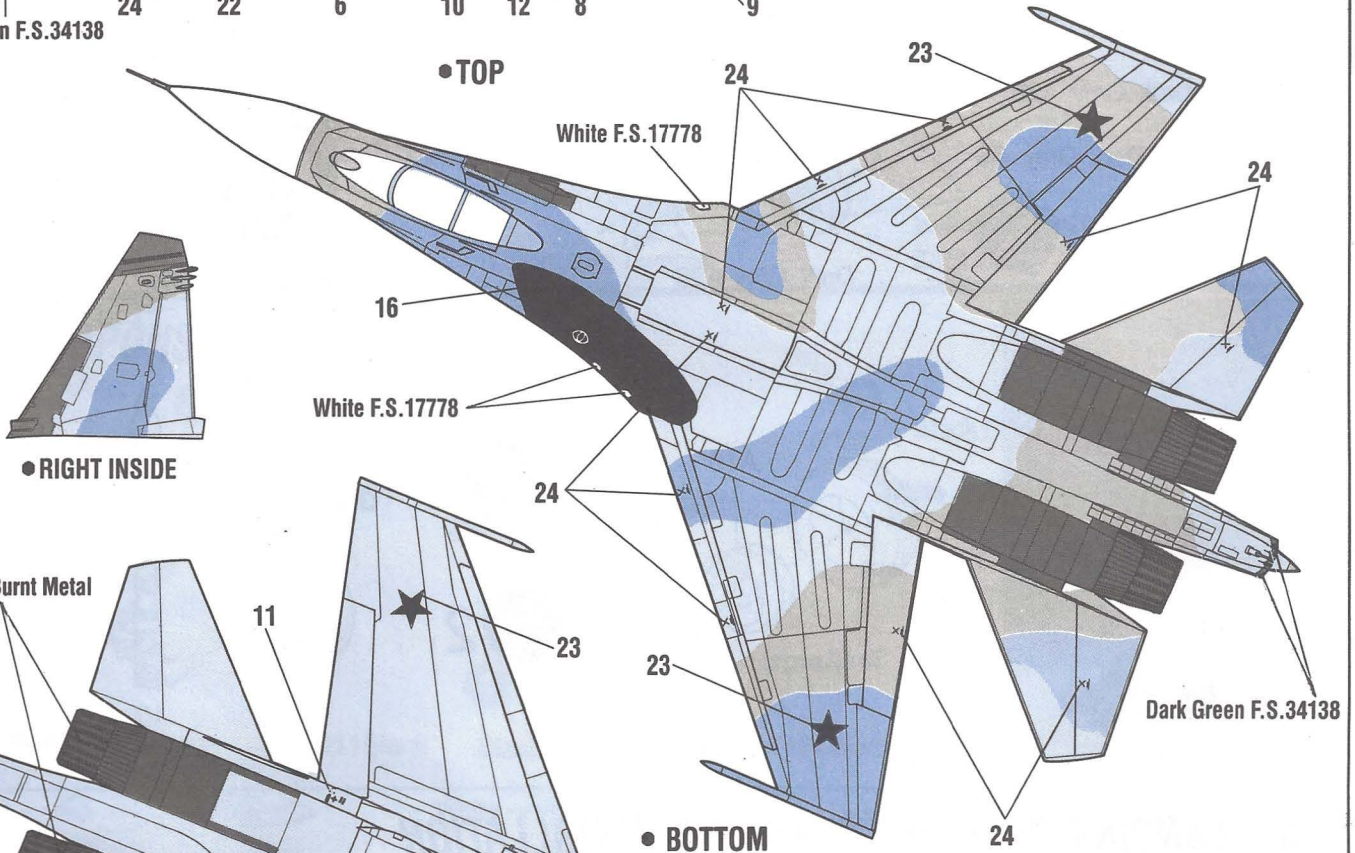

•RIGHT INSIDE

•BOTTOM

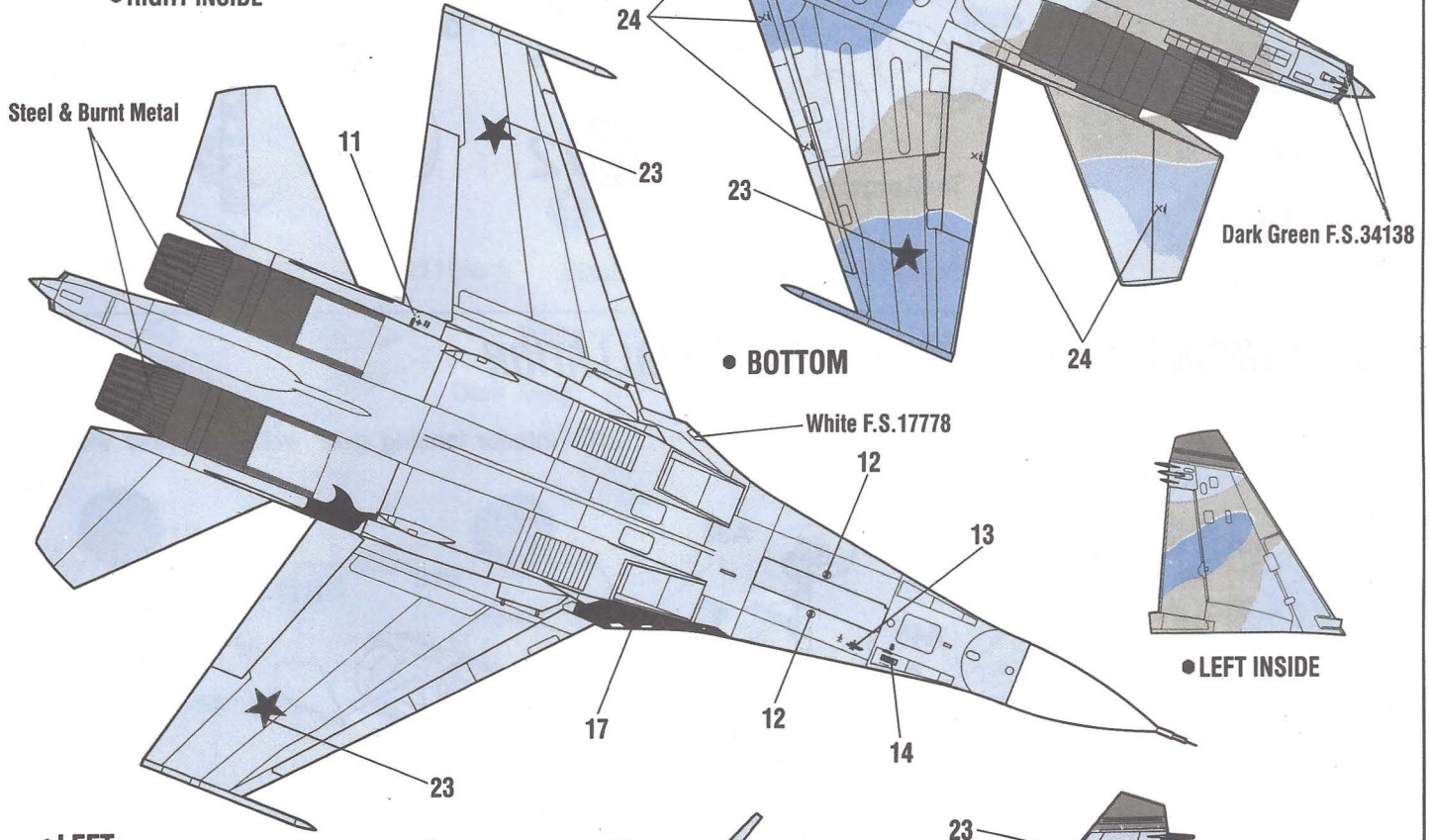

•LEFT INSIDE

•LEFT

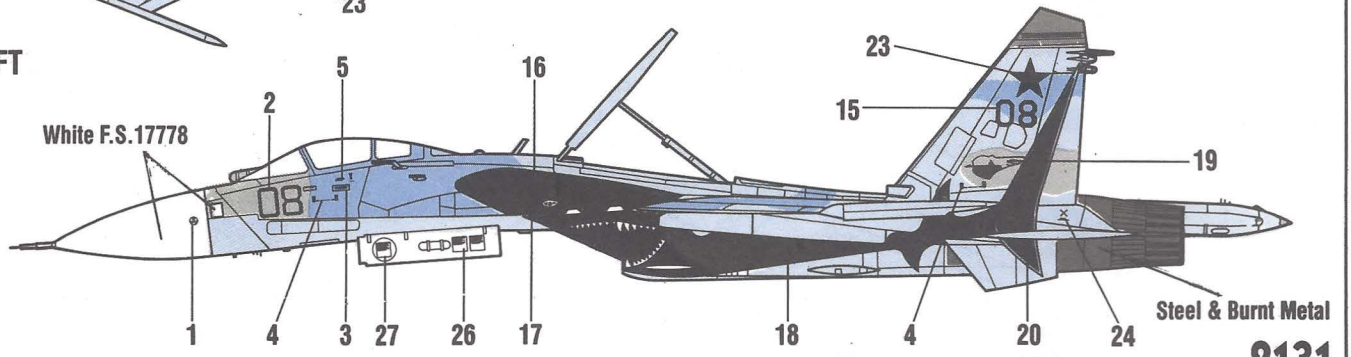

*Do not use No.10, 12.

2131

PARTS LOCATING DIAGRAM

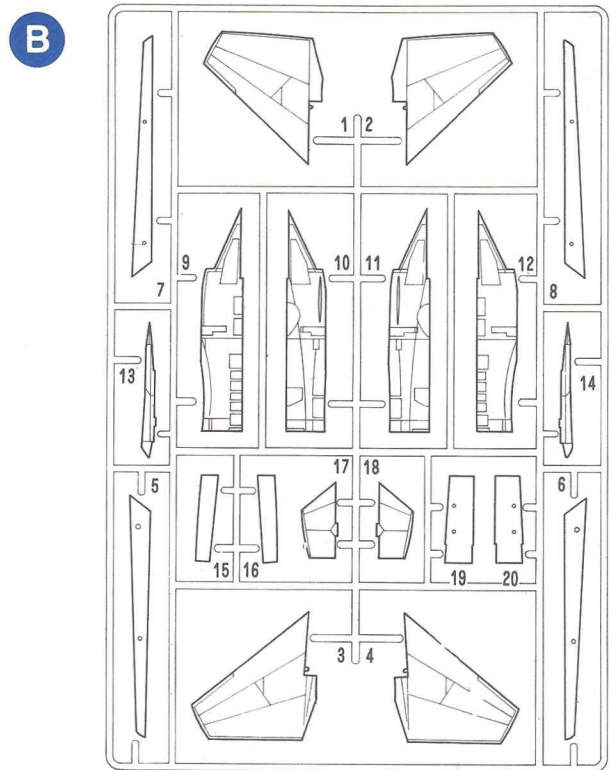

● Unused Parts: A19, E10, Photo-Etched Parts 7×2

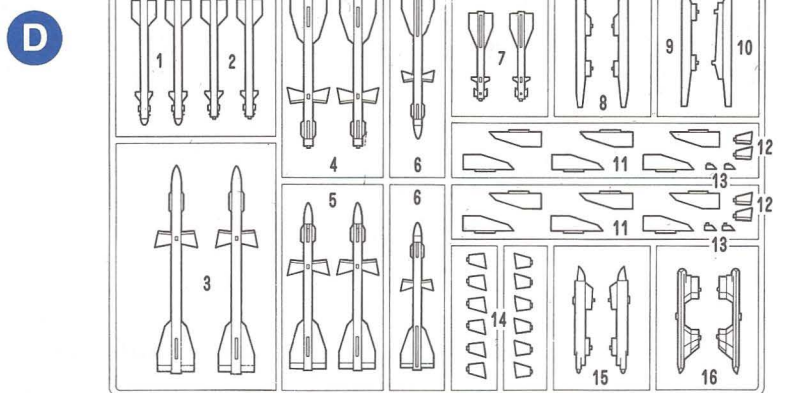
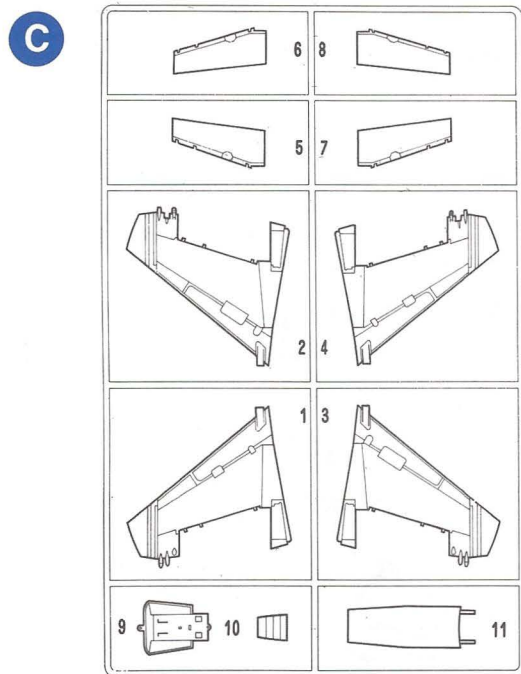

- P.V.C. Tires(Large)×2, Tire(Small)×1
- Fuselage Upper×1, Lower×1

● Photo-Etched Parts

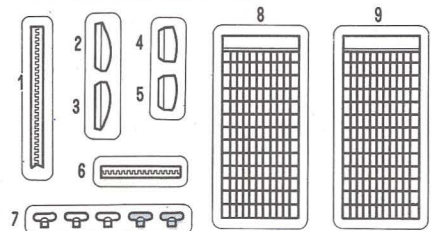

ENGLISH	FRENCH	GERMAN	SPANISH	ITALIAN
WHITE	BLANCO	WEISS	BLANC	BIANCO
YELLOW	JAUNE	GELB	AMARILLO	GIALLO
RED	ROUGE	ROT	ROJO	ROSSO
BLUE	BLEU	BLAU	AZUL	BLU
GRAY	GRIS	GRAU	GRIS	GRIGIO
GUNMETAL	METALLIC	METALLIC	METALICO	METALLICO
GREEN	VERT	GRUN	VERDE	VERDE
SILVER	ARGENT	SILBERN	PLATA	ARGENTO
BLACK	NOIR	SCHWARZ	NEGRO	NERO
ORANGE	ORANGE	ORANGE	NARANJADO	ARANCIO
AMBER	AMBRE	BERNSTEINFARBEN	AMBAR	AMBRA
ALUMINUM	ALUMINIUM	ALUMINIUMFARBEN	ALUMINIO	ALLUMINIO
GLOSS	LUSTRE	GLANZENDES	BRILLANTE	BRILLANTE
FLAT	TERNE	GLANZLOSES	APAGADO	OPACO

ACADEMY
HOBBY MODEL KITS

2131

Copyright 1995 Academy Plastic Model Co., Ltd.
273-64, Suyu-dong, Kangbuk-ku, Seoul, Korea FAX: 82-2-997-3003

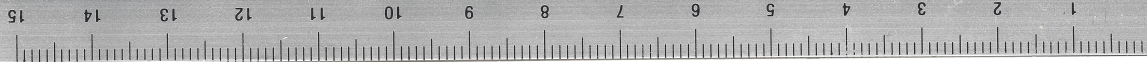

ACADEMY
HOBBY MODEL KITS

SU-27B FLANKER #2131

1. Yellow circular stickers with a radiation symbol.

2. Yellow rectangular stickers.

3. Yellow rectangular stickers.

4. Small rectangular stickers with a '6' and a dashed line.

5. Small rectangular sticker with a '5' and a vertical bar.

6. Yellow rectangular stickers with assembly diagrams.

7. Large red numerals '08 08'.

8. A grid of 12 red 'X' symbols arranged in 3 rows and 4 columns.

9. Red triangular wing section with white teeth.

10. Assembly instructions for parts 10 and 11.

11. Yellow rectangular stickers with assembly diagrams.

12. Yellow circular stickers with a 'Y' symbol.

13. Yellow rectangular sticker with assembly diagrams.

14. Yellow rectangular sticker with a 'Y' symbol.

15. Large red numerals '08 08'.

16. Large blue fuselage section.

17. Blue wing section.

18. Red triangular wing section with white teeth.

19. Large blue fuselage section.

20. Blue triangular wing section.

21. Red star.

22. Blue triangular wing section.

23. Three red stars.

24. Grid of 12 red 'X' symbols arranged in 3 rows and 4 columns.

25. Blue wing section.

26. Small rectangular stickers with assembly diagrams.

27. Small rectangular sticker with assembly diagrams.