

Revell
MONOGRAM

F-18C HORNET

1/48 SCALE 1/48 ECHELLE ESCALA 1/48

KIT 4821

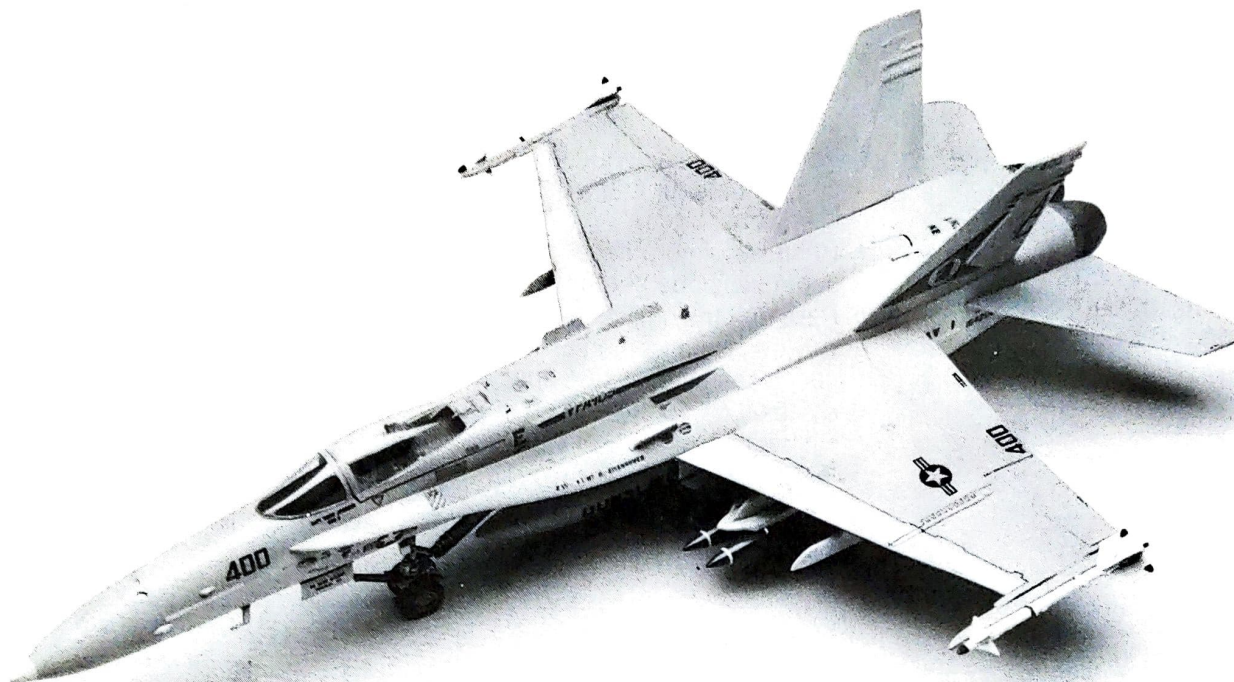

85482120201

As its unusual designation indicates, the F/A-18 Hornet is equally capable of performing both the air-to-air fighter and air-to-ground attack missions. This multi-role combat aircraft is now one of the most important weapon systems in America's arsenal of defense.

Originally developed from the YF-17, the F/A-18A single-seat version and the F/A-18B two-seat variant became the first Hornets to reach operational service. Although these early versions of the Hornet remain in service, the F/A-18C single-seater and F/A-18D two-seater have become operational with improved capabilities. While the F/A-18D is a specialized version in service mainly with the Marines, it is the F/A-18C which now equips most front line fighter/attack squadrons in both the Navy and Marines. This version has been produced in greater numbers than any other Hornet variant.

The versatility of the F/A-18C was demonstrated on January 17, 1991, during the opening hours of Operation Desert Storm. As two Hornets prepared to attack an Iraqi airfield with Mk 84, 2,000-pound bombs, they were attacked by two Iraqi MiG-21 Fishbeds. One of the F/A-18Cs destroyed the first MiG with an AIM-9 Sidewinder missile, while the second Hornet shot down the other MiG with an AIM-7 Sparrow missile. The two F/A-18Cs retained their bombs during the engagement, and went on to attack the airfield after destroying the two Fishbeds.

The F/A-18C, which your Monogram model represents, is capable of carrying a wide variety of weapons. Standard and laser-guided

bombs ranging in size from 500 pounds to 2,000 pounds can be delivered by the Hornet to destroy targets on the ground. For suppressing enemy air defenses, the AGM-88 HARM anti-radiation missile can be employed, and in the anti-shipping role, the AGM-84 Harpoon missile is used. Various cluster bomb units can also be delivered against a variety of targets. For the air-to-air mission, the AIM-9 Sidewinder, AIM-7 Sparrow, and AIM-120 AMRAAM missiles can be used. Other weapons, ranging from the stand-off land attack missile (SLAM) to the Walleye II electro-optically guided glide bomb, and from mines to rocket pods are also certified for use on the F/A-18C. All of these weapons are carried externally and are in addition to the aircraft's internal 20-mm cannon.

In addition to weapons, the F/A-18C can carry three different pod systems to help it employ its ordnance in any weather conditions and during the day or night. These pods help the pilot navigate, locate and designate the target, guide weapons, and even photograph the results of the attack. Few aircraft have this kind of sophistication.

This kit provides markings for two F/A-18Cs. One is from VFA-105, which is known as the "Gunslingers." This squadron is based aboard the USS DWIGHT D. EISENHOWER, CVN-69. The aircraft is shown in the colorful markings it carried while assigned to the commander of the air wing (CAG) during May 1994. The second aircraft was assigned to CDR Gary Koger, the commanding officer of the "Stingers" of VFA-113. The markings represent those painted on the aircraft while it was assigned to the USS INDEPENDENCE, CV-62, during Operation Desert Shield.

READ THIS FIRST

- Study the assembly drawings.
- Each plastic part is identified by a number.
- Scrape plating from areas to be cemented.
- Check the fit of each piece before cementing into place.
- Do not use too much cement to join parts.
- Use only cement for polystyrene plastic.
- Model may be painted to match photos on box.
- Scrape paint from areas to be cemented.
- For better paint and decal adhesion, wash the plastic parts in a mild detergent solution. Rinse and let air dry.

LEA ESTO ANTES DE EMPEZAR

- Estudie los dibujos de ensamblaje.
- Cada pieza de plástico se identifica por un número.
- Verifique que cada pieza encaje bien antes de posición.
- No use demasiado pegamento para unir las piezas.
- Use unicamente pegamento para plástico de poliestirina.
- El modelo puede pintarse de acuerdo con las fotografías de la caja.
- Permita que se seque la pintura completamente antes de tocar las piezas.
- Raspe la pintura de las superficies que serán pegadas.
- Para una mejor fijación de la pintura y de las calcomanías, lávense las piezas plásticas en una solución de detergente suave. Enjuaguense y dejense secar al aire.

LISEZ CE QUI SUIT AVANT DE COMMENCER LE MONTAGE

- Etudier les schémas d'assemblage.
- Chaque pièce plastique porte un numéro d'identification.
- Contrôler que chaque pièce soit bien cinfirmé avante de la coller a sa place.
- N'utilisez pas trop de colle pour réunir les pieces.
- Utilisez uniquement une colle spéciale pour polystyrene.
- Le model peut etre peint conformément aux photos sur la boite.
- Laissez sécher la peinture complètement, avant de manipuler les pièces.
- Grattez la peinture sur les surfaces devante etre collées. Pour assurer la meilleure adhésion possible de la peinture et des decalomanies, laver les pieces de plastique avec une légère solution savonneuse. Rinse et laissez secher a l' aire.



**DO NOT CEMENT
NE PAS COLLER
NO USE PEGAMENTO**



**REPEAT SEVERAL TIMES
A REPETER PLUSIEURS FOIS
REPITA VARAIS VECES**



**ALTERNATIVE ASSEMBLY
ENSAMBLE ALTERNATIVO
ENSEMBLAGE ALTERNATIVE**



**REMOVE AND THROW AWAY
A RETIRER ET JETER
QUITE Y TIRE**



**DECAL (DIP IN WATER)
DECALCOMANIE (A PLONGER DANS L'EAU)
DECALCOMANIA (MOJÉ CON AGUA)**

FLAT BLACK	NOIR TERNE	NEGRO APAGADO
FLAT WHITE	BLANC	BLANCO
YELLOW	JAUNE	AMARILLO
TAN	BRUN CLAIR	CANELA
GREEN	VERT	VERDE
OLIVE DRAB	VERT OLIVE	ACEITUNADO
DARK GRAY	GRIS FONCE	GRIS OSCURO
STEEL	METALLIC	METALICO
GUN METAL	METALLIC	METALICO
RED	ROUGE	ROJO
GLOSS WHITE	BLANC	BLANCO

A COMPLETE GUIDE FOR PAINTING THIS AIRCRAFT APPEARS AT THE END OF THIS INSTRUCTION BOOKLET.

Revell Model Kits has put forth every effort to create and manufacture the finest model kit available. If a part may be missing, please write to:

REVELL MODEL KITS
Consumer Service
Department
301 North Third Avenue
Des Plaines, Illinois 60016

Be sure to include the kit number, part number, description, and your return address.

**If you have any problems building this model,
call our modeling tips hotline at:
(800) 833-3570**

1 COCKPIT ASSEMBLY

- ★
- GREY PANEL WITH BLACK INSTRUMENTS
- GRAUE SCHALTAFEL MIT SCHWARZEN INSTRUMENTEN
- PANEL GRIS CON INSTRUMENTOS NEGROS

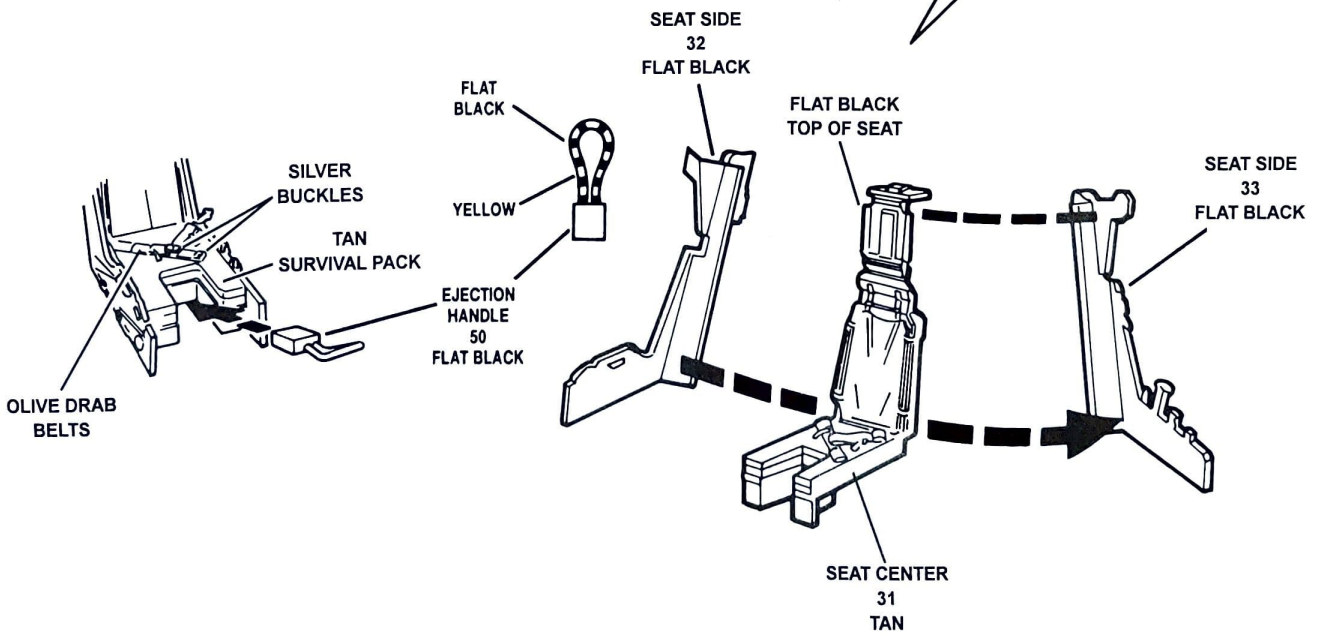
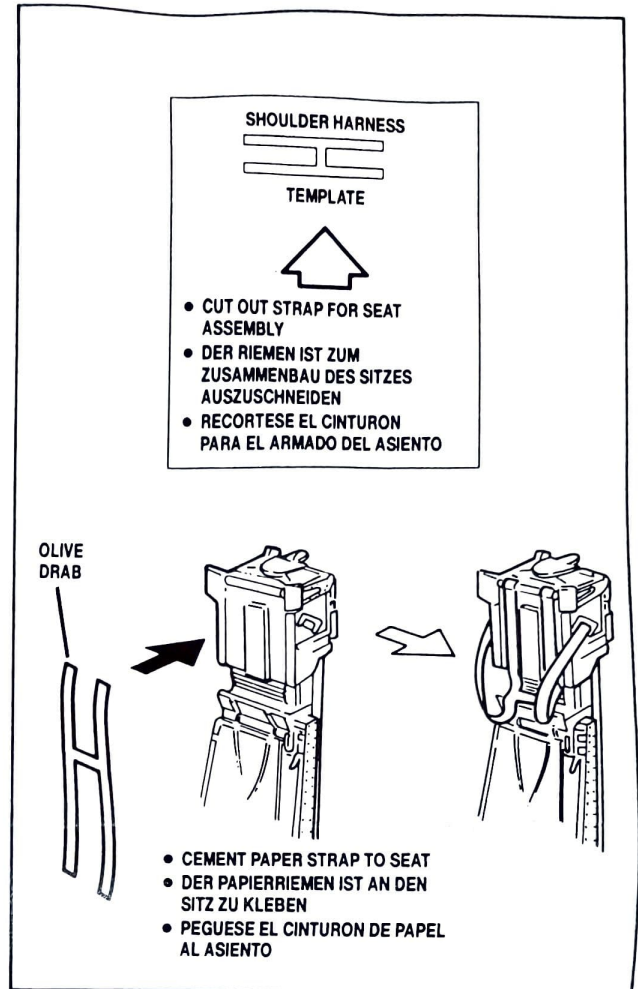
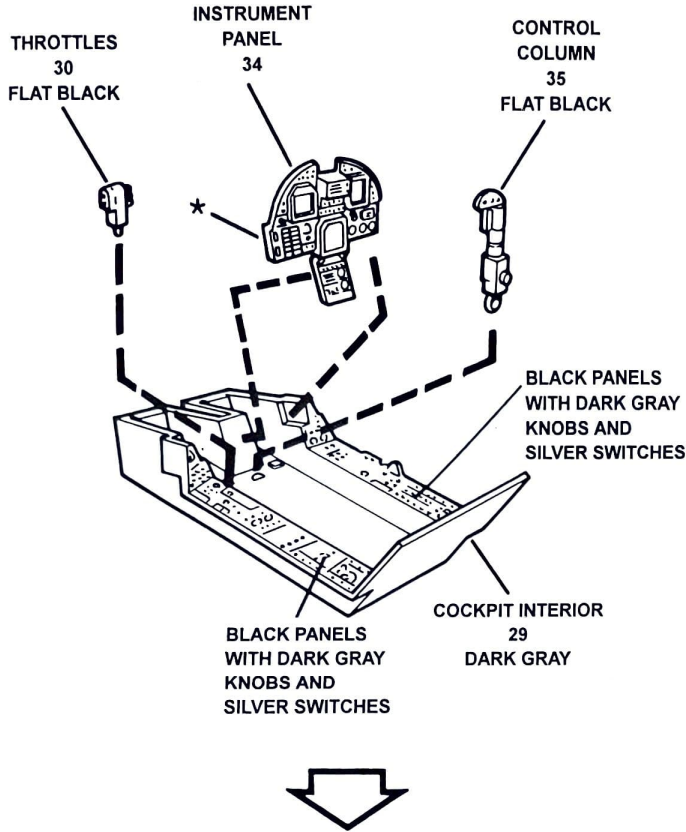

2

COCKPIT ASSEMBLY CONT.

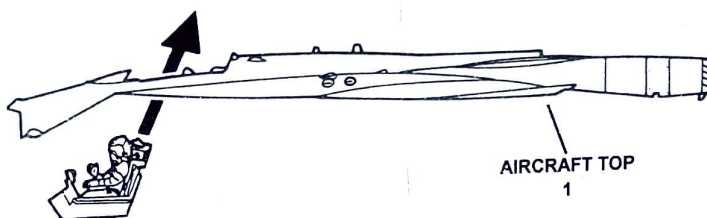
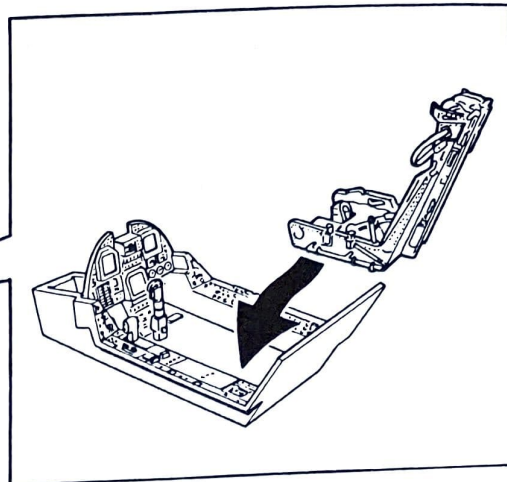
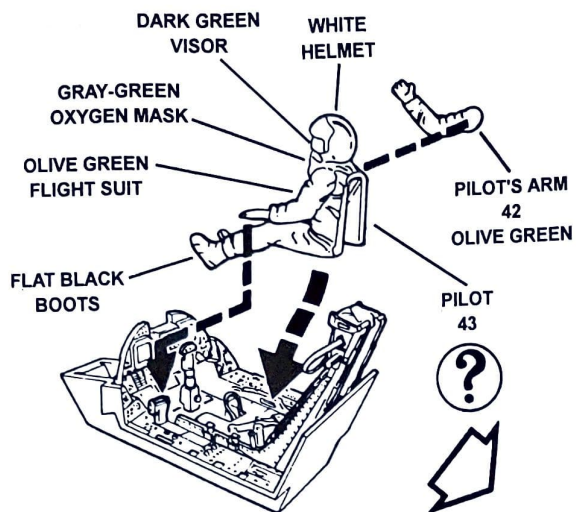

3

FUSELAGE ASSEMBLY

- SOME DETAILS OMITTED
- CERTAINS DETAILS SUPPRIMES
- ALGUNOS DETALLES OMITIDOS

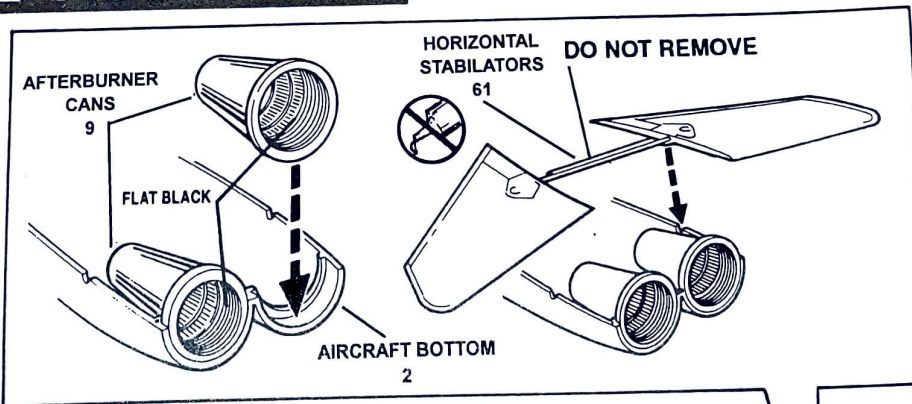

AIRCRAFT BOTTOM
2

- OPTIONAL: CLEAN OUT HOLES FOR MOUNTS 47 IN STEP 5
- WAHLWEISE: DIE LÖCHER SIND FÜR DIE STÜTZEN 47 IN STUFE 5 AUSZUSCHNEIDEN
- OPCIONAL: LIMPIENSE LOS AGUJEROS PARA LOS SOPORTES 47 EN EL PASO 5

- OPTIONAL: CLEAN OUT HOLES FOR TANK IN STEP 4
- WAHLWEISE: DIE LÖCHER SIND FÜR DEN TANK IN STUFE 4 AUSZUSCHNEIDEN
- OPCIONAL: LIMPIENSE LOS AGUJEROS PARA EL TANQUE EN EL PASO 4

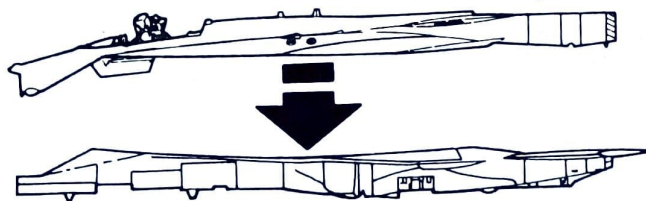
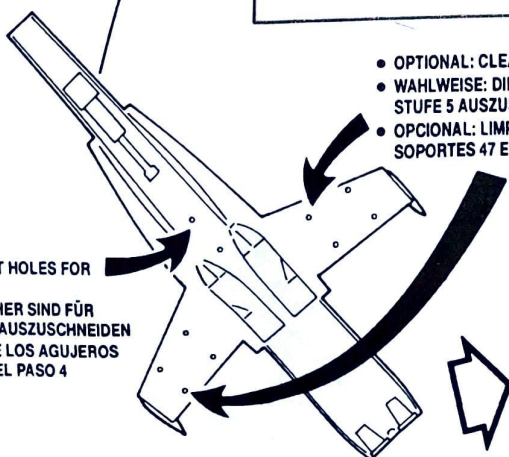

4 FUSELAGE ASSEMBLY CONT.

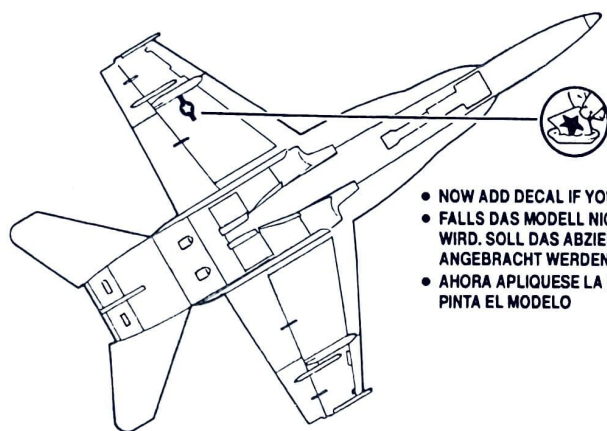
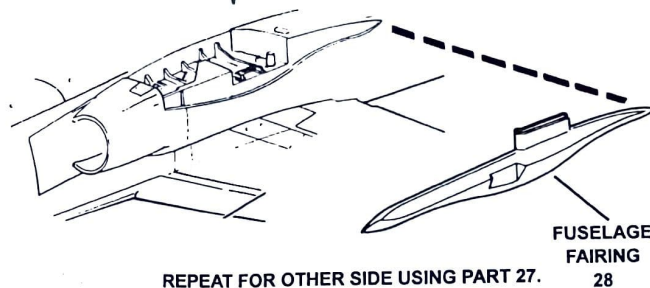
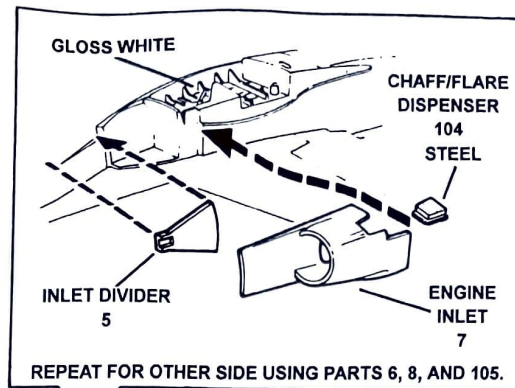
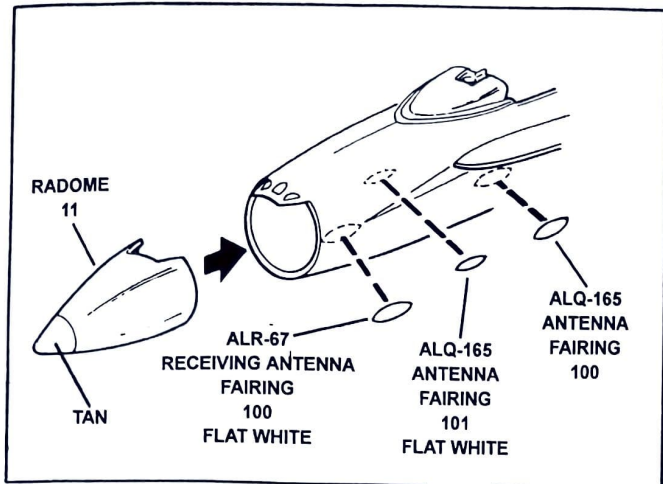

- NOW ADD DECAL IF YOU DO NOT PAINT MODEL
- FALLS DAS MODELL NICHT ANGESTRICHEN WIRD. SOLL DAS ABZIEHBILD JETZT ANGEBRACHT WERDEN
- AHORA APLIQUESE LA CALCOMANIA SI NO SE PINTA EL MODELO

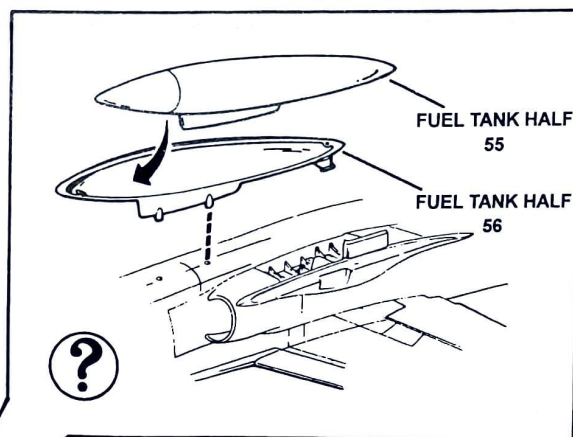

- ALL DOOR EDGES RED
- ALLE TÜRRÄNDER ROT
- LOS BORDES DE LAS PUERTAS SON ROJOS



- DETAILS OMITTED FOR CLARITY
- EINZELHEITEN ZWECKS KLARHEIT AUSGELASSEN
- DETALLES OMITIDOS PARA MAYOR CLARIDAD

5 UNDERWING STORES ASSEMBLY

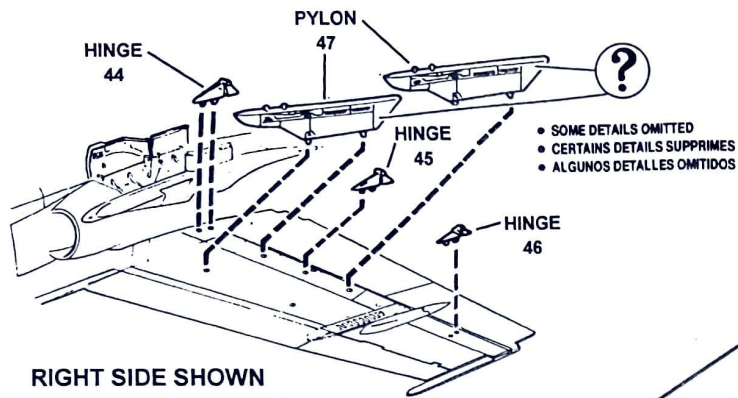

SEE THE LAST PAGE OF THIS INSTRUCTION BOOKLET FOR INFORMATION ABOUT PAINTING THE BOMBS.

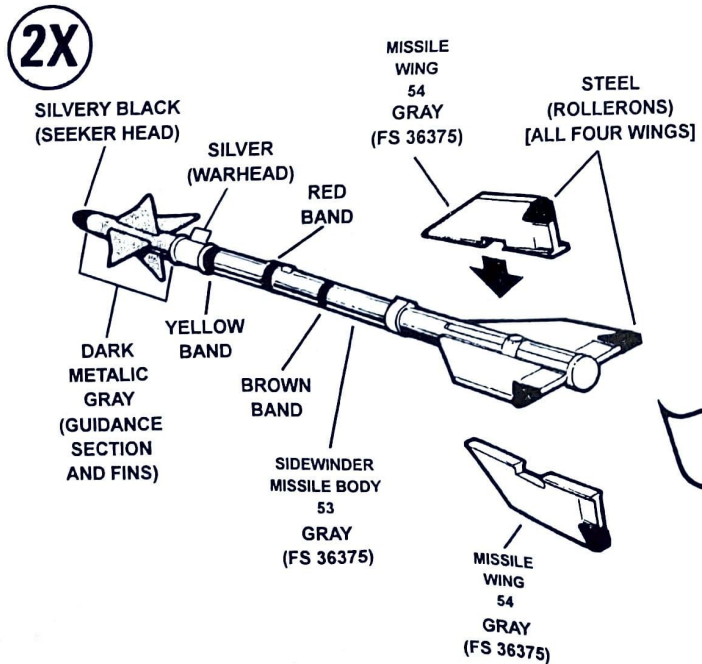
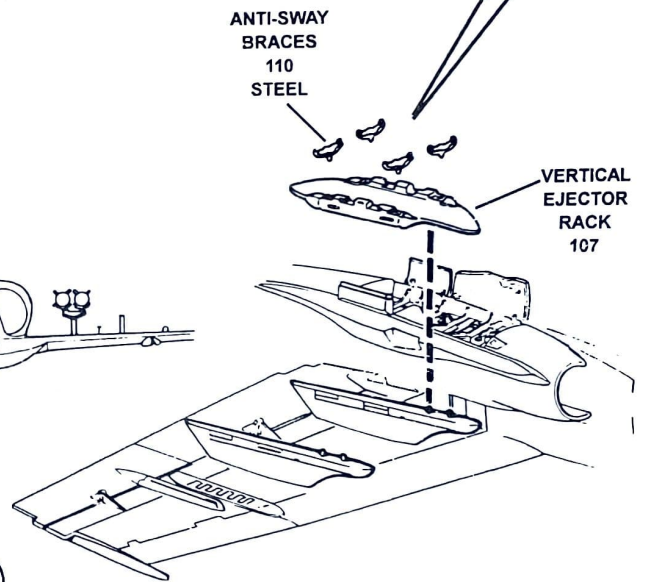
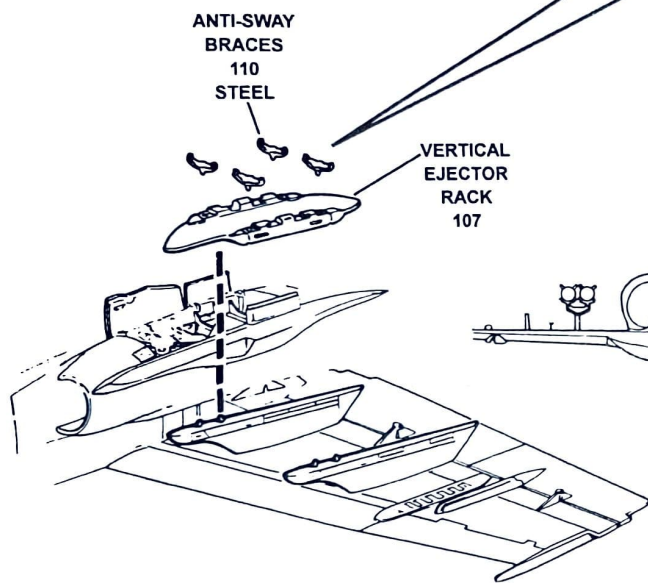
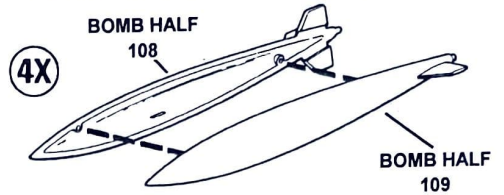

6 LANDING GEAR

MAIN GEAR

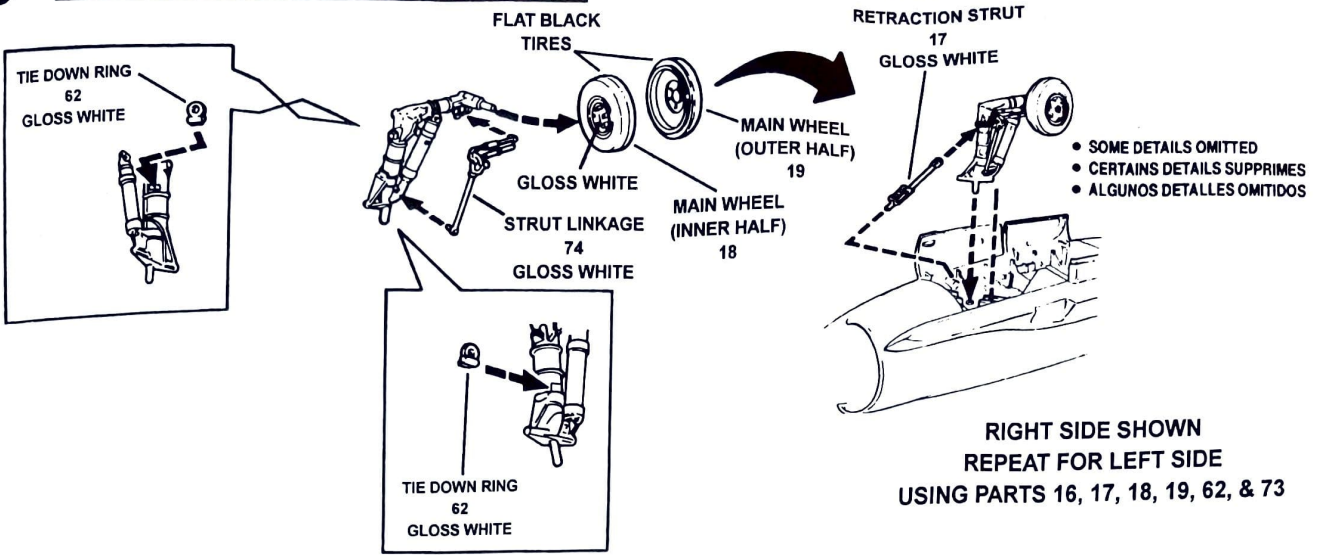

NOSE GEAR

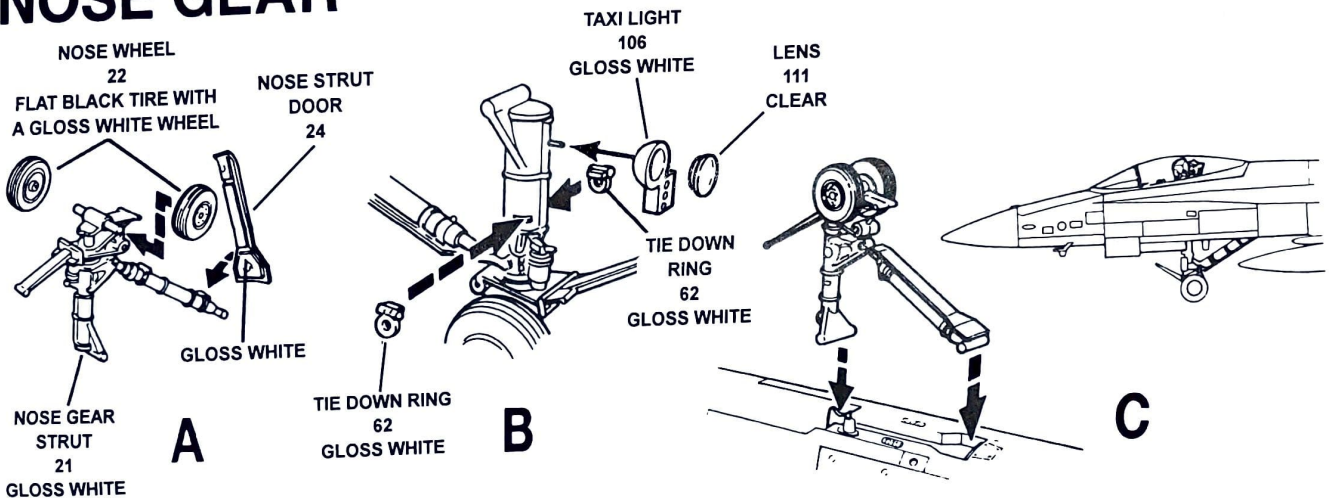

7 VERTICAL TAIL ASSEMBLY

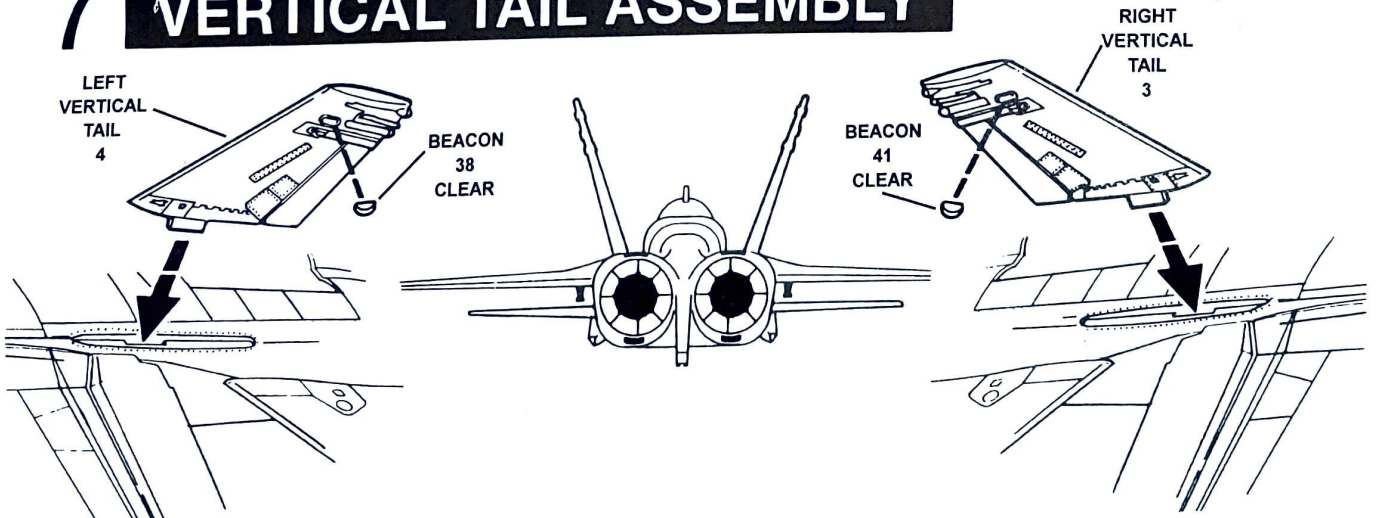

8 FINAL DETAILS

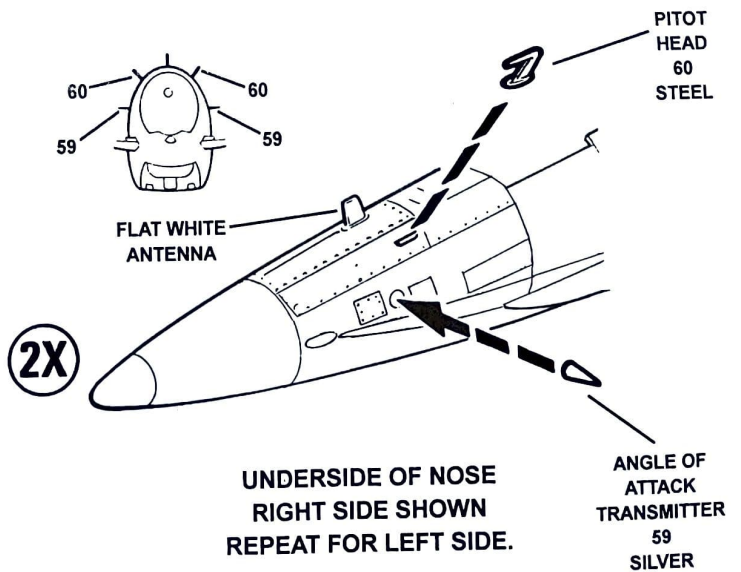
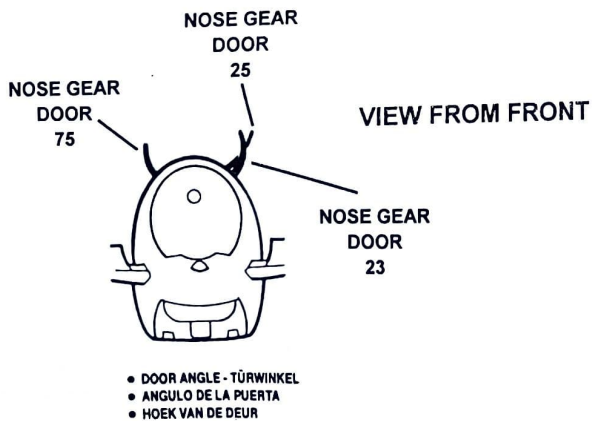
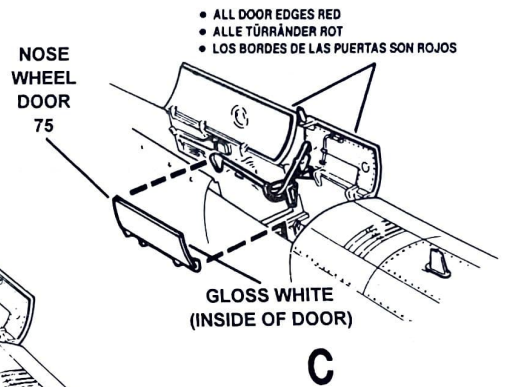
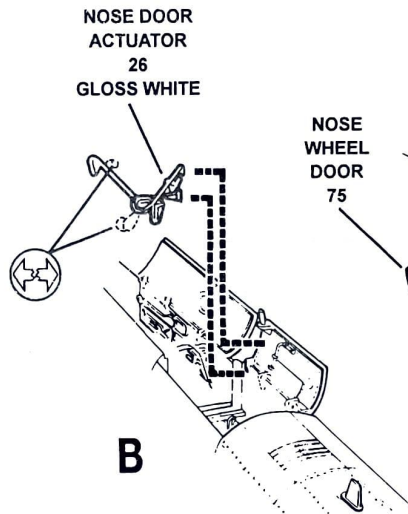
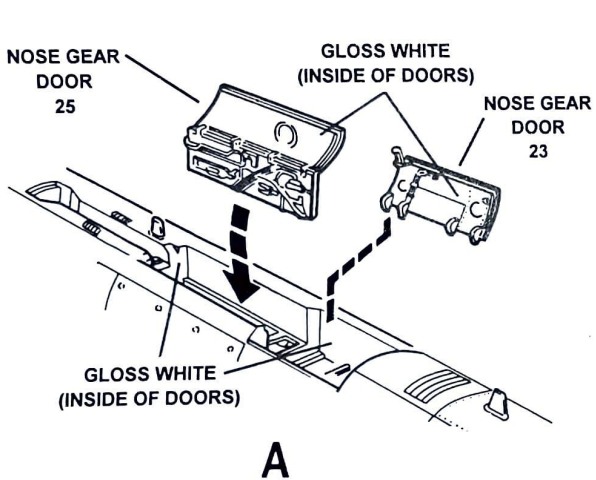
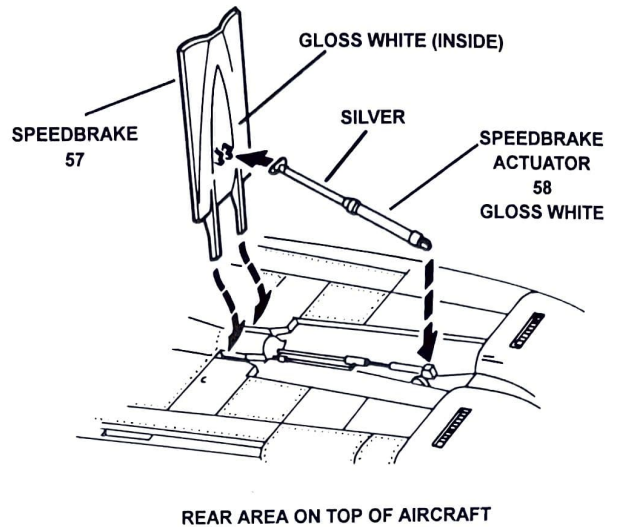
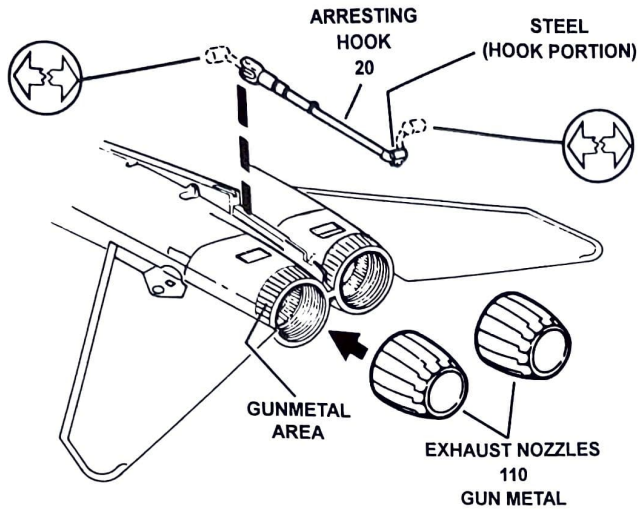

9 CANOPY DETAILS

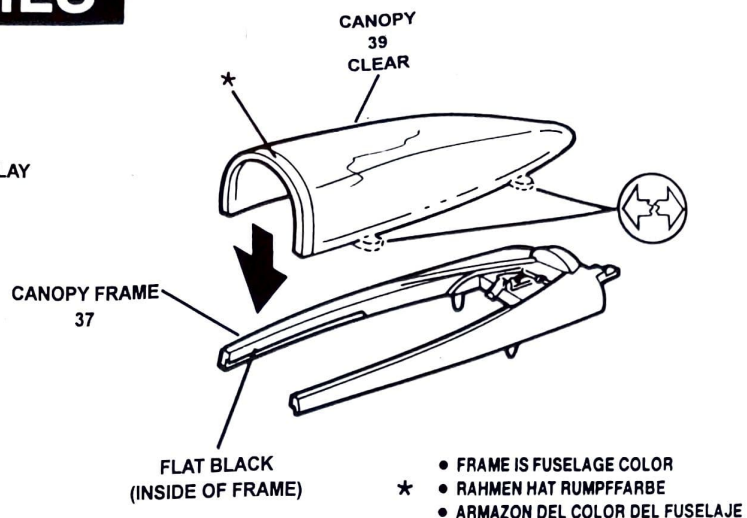
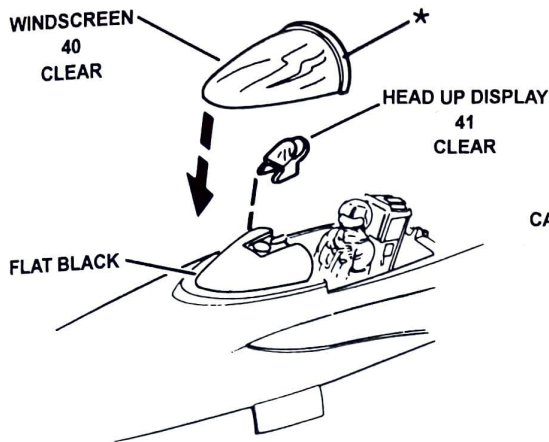

- FRAME IS FUSELAGE COLOR
- * • RAHMEN HAT RUMPPFARBE
- ARMAZON DEL COLOR DEL FUSELAJE



CLOSED POSITION

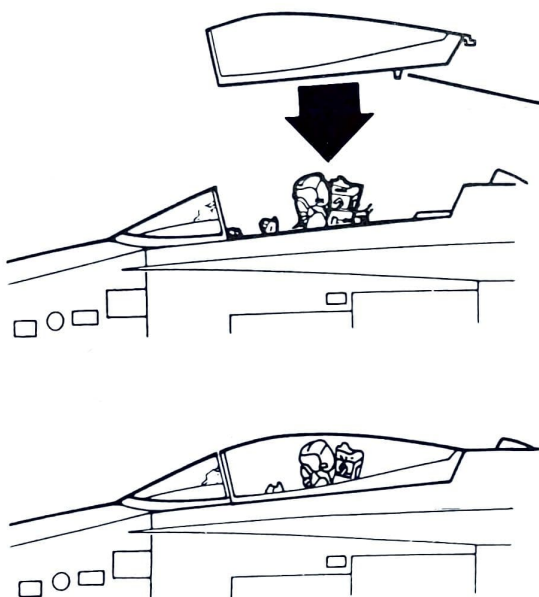

OPEN POSITION

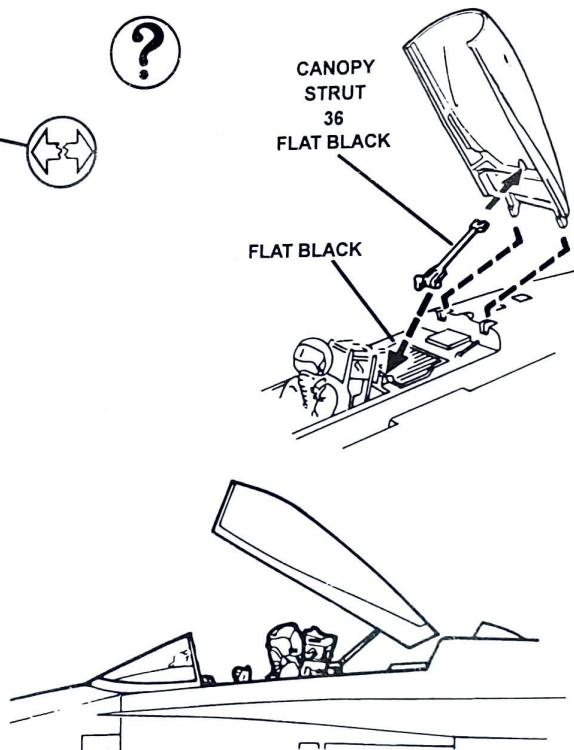

CANOPY PAINTING INFORMATION

- CANOPY DETAIL—MASK ENTIRE CANOPY WITH A DULL FINISH ACETATE MENDING TAPE. CAREFULLY CUT THE TAPE FROM AREAS TO BE PAINTED. PAINT THE EXPOSED PARTS AND ALLOW TO DRY. REMOVE THE REMAINING TAPE.
- FÜR DAS KUPPELDACH—DAS GESAMTE KUPPELDACH MIT MATTEM AZETATKLEBSTREIFEN VERKLEIDEN. DEN KLEBSTREIFEN SORGFÄLTIG VON DEN ZU ST. EICHENDEN FLÄCHEN ABSCHNEIDEN. DIE FREIEN TEILE STREICHEN UND TROCKNEN LASSEN. DEN ÜBRIGEN KLEBSTREIFEN ENTFERNEN.
- DECORACION DE LA CARLINGA—CUBRIR ENTERAMENTE LA CARLINGA CON LA CINTA DE PEGAR DE COLOR ACETATO APAGADO. RECORTE CUIDADOSAMENTE LA CINTA. DE LAS AREAS A SER PINTADAS. PINTÉ LAS PARTES QUE QUEDEN EXPUESTAS Y DEJE SECAR. RETIRE LA CINTA DE PEGAR.

F/A-18C HORNET DECAL PLACEMENT AND PAINTING GUIDE

DECAL APPLICATION INSTRUCTIONS



- 1.) Wash plastic parts in mild detergent solution, then rinse and let dry.
- 2.) Cut the desired decal from the sheet.
- 3.) Dip the decal in water for a few seconds.
- 4.) Place the wet decal on a paper towel.
- 5.) Wait until the decal is movable on its backing paper.
- 6.) Place the decal in position on the model with its face up, then slide the backing away.
- 7.) Press out any air bubbles with a soft damp cloth.
- 8.) The milkiness that may appear is for better decal adhesion, but will dry clear.
- 9.) Wipe away any excess adhesive.
- 10.) Do not touch the decal until it is dry.

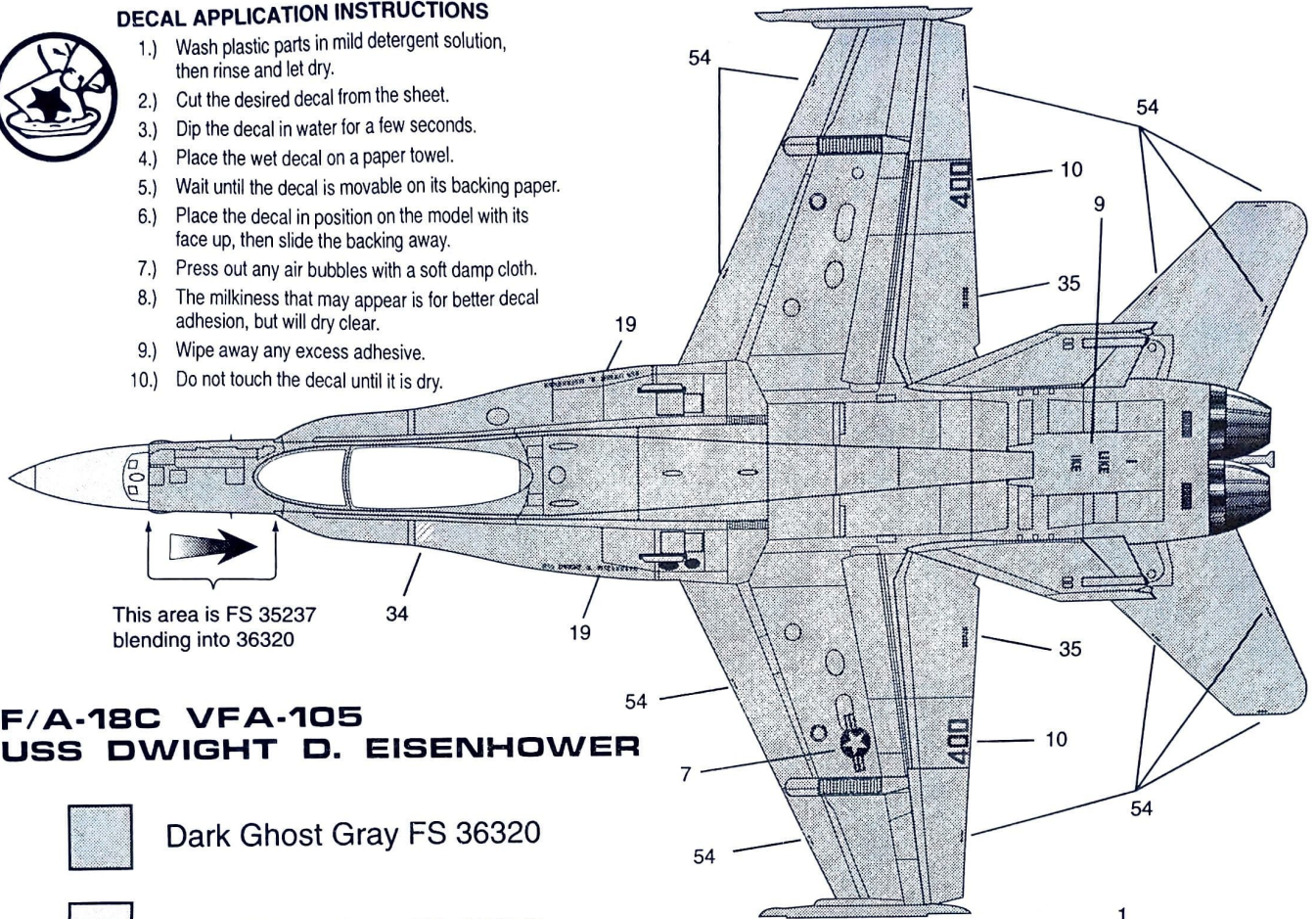

This area is FS 35237
blending into 36320

F/A-18C VFA-105 USS DWIGHT D. EISENHOWER



Dark Ghost Gray FS 36320



Light Ghost Gray FS 36375

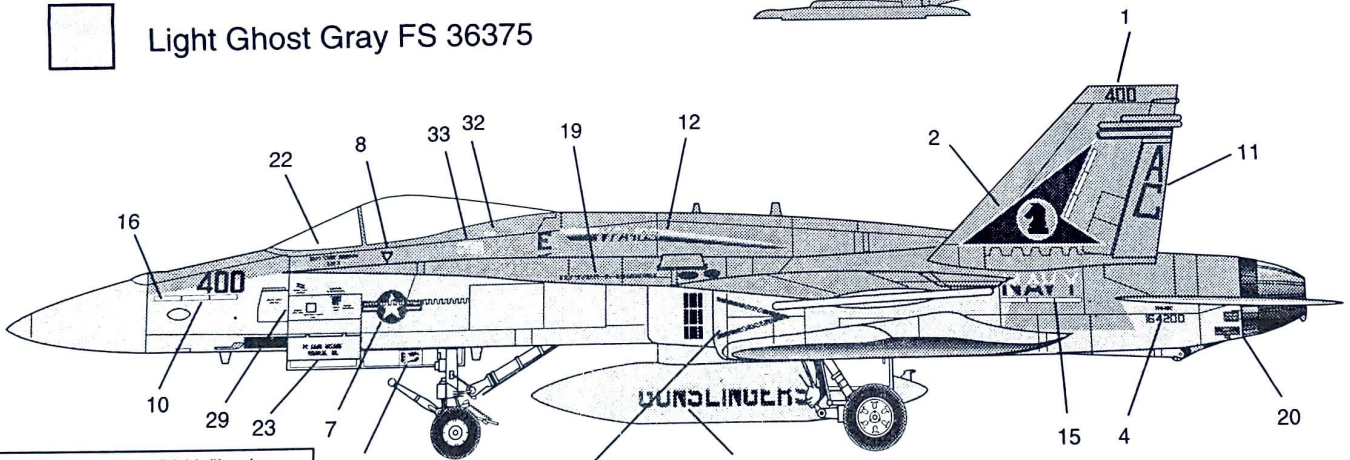

Note: Name "VIDADLIA" is shown as it appeared on the nose wheel door. It is not an error on the decal.

Note that left intake warning is higher than the one on the right.

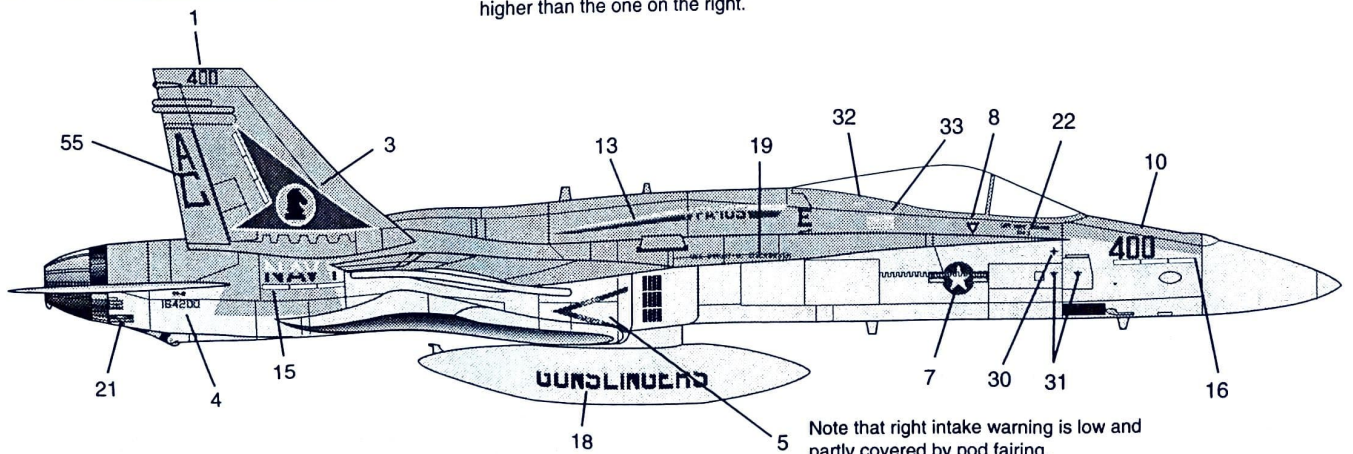

Note that right intake warning is low and partly covered by pod fairing.



DECAL PLACEMENT

The low visibility camouflage scheme used on the Hornet has little contrast between the color of the plane and the markings. On the actual airplane, you must look very close to see the markings. The decals in this kit are designed for the same effect.

This area is FS 35237
blending into 36320

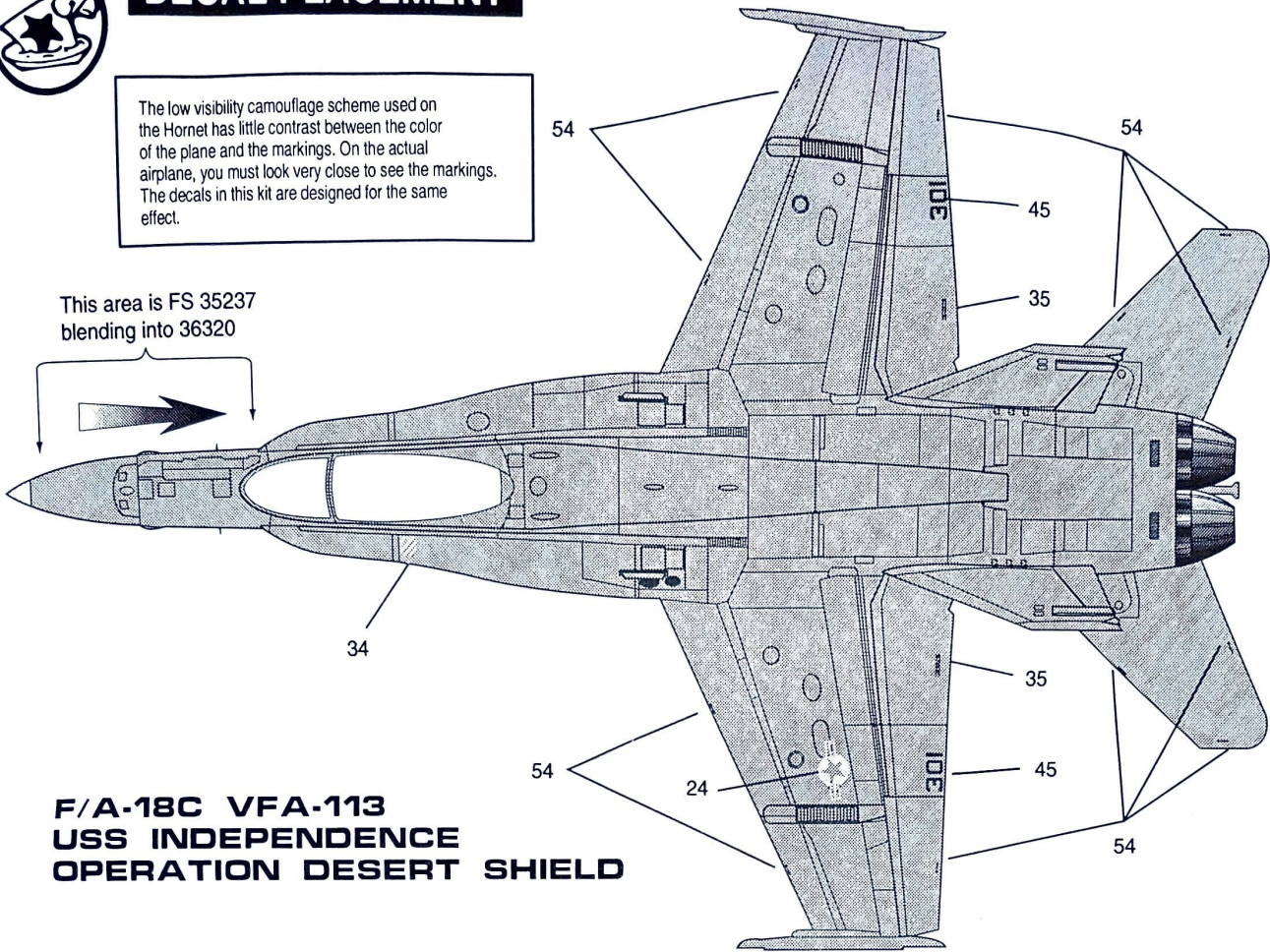

F/A-18C VFA-113 USS INDEPENDENCE OPERATION DESERT SHIELD

Trim tapelite from decal 15
for this version.

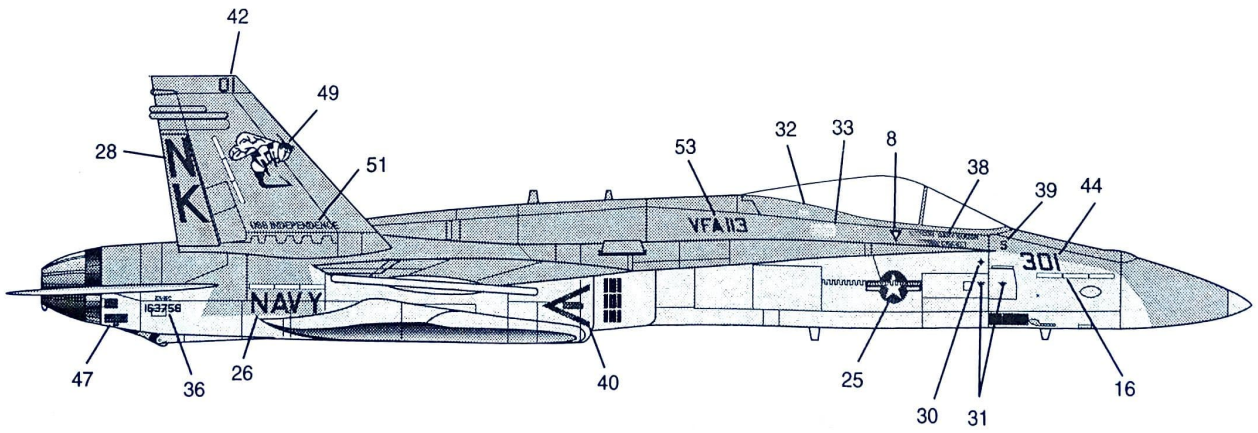
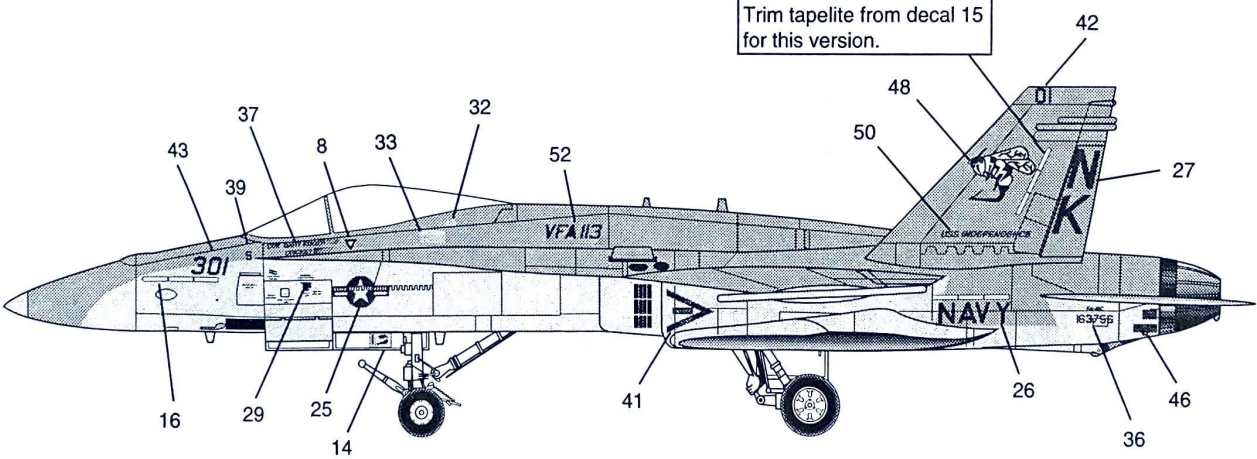



BOTTOM VIEWS

VFA-105

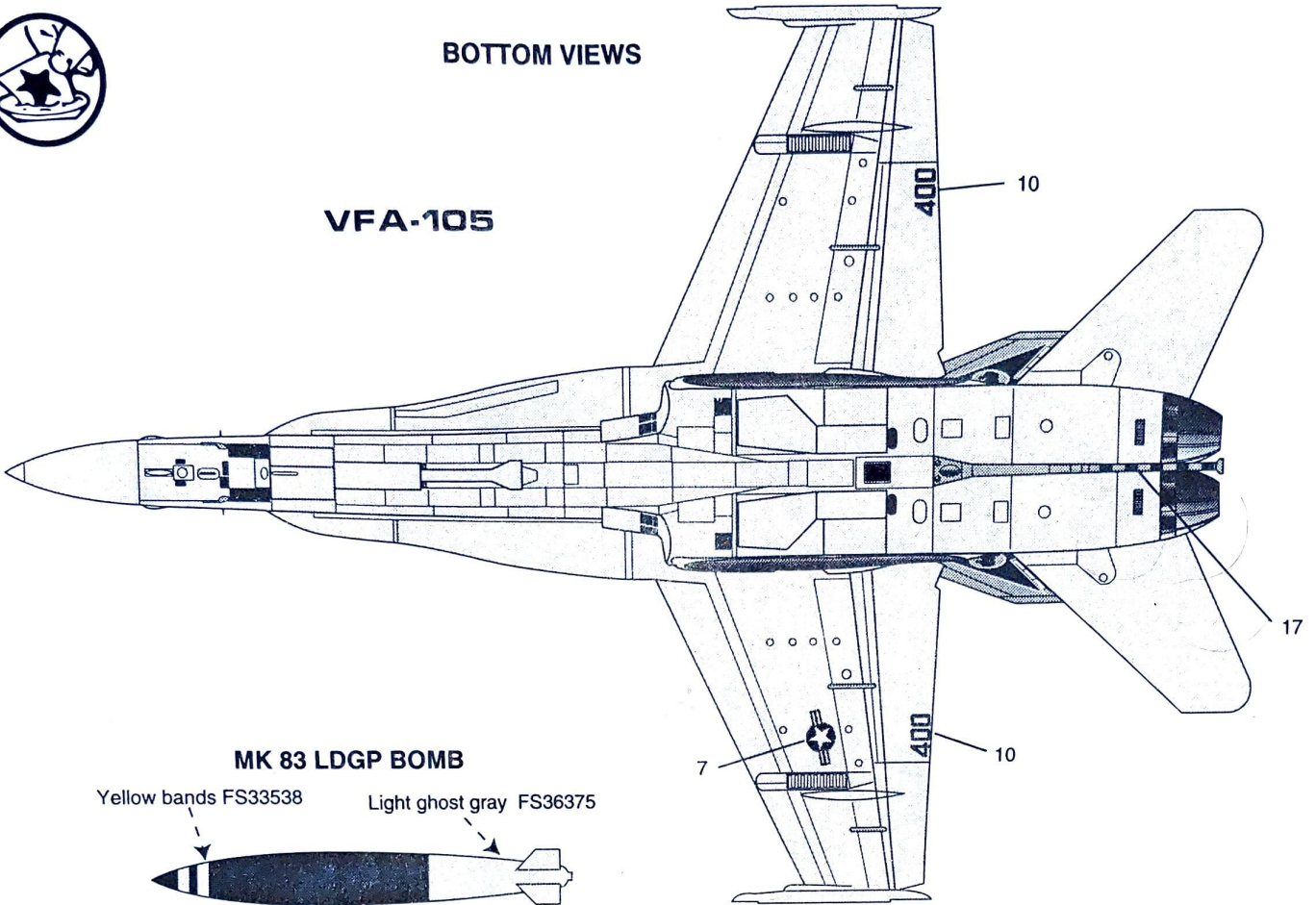

MK 83 LDGP BOMB

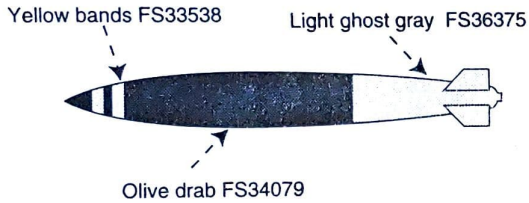

VFA-113

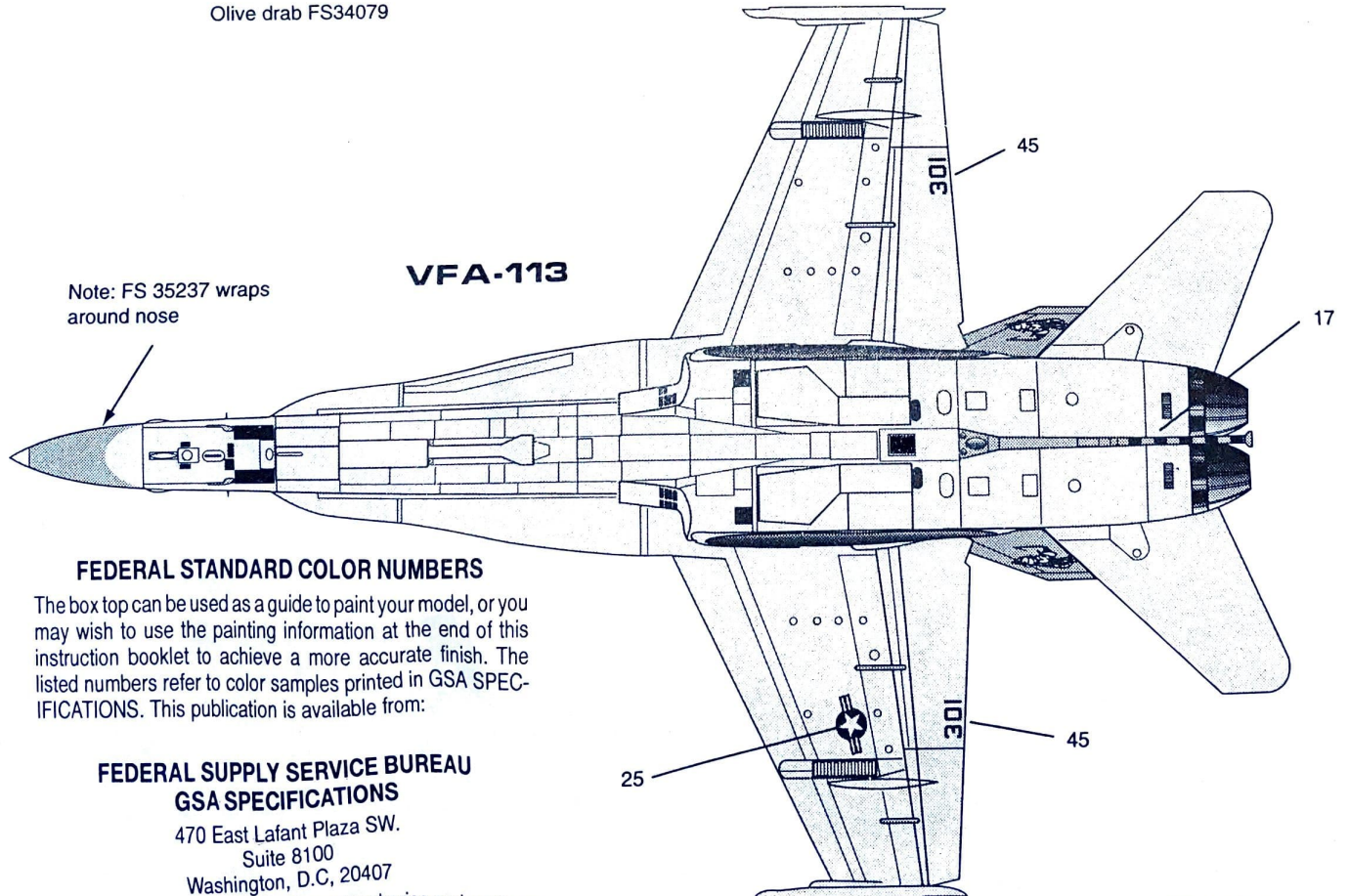

Note: FS 35237 wraps around nose

FEDERAL STANDARD COLOR NUMBERS

The box top can be used as a guide to paint your model, or you may wish to use the painting information at the end of this instruction booklet to achieve a more accurate finish. The listed numbers refer to color samples printed in GSA SPECIFICATIONS. This publication is available from:

FEDERAL SUPPLY SERVICE BUREAU GSA SPECIFICATIONS

470 East Lafant Plaza SW.
Suite 8100
Washington, D.C., 20407

Write to GSA for information regarding current price and availability.