**SH 72133****F2A-2 Buffalo "Yellow Wing"****1/72****(GB)**

The ambitious, originally body building Brewster company became famous mainly by the F2A Buffalo airplane. The designers D. T. Brown and R. D. MacCart projected in 1936 an all-metal mid-winged fighter with retractable undercarriage for US Navy contest instant on a fighter for aircraft carriers. US Navy looked for a replacement of antiquated F3F Biplane fighters. The prototype with the factory marking model 139 and military marking XF2A-1 took off in December 1937 US Navy ordered fifty four pieces under the marking F2A-1 (factory marking model 239). Used were only partially, the rest was sold to Finland. In March 1939 US Navy ordered at the Brewster company the building in of the Wright R-1820-40 engine of this version and against the original R-1820-22 version a higher power output. Arised so the prototype of the XF2A-2 (MODEL 339) version. It got the new Curtiss Electric propeller with electrical blade adjustment. Realized where also internal adaptations. US Navy ordered the F2A-2 series in a quantity of forty three pieces, in substitution of the F2A-1 machines sold to Finland. The first thirty pieces hat an armament of three 12,7 mm and one 7,62 mm machine guns. The further planes received an armament of four 12,7mm machine guns.

US navy ranged F2A-2 in the VF-2 flight on the USS Lexington and VF-3 on USS Saratoga. Some planes near used by the reconnaissance wing VS-201 from the escort aircraft carrier USS long island. The machines were later passed over to flights of us US Marines. The served finally for training in training centre of US Navy on USA territory.

Technical data.

Span: 10,67 m, Length: 7,80 m: Height: 3,56 m, Max. Speed: 520 km/h in 5030 altitude, Range: 1633 km/h, Armament: 3x12,7 mm machine gun, 1x7,62mm machine gun (or 4x 12,7mm machine gun).

(CZ)

Ambiciózní, původně karosářská společnost Brewster se proslavila hlavně letounem F2A Buffalo. Konstruktéři D. T. Brown a R. D. MacCart navrhli v roce 1936 celokovový stíhací střednoplošník se zatahovacím podvozkem pro soutěž US Navy na stíhačku pro letadlové lodě. US Navy hledalo náhradu za zastarávající dvojplošné stíhačky F3F.

Prototyp s továrním označením model 139 a vojenským XF2A-1 vzlétl v prosinci 1937. US Navy objednalo padesát čtyři kusů pod označením F2A-1 (tovární označení model 239). Použilo jen část, zbytek prodalo Finsku. V březnu 1939 objednalo US Navy u firmy Brewster zabudování motoru Wright R-1820-40 do draku XF2A-1. Motor této verze měl proti původní verzi R-1820-22 vyšší výkon. Vznikl tak prototyp verze XF2A-2 (model 339). Dostal novou vrtuli Curtiss Electric s elektrickým stavěním listů. Byly provedeny i další vnitřní úpravy. US Navy objednalo sérii F2A-2 ve výši čtyřiceti tří kusů, náhradou za stroje verze F2A-1 prodané Finsku. Prvních třicet kusů mělo výzbroj tři kulometů 12,7 mm a jednoho 7,62 mm. Další dostaly výzbroj čtyř kulometů 12,7 mm. US navy zařadilo F2A-2 k letce VF-2 na USS Lexington a VF-3 na USS Saratoga. Několik používala průzkumná peruč VS-201 z eskortní letadlové lodi USS Long Island. Později byly stroje předány letkám US Marines. Dosloužily k výcviku ve výcvikových střediscích US Navy na území USA.

Technická Data:

rozpětí: 10,67 m, délka: 7,80 m, výška: 3,56 m, max. rychlost: 520 km/h ve výšce 5030 m, dolet 1633 km, výzbroj: 3x kulomet 12,7 mm, 1x kulomet 7,62 mm (nebo 4 x kulomet 12,7 mm)

PLASTIC PARTS (A)

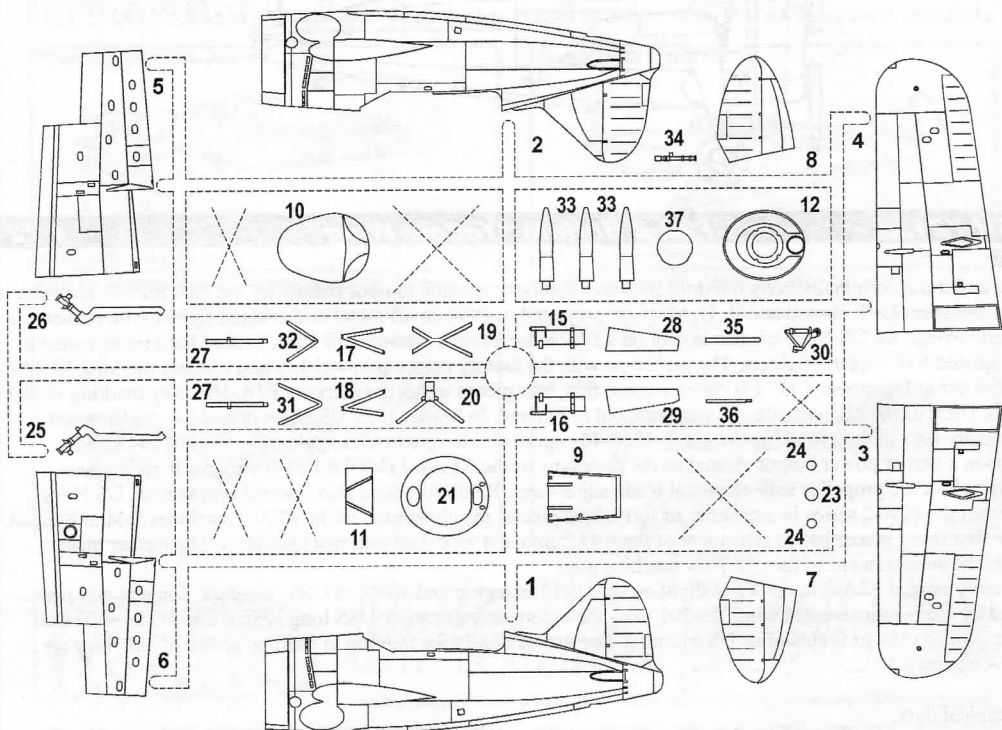

CLEAR PARTS (C)

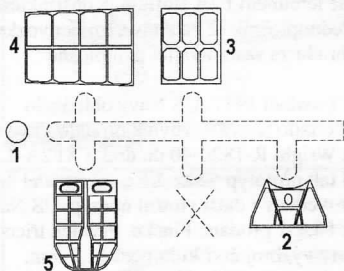

POLYURETHAN PARTS (B)

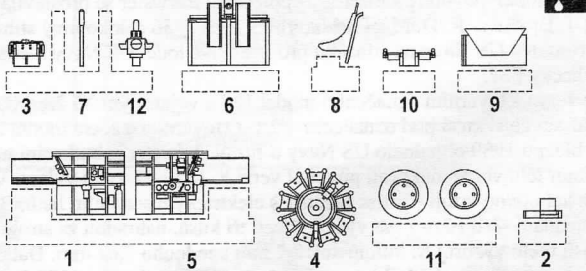

Možnost volby
Optional
Nach belieben
Option



Oddělit
Cut with knife
Mit Messer schneiden
Couper au couteau



Lepidlo na kov
Glue for metal
Metallkleber
Colle a metal



Ohnout
Bend
Biegen
Courber



Vyrobít nové
Scratch build
Fertigstellen
Achever



1

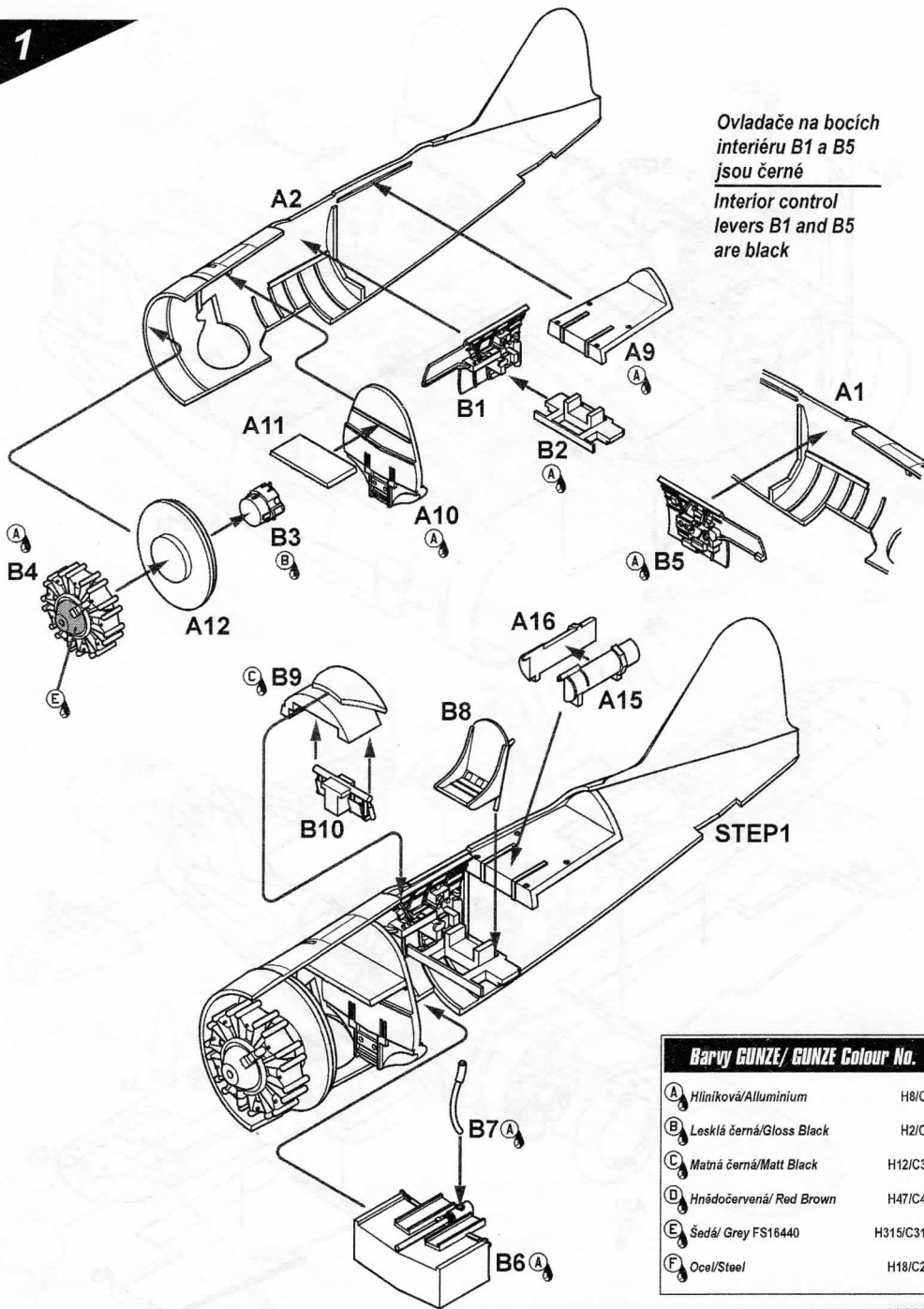

Ovladače na bocích
interiéru B1 a B5
jsou černé
Interior control
levers B1 and B5
are black

Barvy GUNZE/ GUNZE Colour No.

A	Hliníková/Aluminium	H8/C8
B	Lesklá černá/Gloss Black	H2/C2
C	Matná černá/Matt Black	H12/C33
D	Hnědočervená/ Red Brown	H47/C41
E	Šedá/ Grey FS16440	H315/C315
F	Ocel/Steel	H18/C28

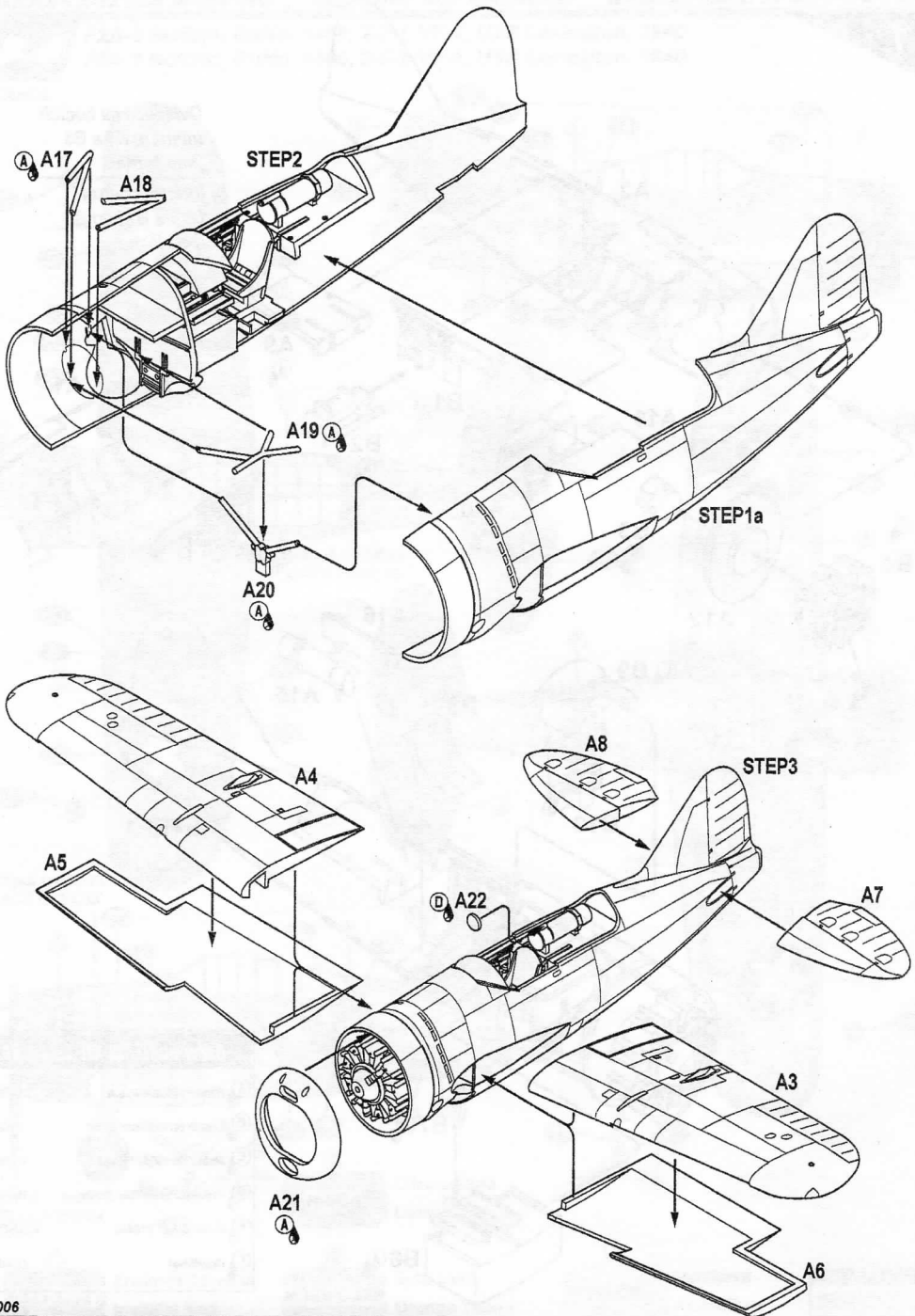

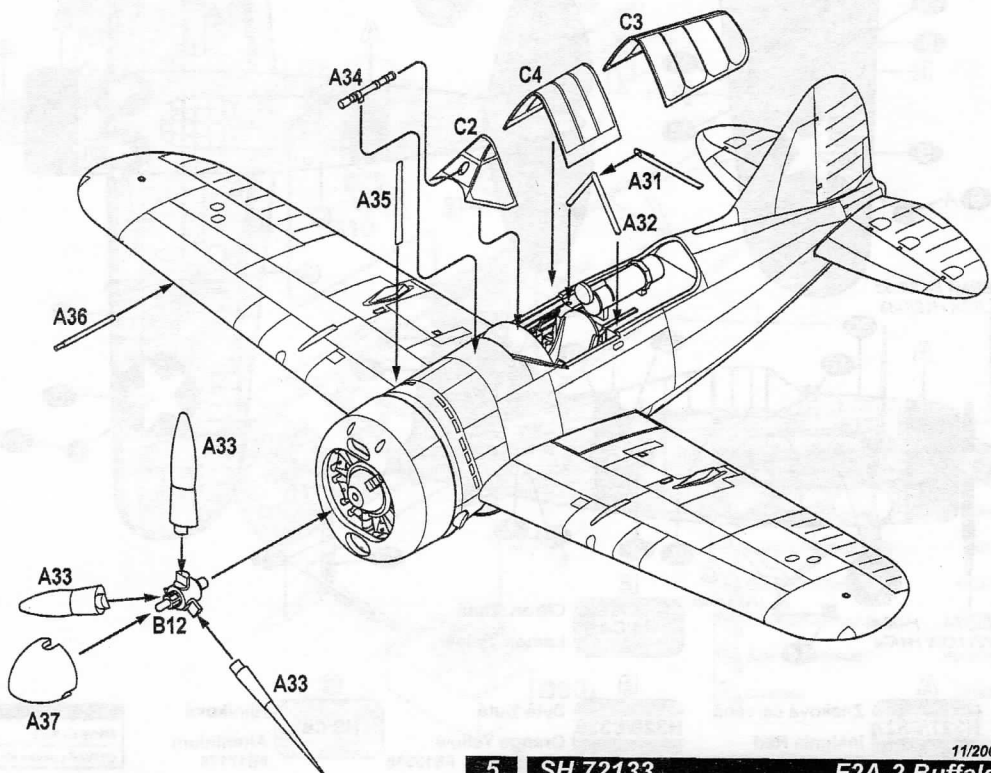
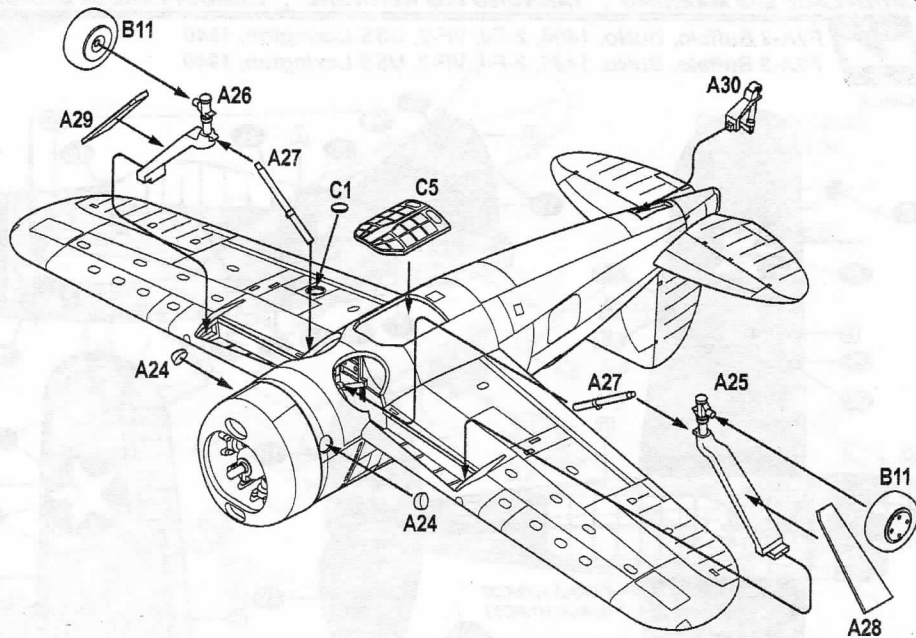

ZBARVENÍ a OZNAČOVÁNÍ

CAMOUFLAGE and MARKING, TARNUNG und KENNUNG, CAMOUFLAGE et DESIGNATION



F2A-2 Buffalo, BuNo. 1406, 2-F-1, VF-2, USS Lexington, 1940

F2A-2 Buffalo, BuNo. 1406, 2-F-1, VF-2, USS Lexington, 1940

Cam. A

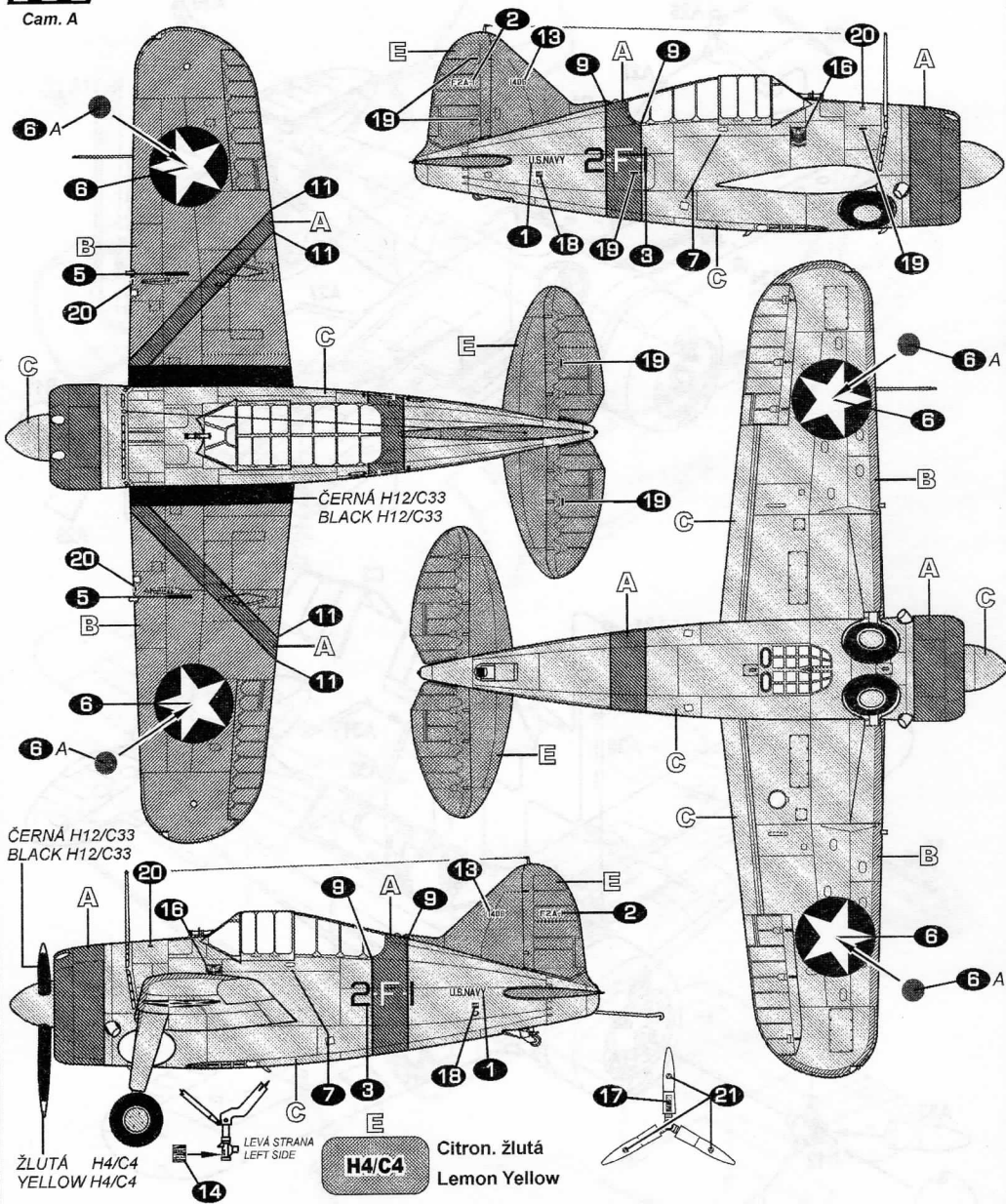

ČERNÁ H12/C33
BLACK H12/C33

ČERNÁ H12/C33
BLACK H12/C33

ŽLUTÁ H4/C4
YELLOW H4/C4

LEVÁ STRANA
LEFT SIDE

Citron. žlutá
Lemon Yellow

A
H327/C327 Znaková červená
Insignia Red
FS11136

B
H329/C329 Sytá žlutá
Orange Yellow
FS13538

C
H8/C8 Hliníková
Aluminium
FS17178

info
Barvy GUNZE
GUNZE colours No.

ZBARVENÍ a OZNAČOVÁNÍ

CAMOUFLAGE and MARKING, TARNUNG und KENNUNG, CAMOUFLAGE et DESIGNATION



F2A-2 Buffalo, BuNo. 1398, 3-F-8, VF-3, USS Saratoga, 1940

F2A-2 Buffalo, BuNo. 1398, 3-F-8, VF-3, USS Saratoga, 1940

Cam. B

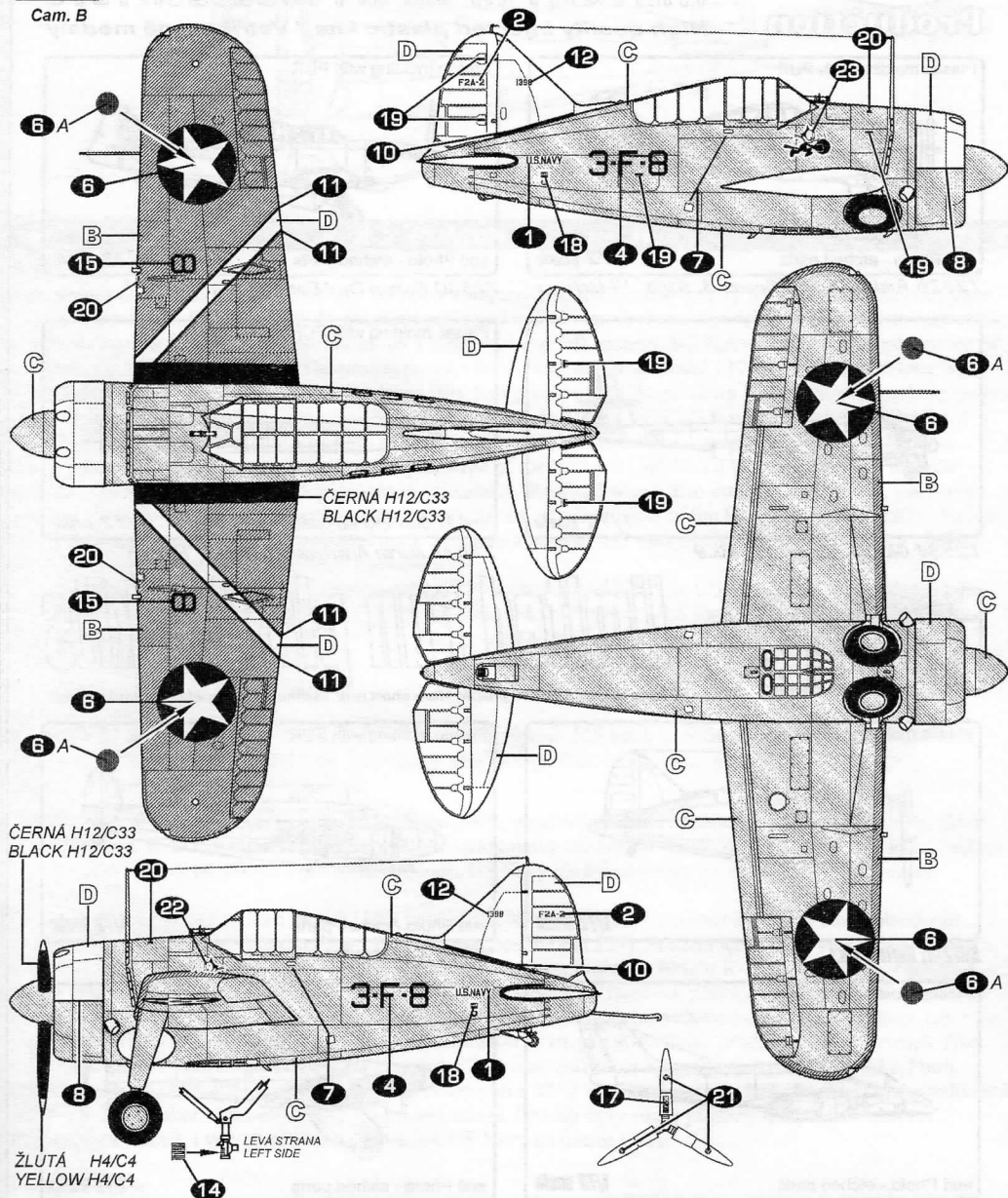

ČERNÁ H12/C33
BLACK H12/C33

ŽLUTÁ H4/C4
YELLOW H4/C4

B
H329/C329 Sytá žlutá
Orange Yellow
FS13538

C
H8/C8 Hliníková
Aluminium FS17178

D
H316/C316 Znaková bílá
Insignia White

info
Barvy GUNZE
GUNZE colours No.

Plastic molding with PUR

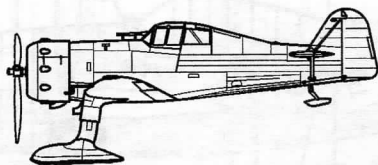

and Photo - etched parts *1/72 scale*
72526 Fokker D. XXI "Suomi 3. Sarja" "Hi-tech"

Plastic molding with PUR

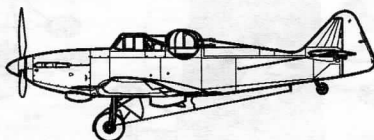

and Photo - etched parts *1/72 scale*
72530 Bolton Paul Defiant Mk. I "Hi-tech"

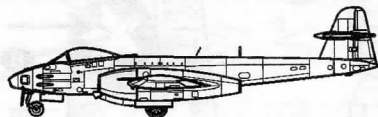

1/72 scale
72534 Gloster Meteor FR. Mk. 9

Plastic molding with PUR

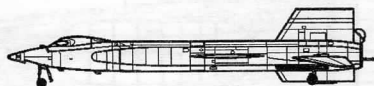

and Photo - etched parts *1/72 scale*
72537 North American X-15A-2 "Hi-tech"

Special
HOBBY

limited run plastic kits

High quality injected plastic kits - short run / Vstřikované modely - limitovaná série

Plastic molding with PUR

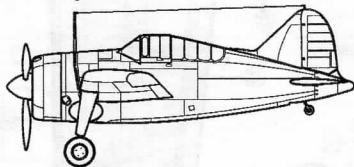

1/72 scale
SH72131 Buffalo Mk. I

Plastic molding with PUR

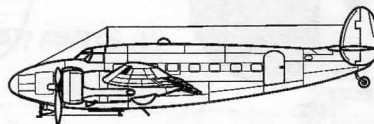

and Photo - etched parts *1/72 scale*
SH72112 C-50 Lodestar

Plastic molding with PUR

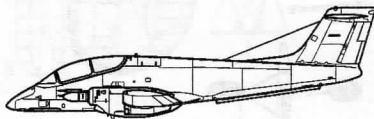

and Photo - etched parts *1/72 scale*
SH72047 IA.58A Pucará

Plastic molding with PUR

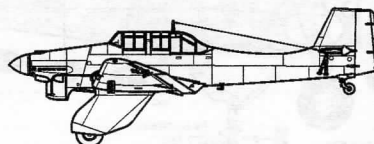

and Photo - etched parts *1/72 scale*
SH72123 Junkers Ju 87A Stuka