

P-47D, F-47D & F-47N Thunderbolt around the world

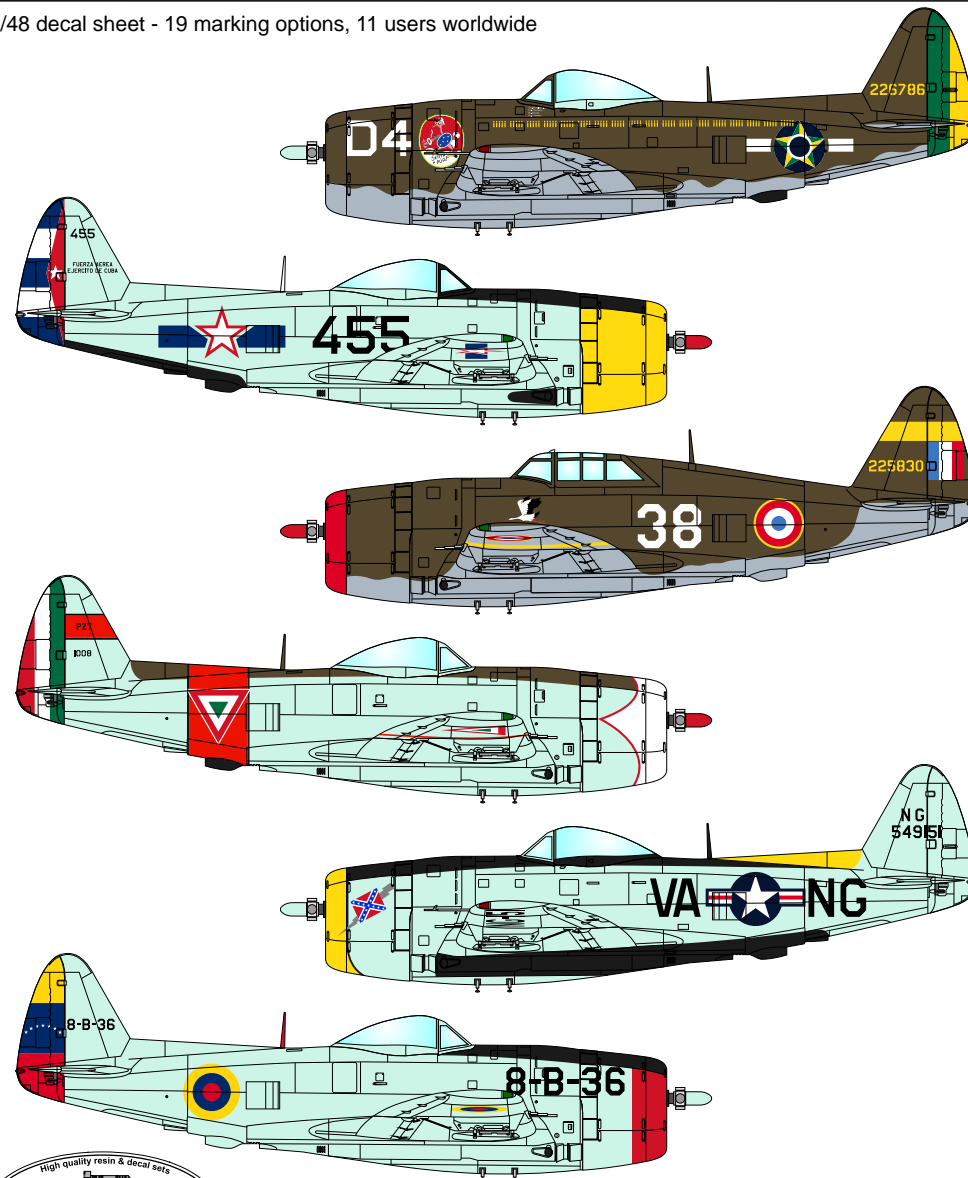

1/48 decal sheet - 19 marking options, 11 users worldwide

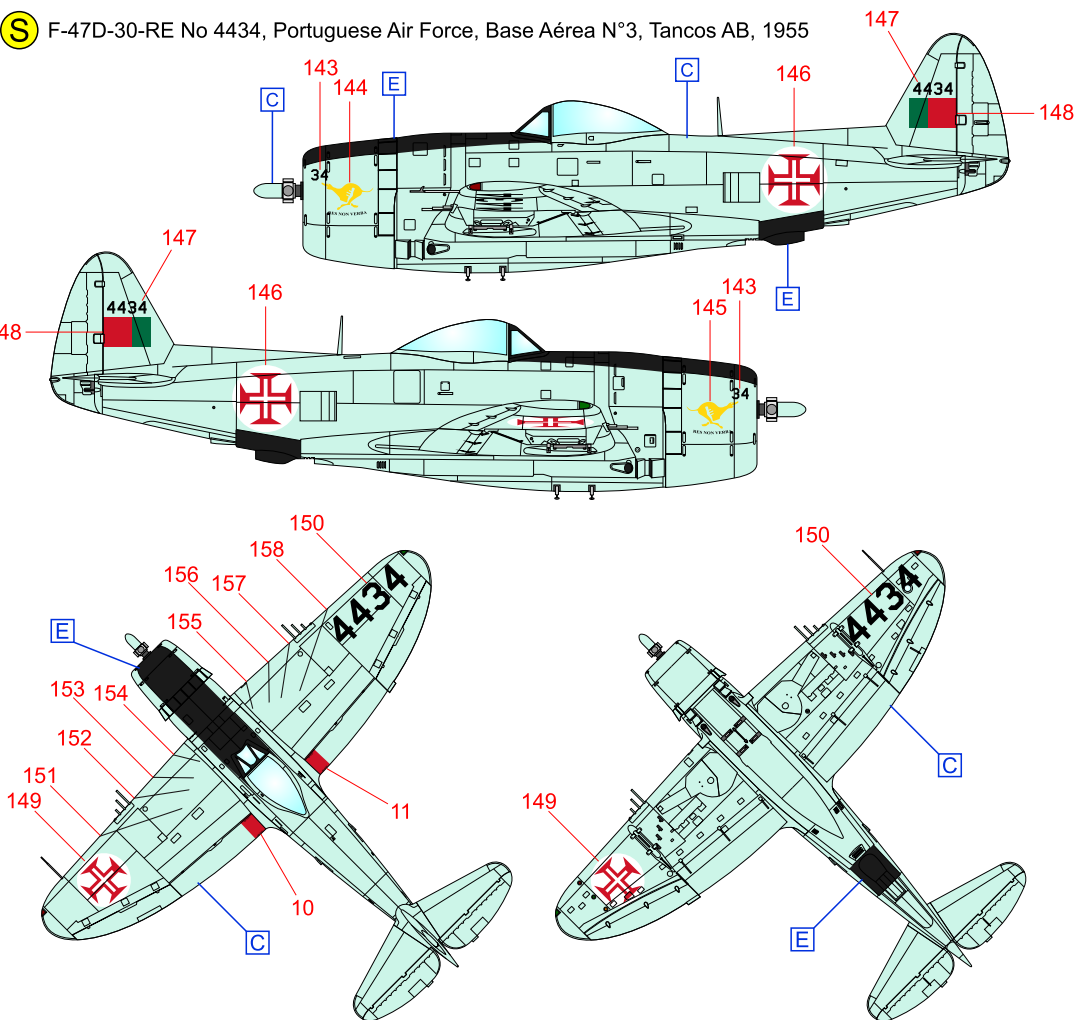

Recommended colours:

GUNZE SANGYO		Mr. COLOR	
A	OLIVE DRAB	FS 34087	304
B	NEUTRAL GREY	FS 36293	31
C	NATURAL ALUMINIUM		SM 01
D	RED	FS 11136	3
E	BLACK MATT	FS 37038	33
F	YELLOW	FS 23538	4

G	FADED OLIVE DRAB		
H	GREEN		6
I	WHITE	FS 17875	1
J	ORANGE		59
K	STEEL		

Recommended kits:

- P-47D - Tamiya
- P-47N - Academy

More products you can see on our webpage:

www.armycast.cz

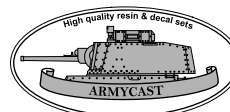

A P-47D-27-RE 42-26786, Brazilian Air Force, 1º Grupo de Aviação de Caça, Tarquinia Airport (Italy), February 1945
 (The plane was field upgraded with dorsal fillet assembly.)

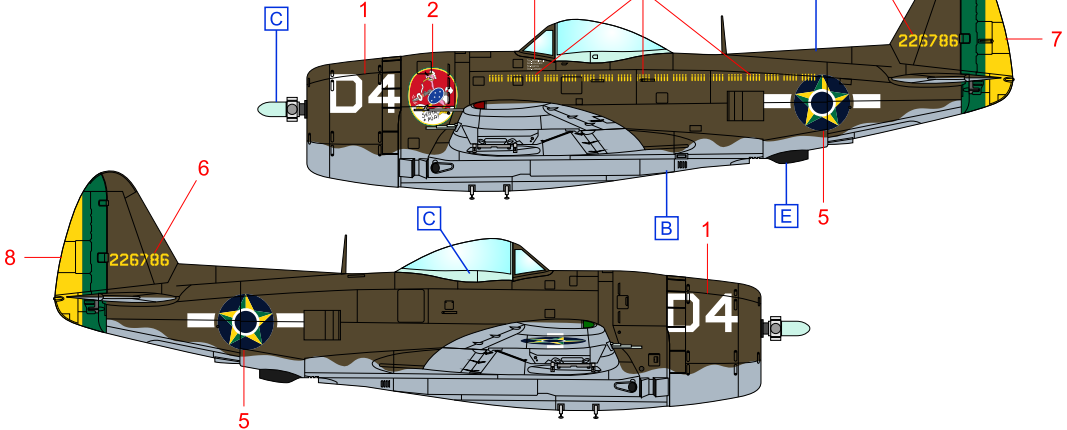

P

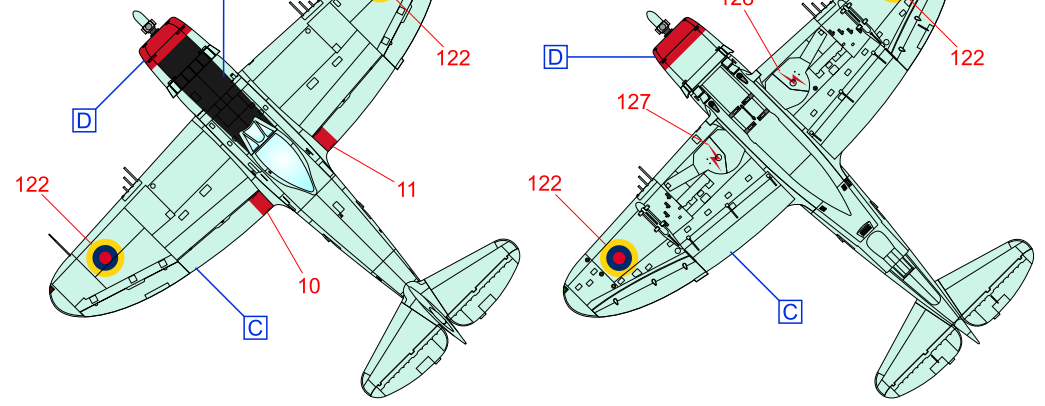

B P-47D-35-RE 44-20850, Brazilian Air Force, 1º Grupo de Aviação de Caça, Tarquinia Airport (Italy), 1945

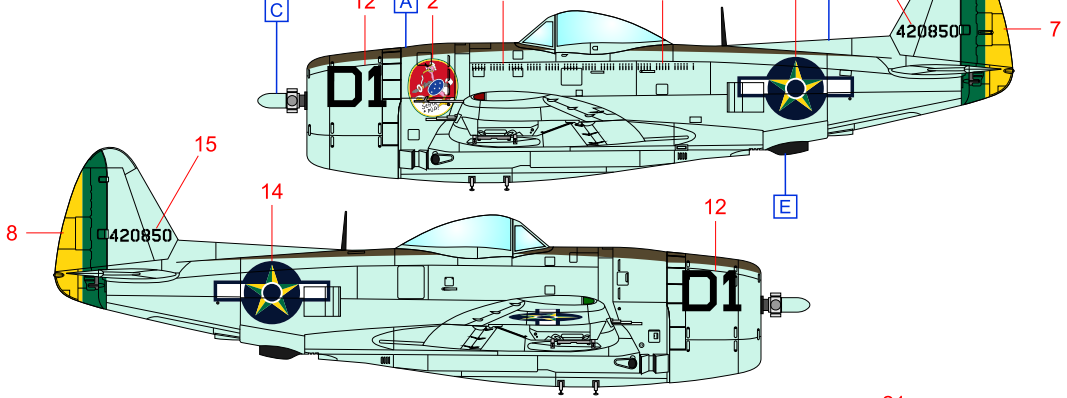

Q

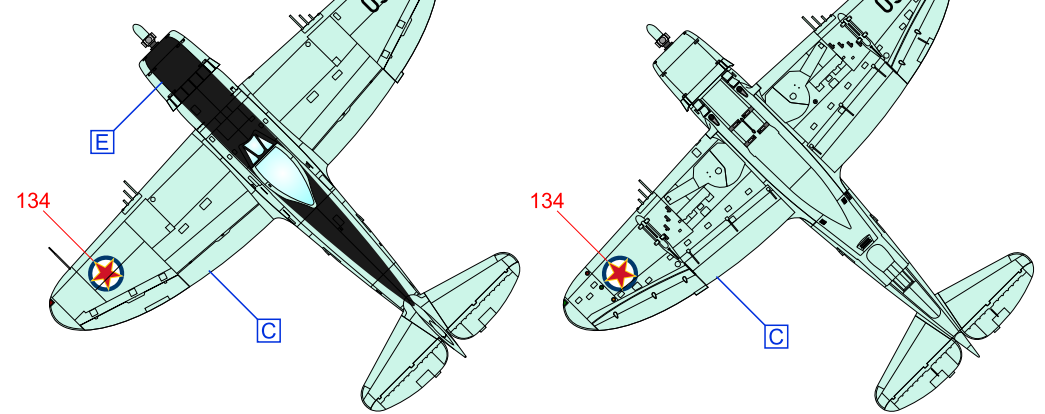

C F-47D-35-RA No 455 (s/n 44-90270), Cuban Air Force, Escuadrón de Combate, Campo Columbia AB, the 1950s

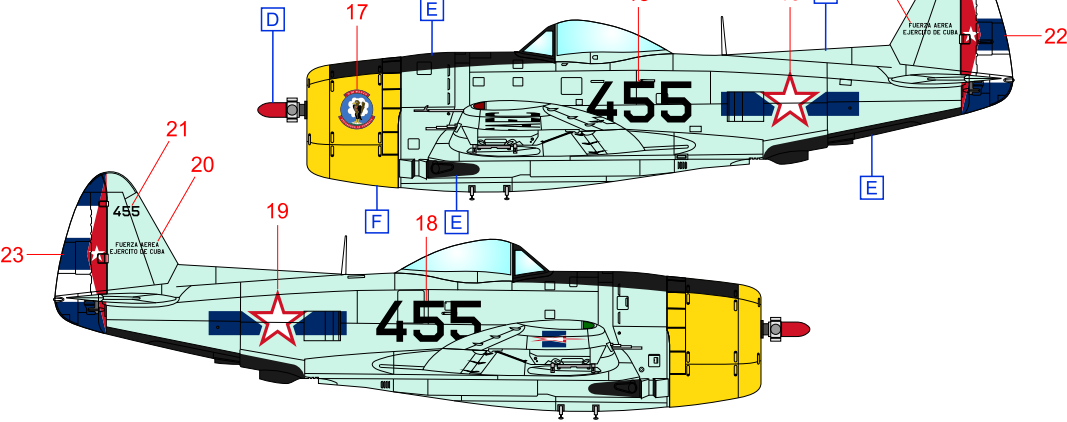

R

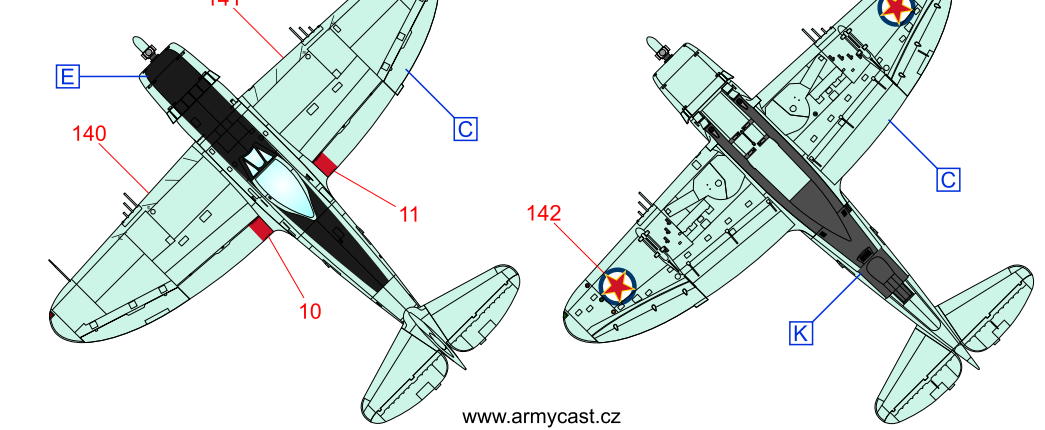

M

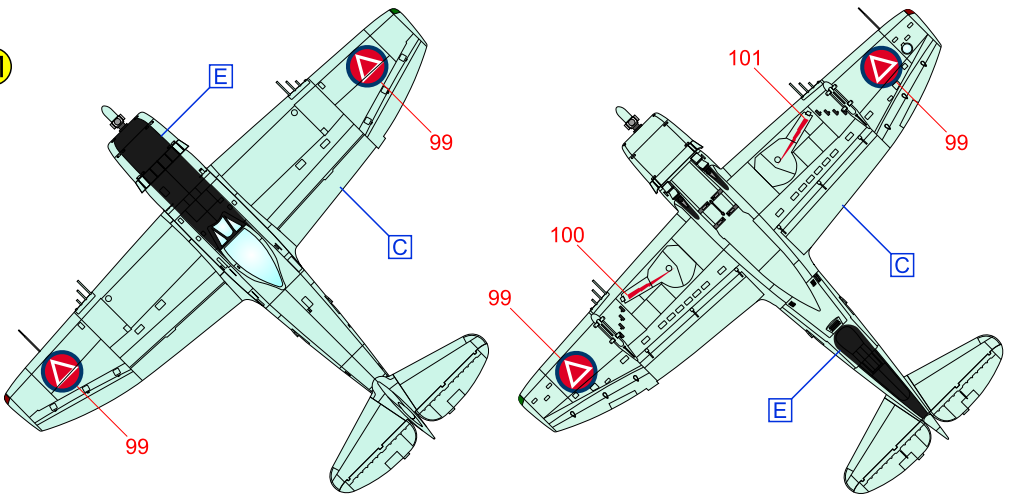

N

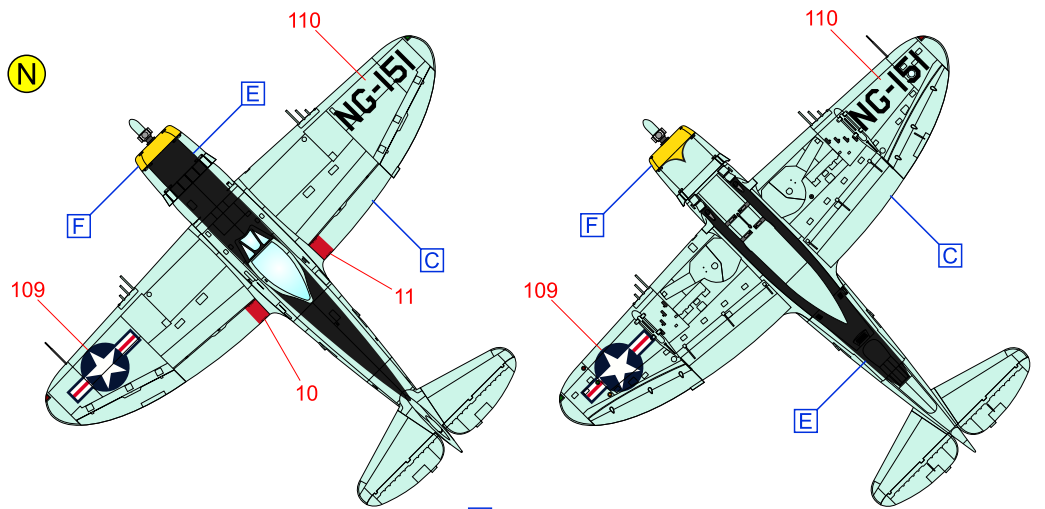

O

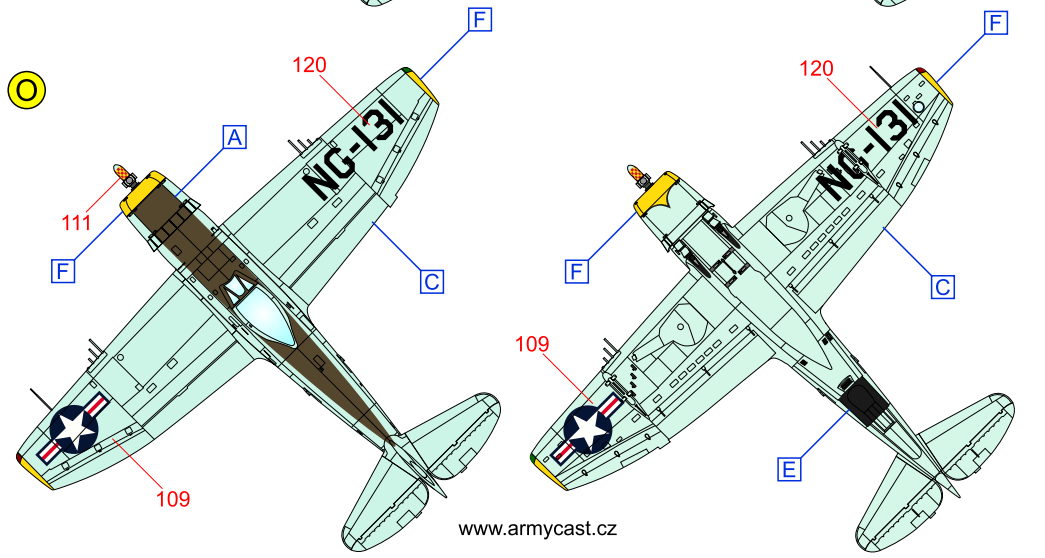

D

P-47D-35-RA No 1124, Dominican Air Force, Escuadron Caza-Bombarderos, Santiago Cibao International Airport, 1954

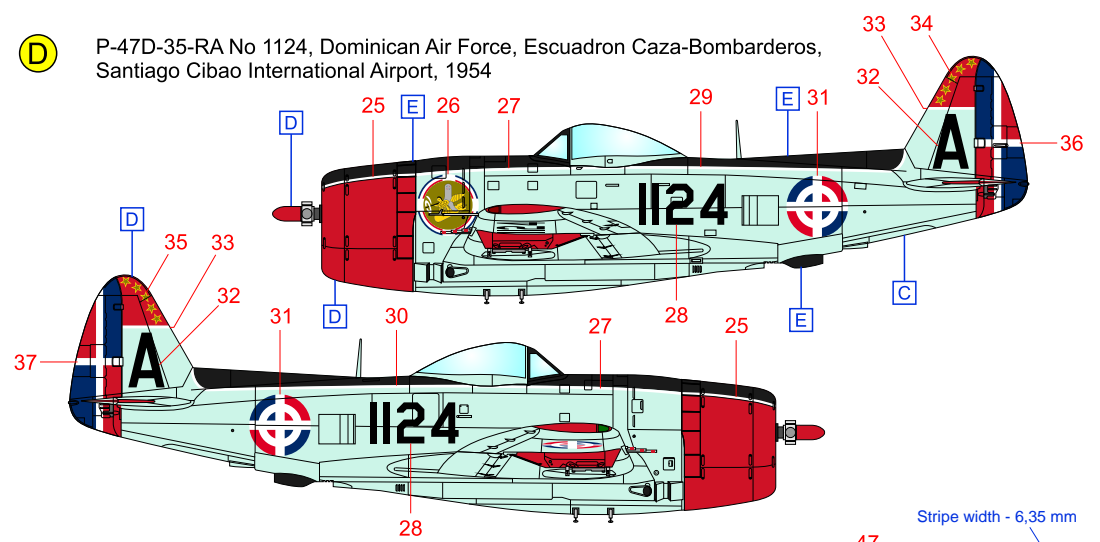

E

P-47D-22-RE 42-25830, Free French Air Force, GC II/5 „La Fayette”, Alto airfield (Corsica), June 1944

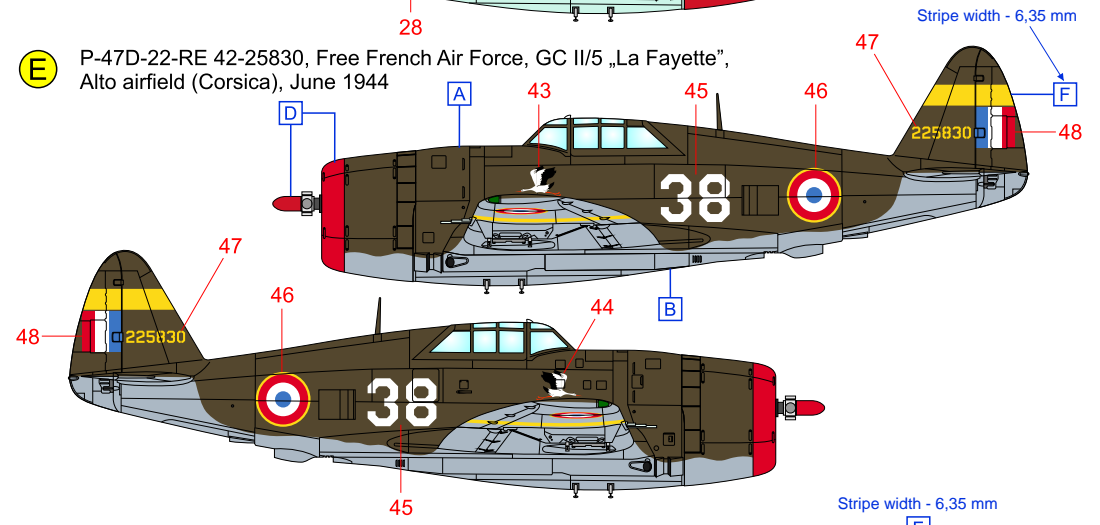

F

P-47D-26-RA 42-28363, Free French Air Force, Fighter Pilots Training Centre, Meknes AB (Morocco), 1945
This plane had been flown by Czech pilot of the Free French AF Lt. Lubomir Úleha.

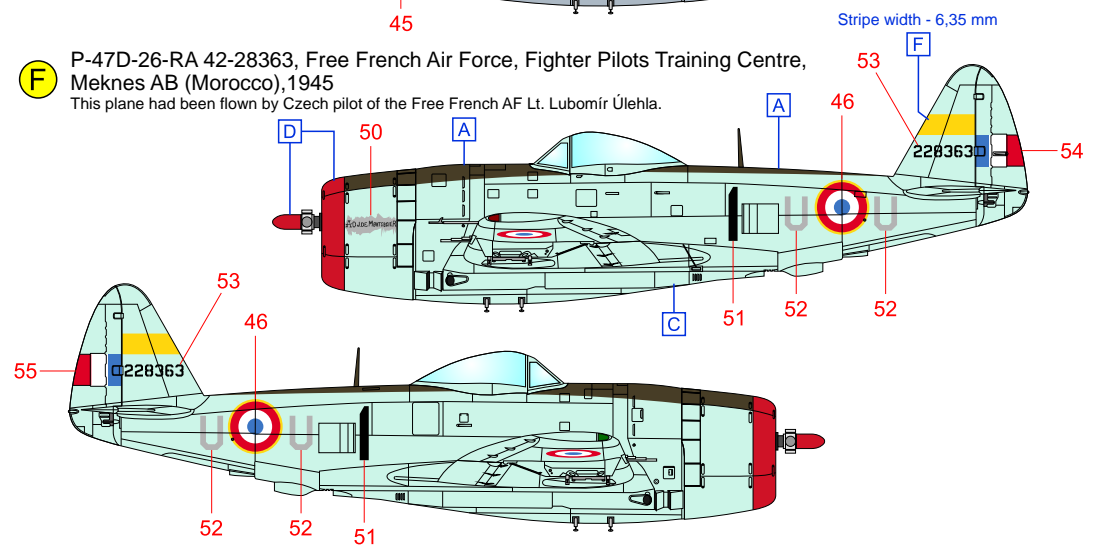

G P-47D-28-RE 44-20021, Free French Air Force, GC III/3 „Ardennes”, Luxeuil AB, April 1945

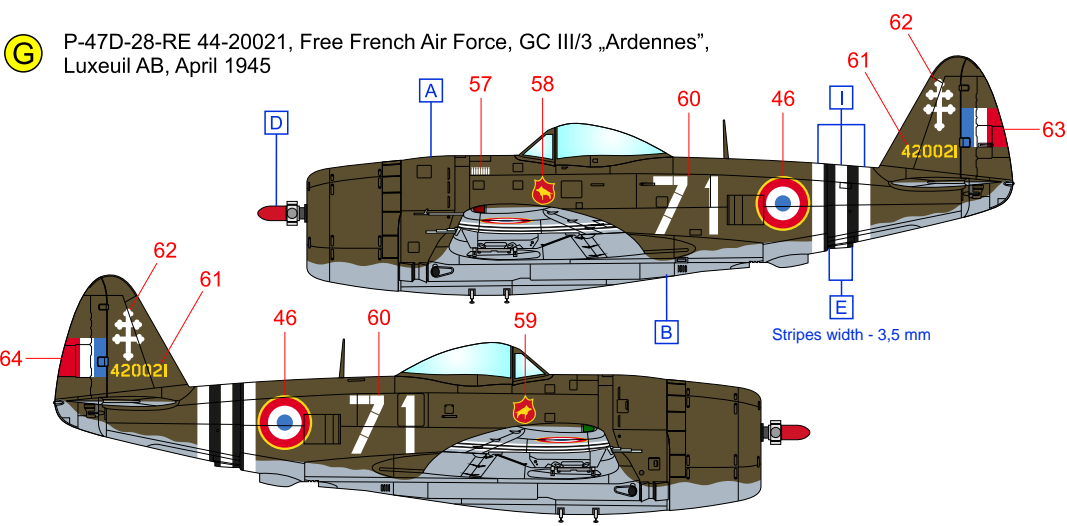

J

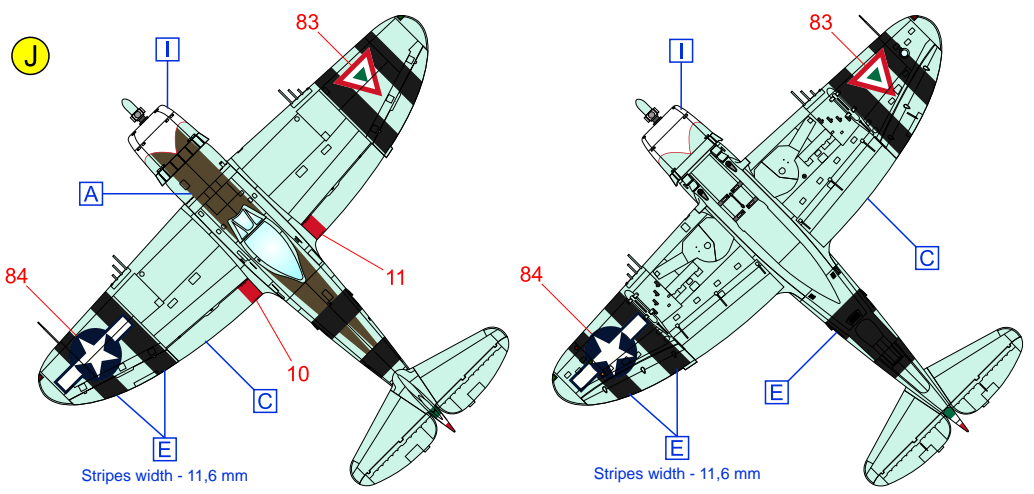

H P-47D-30-RA No. 2-60, Imperial Iranian Air Force, 1949

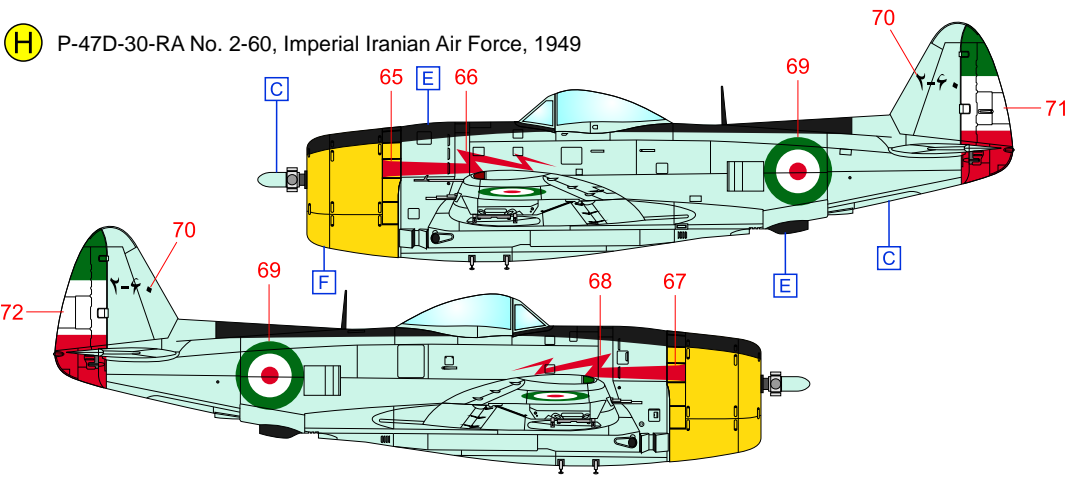

K

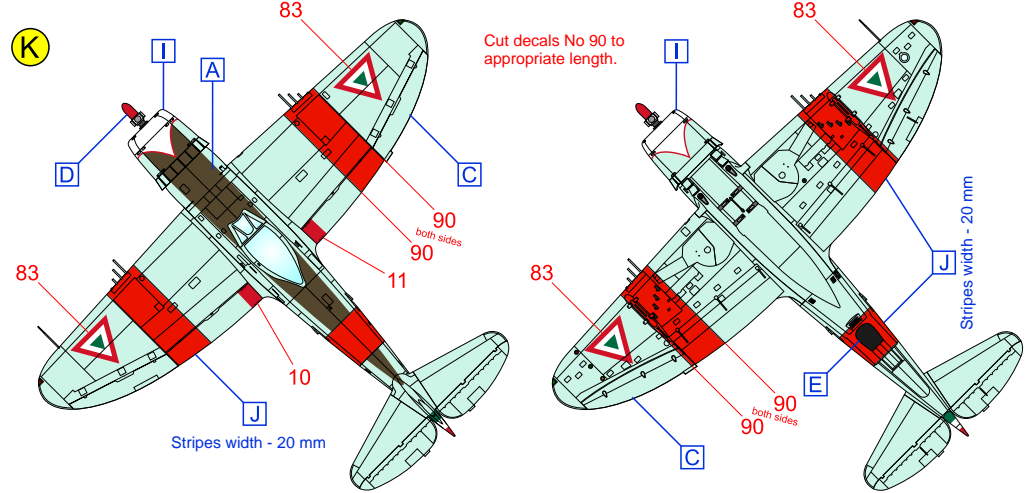

I P-47D-30-RA No. 2-85 (s/n 44-33129), Imperial Iranian Air Force, 1949

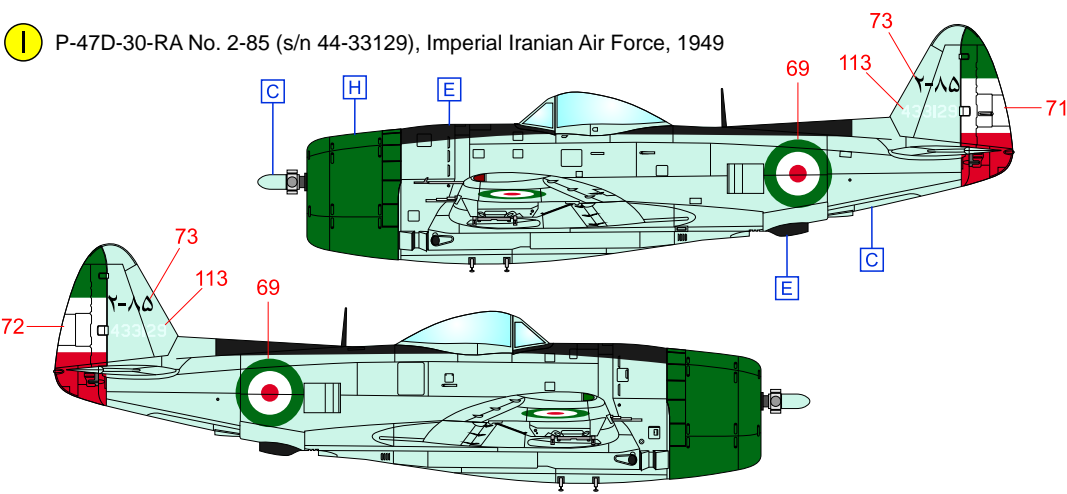

L

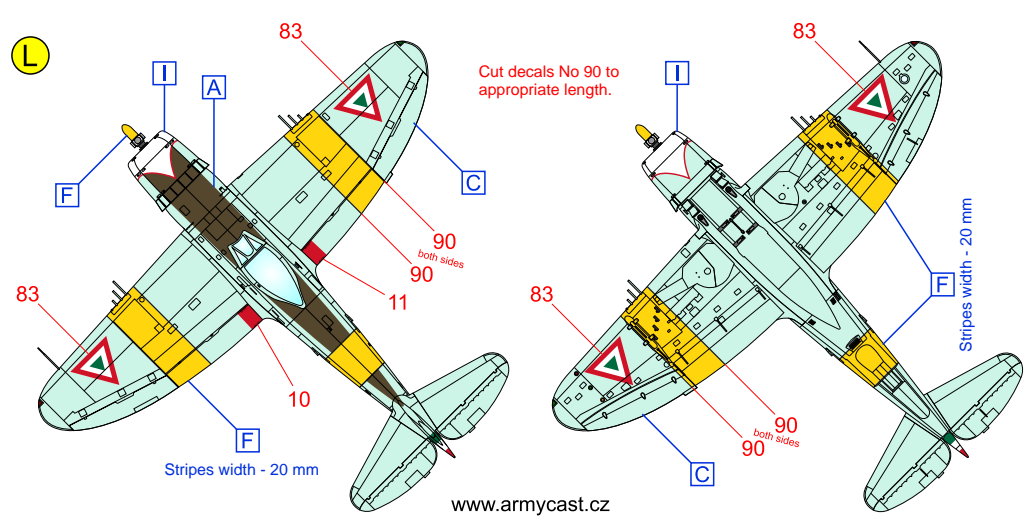

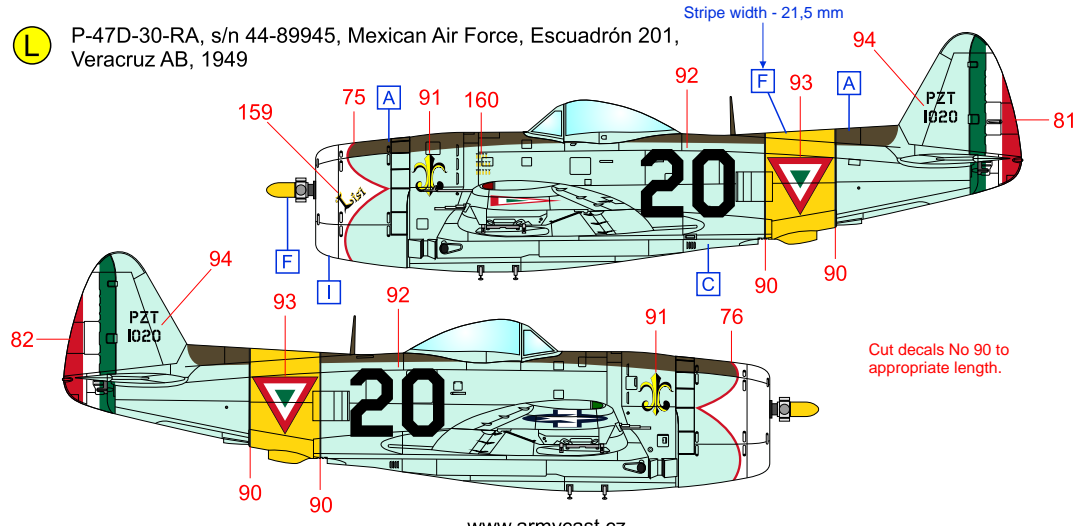
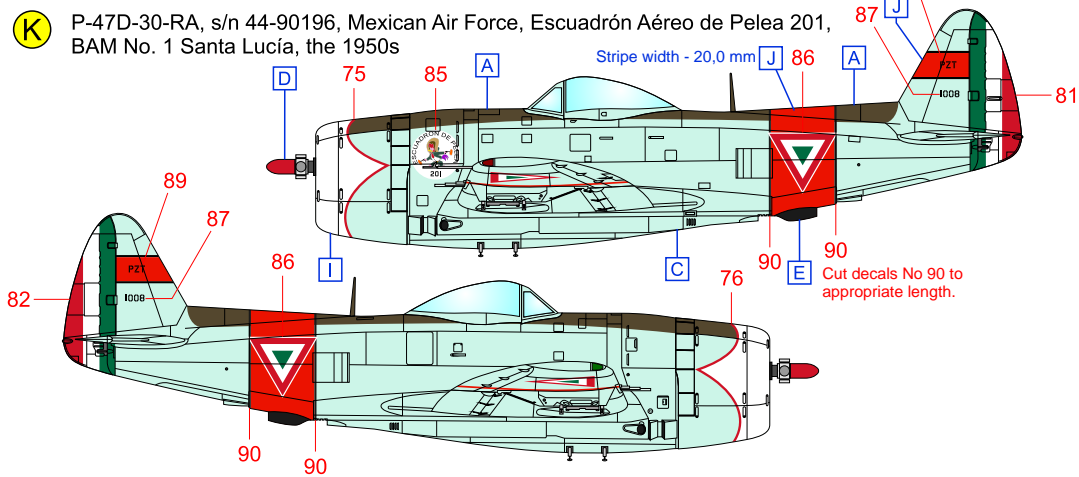
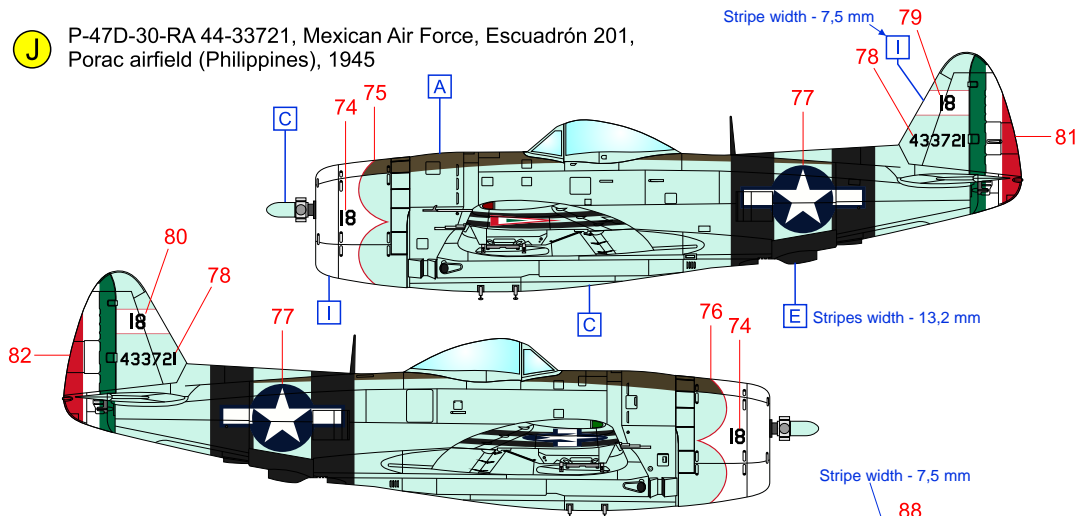
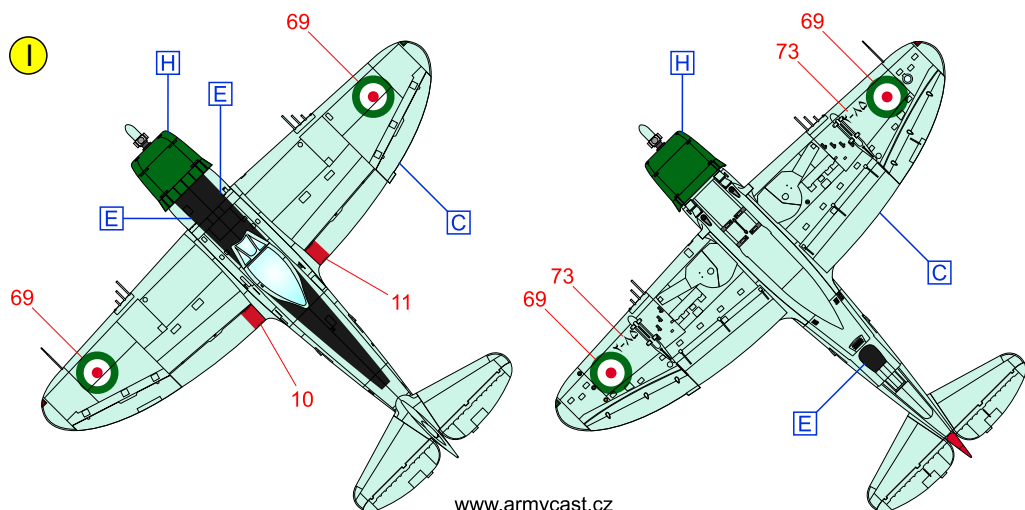
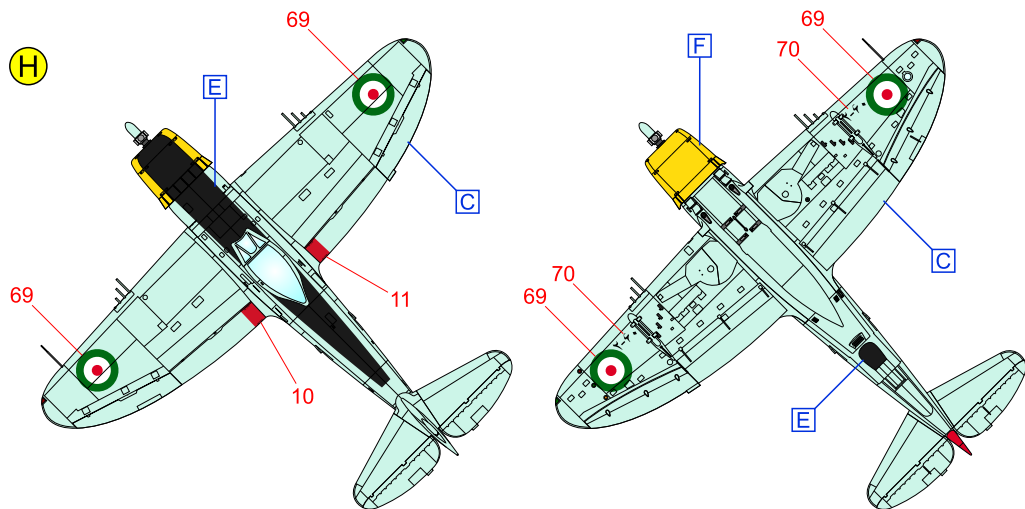
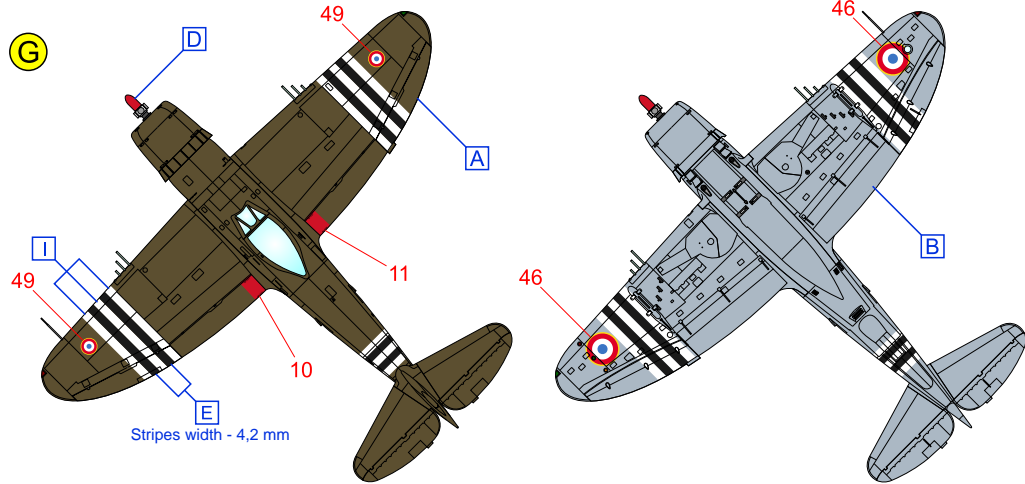

M F-47N-25-RE No 71 (s/n 44-89439), Nicaraguan Air Force, Escuadrón de Combate, Las Mercedes AB, mid 1950s

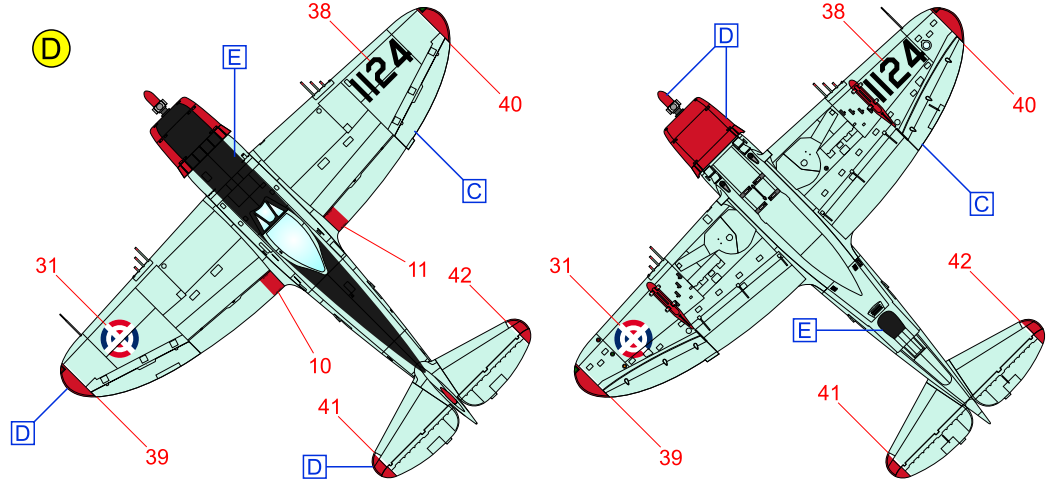
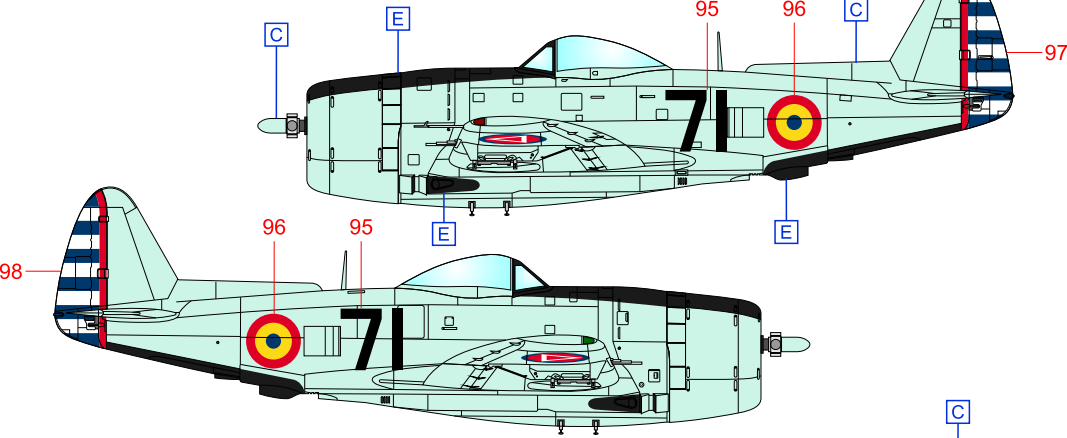

N F-47D-40-RA, s/n 45-49151, United States, Virginia Air National Guard, 149th Fighter Squadron, Byrd Field, 1950

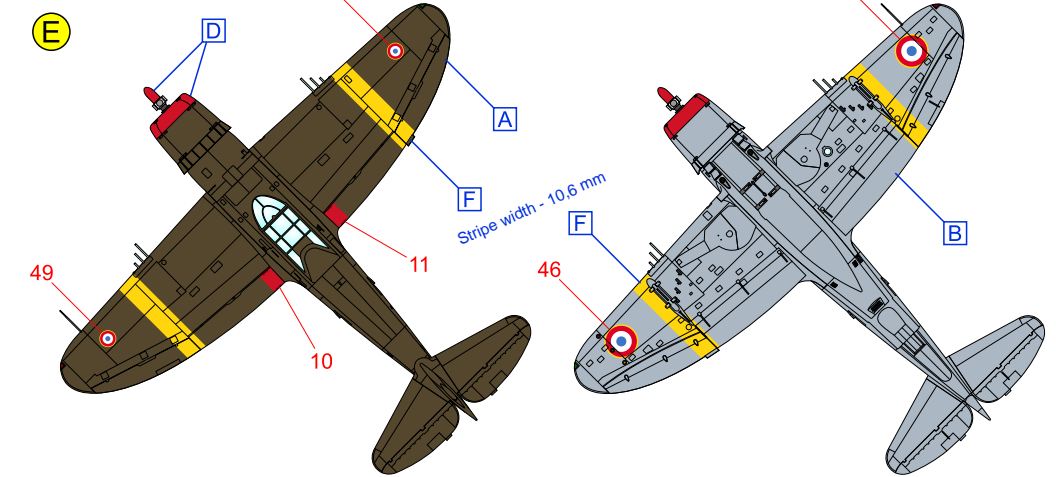
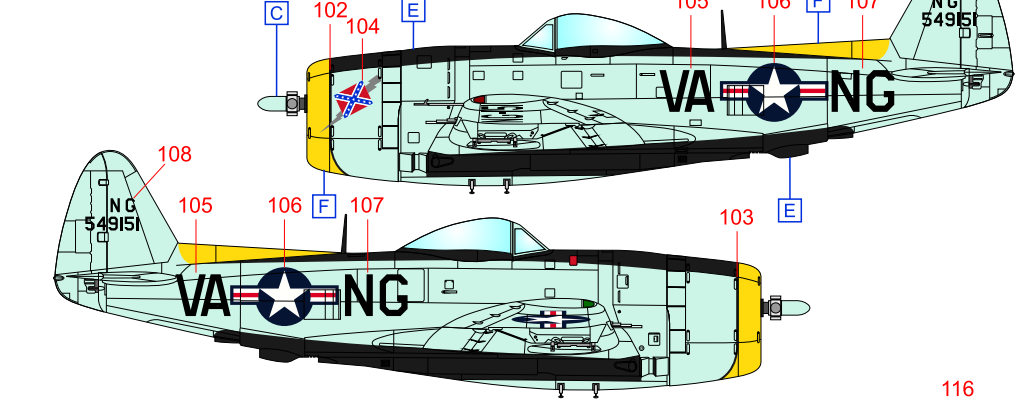

O F-47N-20-RE, s/n 44-89131, United States, Pennsylvania Air National Guard, 146th Fighter Squadron, Greater Pittsburgh Airport, late 1940s

