

MIG-29UB FULCRUM

ESCALA 1:48
KIT 02119

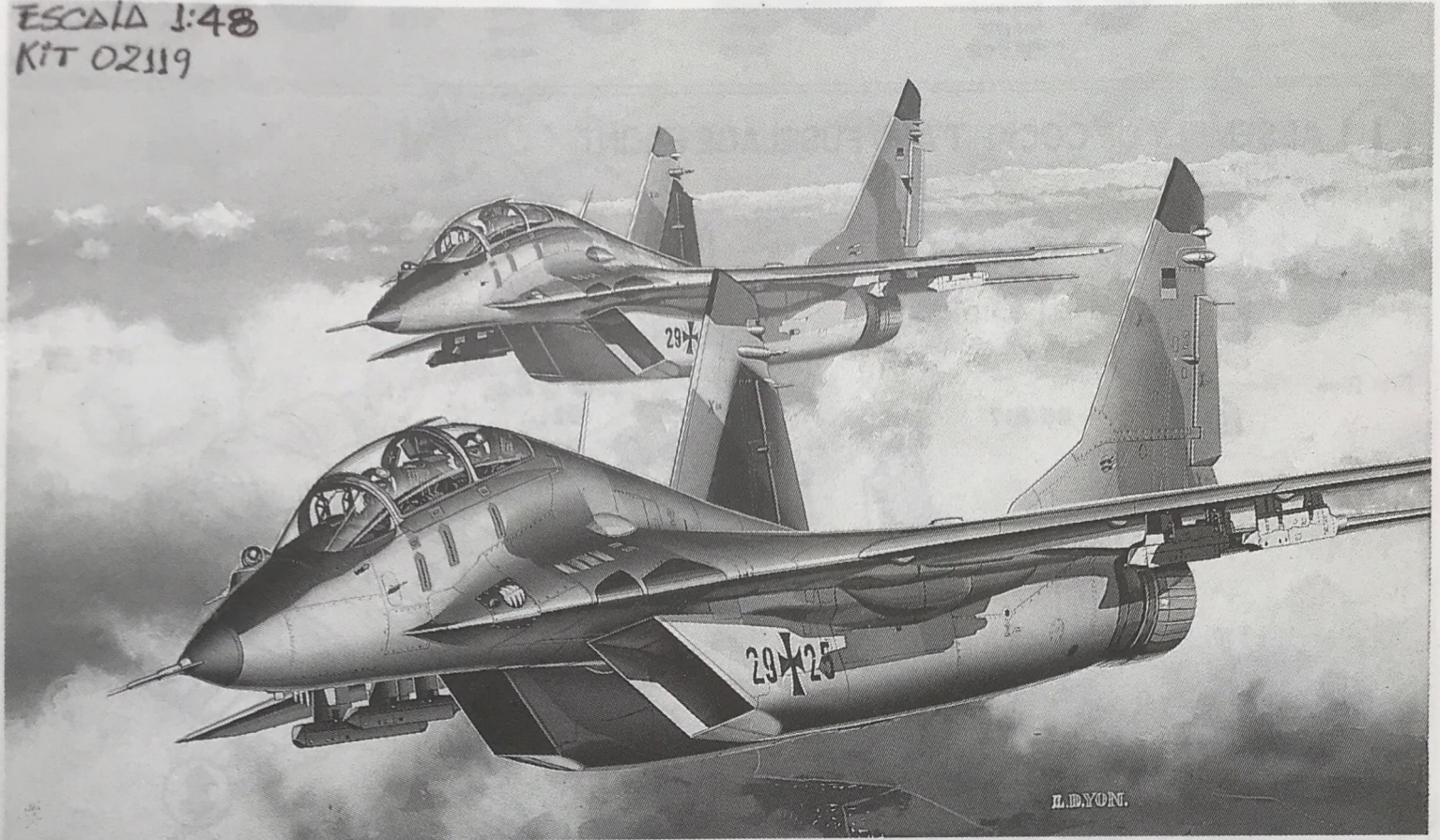

Flown by the former member nations of the USSR plus India, Syria, Iraq, Yugoslavia, Germany, Poland, Romania, Bulgaria, North Korea, the Czech Republic, Slovakia and Cuba the **MIG-29UB** is not only a two-seat trainer, but is fully combat effective as well.

The two-seat version does not carry the chaff dispensers or the pulse Doppler radar found on the single seat fighters, but otherwise is fully armed and equipped with a full compliment of combat avionics. Generally, each squadron of **MIG-29** fighters has two to four trainer versions for pilot and/or combat weapons training. The instructor sits in the rear, elevated ejection seat for pilot training, evaluation or weapons proficiency rating.

Designed at the same time as the **MIG-29A**, it is estimated that over 250 of the two-seat versions have been built and entered operational status. Well over 1,000 **MIG-29's** of all types have been manufactured and are still being made to this day. Fully equal to the F-15 or F-18 in performance, the MIG has the added strength of its quick and easy maintenance. Five mechanics can remove, replace and test an engine under field conditions in less than one hour! In this day of super-sophisticated engineering, the simplicity of the MIG design ensures that it will be a very important combat airplane well into the 21st century.

This model depicts a late production version of the improved **MIG-29UB**. The kit has been engineered from highly detailed Russian drawings and many photographs taken both in Moscow and other countries when the **MIG-29s** made demonstration visits.

Copyright 1993 Academy Plastic Model Co., Ltd.

273-64, Suyu-dong, Kangbuk-ku, Seoul, Korea FAX: 82-2-997-3003

PARTS LOCATOR

A

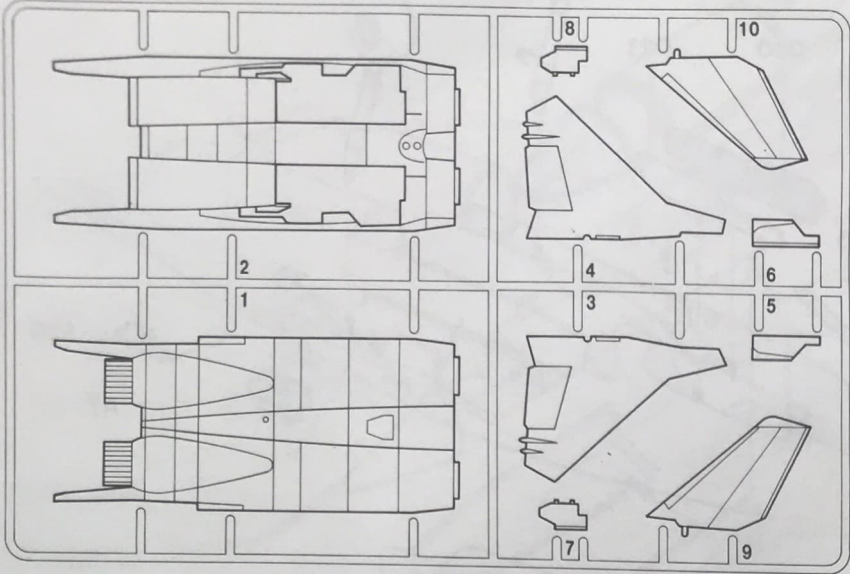

B

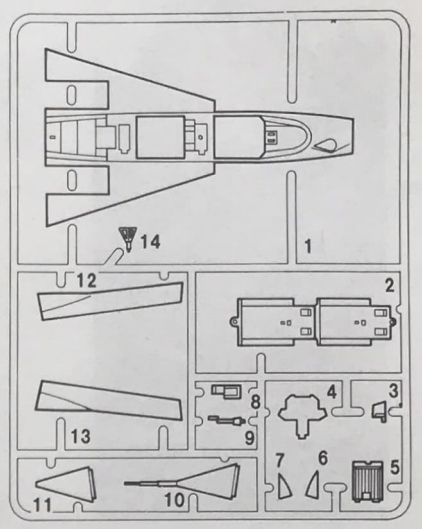

C

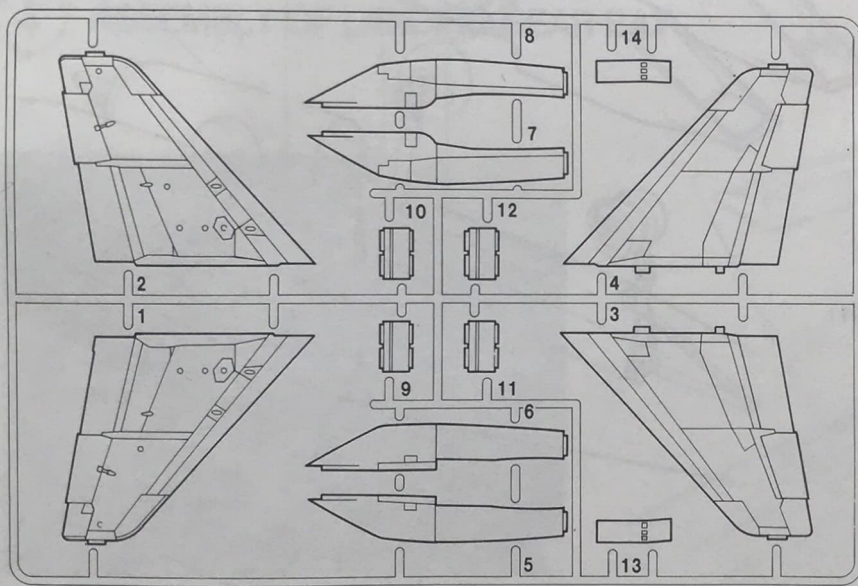

E

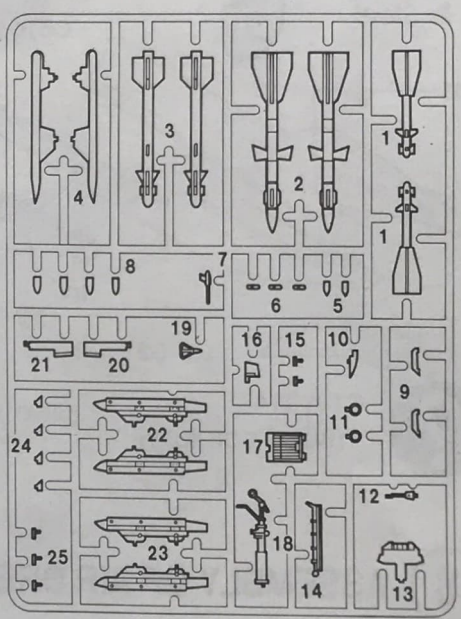

D

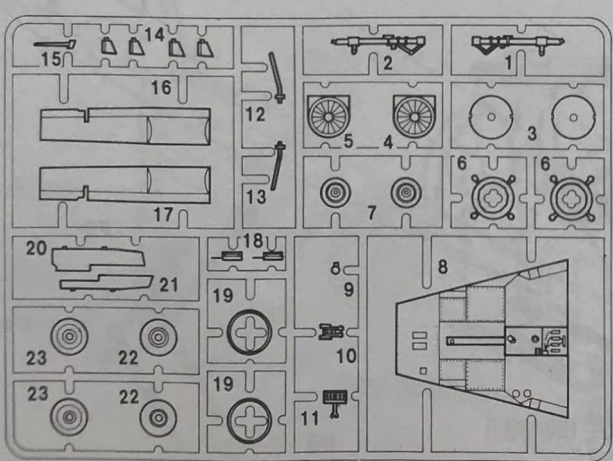

F

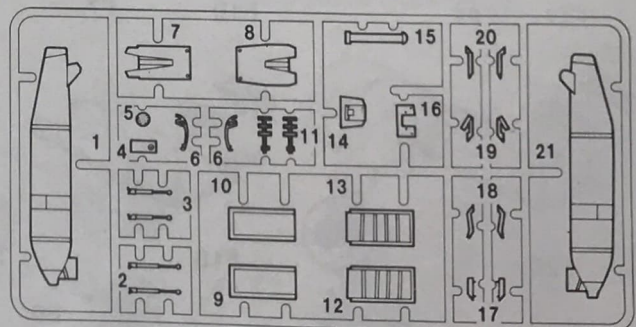

G

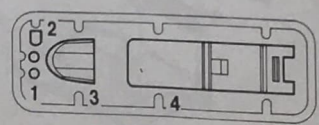



Cement Parts
 Coller
 Kleben
 Pegar
 Incollare
 Colar
 Kleven



DO NOT cement
 Ne pas coller
 Nicht kleben
 No pegar
 Non incollare
 Nao colar
 Niet kleven



Cut away
 Couper
 Scheiden
 Cortar
 Tagliare
 Cortar
 Snijden



Optional parts
 Choix
 Auswahlmöglichkeit
 Eleccion
 Sclta
 Opcao
 Keuze



3

Repeat operation
 Répéter l'opération
 Vorgang wiederholen
 Repetir la operación
 Ripetere
 Repetir a operação
 Herhalen

1 ASSEMBLY OF COCKPIT AND FUSELAGE FRONT

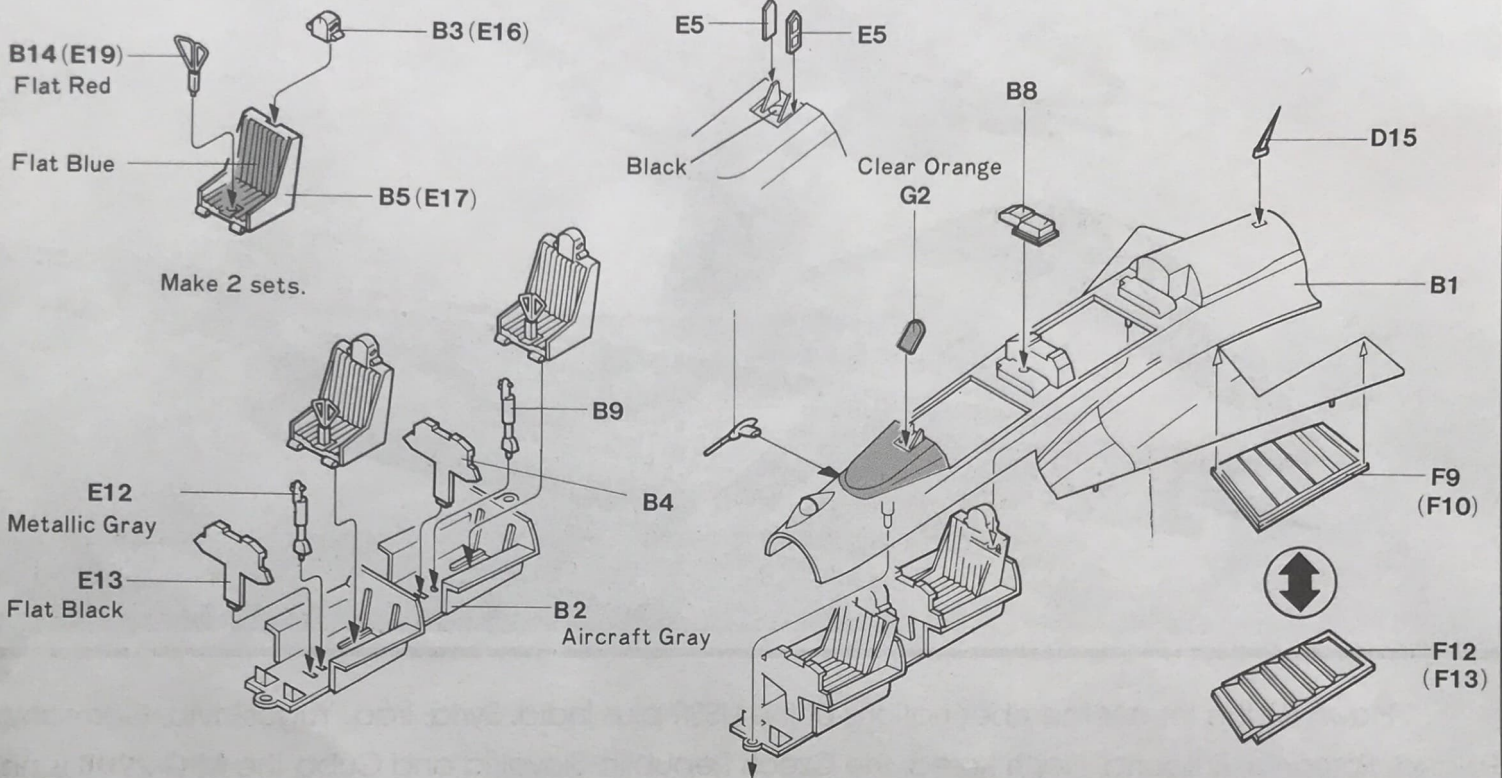

2 ASSEMBLY OF FUSELAGE

INTERIOR COLOR
 Grey (FS 36375)

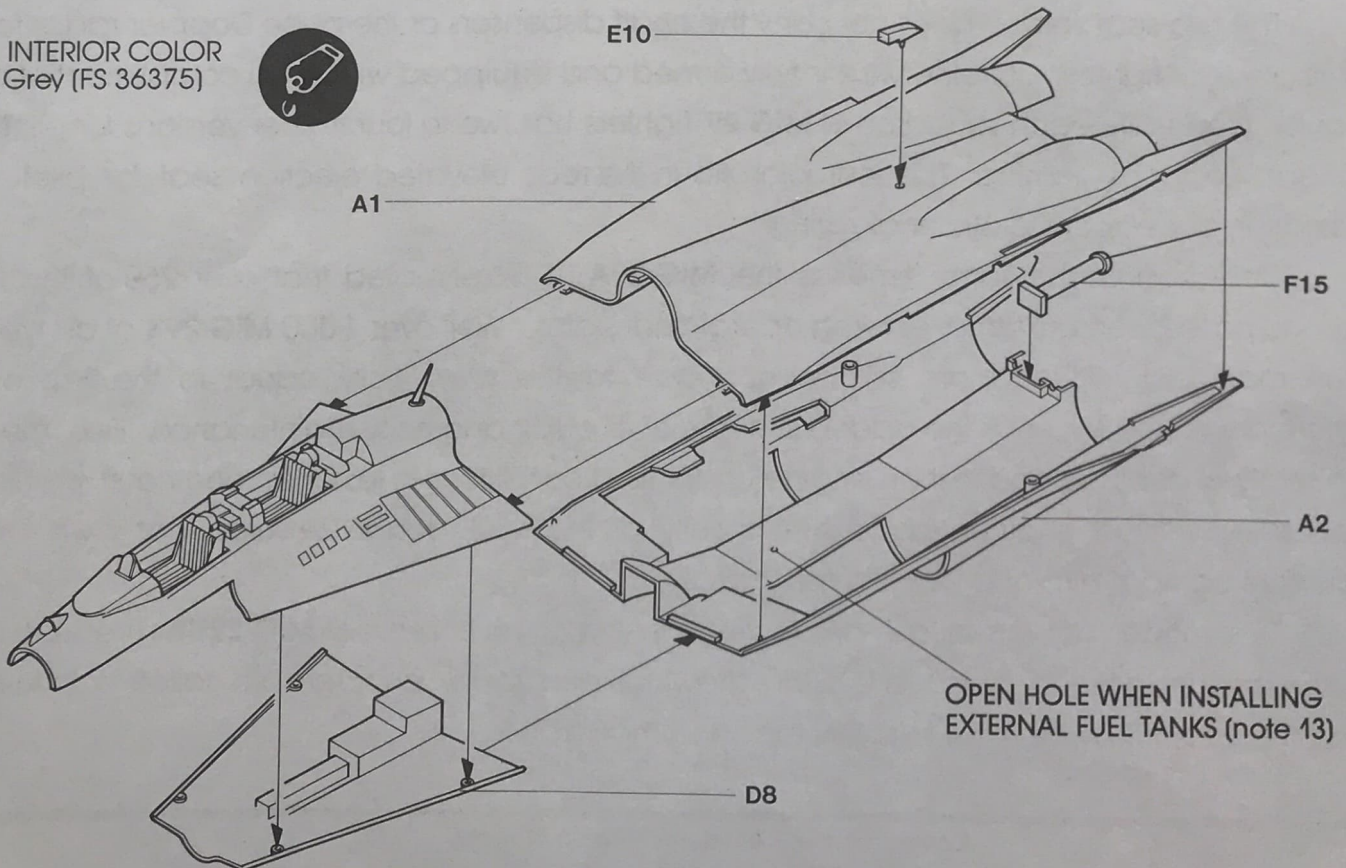

3 CANOPY INSTALLATION

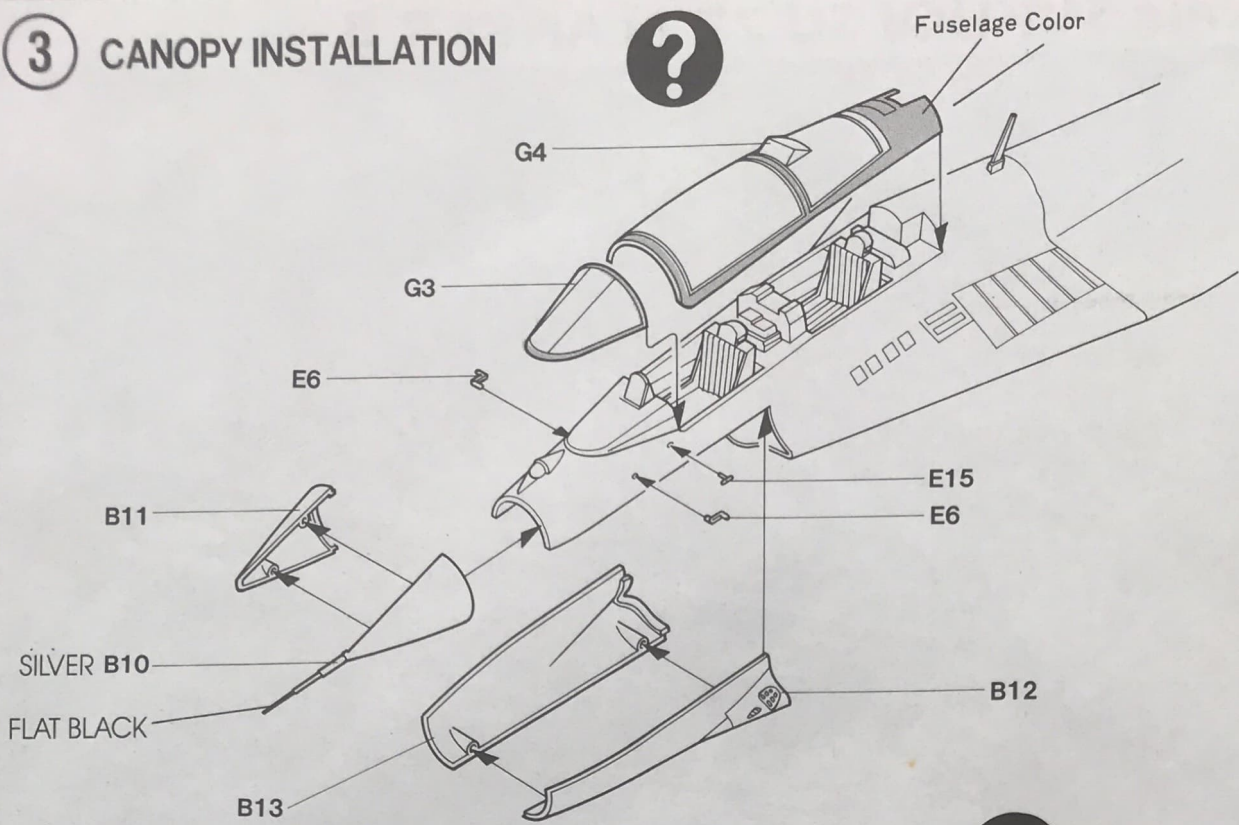

4 ASSEMBLY OF LANDING GEAR BAY

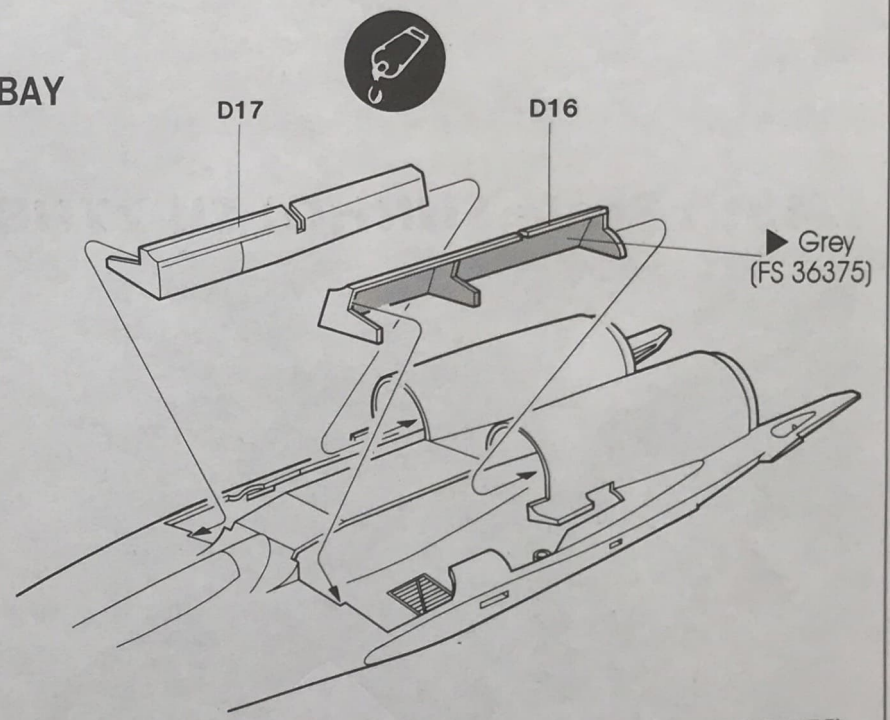

5 ASSEMBLY OF LANDING GEAR I

Landing Gear — Grey (FS 36375)
Wheel Hubs — Dark Green (FS 34226)

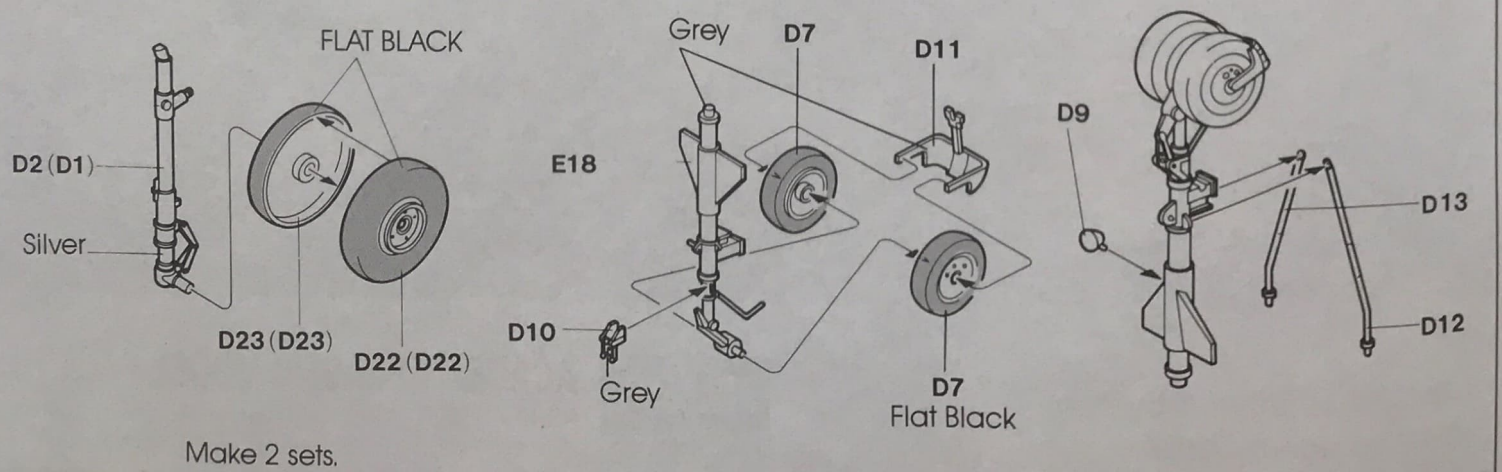

6 ASSEMBLY OF LANDING GEAR II

INTERIOR LANDING GEAR WHEELS
GREY (FS 36375)

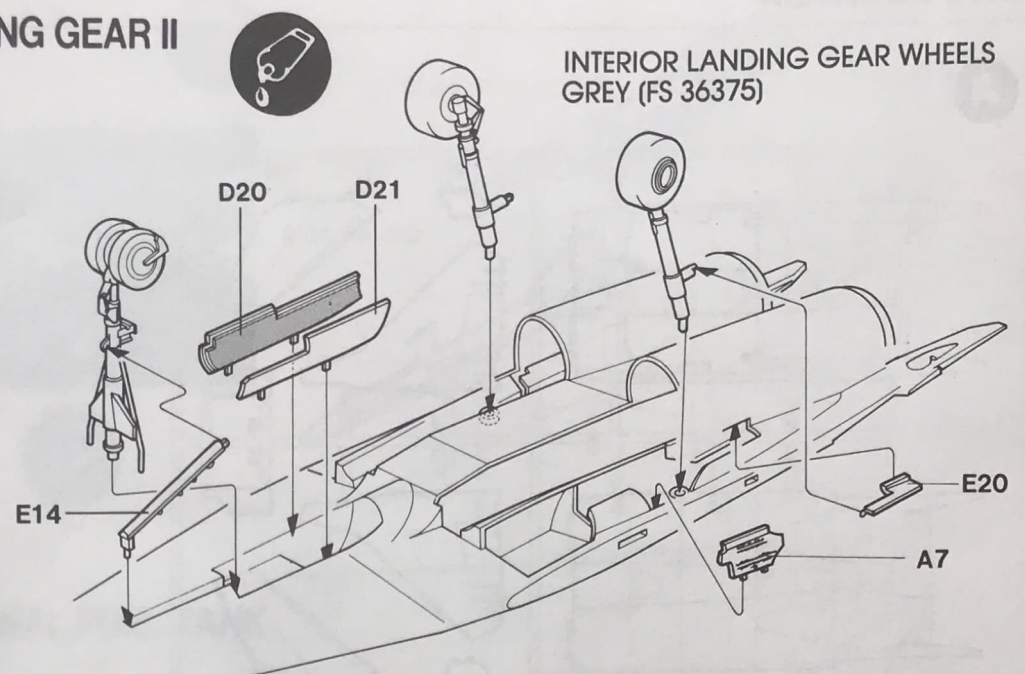
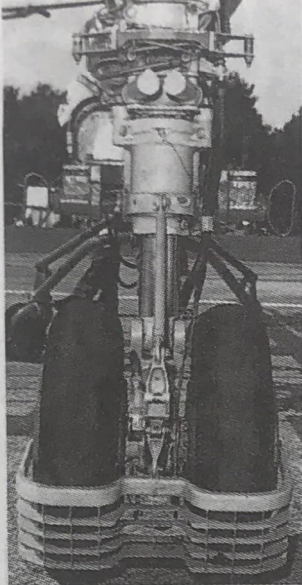

7 ASSEMBLY OF AIR INTAKE

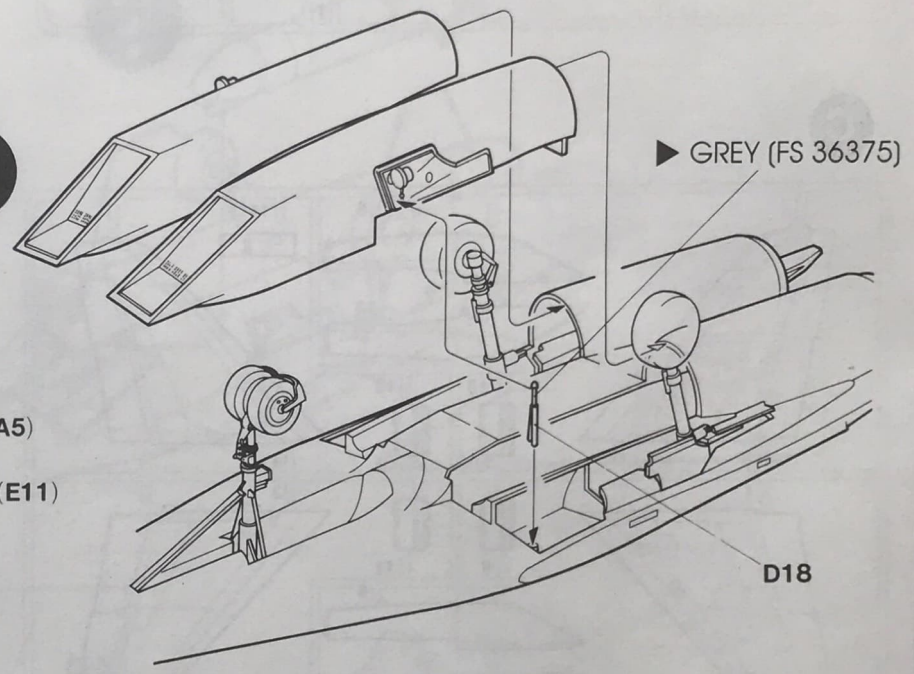
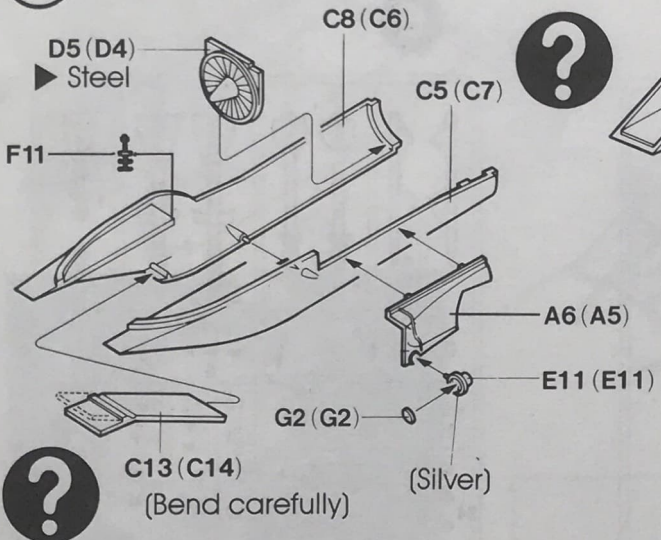

8 ASSEMBLY OF AIR BREAK

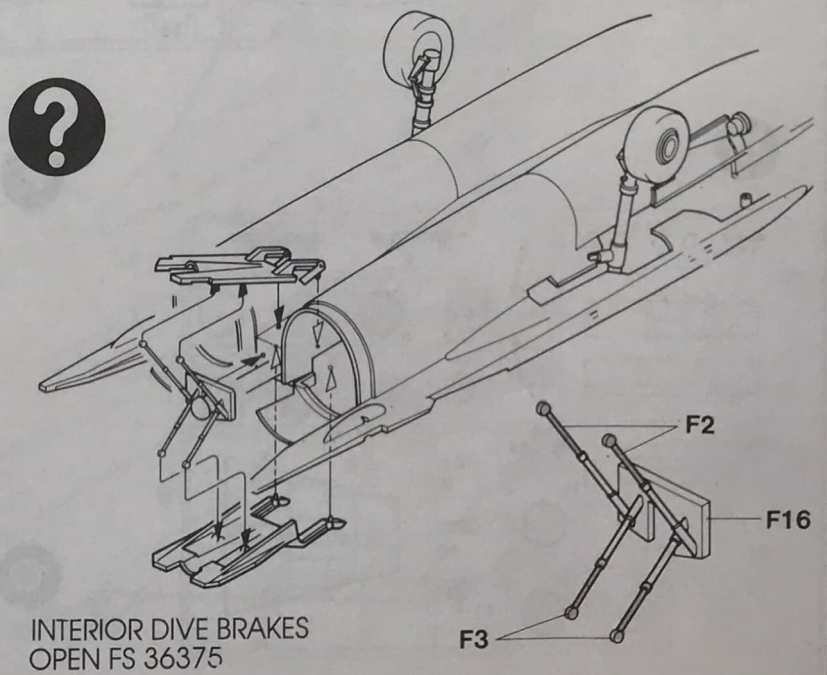
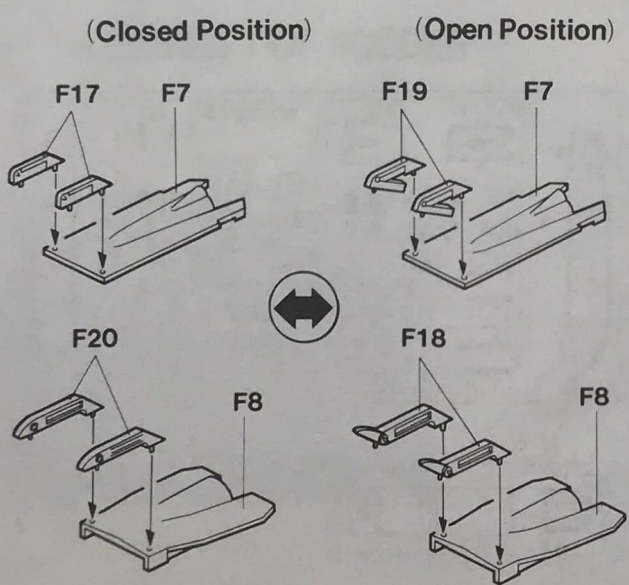

INTERIOR DIVE BRAKES
OPEN FS 36375

DO NOT ASSEMBLE WHEN IN CLOSED POSITION

9 ASSEMBLY OF EXHAUST CONE

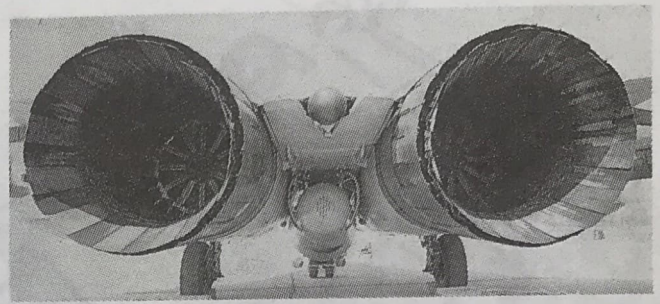
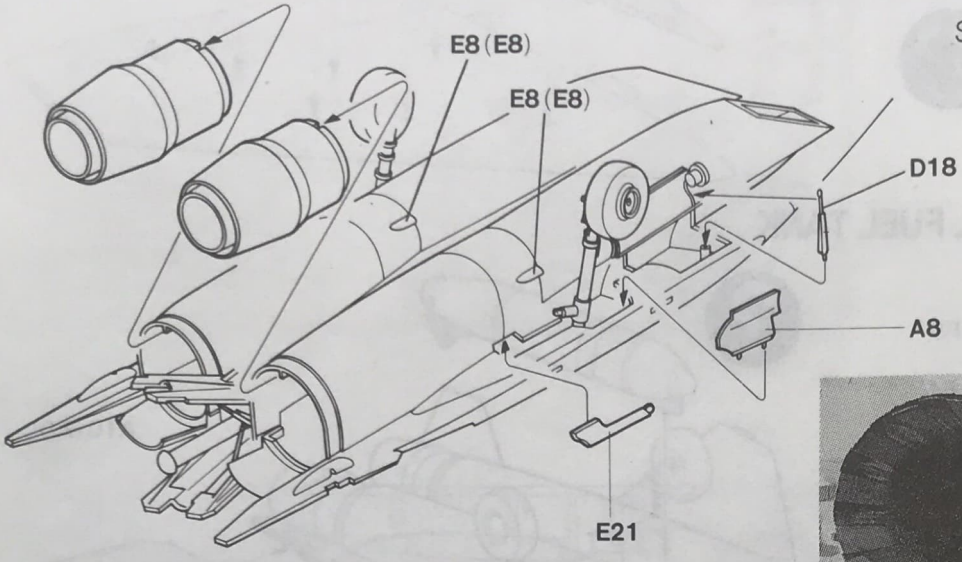
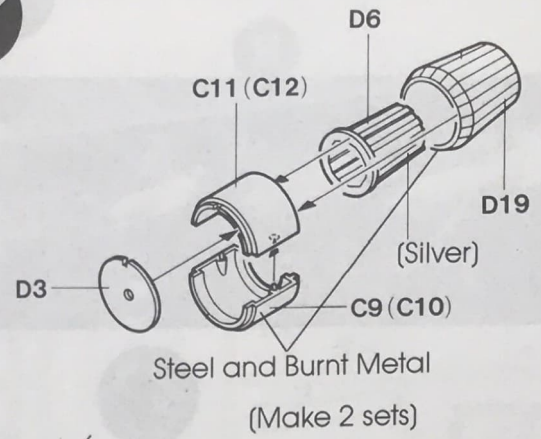
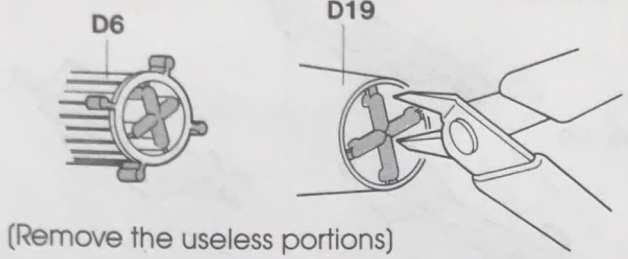

10 ASSEMBLY OF WING

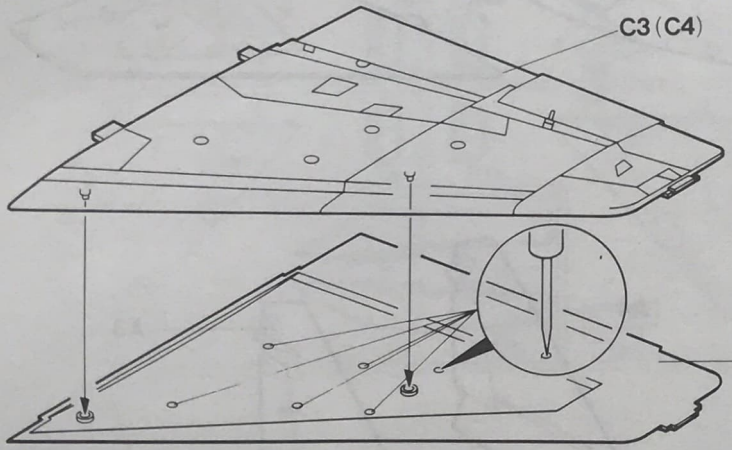

OPEN HOLES IF INSTALLING PYLONS



11 ASSEMBLY OF MISSILES I

■ R-27/AA-10D

■ R-73/AA-11

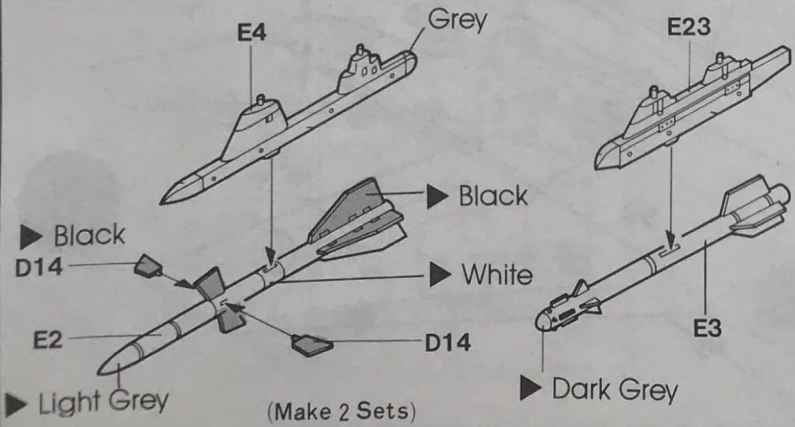

■ R-60MK/AA-8

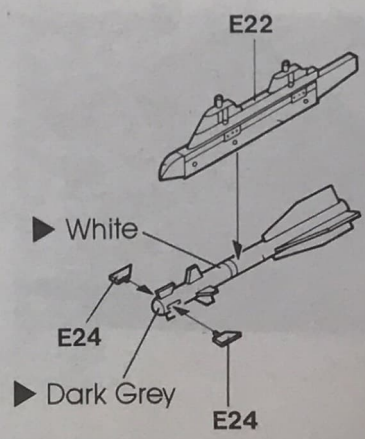
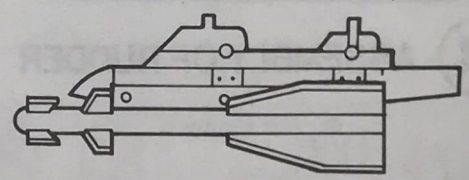

12 ASSEMBLY OF MISSILES II

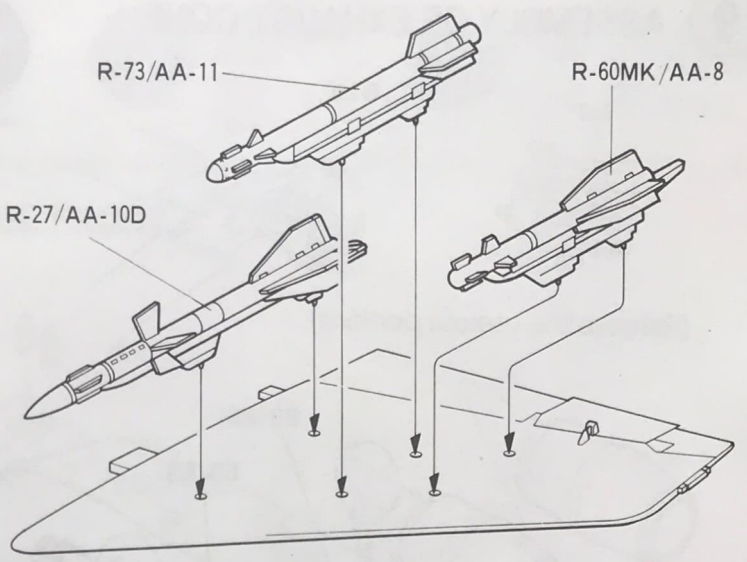
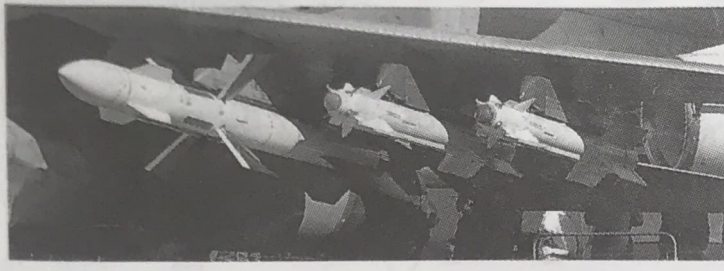

13 ASSEMBLY OF EXTERNAL FUEL TANK

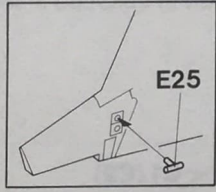
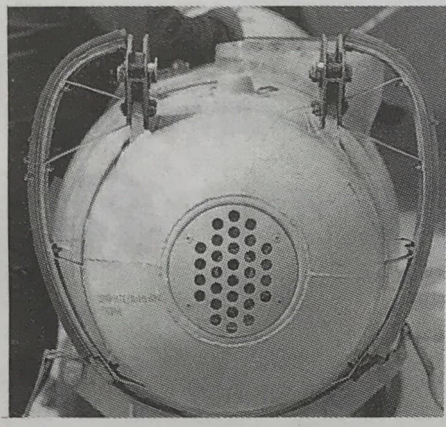
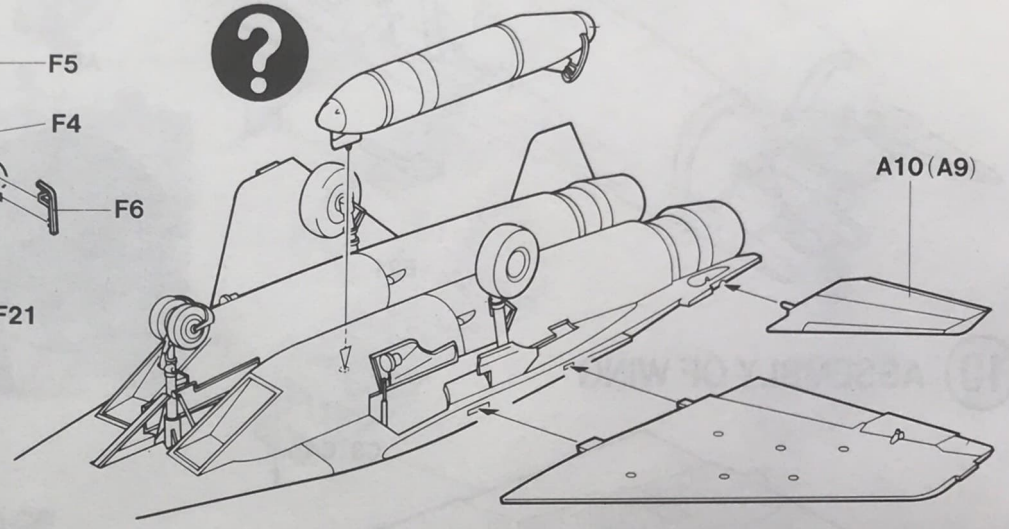
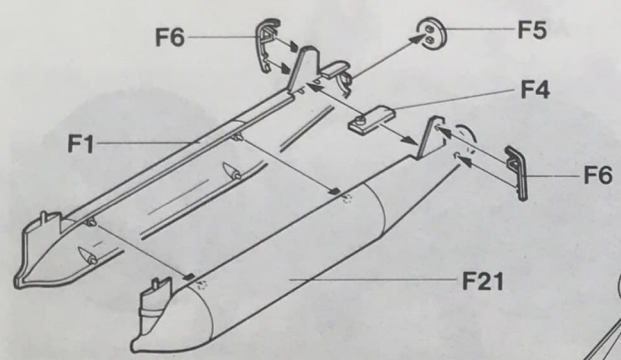

14 ASSEMBLY OF RUDDER

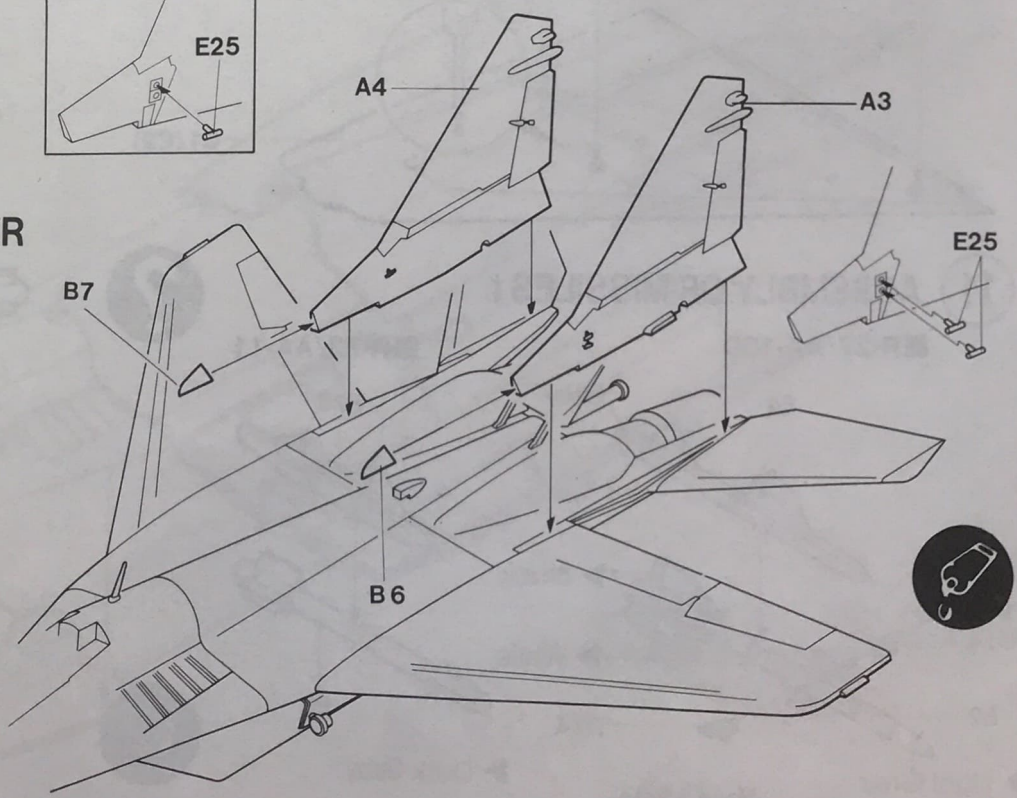
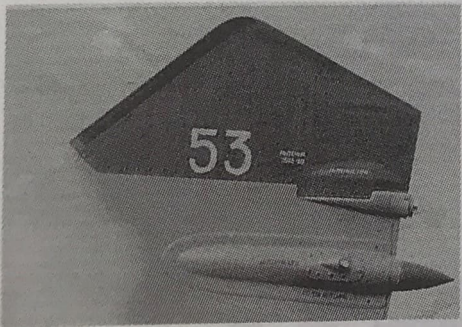

MiG 29 B Fulcrum Decal and Painting Instructions

West German Version

	GUNSHIP GRAY	FS 36118
	DARK GRAY	FS 36320
	MEDIUM GRAY	FS 36495
	LIGHT GRAY	FS 36628
	BLACK	

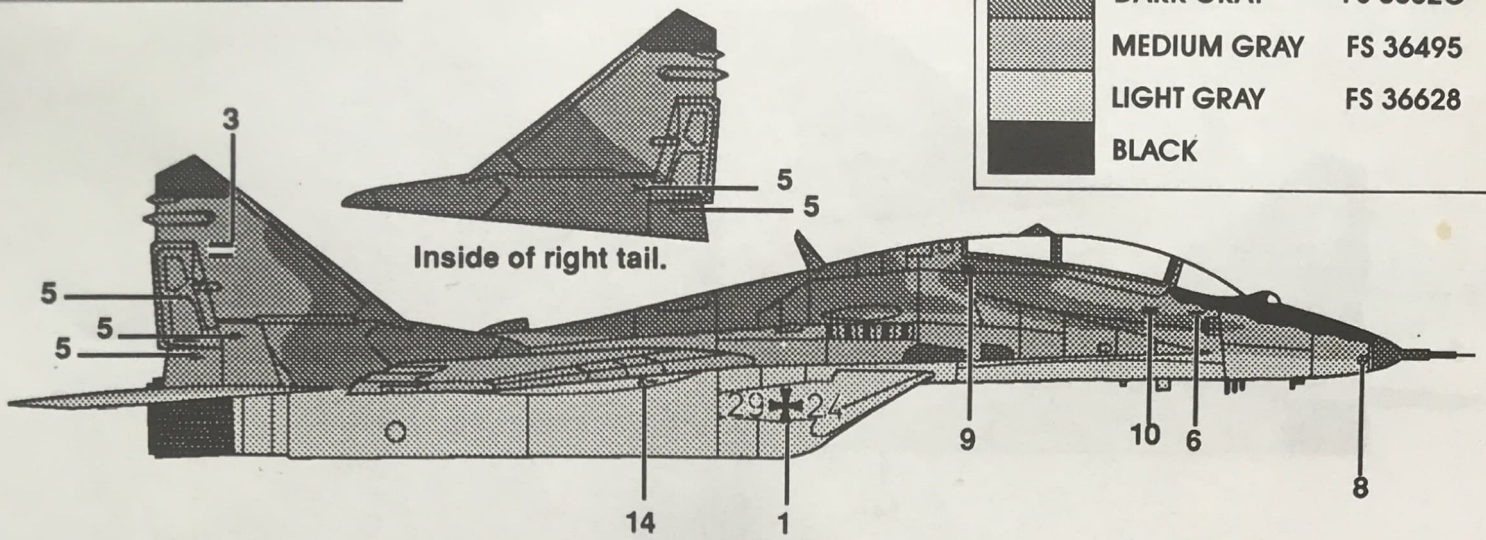

Inside of right tail.

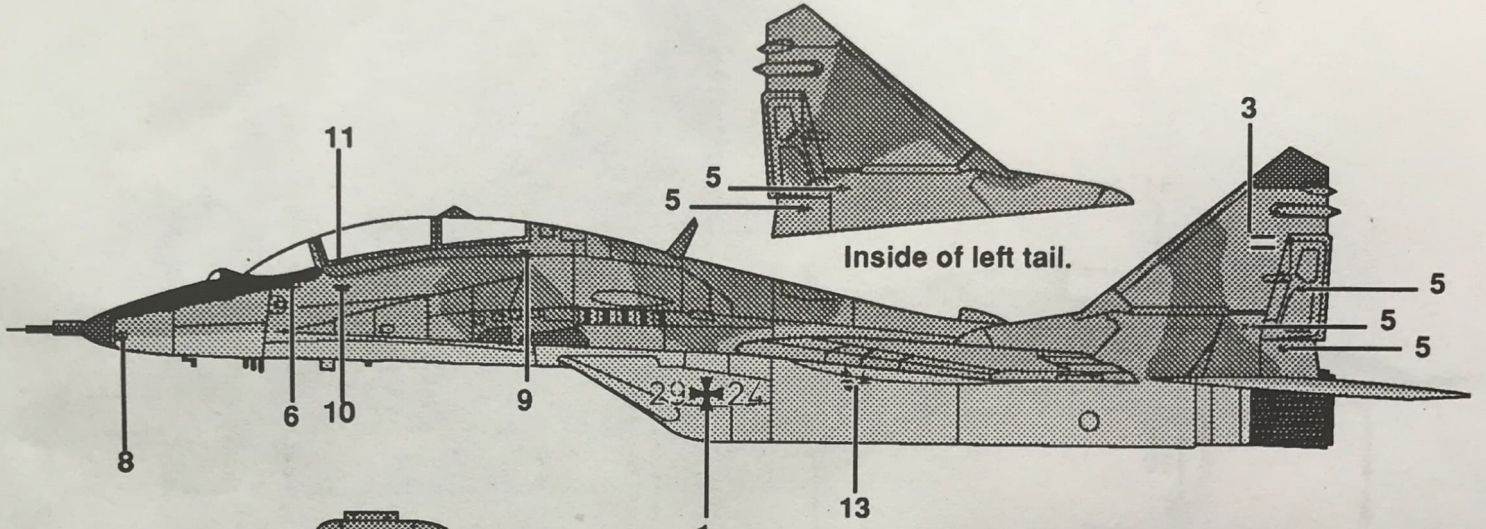

Inside of left tail.

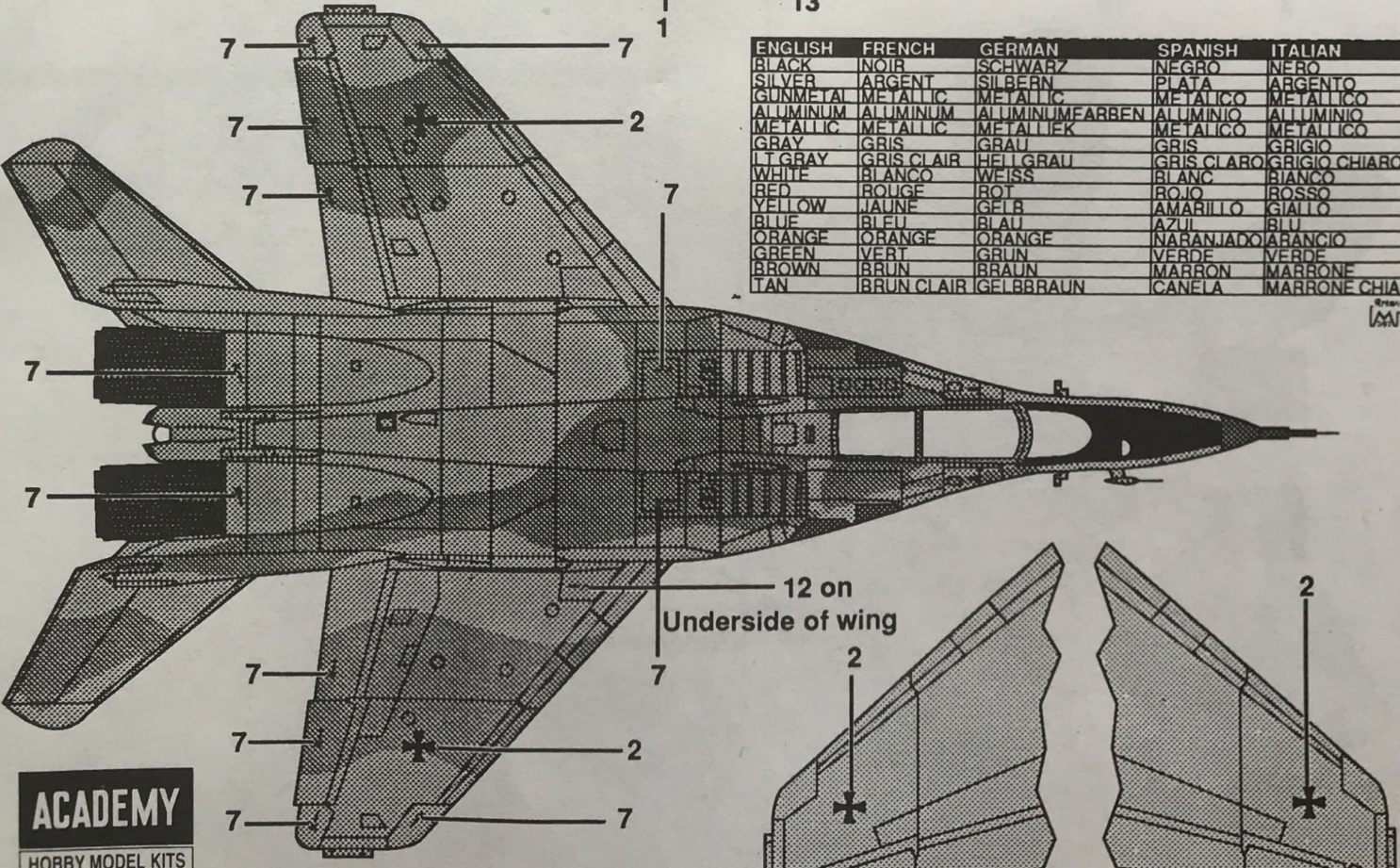

12 on
Underside of wing

Bottom of wings.

ENGLISH	FRENCH	GERMAN	SPANISH	ITALIAN
BLACK	NOIR	SCHWARZ	NEGRO	NERO
SILVER	ARGENT	SILBERN	PLATA	ARGENTO
GUNMETAL	METALLIC	METALLIC	METALLICO	METALLICO
ALUMINUM	ALUMINUM	ALUMINUMFARBEN	ALUMINIO	ALLUMINIO
METALLIC	METALLIC	METALLIEK	METALLICO	METALLICO
GRAY	GRIS	GRAU	GRIS	GRIGIO
LT GRAY	GRIS CLAIR	HELL GRAU	GRIS CLARO	GRIGIO CHIARO
WHITE	BLANCO	WEISS	BLANC	BIANCO
RED	ROUGE	ROT	ROJO	ROSSO
YELLOW	JAUNE	GELB	AMARILLO	GIALLO
BLUE	BLEU	BLAU	AZUL	BLU
ORANGE	ORANGE	ORANGE	NARANJADO	ARANCIO
GREEN	VERT	GRUN	VERDE	VERDE
BROWN	BRUN	BRAUN	MARRON	MARRONE
TAN	BRUN CLAIR	GELBBRAUN	CANELA	MARRONE CHIARO

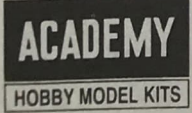

MIG 29 B Fulcrum Decal and Painting Instructions

Yugoslavian Version

	GUNSHIP GRAY	FS 36118
	DARK GRAY	FS 36320
	MEDIUM GRAY	FS 36495
	LIGHT GRAY	FS 36628
	BLACK	

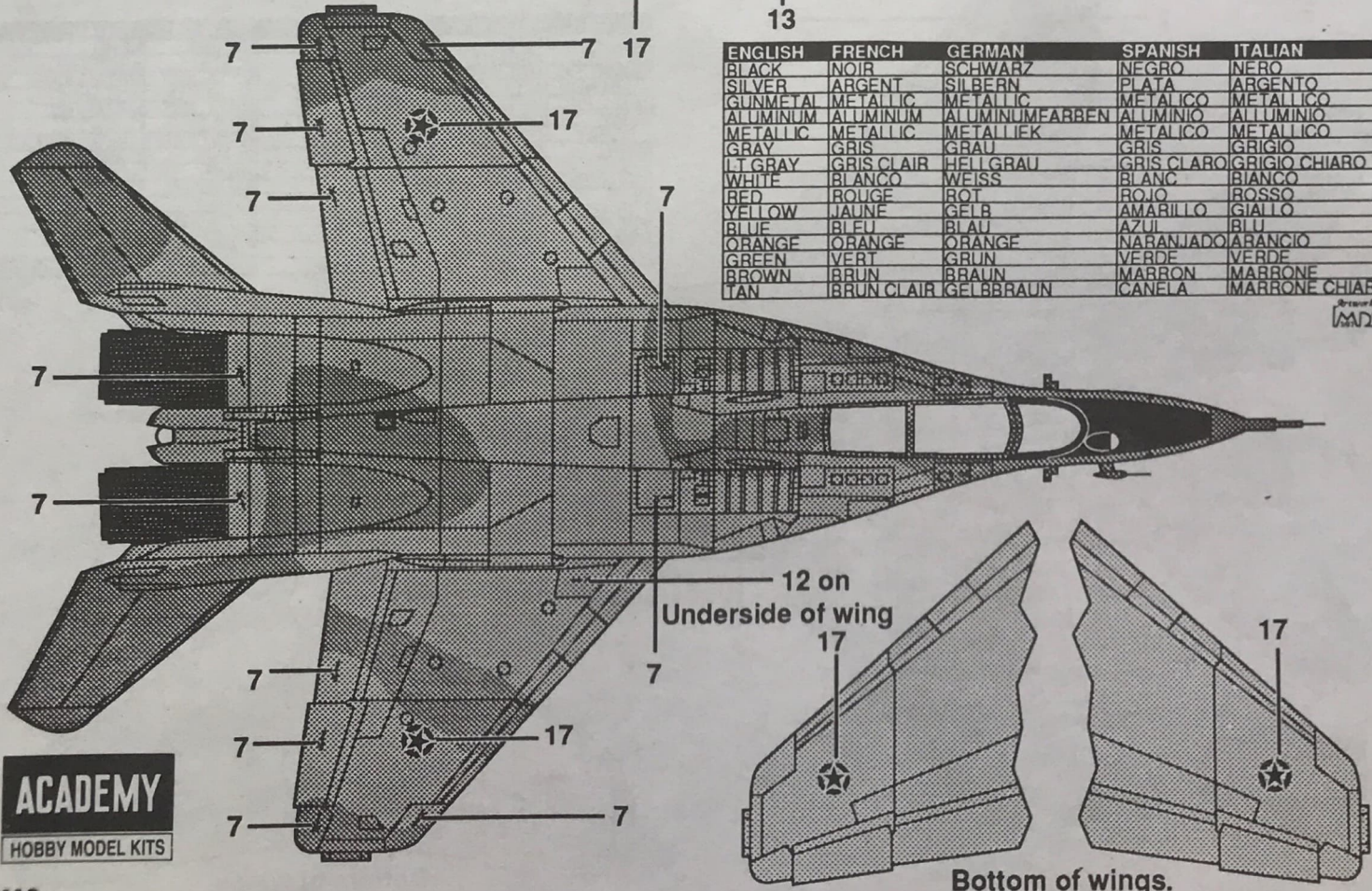
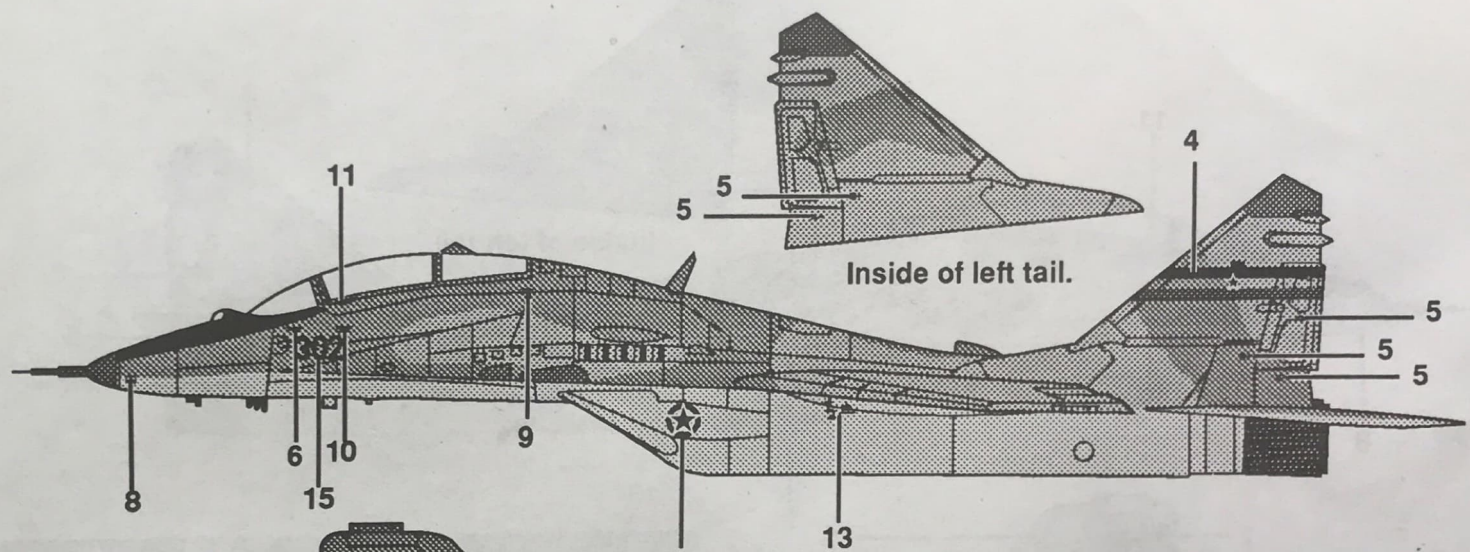
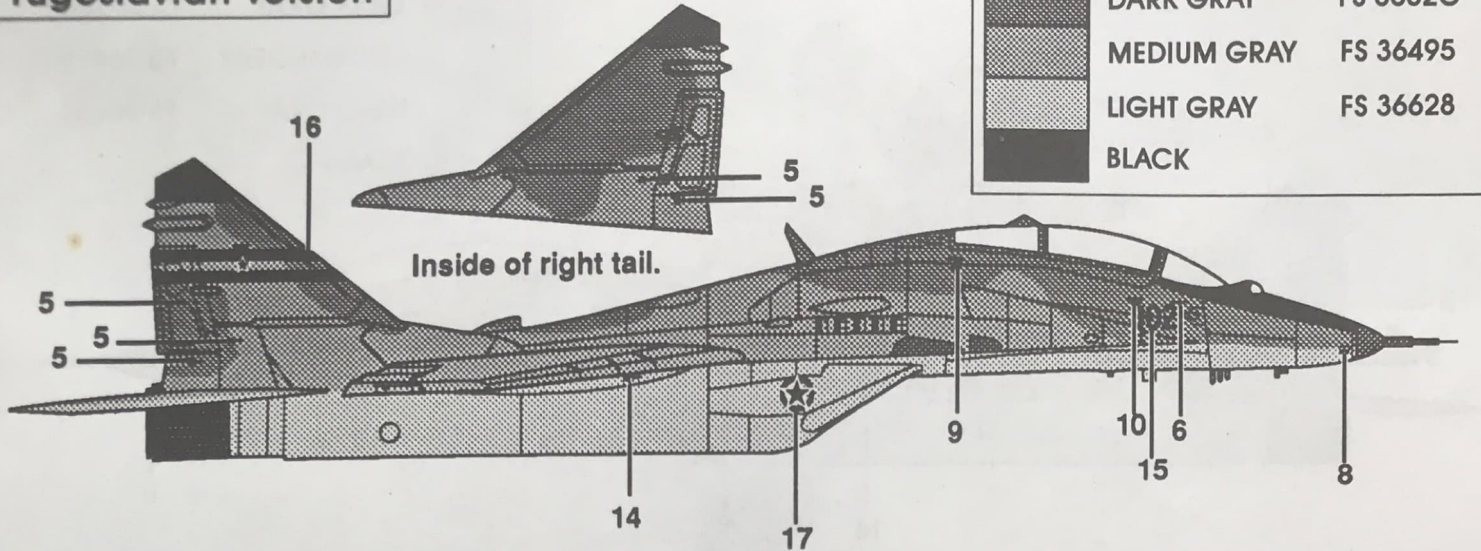

ENGLISH	FRENCH	GERMAN	SPANISH	ITALIAN
BLACK	NOIR	SCHWARZ	NEGRO	NERO
SILVER	ARGENT	SILBERN	PLATA	ARGENTO
GUNMETAL	METALLIC	METALLIC	METALICO	METALLICO
ALUMINIUM	ALUMINIUM	ALUMINUMFARBEN	ALUMINIO	ALUMINIO
METALLIC	METALLIC	METALLIEK	METALICO	METALLICO
GRAY	GRIS	GRAU	GRIS	GRIGIO
LT GRAY	GRIS CLAIR	HELLGRAU	GRIS CLARO	GRIGIO CHIARO
WHITE	BLANC	WEISS	BLANC	BIANCO
RED	ROUGE	ROT	ROJO	ROSSO
YELLOW	JAUNE	GELB	AMARILLO	GIALLO
BLUE	BLEU	BLAU	AZUL	BLU
ORANGE	ORANGE	ORANGE	NARANJADO	ABANCIO
GREEN	VERT	GRUN	VERDE	VERDE
BROWN	BRUN	BRUN	MARRON	MARRONE
TAN	BRUN CLAIR	GELBBRAUN	CANELA	MARRONE CHIARO

ACADEMY
HOBBY MODEL KITS

MIG 29B FULCRUM #2119

ACADEMY

HOBBY MODEL KITS

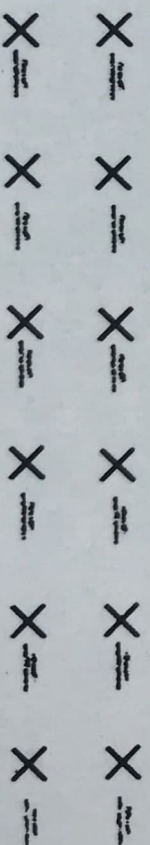
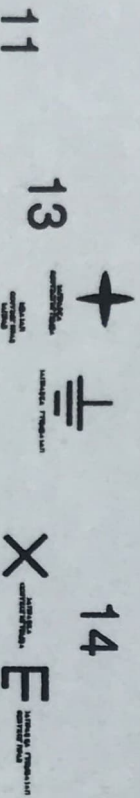
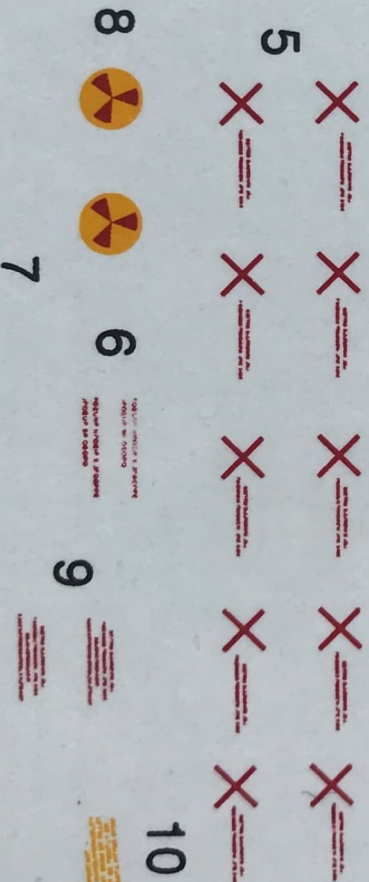
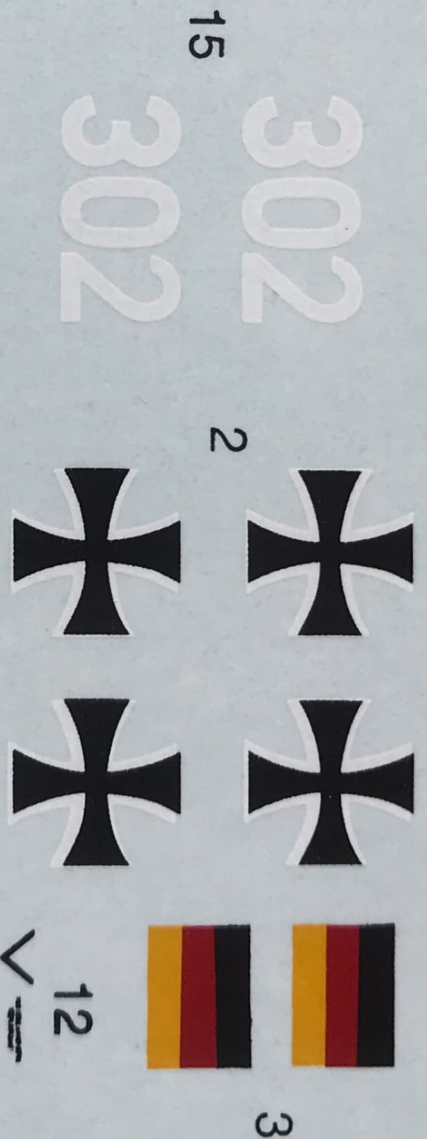

HOBBY MODEL KITS
ACADEMY

1/48th Scale SUKHOI SU-27 FLANKER B

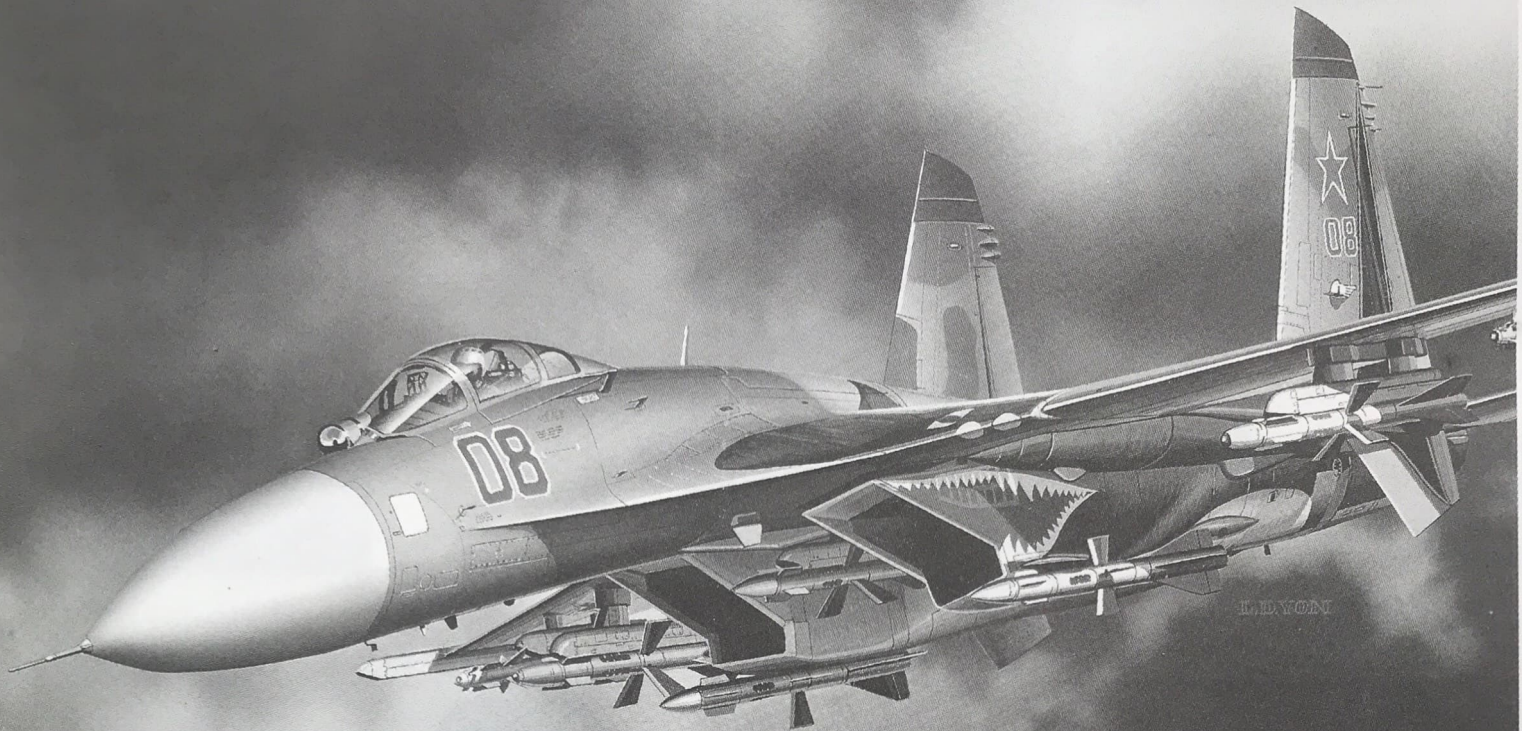

1/48th Scale SUKHOI SU-27UB FLANKER C

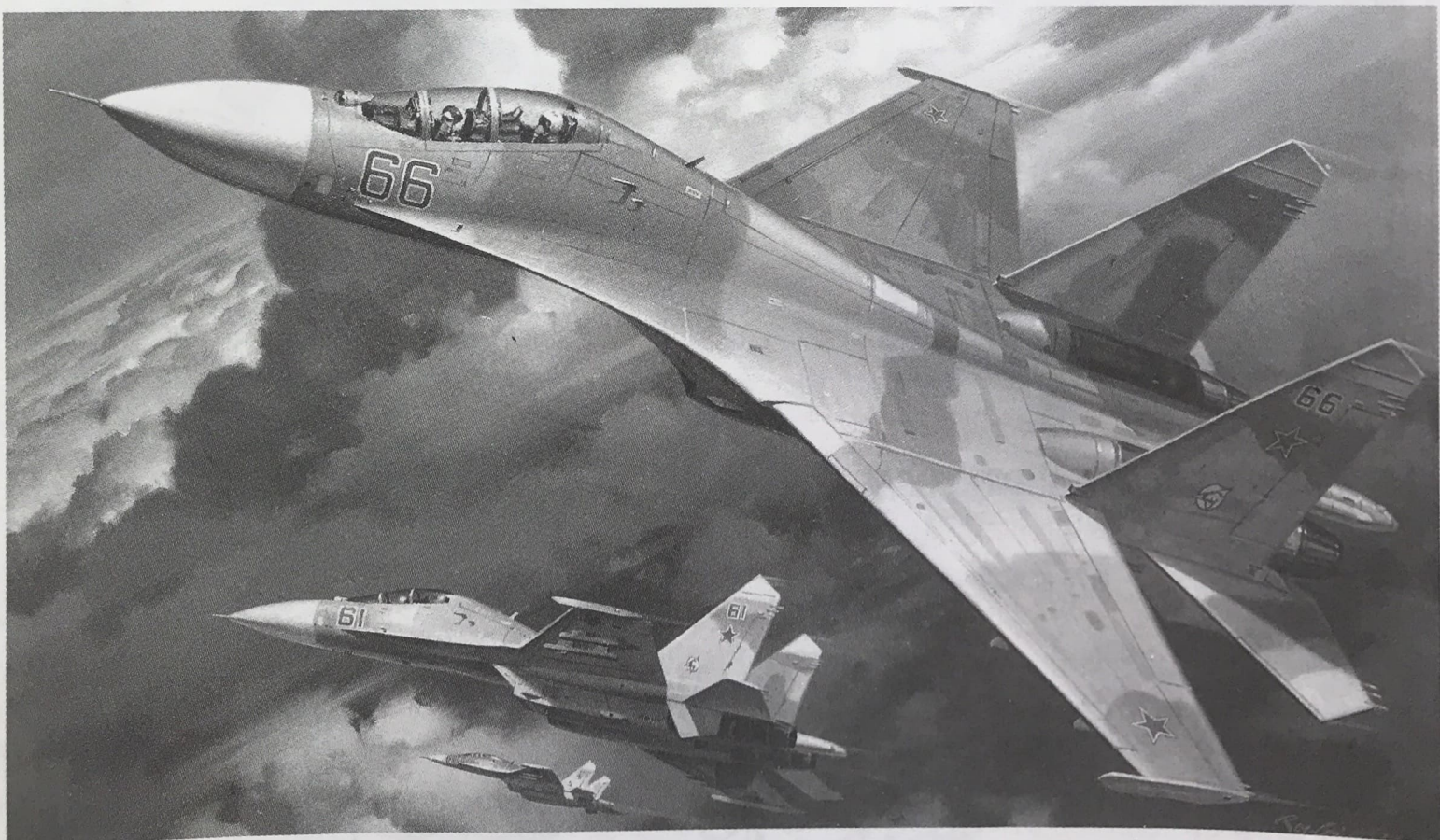

<http://academyhobby.com>
<http://academy.co.kr>

ACADEMY
HOBBY MODEL KITS

ACADEMY PLASTIC MODEL CO., LTD.
273-64, Suyu-dong, Kangbuk-gu, Seoul, Korea
TEL:82-2-908-7000 FAX:82-2-997-3003