



# 1:72 Douglas C-47 Skytrain™

A08014 SCALE MODEL CONSTRUCTION KIT | Wingspan: 400mm Fuselage Length: 273mm | Two Decal Schemes Included

**EN** Described by General Eisenhower as one of the four weapons that helped the Allies to win the Second World War, the Douglas DC3 and its military variant the C47 Skytrain (called Dakota in RAF service) has since gone on to be an instantly recognizable symbol of both air travel and the liberation of occupied lands that so characterized the Second World War.

Developed from the purely civilian Douglas DC2, the DC3 first flew in 1935 with the military C47 following suit in late 1941, shortly after the Japanese attack on Pearl Harbour. When it entered airline service in the late 1930s the DC3 revolutionized air transport, enabling journey times across the United States to be drastically reduced. Today, even approaching 80 years after its first flight, hundreds of DC3s and C47s remain in service throughout the world, its reliability and ability to deliver payload and passengers ensuring its longevity.

But it was as the C47 that the design truly found its calling. Instrumental in the invasion of France in 1944, the C47 dropped not only thousands of troops throughout the war but also delivered hundreds of thousands of tons of supplies, much needed by both troops and besieged civilian populations. Serving in the West with both the RAF and the USAAF as well as licence built examples serving in Russia with the Soviets, the C47

**FR** Selon le général Eisenhower, la variante militaire C47 du Douglas DC3 (appelé Dakota en service au sein de la RAF) était l'une des quatre armes qui ont aidé les Alliés à gagner la Deuxième Guerre mondiale. Depuis lors, il est devenu le symbole immédiatement reconnu du voyage aérien ainsi que de la libération des pays occupés pendant la guerre.

Développé à partir du Douglas DC2 entièrement civil, le DC3 a pris son premier vol en 1935, suivi par le C47 fin 1941, peu après l'attaque japonaise contre Pearl Harbor. Entré en service à la fin des années 1930, le DC3 a révolutionné le transport aérien, permettant de raccourcir le vol aux États-Unis. Aujourd'hui, grâce à sa fiabilité et à sa capacité de livrer des cargaisons et des passagers, il y a des centaines de DC3 en service dans le monde entier, même presque 80 années après son vol inaugural.

En 1944, le concept du C47 a vraiment trouvé sa vocation, en jouant un rôle-clé dans l'invasion de la France. Pendant la guerre, il a parachuté des milliers de troupes mais aussi des centaines de milliers de tonnes d'approvisionnements pour militaires et civils assaillis mais survivants. L'avion était en service au sein de la RAF et de l'USAAF dans l'Ouest, et des exemplaires fabriqués sous licence ont servi en Russie avec l'armée de l'air soviétique. Le C47 s'est trouvé également en Extrême-Orient où il a entrepris des missions d'approvisionnement périlleuses vers la Chine en survolant la chaîne de l'Himalaya. On l'a même utilisé pour

**DE** Von General Eisenhower als eine jener vier Waffen bezeichnet, die den Alliierten zu ihrem Sieg im Zweiten Weltkrieg verhelfen, ist die Douglas DC3 und ihre militärische Variante, die C47 (Dakota im Dienst der RAF) seither zu einem weithin erkennbaren Symbol der Luftfahrt wie auch der Befreiung von besetzten Ländern geworden, welche ein kennzeichnendes Merkmal des Zweiten Weltkriegs bildete.

Auf der Grundlage der für den zivilen Luftverkehr gebauten Douglas DC2 entwickelt, hob die DC3 zum ersten Mal 1935 von der ihrer Startpiste ab. Die C47 folgte erst 1941, kurz nach dem japanischen Angriff auf Pearl Harbour. Als sie in den späten 1930er Jahren in den aktiven Dienst übernommen wurde, revolutionierte die DC3 den Lufttransport, da nun die Vereinigten Staaten in drastisch verkürzter Zeit überflogen werden konnten. Obwohl es nun nicht mehr sehr lange dauern wird, bis 80 Jahre seit dem Erstflug der DC3 vergangen sein werden, sind heute noch Hunderte davon überall auf der Welt im Einsatz. Die Zuverlässigkeit, mit der sie Nutzlasten wie auch Passagiere befördert, hat ihre lange Verwendungsdauer gewährleistet.

Die Konstruktion der C47 hat sich immer wieder erneut bewährt. Die Maschine war 1944 entscheidend an der Invasion von Frankreich beteiligt. Sie brachte Tausende Soldaten zu ihrem Einsatzort, lieferte aber auch riesige Mengen von Nachschub an, die sowohl Truppen als auch durch den Krieg eingeschlossenen Überlebenden der Zivilbevölkerung dringend benötigte Hilfe brachten. Im Westen von der RAF wie auch der USAAF eingesetzt, wurden unter Lizenz gebaute Maschinen auch von den Sowjets in Russland verwendet.

was even to be found in the Far East, undertaking perilous supply missions to China, flying over 'the hump' of the Himalayas. It was even used to deliver vehicles such as Jeeps to forward bases. After the war ended the C47 continued to serve as a supply aircraft throughout the Berlin airlift as well as undertaking dangerous roles in the Arctic Circle, equipped with ski undercarriages. C47s even saw service during the Vietnam War as a gunship, nicknamed 'Puff the Magic Dragon'. C47s continue in service with some air arms even today, with many being up-engined to Turbo-prop power plants.

### Specification

Maximum Speed: 224 mph (360km/h)

Range: 1,600 miles (2,575 km)

Wingspan: 95 ft 6 in (29.41m)

Length: 63 ft 9.0 in (19.43 m)

la livraison des véhicules tels que des Jeep aux bases en première ligne.

Après la fin de la guerre, le C47 a continué son rôle d'avion d'approvisionnement au cours du pont aérien de Berlin. Muni d'un train d'atterrissage monté sur skis, il a joué des rôles dangereux dans le cercle polaire arctique. Pendant la guerre du Vietnam, il a été utilisé en tant qu'avion de combat surnommé « Puff le dragon enchanté ». Même aujourd'hui, le C47 est toujours opérationnel au sein de certaines forces aériennes ; il y en a beaucoup motorisés par des turbopropulseurs.

### Specification:

Vitesse maximale: 360 km/h

Autonomie: 2.575 km

Envergure: 29,41 m

Longueur: 19,43 m

Die C47 war auch im Fernen Osten zu finden und unternahm riskante Nachschubmissionen nach China, wobei sie die steil aufragende Gebirgskette des Himalaja überflog. Sie transportierte sogar Jeeps zu militärischen Vorposten.

Nach Kriegsende diente die C47 weiterhin als Versorgungsflugzeug während der Blockade von Berlin. Sie führte auch gefährliche Aufgaben im Nördlichen Polarkreis aus, wobei ihr Fahrwerk mit Kufen ausgerüstet war. Im Vietnamkrieg diente sie auch als Kampfmaschine und wurde in dieser Rolle mit dem Spitznamen „Puff the Magic Dragon“ bedacht. Es sollte daher kaum überraschen, dass die C47 auch heute noch von manchen Fliegerruppen verwendet wird, wobei viele Maschinen mit leistungsstärkeren Turboprop-Triebwerken umgerüstet wurden.

### Spezifikation:

Höchstgeschwindigkeit: 360 km/h

Reichweite: 2.575 km

Spannweite: 29,41 m

Länge: 19,43 m

Airfix would like to thank: Vintage Fabrics, Aces High Aviation for their assistance with this project.

Please visit [www.aceshigh-aviation.com](http://www.aceshigh-aviation.com) for more information

### FOR BEST RESULTS:

Surfaces to be painted should be clean — before parts are removed from the sprue, wash in warm, soapy water, rinse and dry thoroughly. Stir paints thoroughly before use.

### PLEASE NOTE:

Some parts in the kit may not be required to build the model specified.



Manufactured by: Hornby Hobbies Ltd Westwood, Margate, Kent, CT9 4JX, UK +44(0)1843 233525 [customerservices.uk@hornby.com](mailto:customerservices.uk@hornby.com)

EU Authorised Representative: Hornby Italia SRI Viale de' Caduti, 52/A6 Castel Mella (BS) Italy 25030 +39 0687501292 [customerservices.it@hornby.com](mailto:customerservices.it@hornby.com)



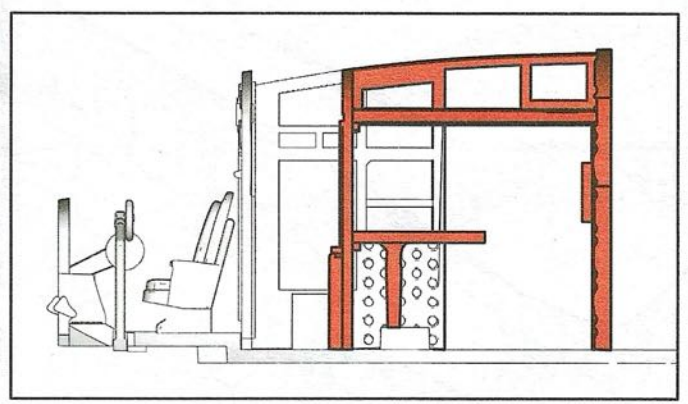
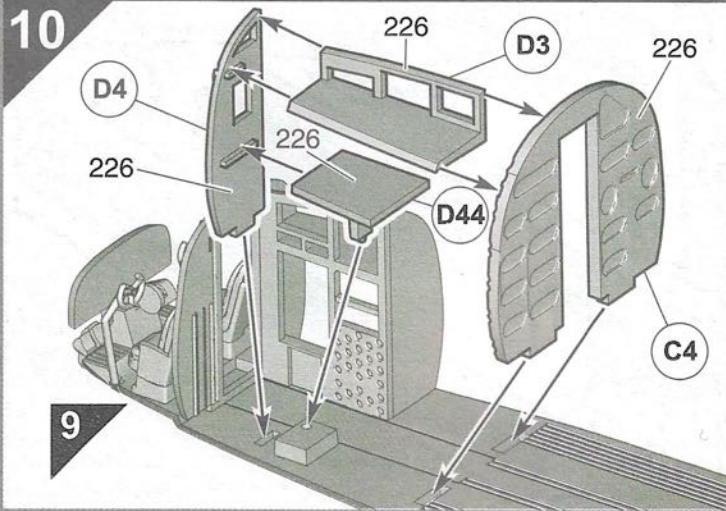
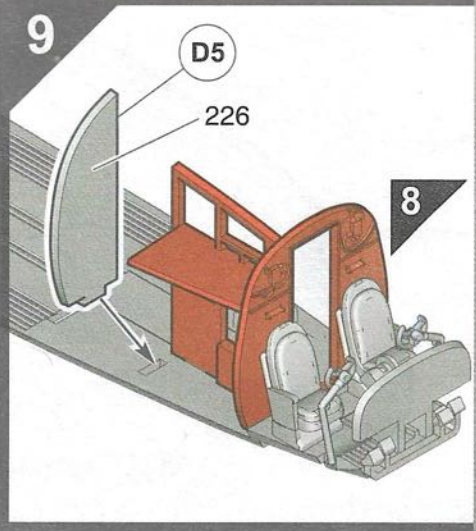
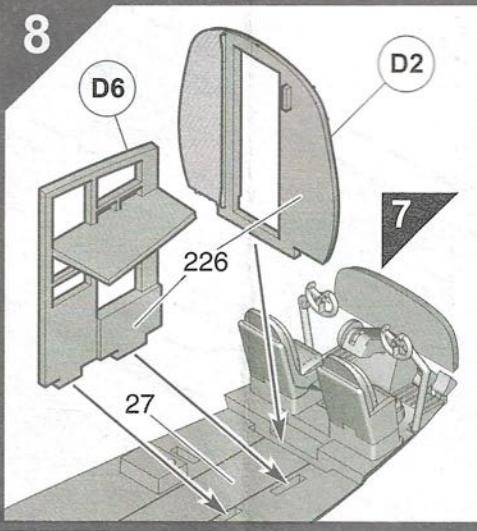
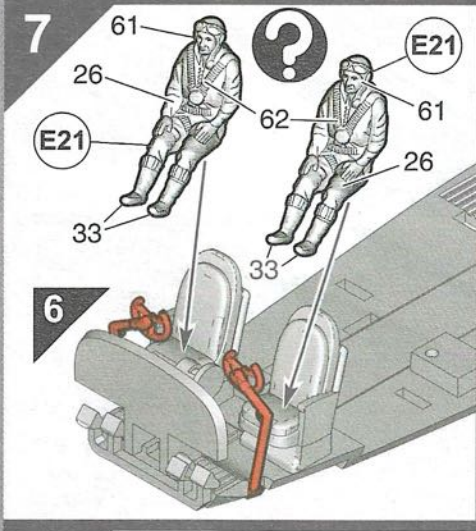
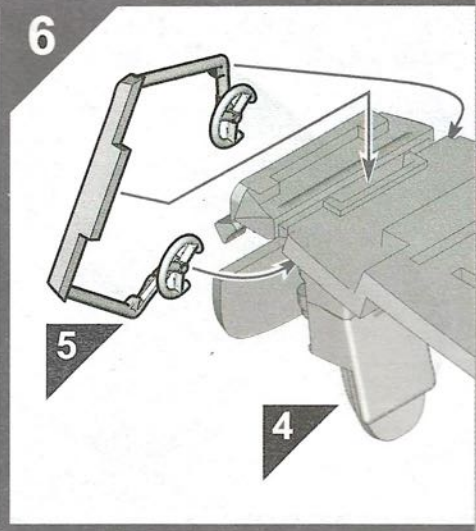
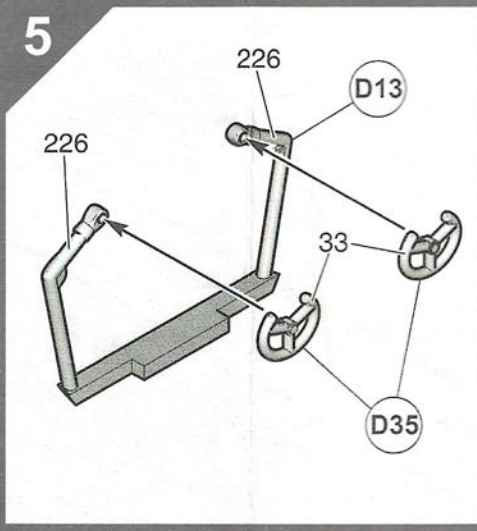
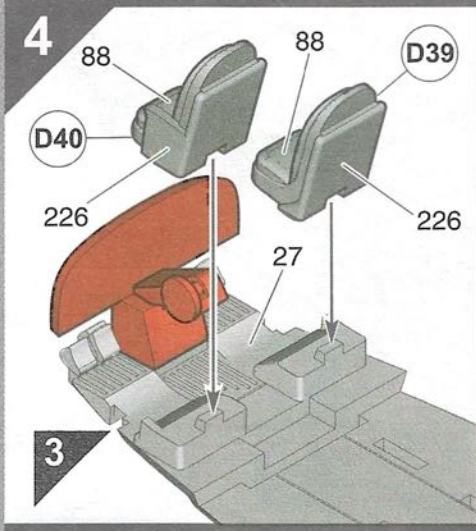
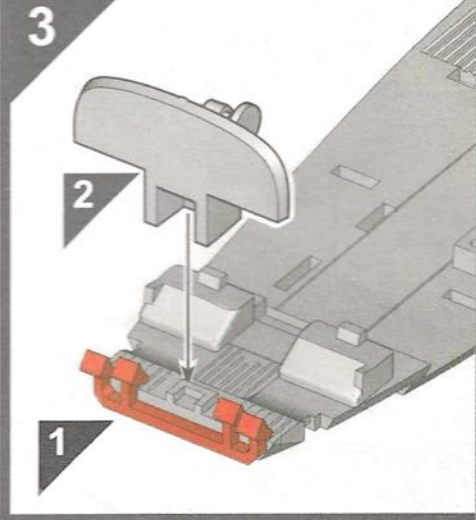
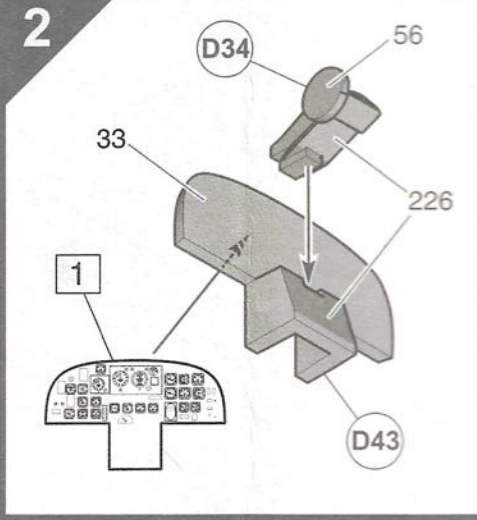
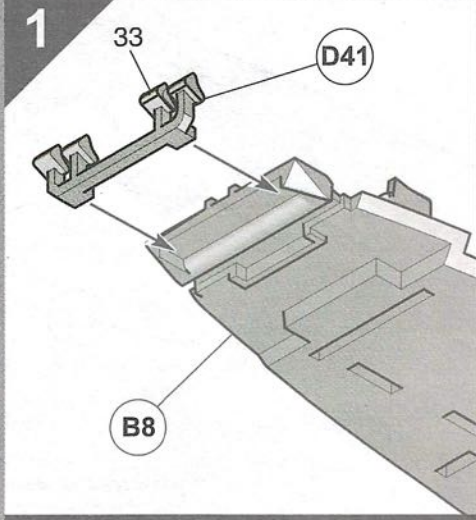

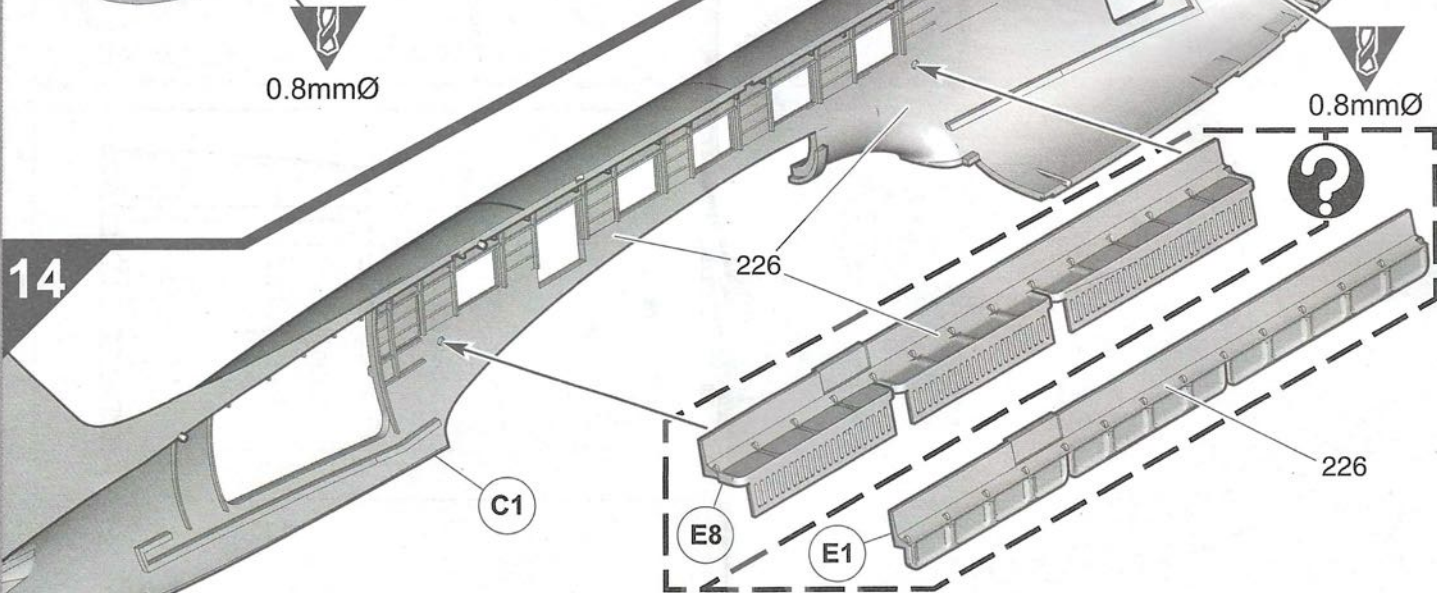
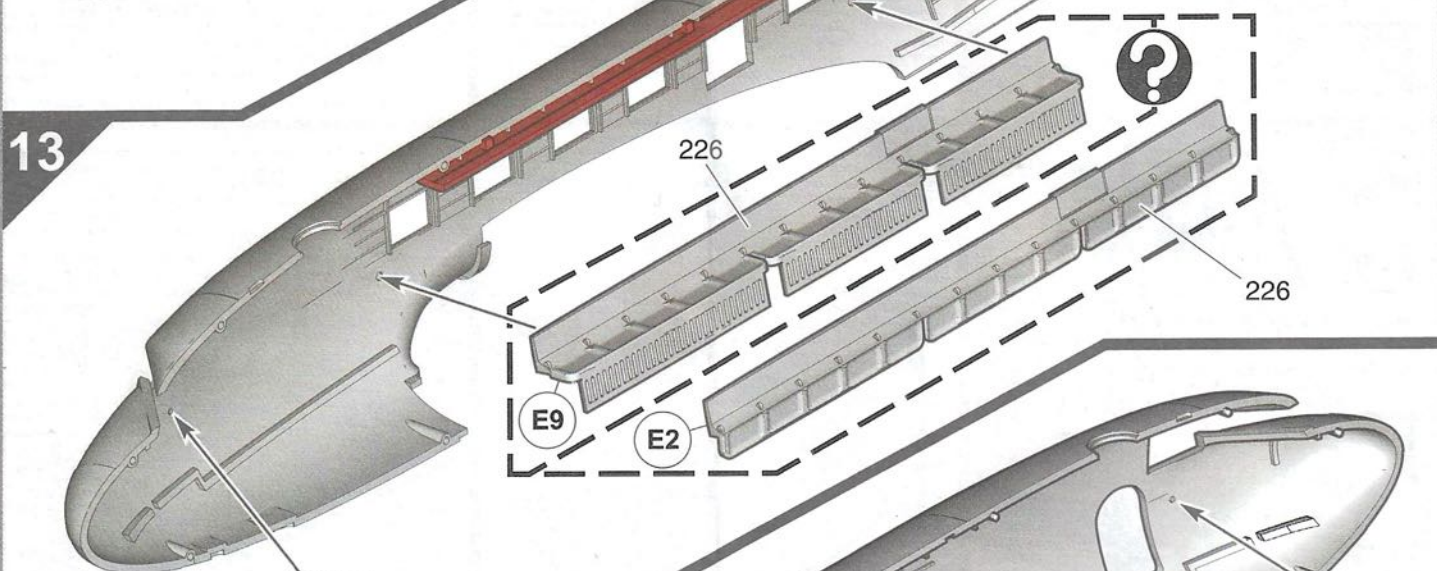
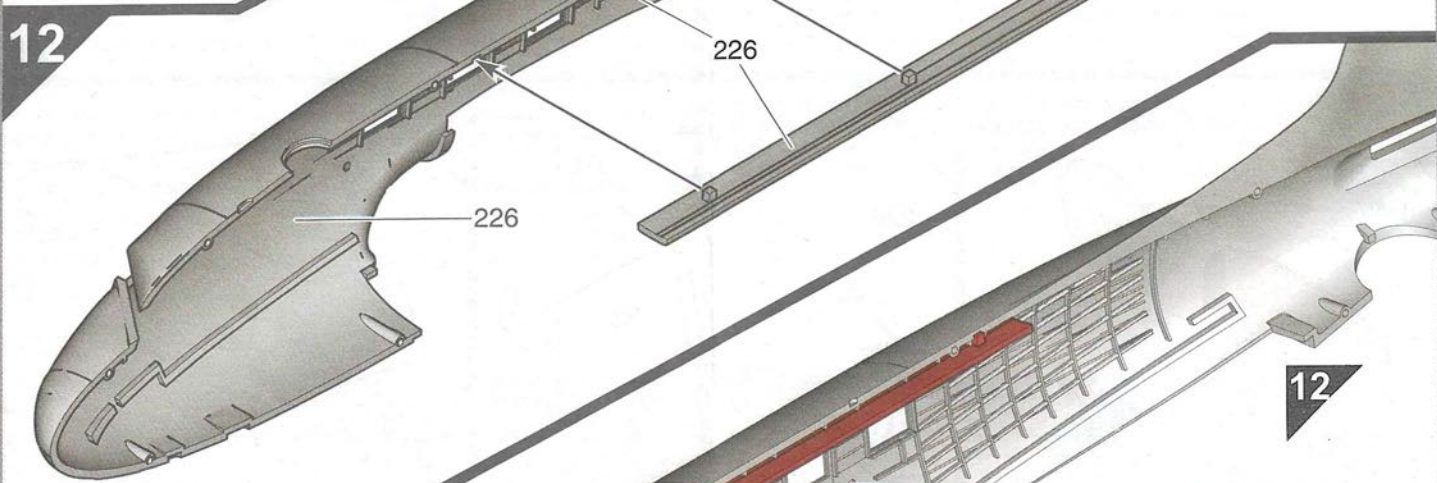
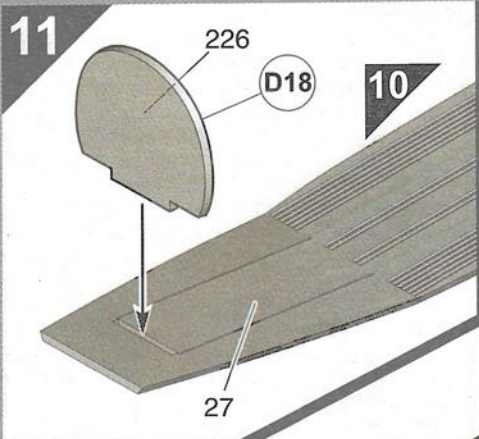

15

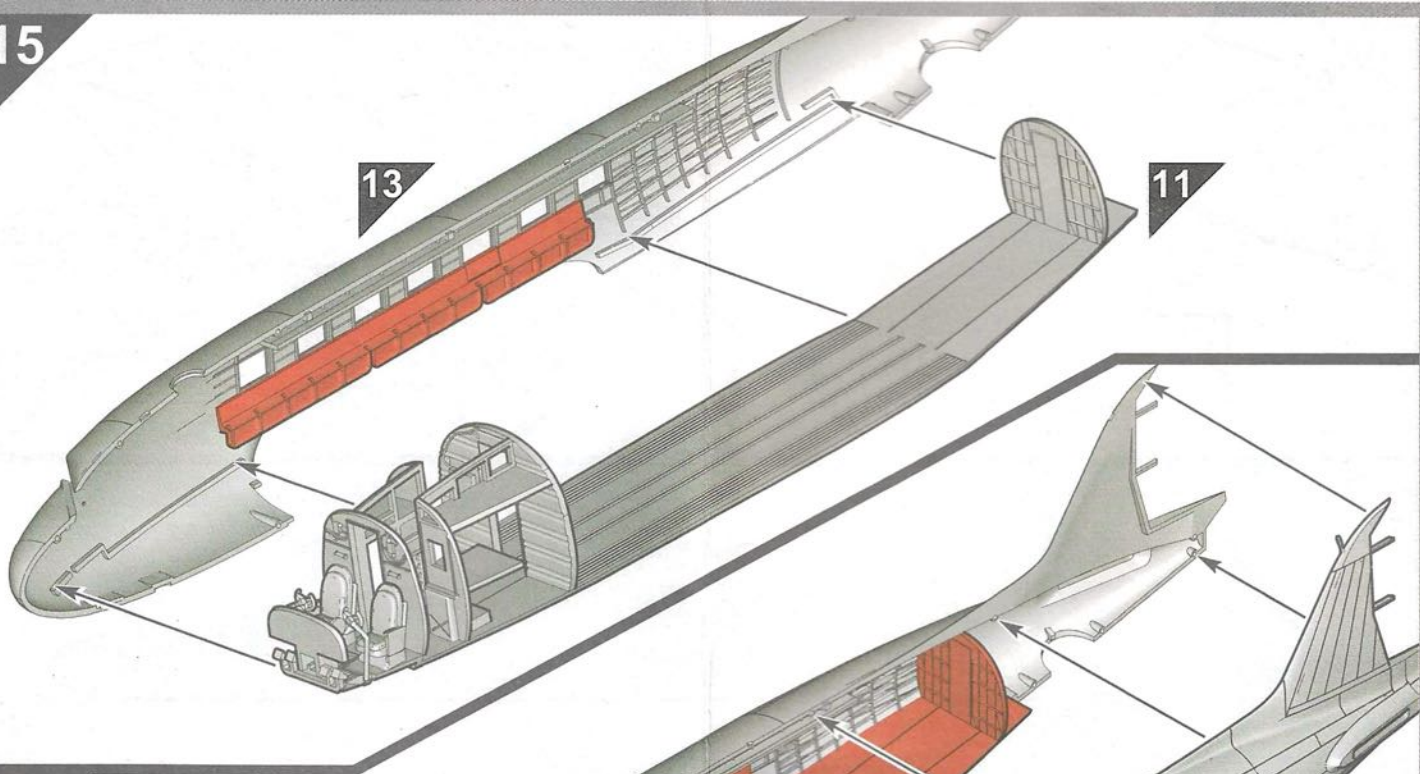

16

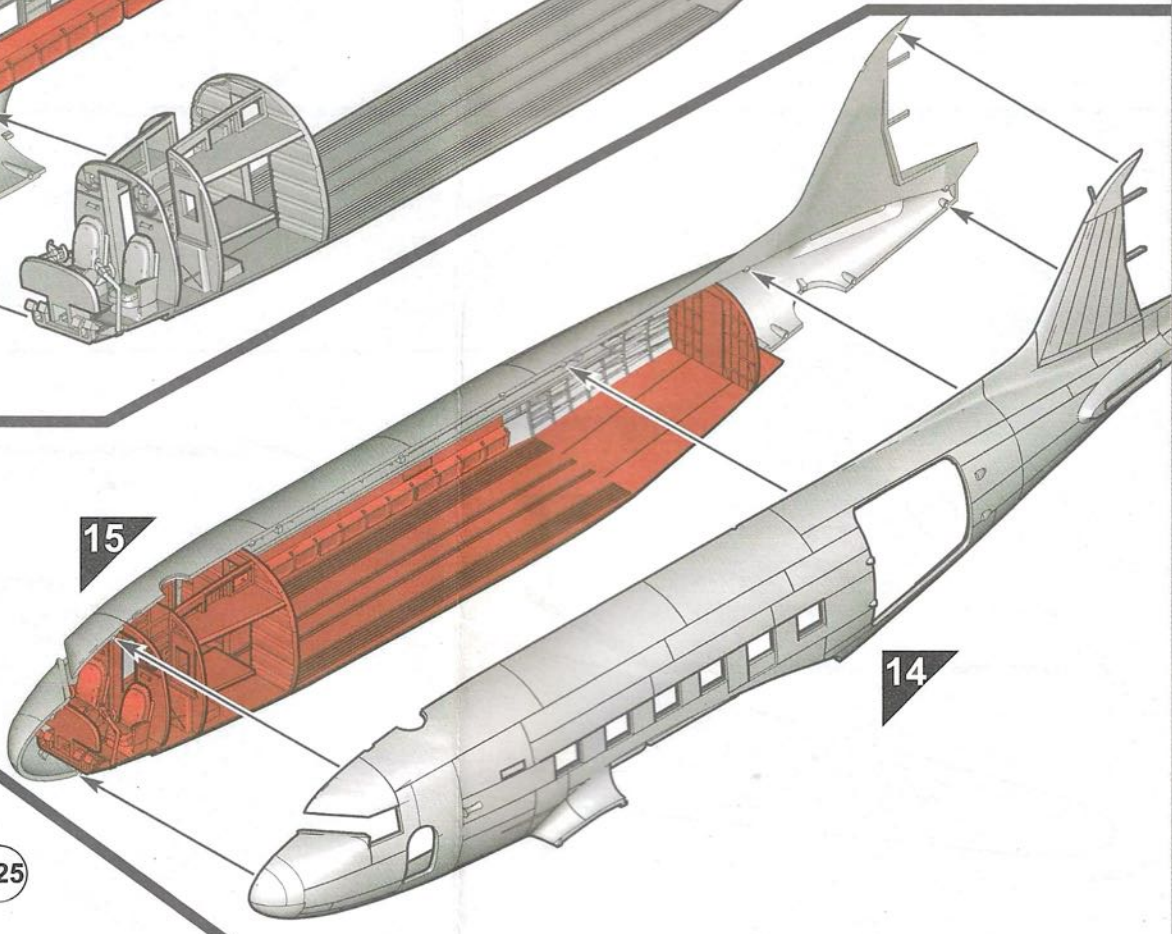

17

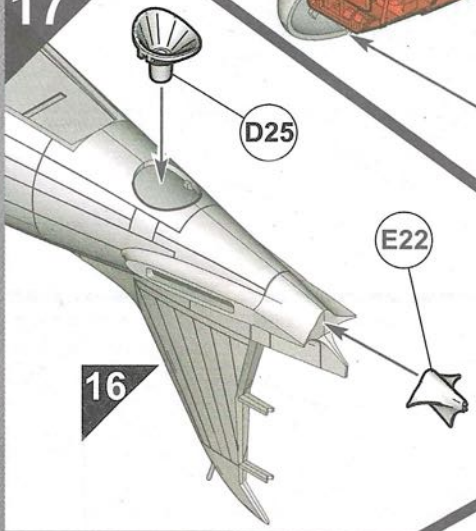

19

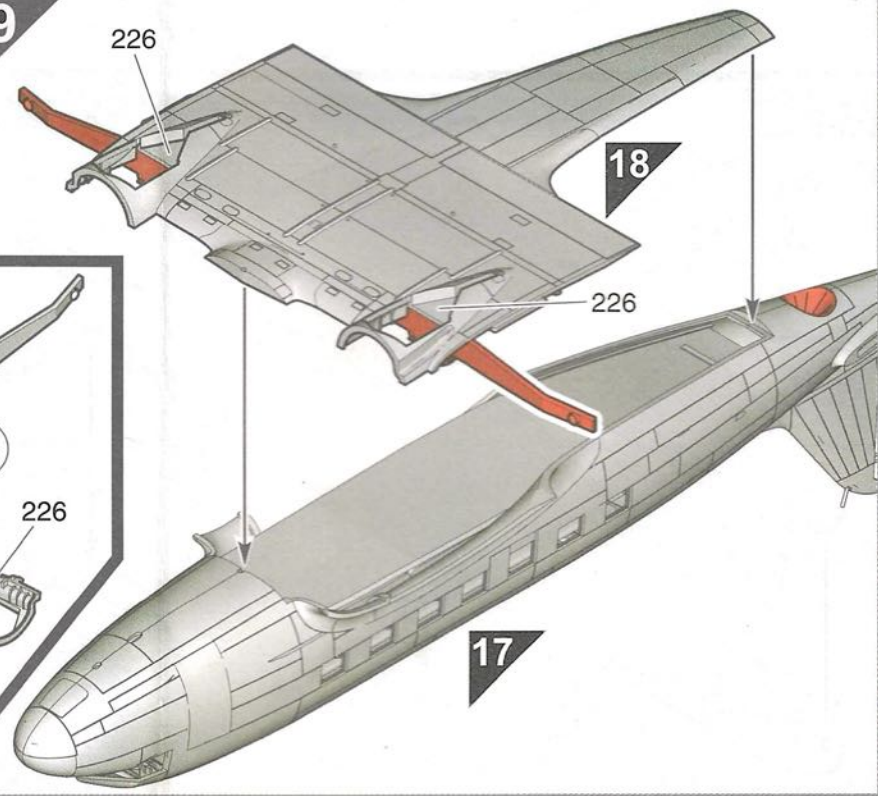

18

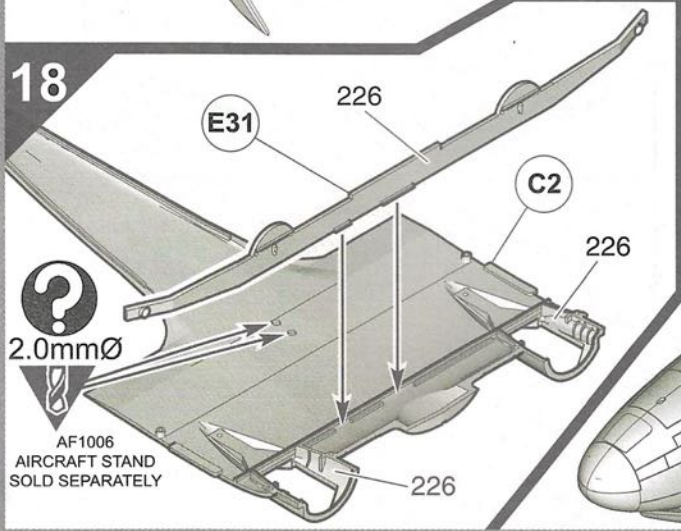

2.0mmØ

AF1006 AIRCRAFT STAND SOLD SEPARATELY

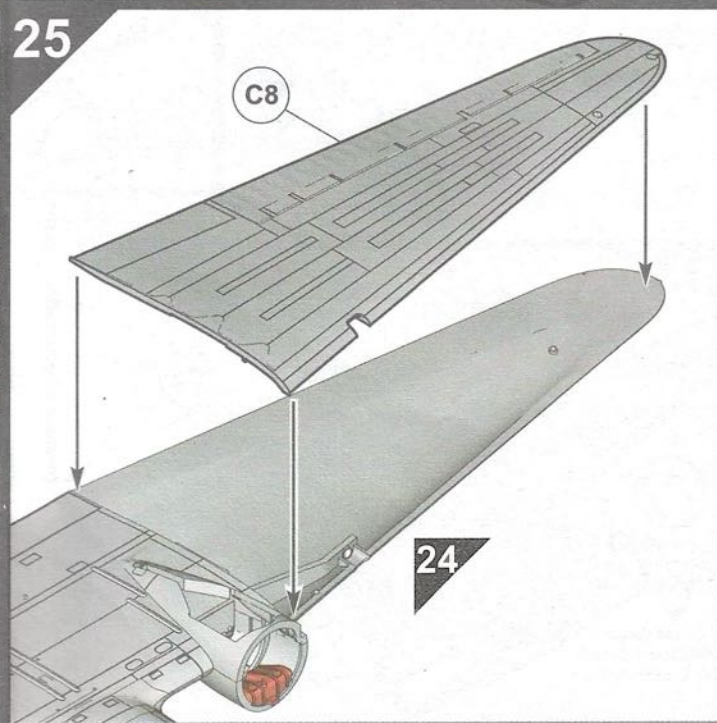
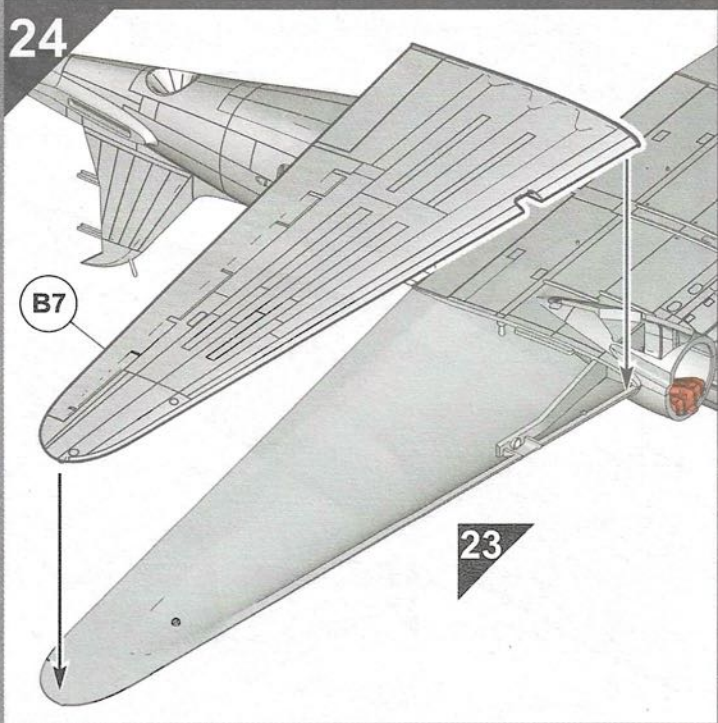
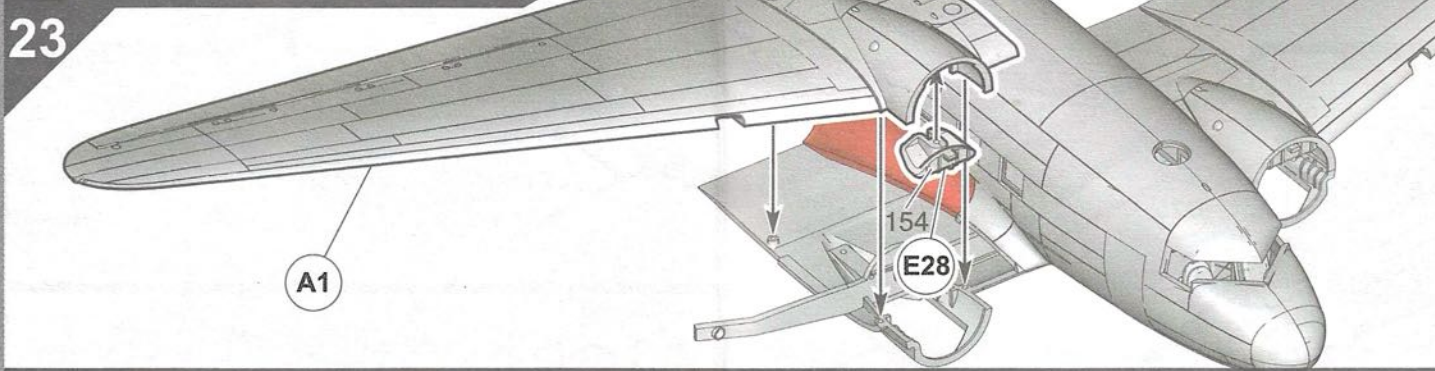
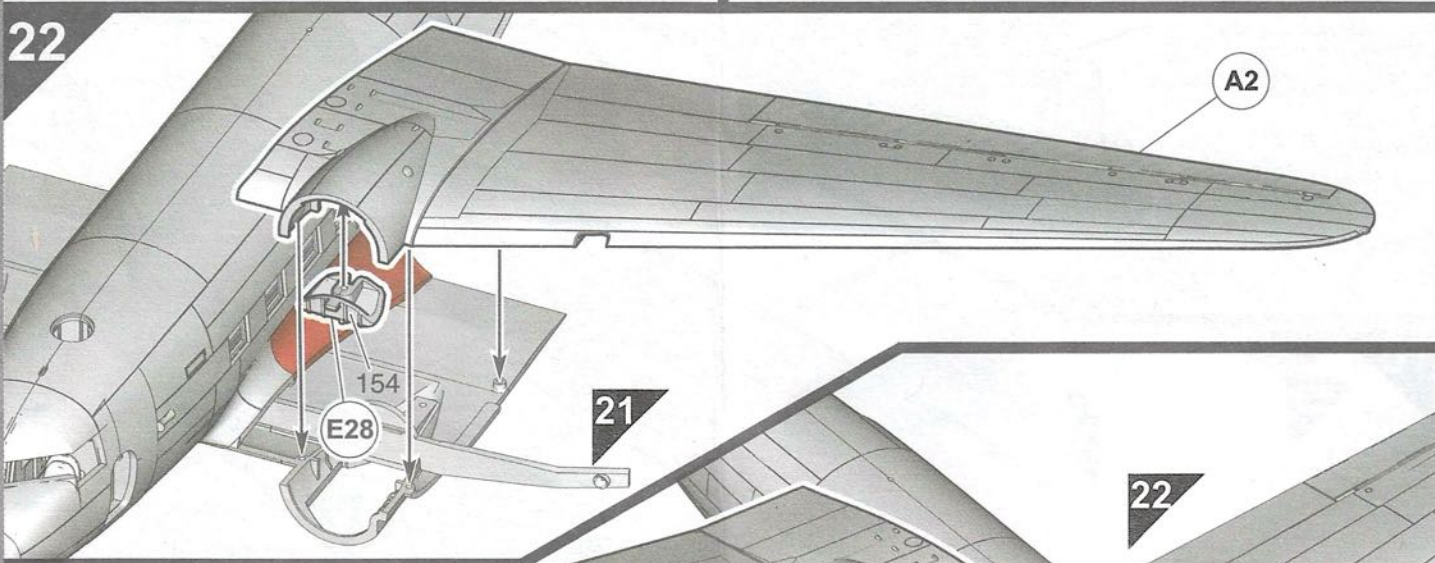
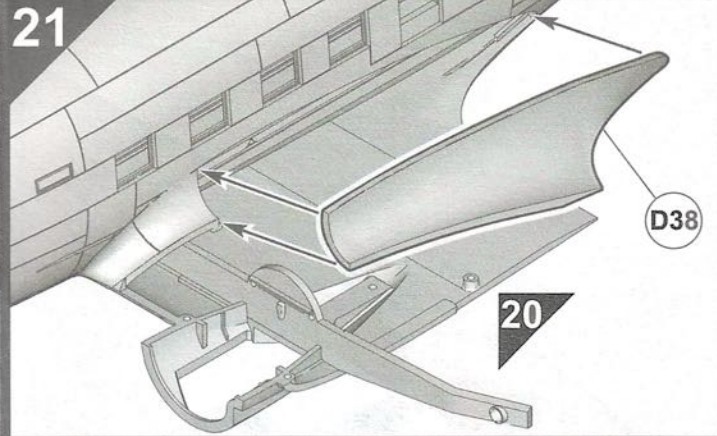
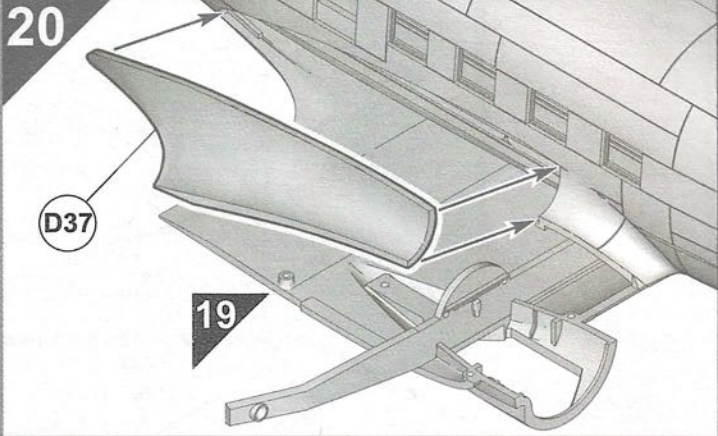

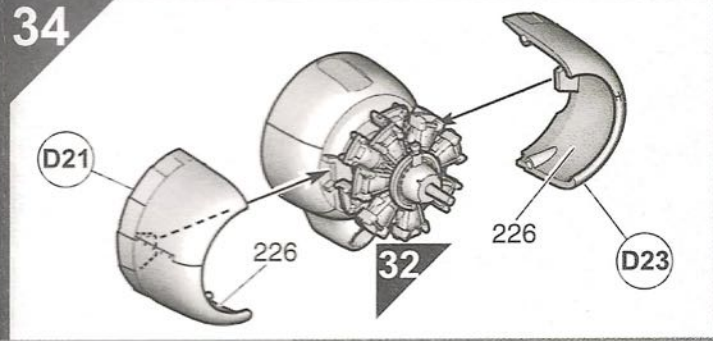
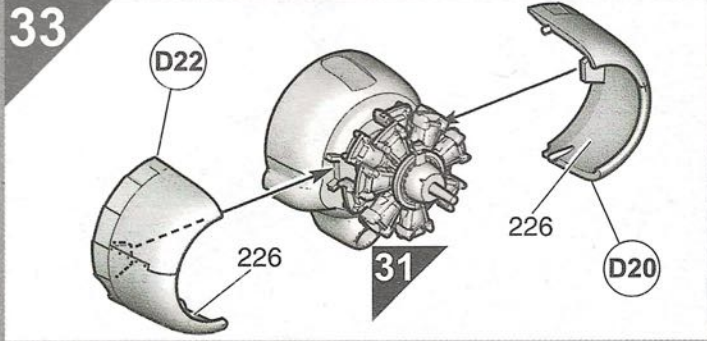
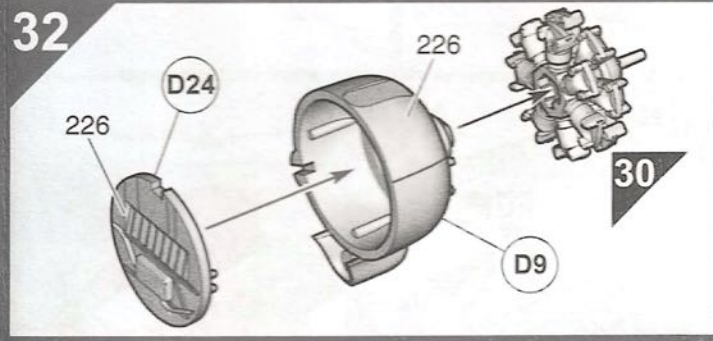
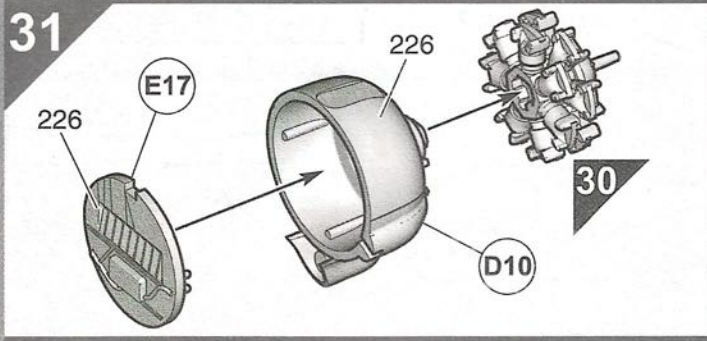
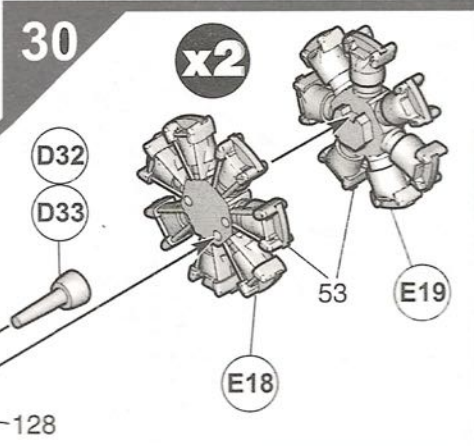
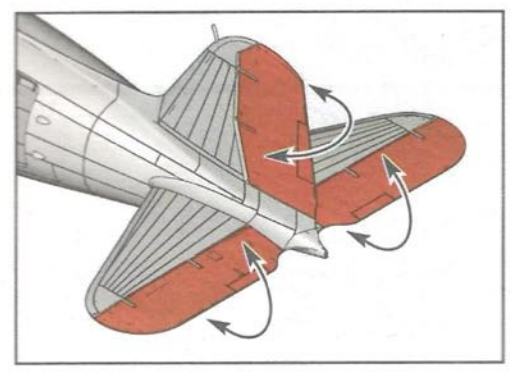
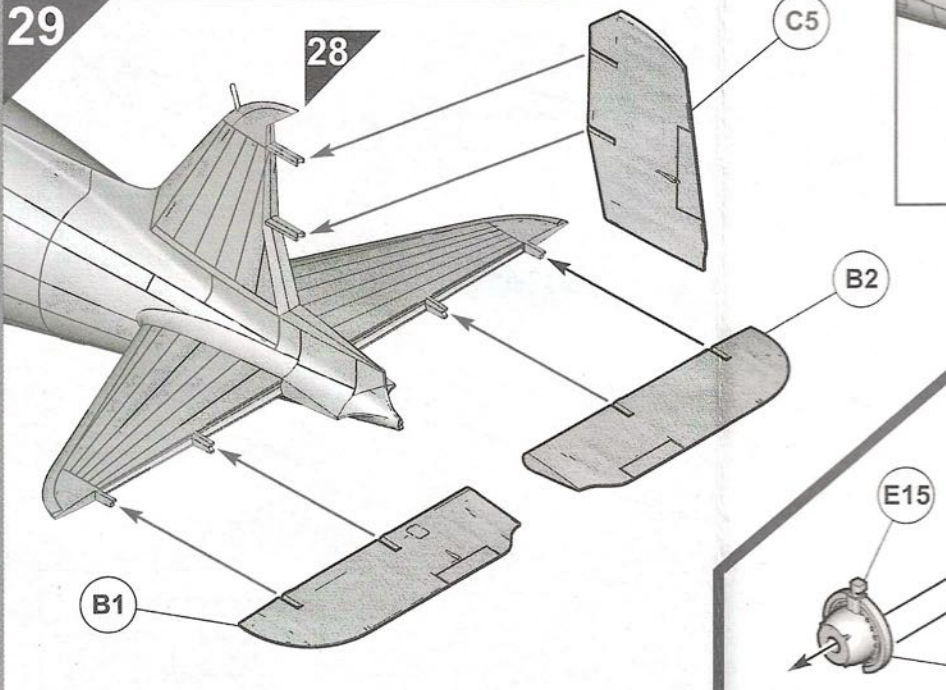
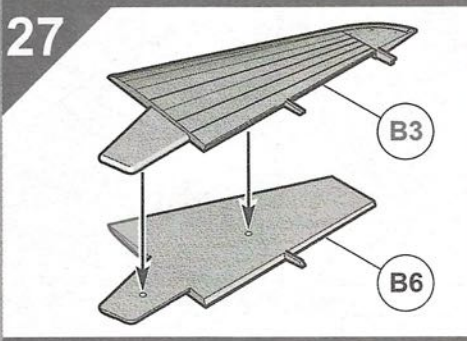
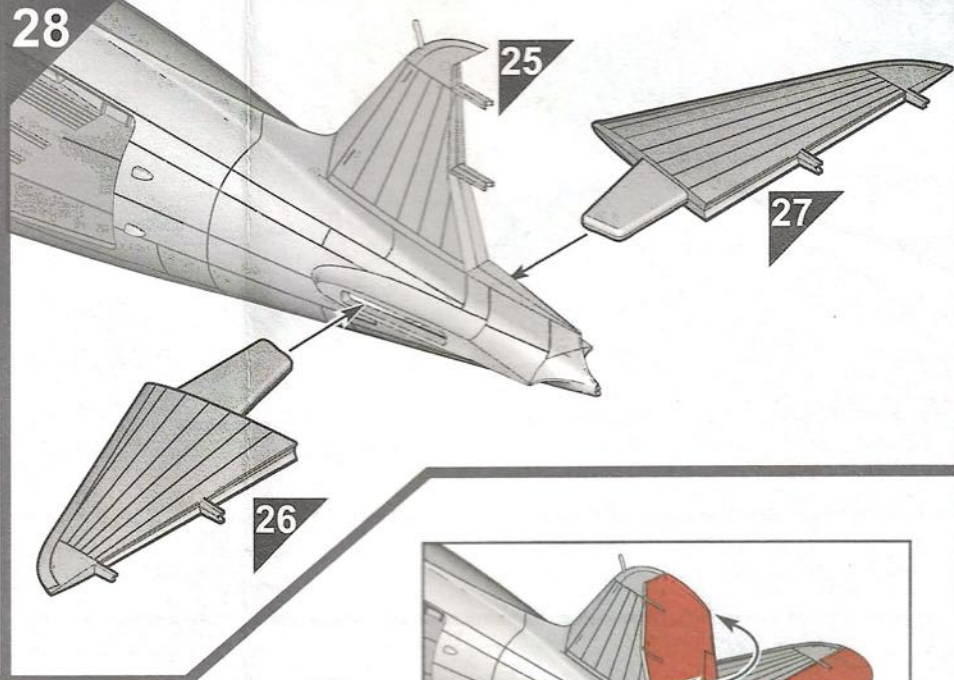
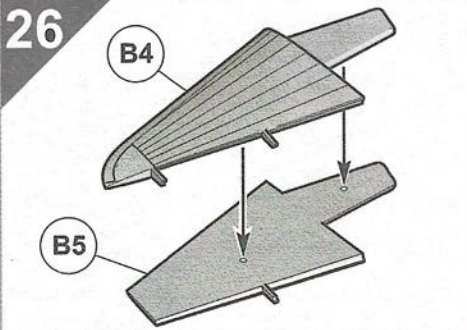

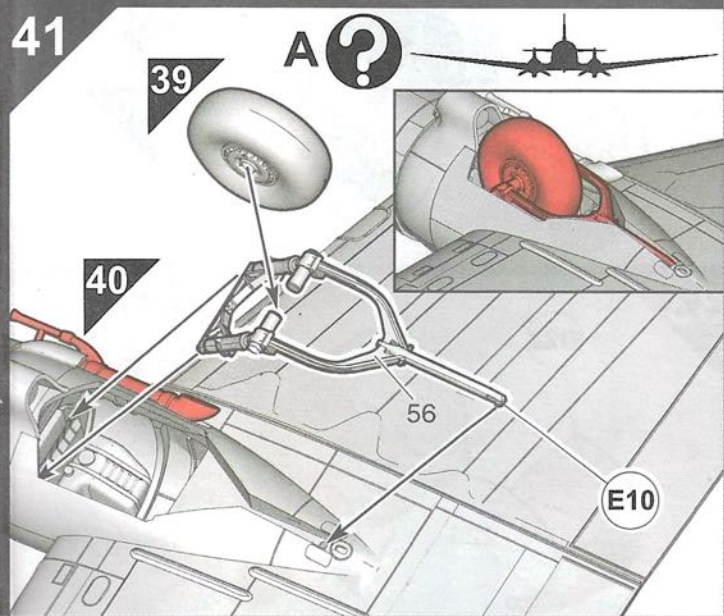
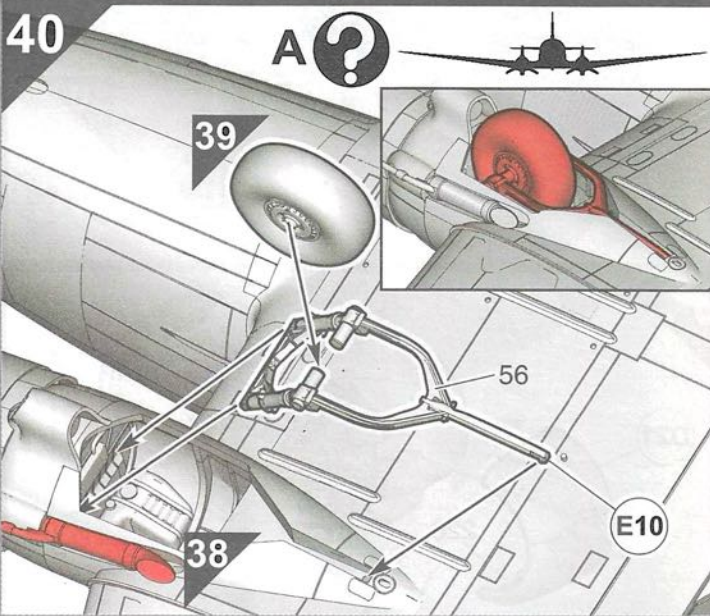
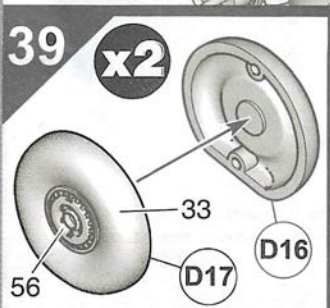
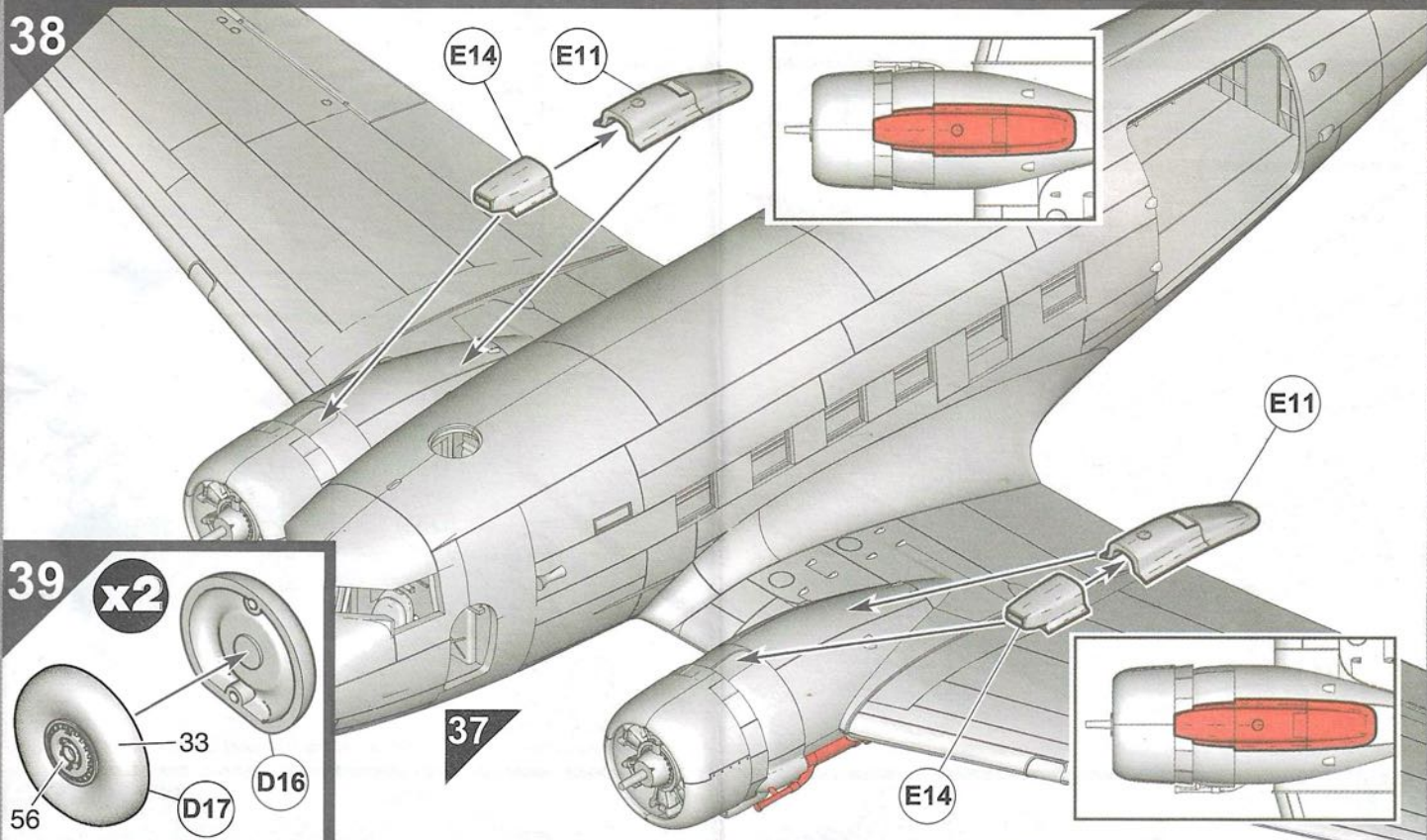
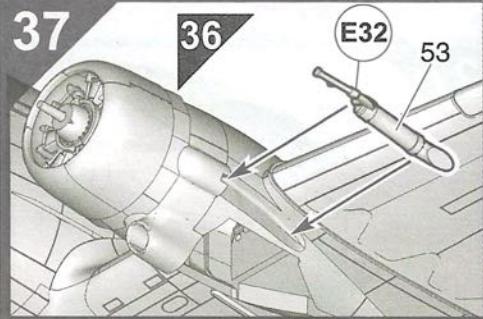
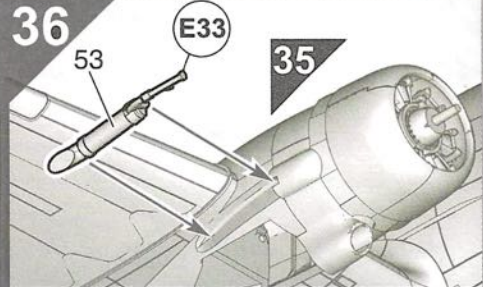
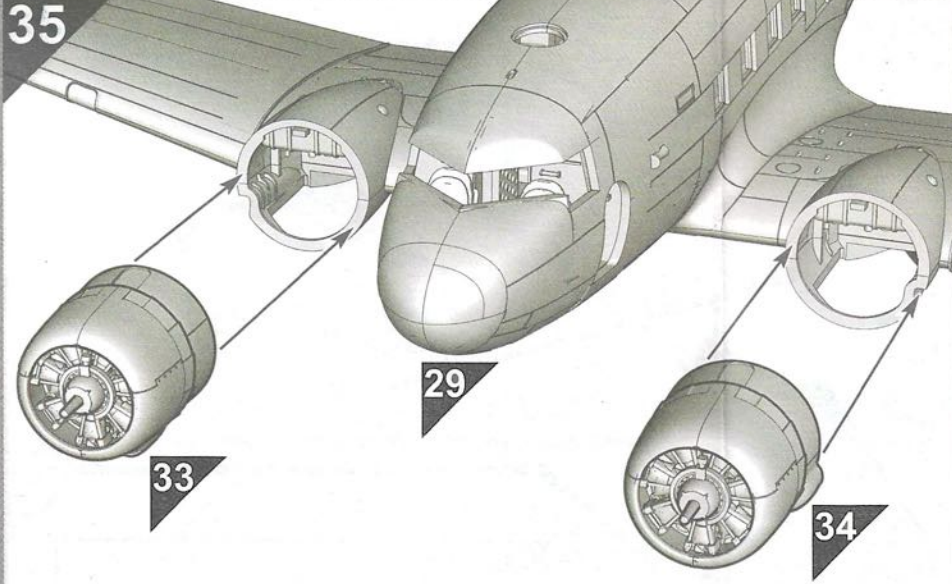

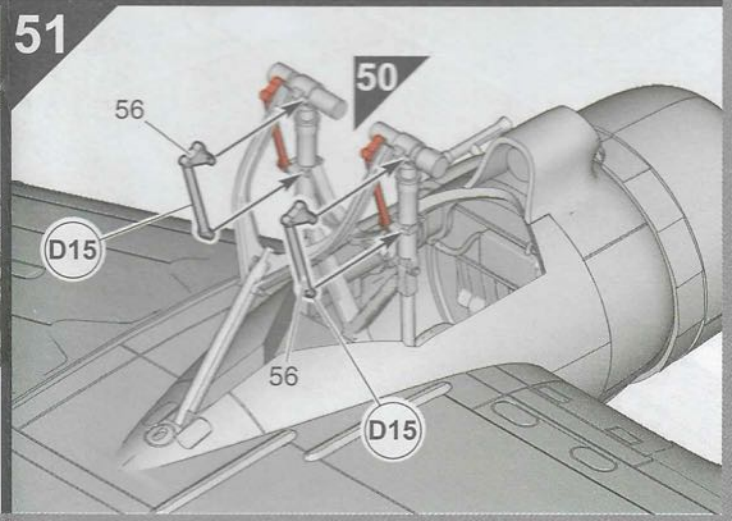
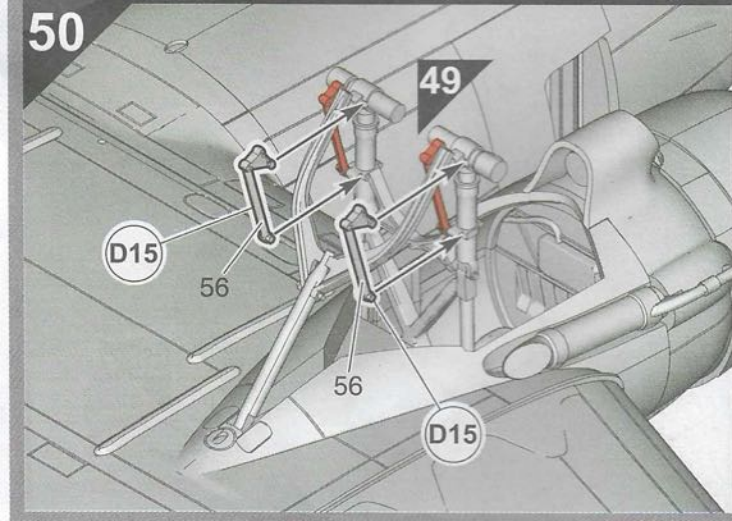
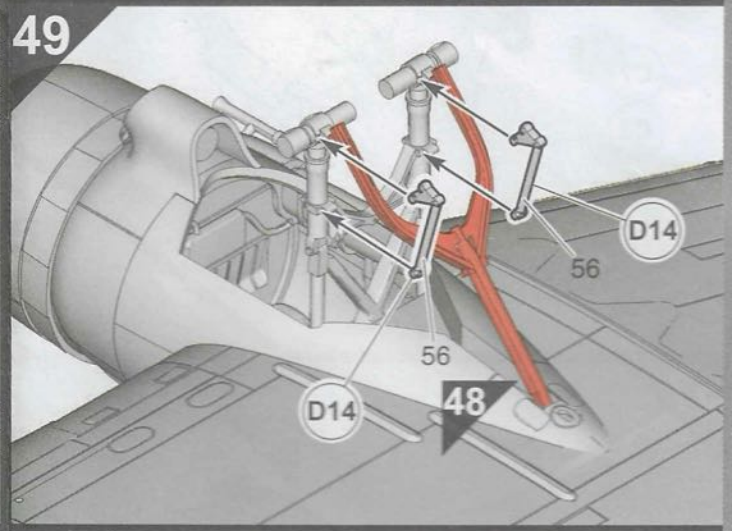
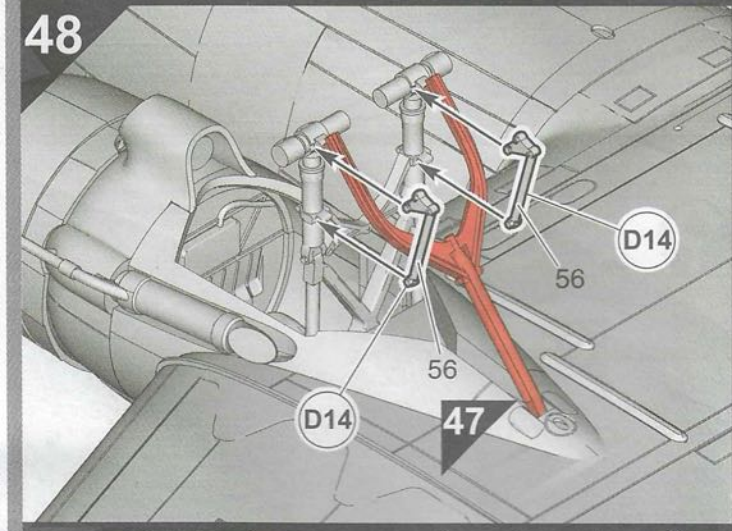
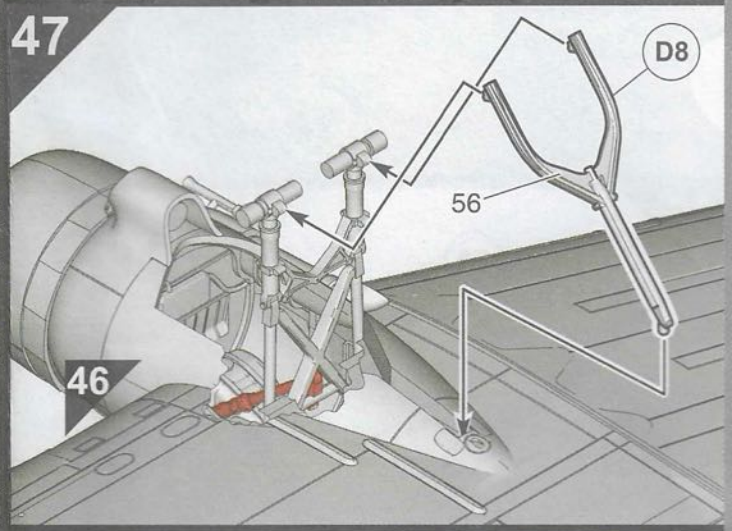
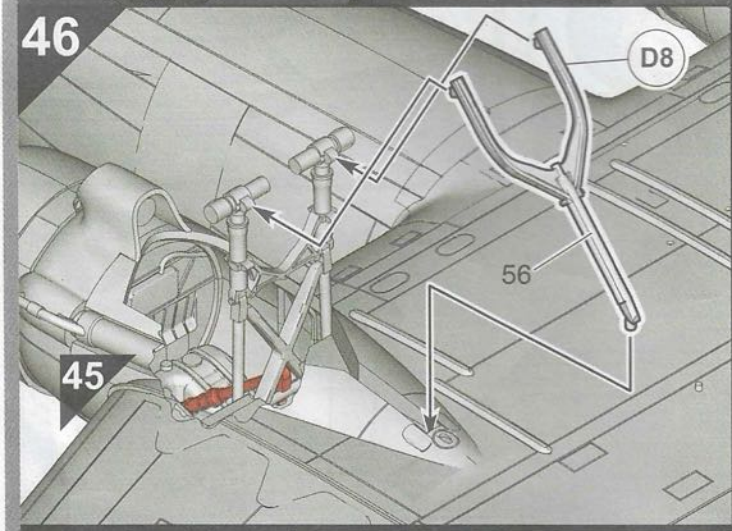
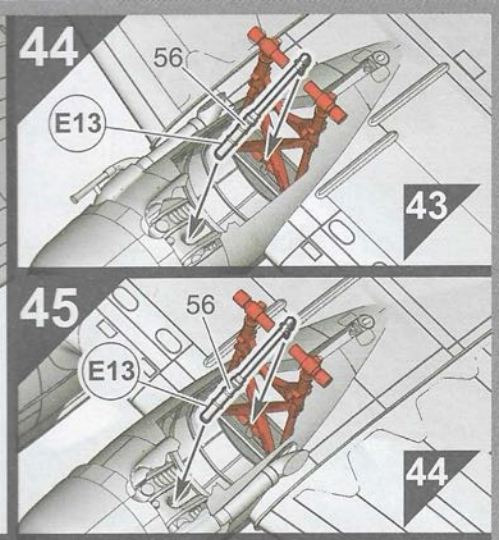
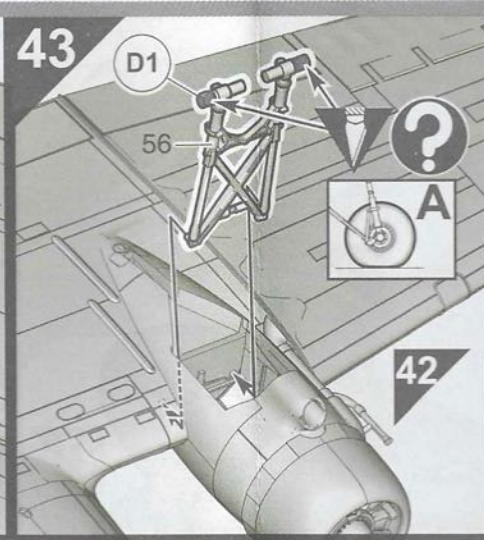
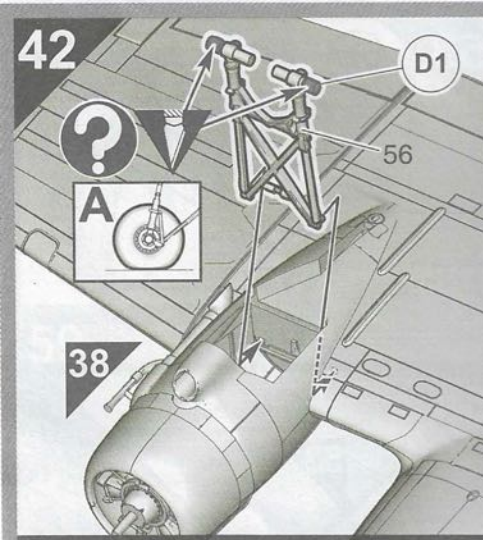



52

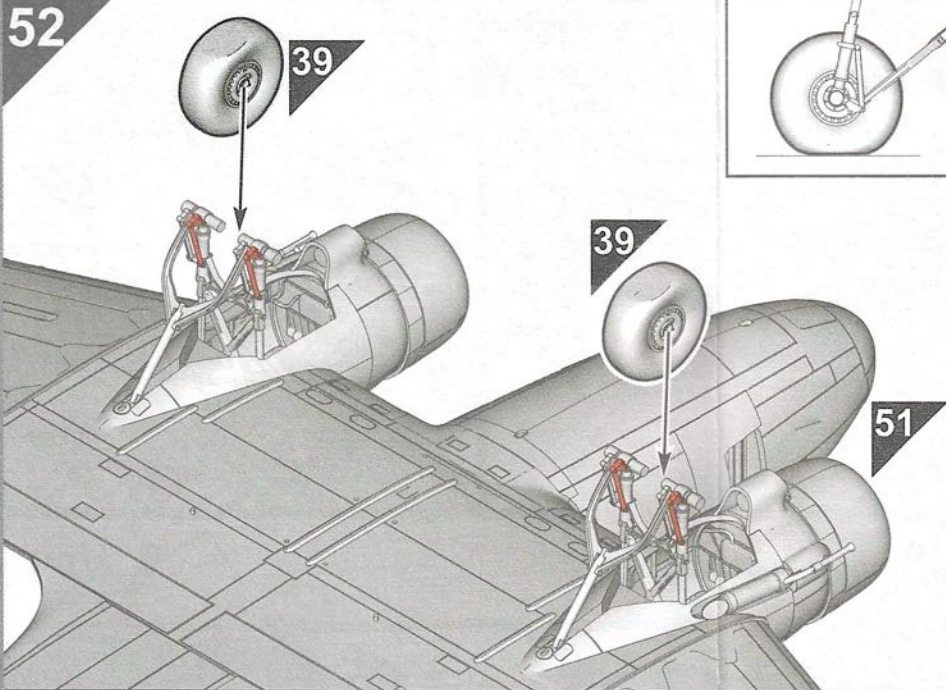

53

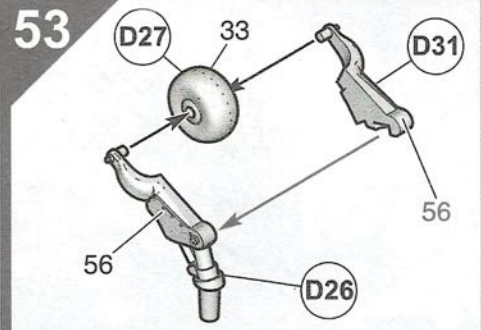
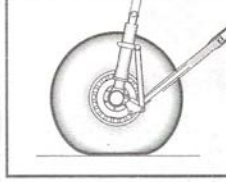

54

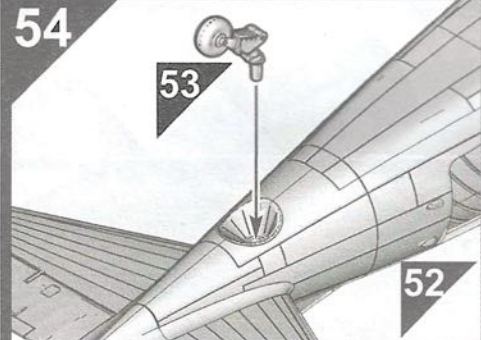

55

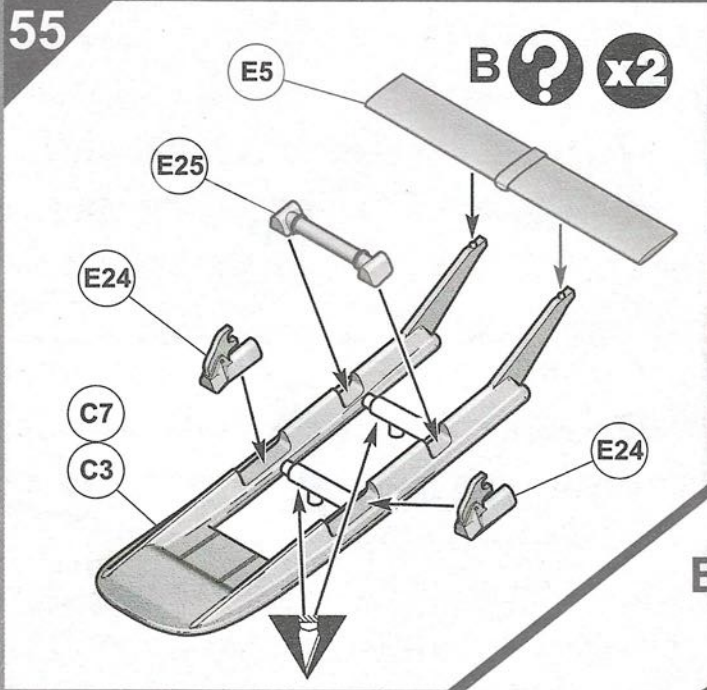

56

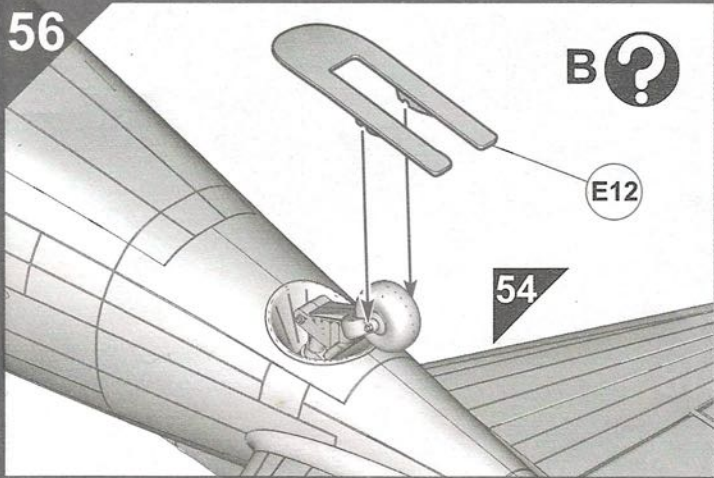

57

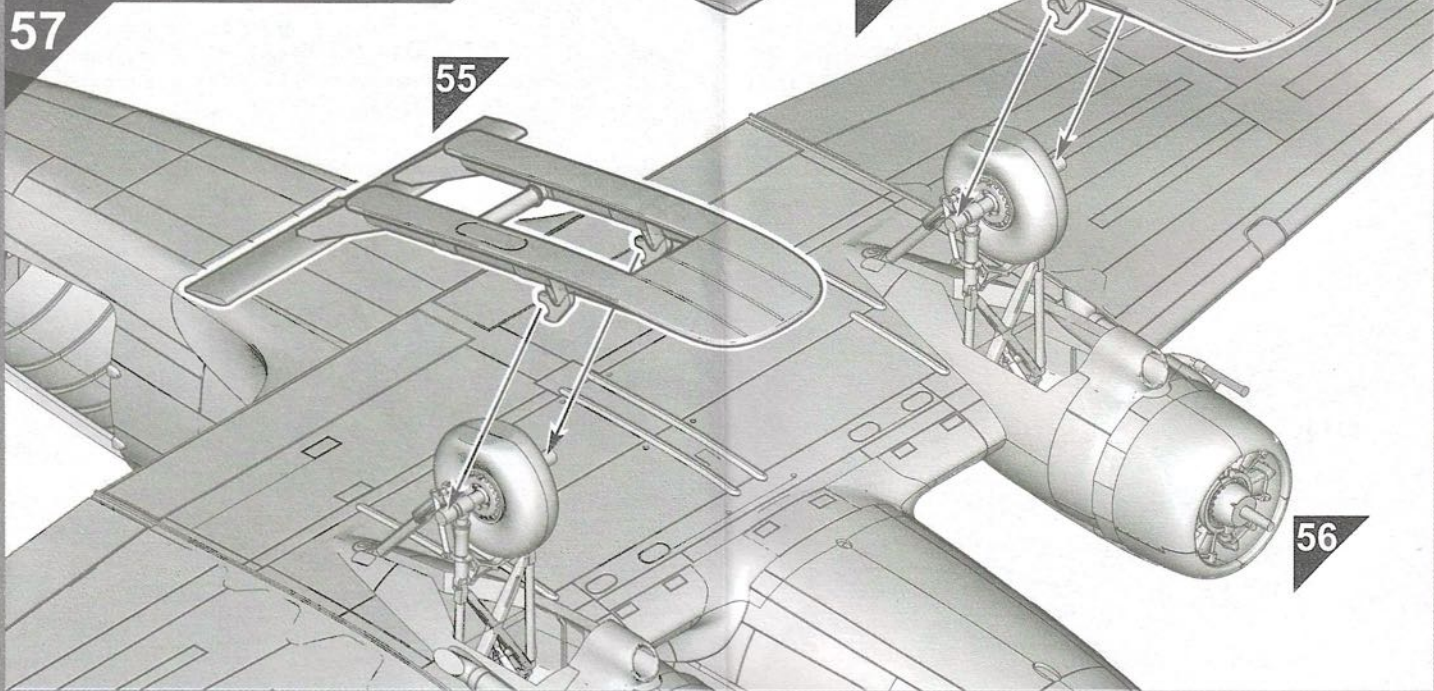

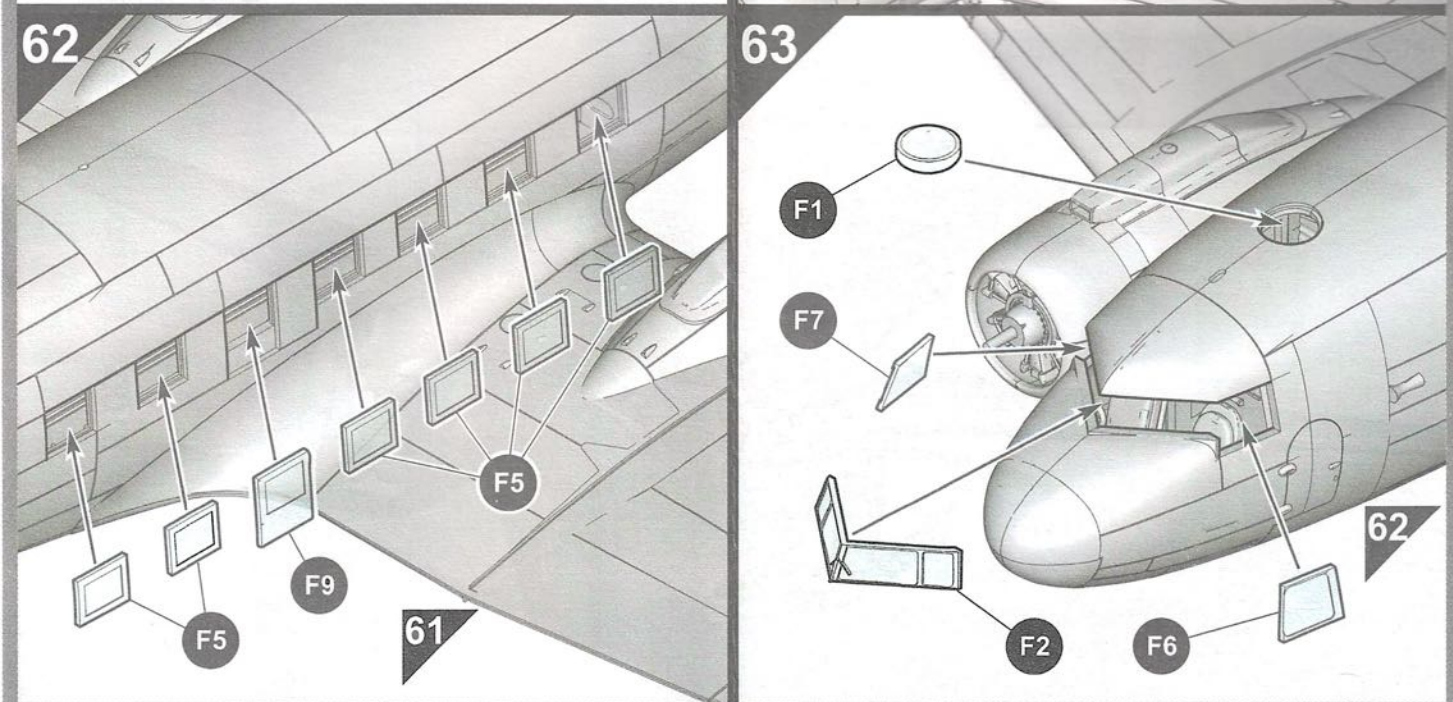
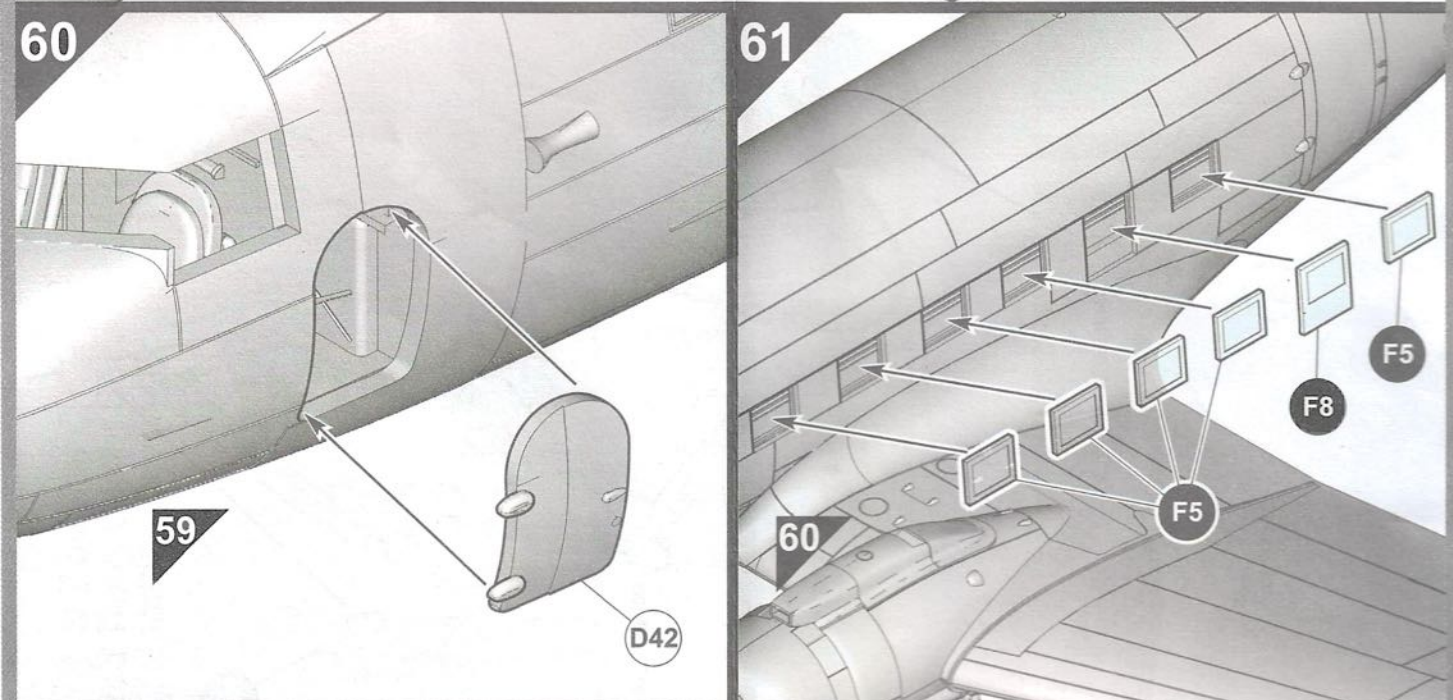
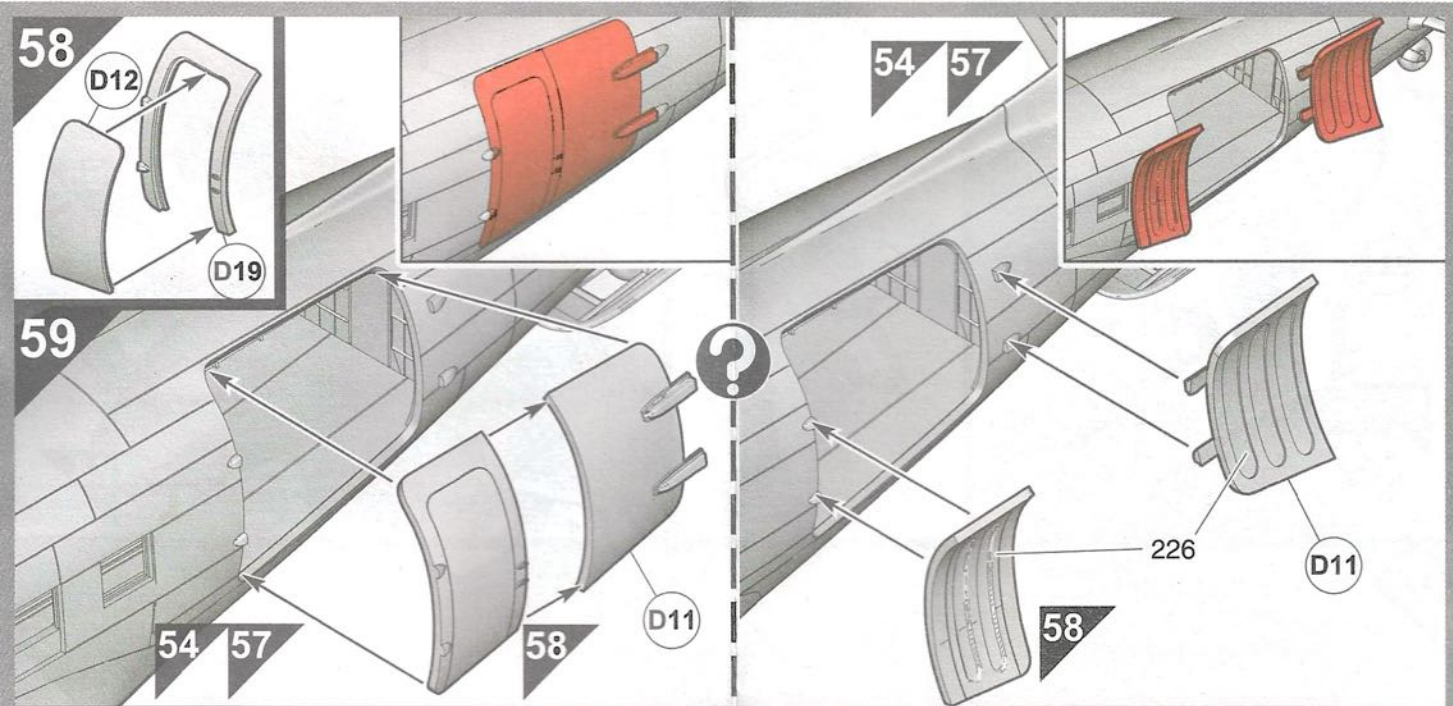

64

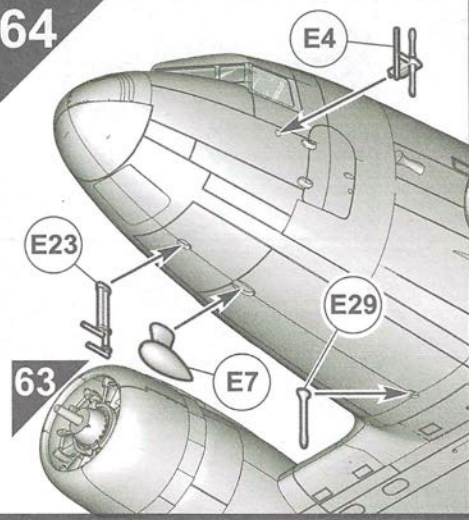

65

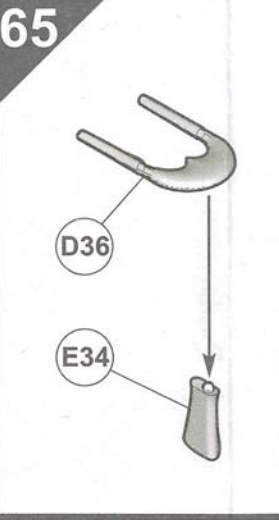

66

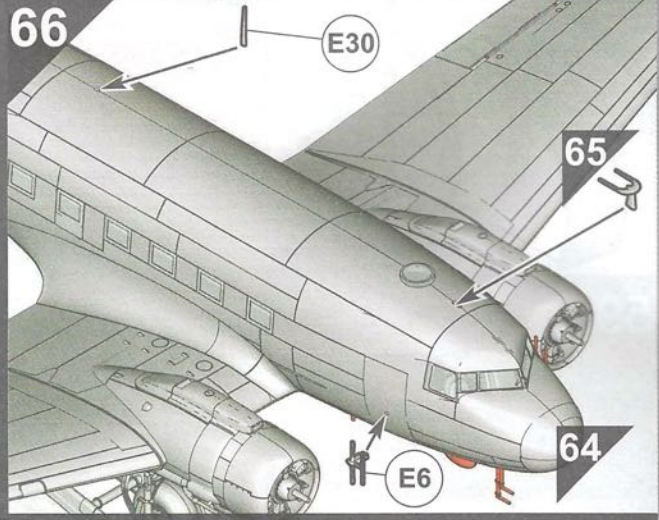

67

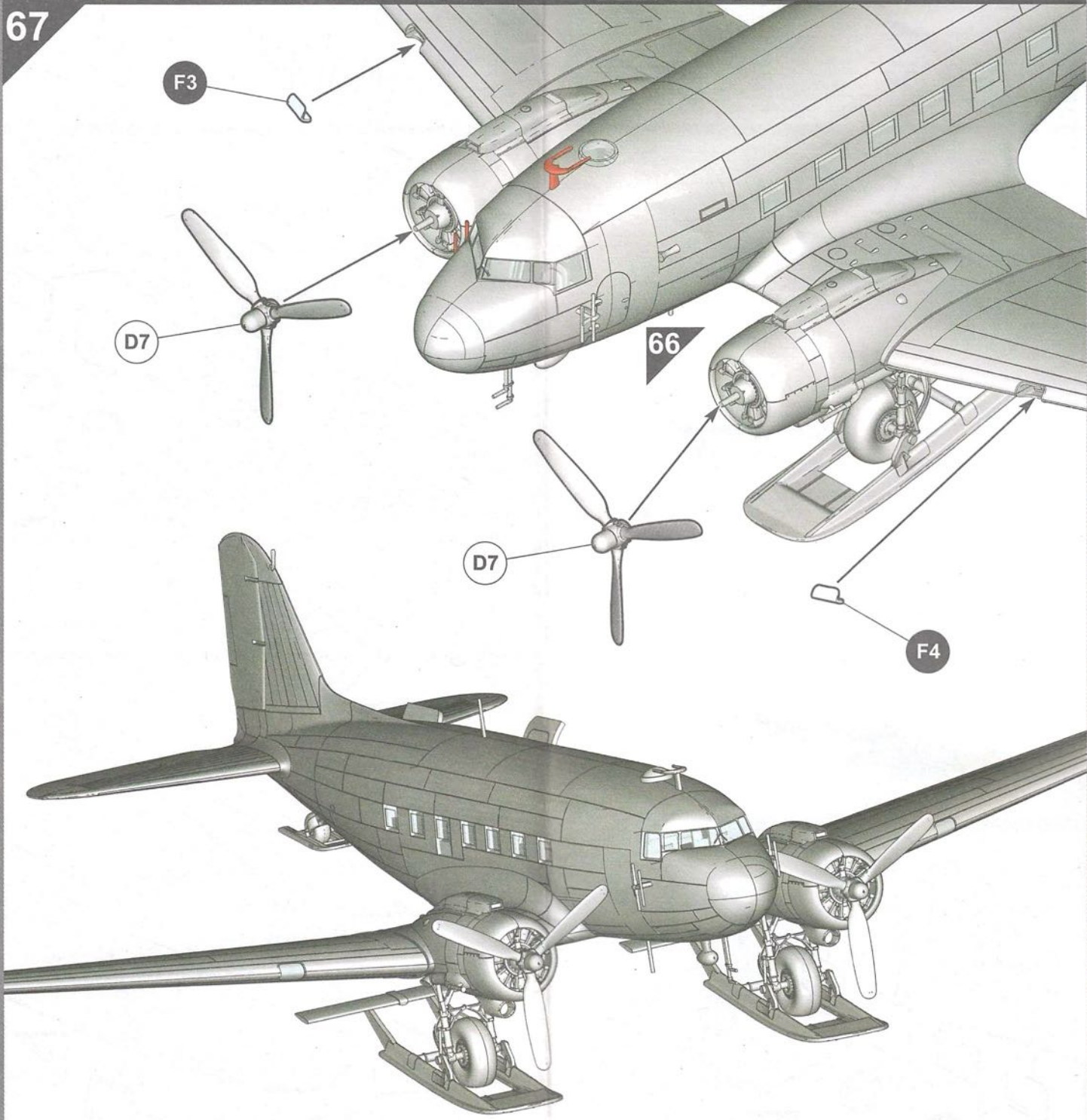

# A Douglas C-47 A-65-DL Skytrain™

41-2100521 "Kilroy is Here", 92nd Troop Carrier Squadron/439th Troop Carrier Group, Operation "Overlord", Upottery, Devon, England, 6th June 1944.

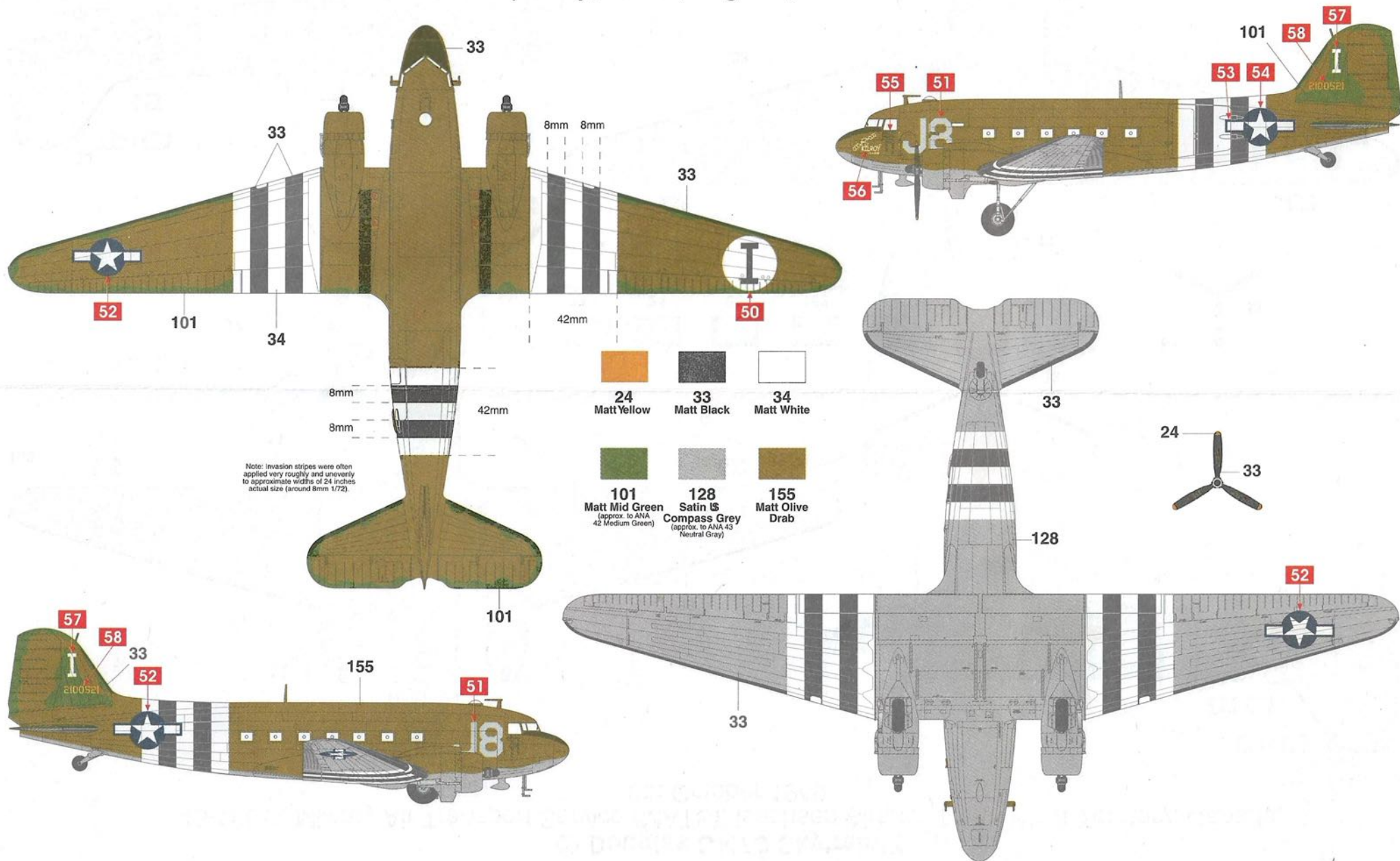

**B Douglas C-47D Skytrain™**

43-16062 Military Air Transport Service (MATS), Isachsen Airstrip, North West Territory, Canada, 9th October 1949.

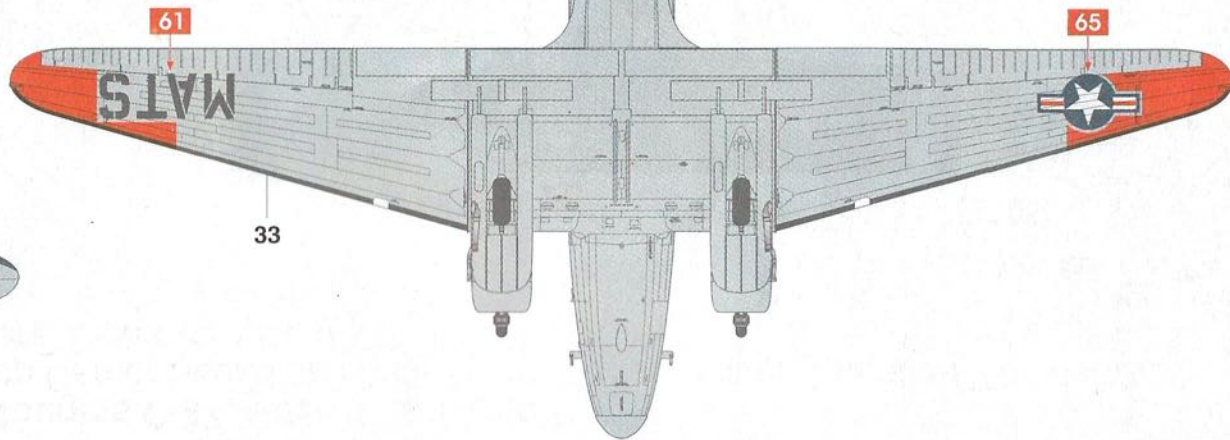
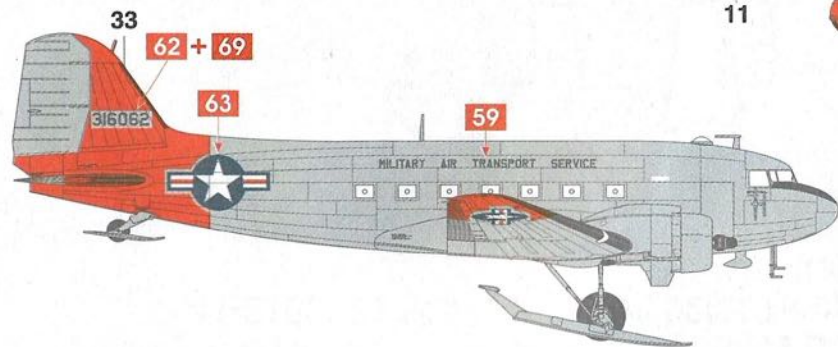
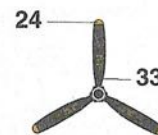
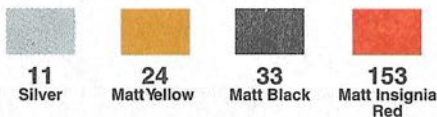
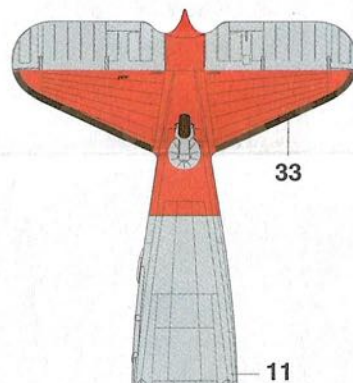
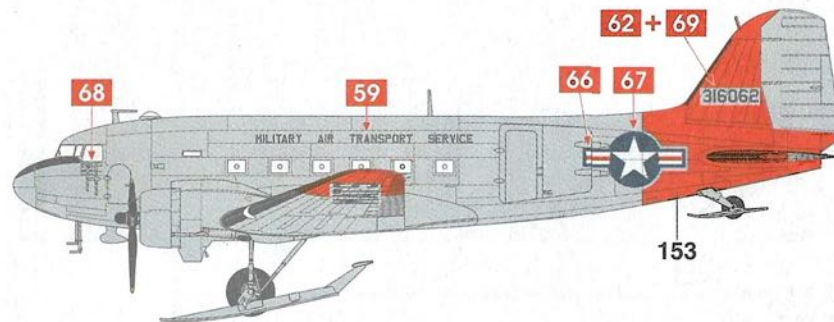
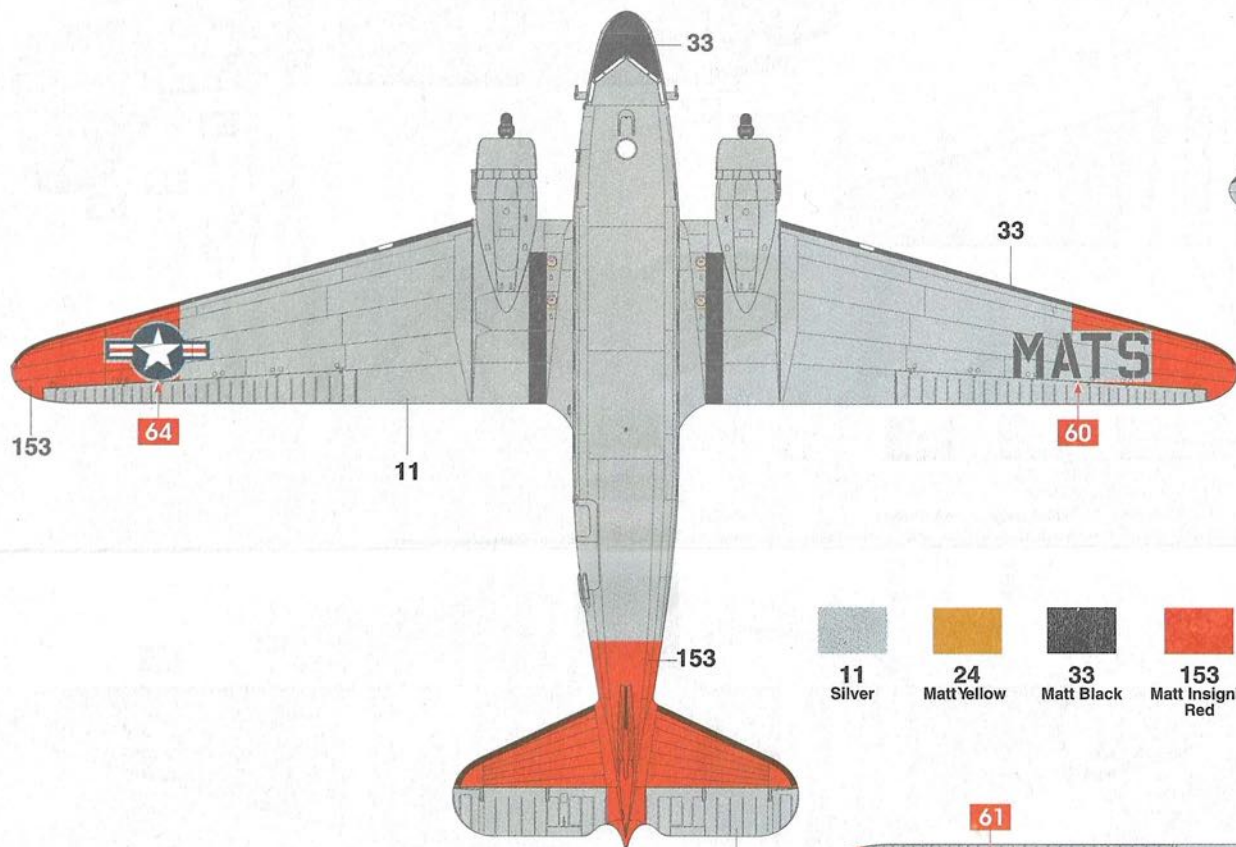

# Douglas C-47 Skytrain™

Position of common stencil data

