

WINGNUT WINGS



SE.5a 'Hisso'

1/32 Scale

When the 150hp V8 Hispano-Suiza 8Aa powered RAF SE.5 (Royal Aircraft Factory Scout Experimental 5) first appeared over the front lines in early April 1917 with 56 Sqn it was to mixed reactions though it soon proved itself in combat. The large canopy type windshield proved most unpopular and was removed almost immediately at Squadron level. Later production SE.5 incorporated this change, shorter span wings and several lesser alterations. The final few SE.5 built in July 1917 were fitted with more powerful 200hp Hispano-Suiza 'Hisso' 8Ab engines, effectively creating the SE.5a standard and it was pretty much in this form that they soldiered on to the end of the Great War 15 months later.

Problems with supply and reliability of the 200hp 'Hisso' engines dogged the SE.5a throughout its service and led to a dizzying array of engines from Hispano-Suiza and Wolseley (mostly improved 'clones' of Hispano-Suiza designs) being installed. The two significant differences were the earlier 'geared' types, where the propshaft was driven by a reduction gear off the crankshaft (the propeller has a higher thrust line and rotates counter clockwise- from the pilots perspective) and the later 'direct drive' types (with a lower propeller thrust line and rotating clockwise). As Hispano-Suiza supplied most of the early engines and they were mostly of the geared type, 'Hisso' has become how these early geared engine powered SE.5a have colloquially become known, whether their engines were manufactured by Hispano-Suiza or Wolsley. Eventually the reliable direct drive Wolsely Viper (again an improved clone of a Hispano-Suiza design) was settled on as the preferred engine. Just as SE.5as with geared engines have been identified as 'Hisso' powered, direct drive engined aircraft have become 'Viper' powered, whether they were powered by the Viper or a direct drive Hispano Suiza.

A significant feature of the SE.5/SE.5a was the rather large dihedral applied to the wings. While this meant that the SE.5a was never going to be as great a dogfighter as its contemporary, the highly agile (and lethal) Sopwith Camel, it provided a stable gun platform and was popular with both novice and experienced airmen alike. This stability also made changing the Lewis gun magazines in flight a slightly less harrowing exercise that it would otherwise have been.

While there is little controversy about the common colour scheme for the SE.5a, of PC10 (Protective Covering number 10) for the upper surfaces and CDL (Clear Doped Linen) wing lower surfaces, there is a great deal of controversy as to what colour PC10 actually was. Made from mixes of yellow ochre, iron oxide and lamp black pigments it varied between chocolate brown and olive drab, depending on the mix and, presumably, time spent exposed to the elements. It appears that early, fresh, PC10 appeared more olive drab (XF62) while later mixes and aircraft exposed to the elements for some time would appear more chocolate brown (our suggested mix). Metal cowling panels were left unpainted on the interior and usually painted PC10 on the exterior, though sometimes they were left completely unpainted.

Wingspan:	Length:	Max Weight:	Max Speed:
26' 7" (8.1m)	21' (Hisso) - 20' 11" (Viper)	2048lb (929kg)	121mph/15000ft (195kph/4572m)
No. manufactured:	Production:	Engine:	
5225 (including 77 SE.5)	Sept. 1916 to Oct. 1918	200hp Hispano-Suiza & Wolseley Viper	
Armament:			
.303"(7.7mm) Lewis gun on upper wing and .303 (7.7mm) Vickers gun in fuselage. Up to 100lb (45.5kg) of bombs.			
References:			
The SE.5 File, Ray Sturtivant & Gordon Page, Air Britain, 1996 - RAF SE.5a, J.M.Bruce, Windsock Datafile Special, 1993 RAF SE.5a, J.M.Bruce, Windsock Datafile, 1989 - SE.5a in Action, John F Connors, Squadron Signal, 1985 - Private Collections SE.5a, Charles Bourget, WW1 Aero Publishing Inc, 1966 - http://thevintageaviator.co.nz - 1914-18 Aviation Heritage Trust			

SE.5a 'Hisso'

1/32 Scale













Warning: Choking hazard. Keep small parts and plastic bags away from children. Use glue and paint in a well ventilated area. Always wear protective eyewear when cutting and a protective mask when painting, gluing and sanding. Do not breathe dust from polyurethane resin parts (if included). Beware of sharp edges on metal parts.

Assembly: Read all the instructions carefully before starting assembly. Use glue intended for plastic models. Assemble metal and resin parts (if included) using Cyanoacrylate (CA) or epoxy glue. Before assembly select a marking option and note optional parts required in instructions.

Painting: Only use paints suitable for plastic model kitsets.

Decals: Cut out each decal as required. Soak in warm water for 15 seconds. Slide off backing paper onto gloss painted surface of model. For large decals it is helpful to apply a drop of water to the area they are being applied to. This will make it easier to maneuver them into the correct position

SYMBOLS

 Construction Step	 Choose	 Attention	 Remove
 Part Number	 Do Not Cement	 Option	 Drill
 Decal	 Cement For Metal	 Other Side	 Paint Colour
 Photo Etch Part			

PAINT COLOURS

	All colours	Tamiya	Humbrol	Misterkit
a	Brass	X31	54	
b	Copper	XF6	12	
c	Gun Metal	X10	27004	
d	Aluminium	XF16	27001	
e	Steel	XF56	27003	
f	Light Wood	XF59	93	
g	Rust	XF9	113	
h	Leather	XF52	62	
i	Clear Doped Linen	XF55	121	BC05
j	Semi Gloss Black	X18	85	
k	PC10	XF62(x2) + XF10(x1)	155	BC03
l	Battleship Grey	XF53	87	BC01
m	Dark Wood	XF68	98	
n	Rubber	XF69	66	
o	White	XF2	34	

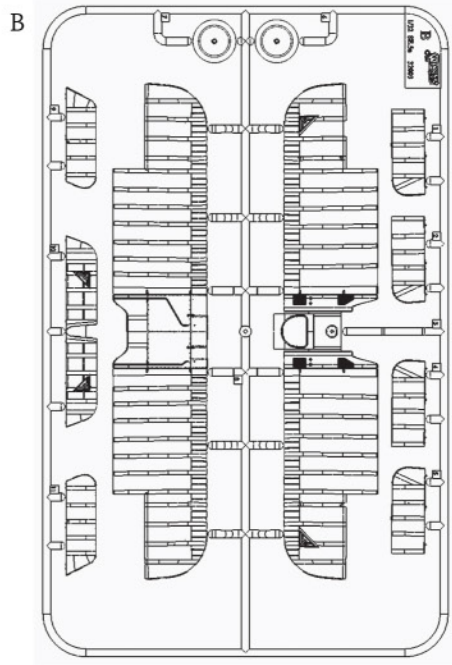
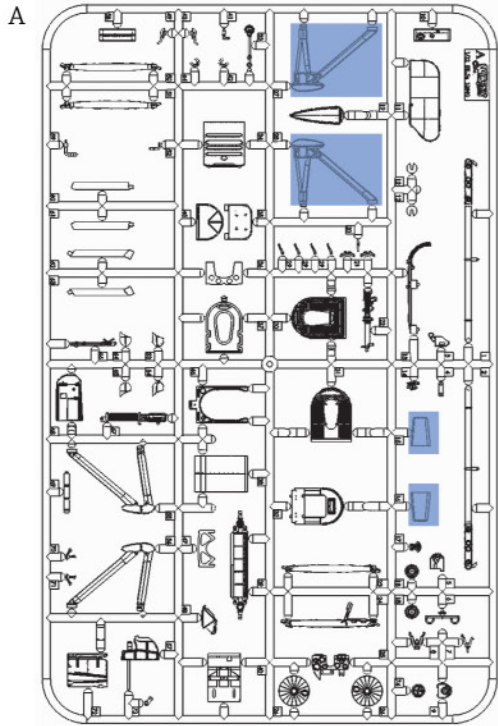

 = Not Used

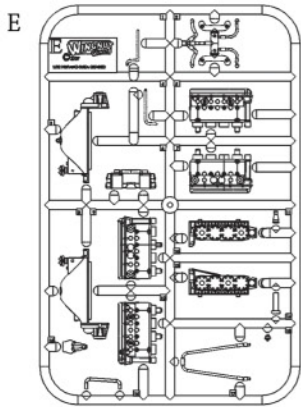
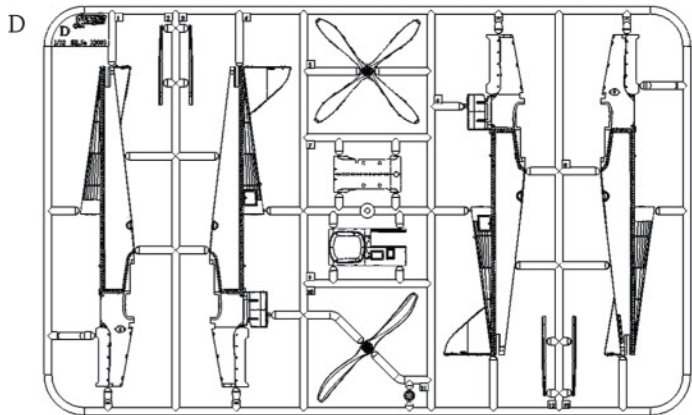
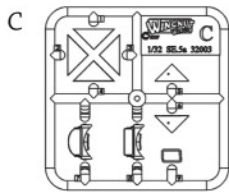

Decal Sheet

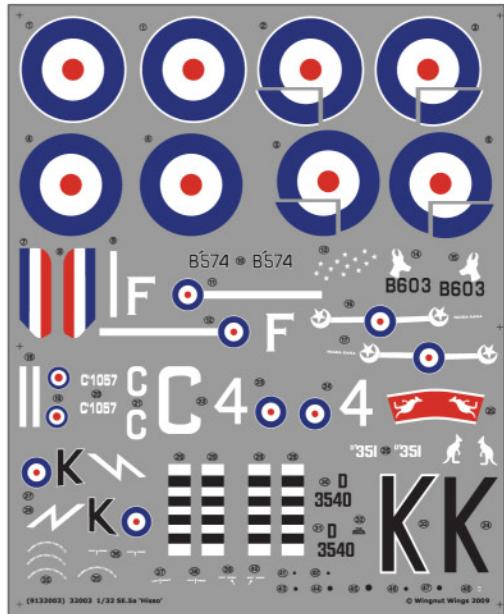
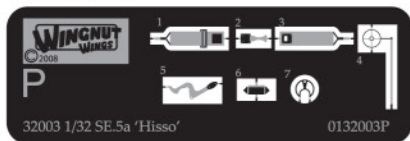
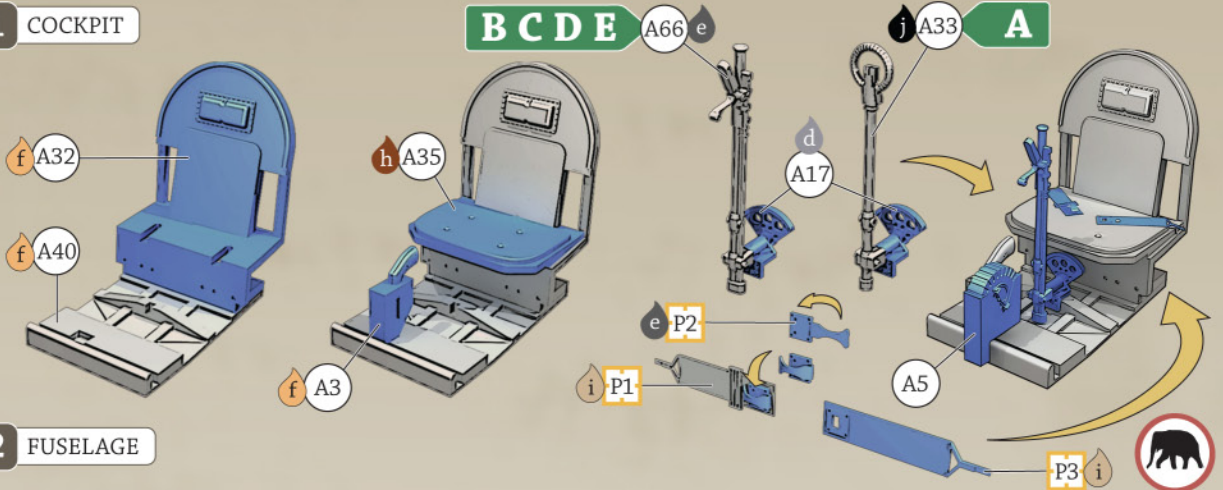

Photo Etch



1 COCKPIT



2 FUSELAGE

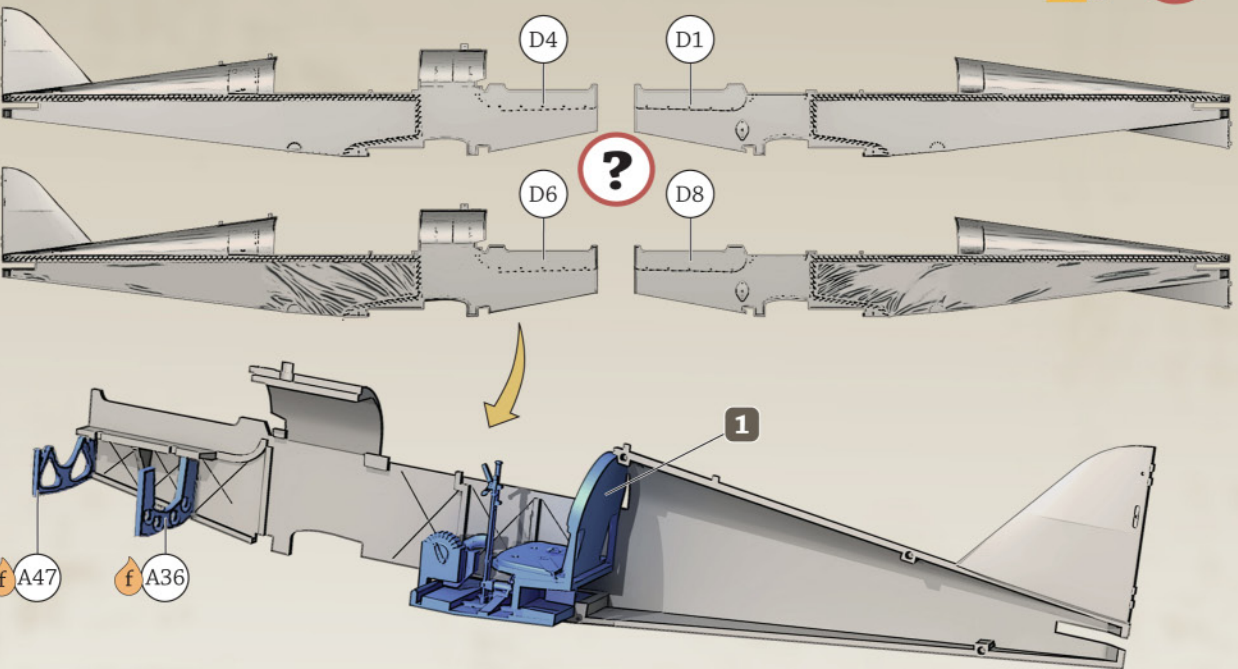

3

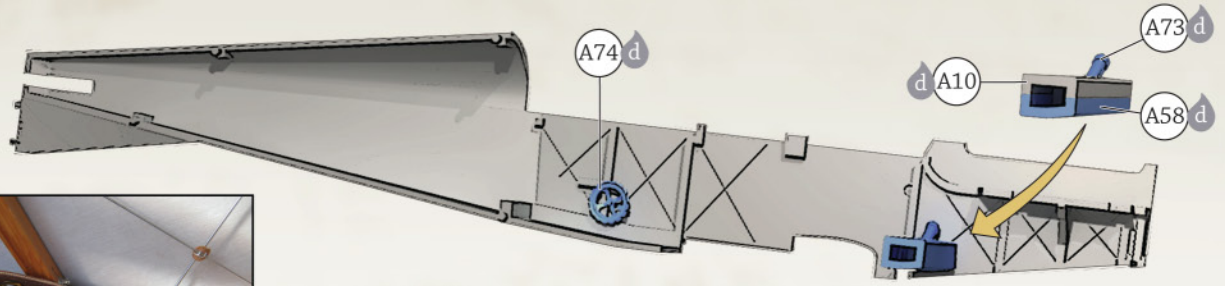

Painting Guide

Tailplane incidence adjusting wheel to the left of the pilot's seat.

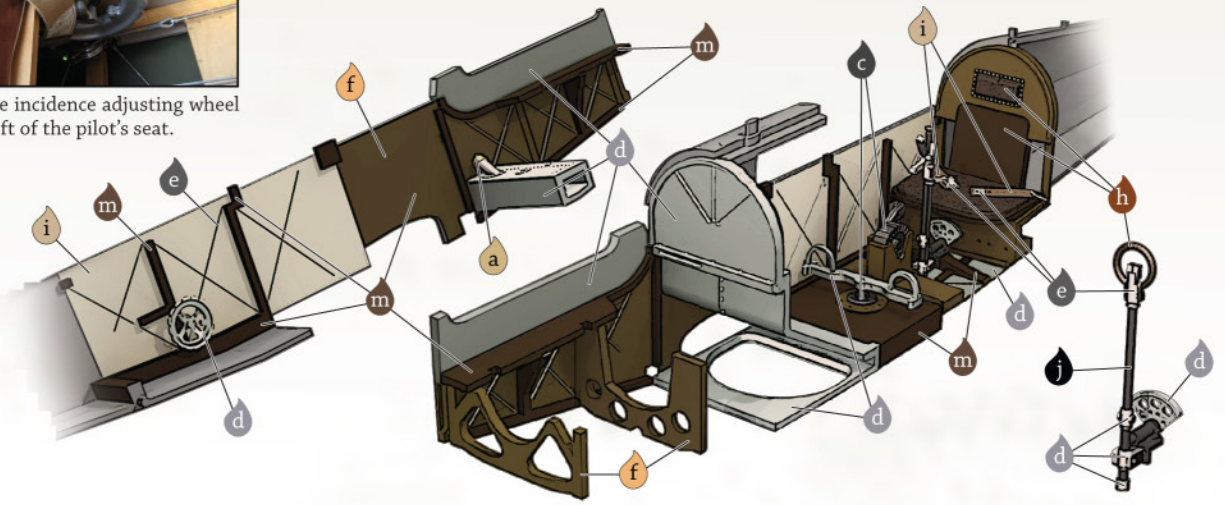

4 FUSELAGE continued

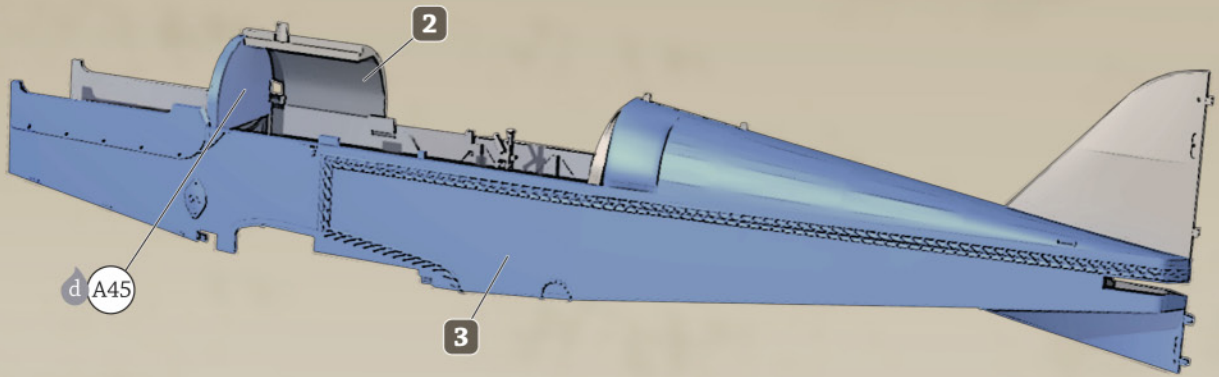

Instrument board of TVAL WA19 showing colour details of the instruments and control column. Note bare metal edging to the cockpit stiffener and the difference between the linen fuselage panel sides and plywood cockpit coaming.



Throttle and radiator shutter control levers (in line engine type).

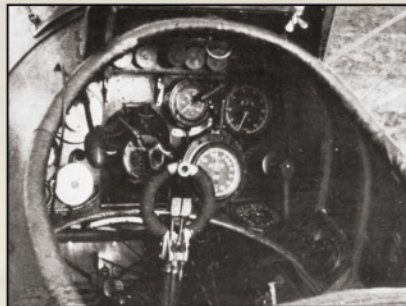

Instrument board of a wartime SE.5a showing one of the many different arrangements of instruments.



Magneto starter located to the right of the pilot's seat.

5 INSTRUMENT BOARD

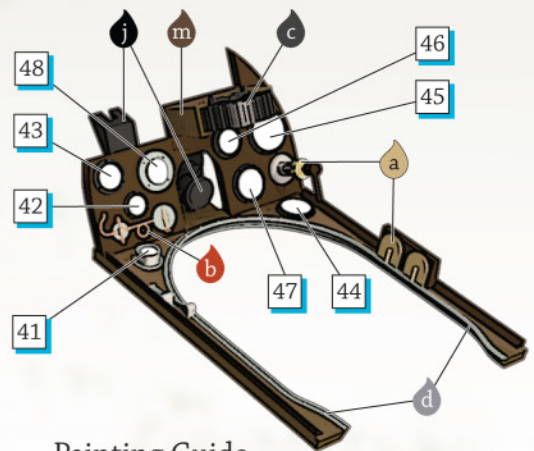
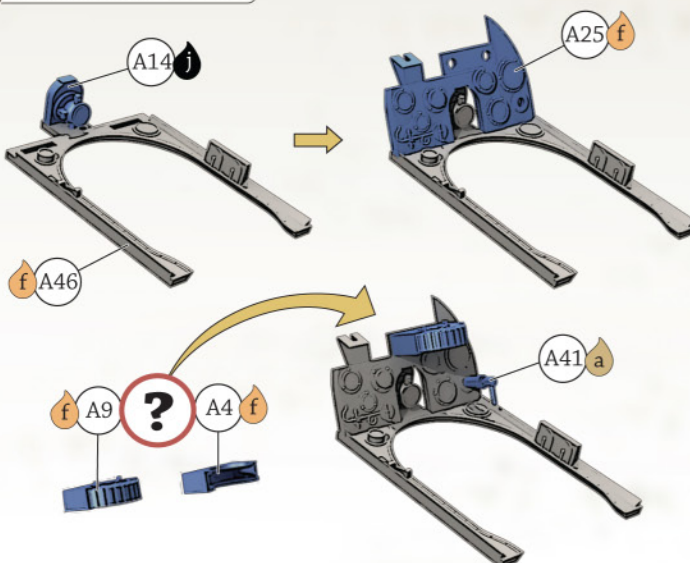

Painting Guide

6 FUSELAGE continued

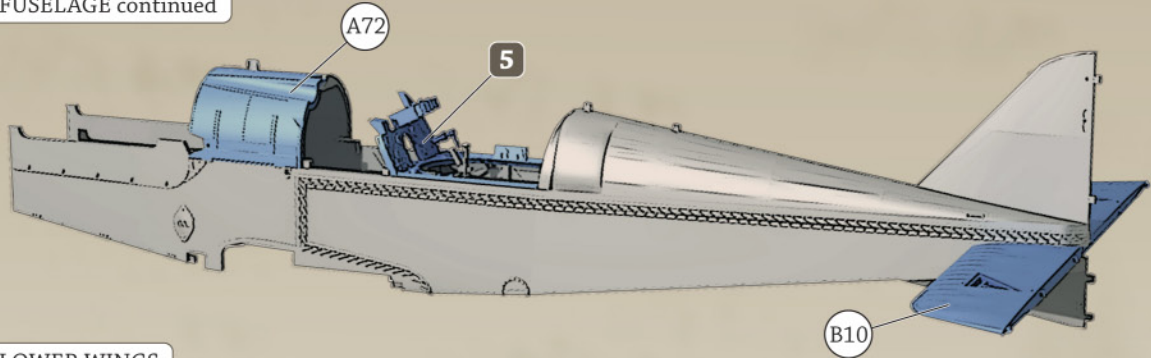

7 LOWER WINGS

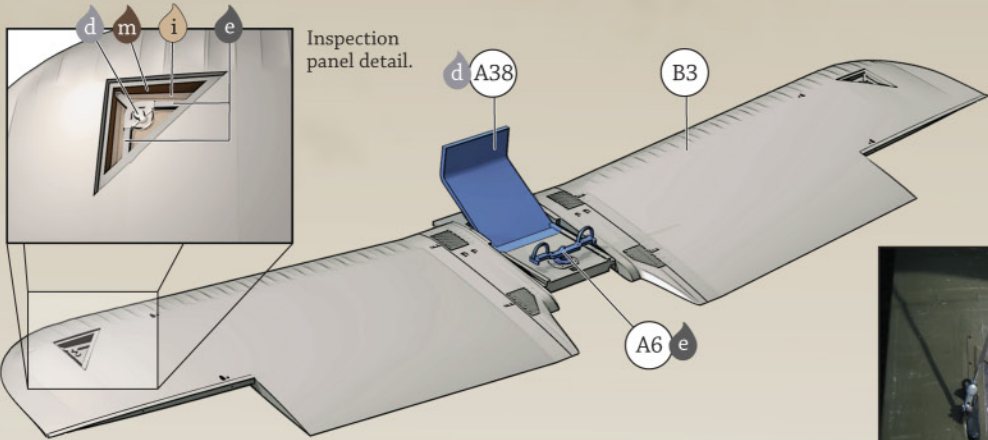

Elevator control cable pulley inspection panel detail from tailplane.

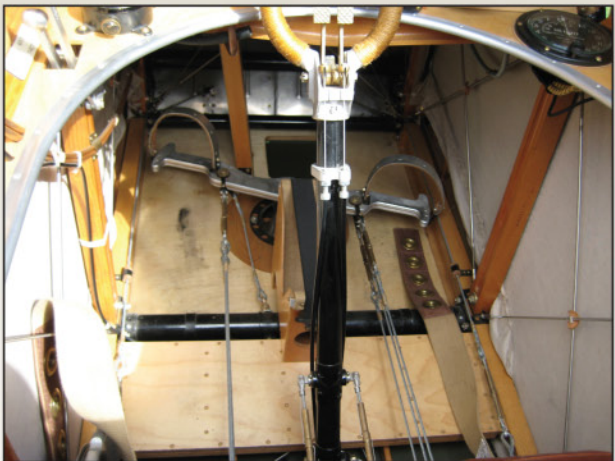
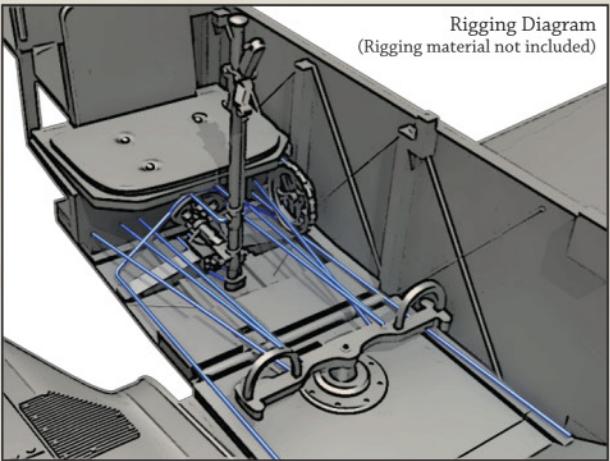

Cockpit floor of TVAL's (The Vintage Aviator LTD) superb modern build Hispano-Suiza direct drive powered SE.5A-1 WA19. Note the rudder and tail skid control cables.

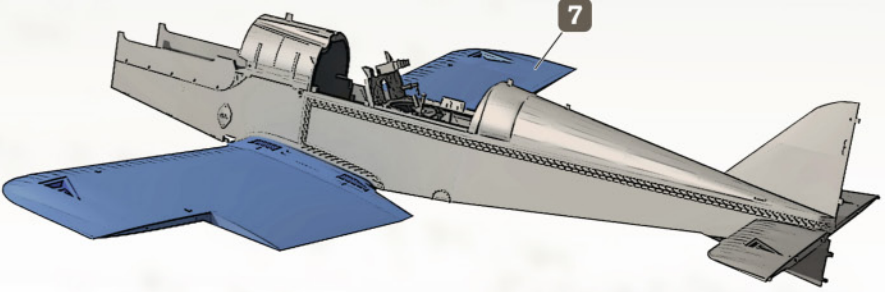

< Foot steps and lower wing root, note the wing attachment brackets.

8 FUSELAGE DETAILS

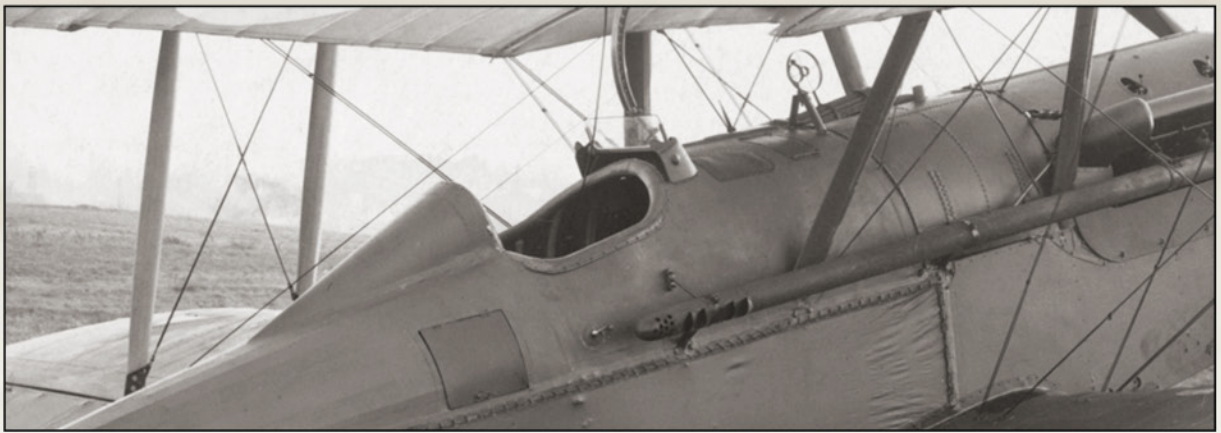
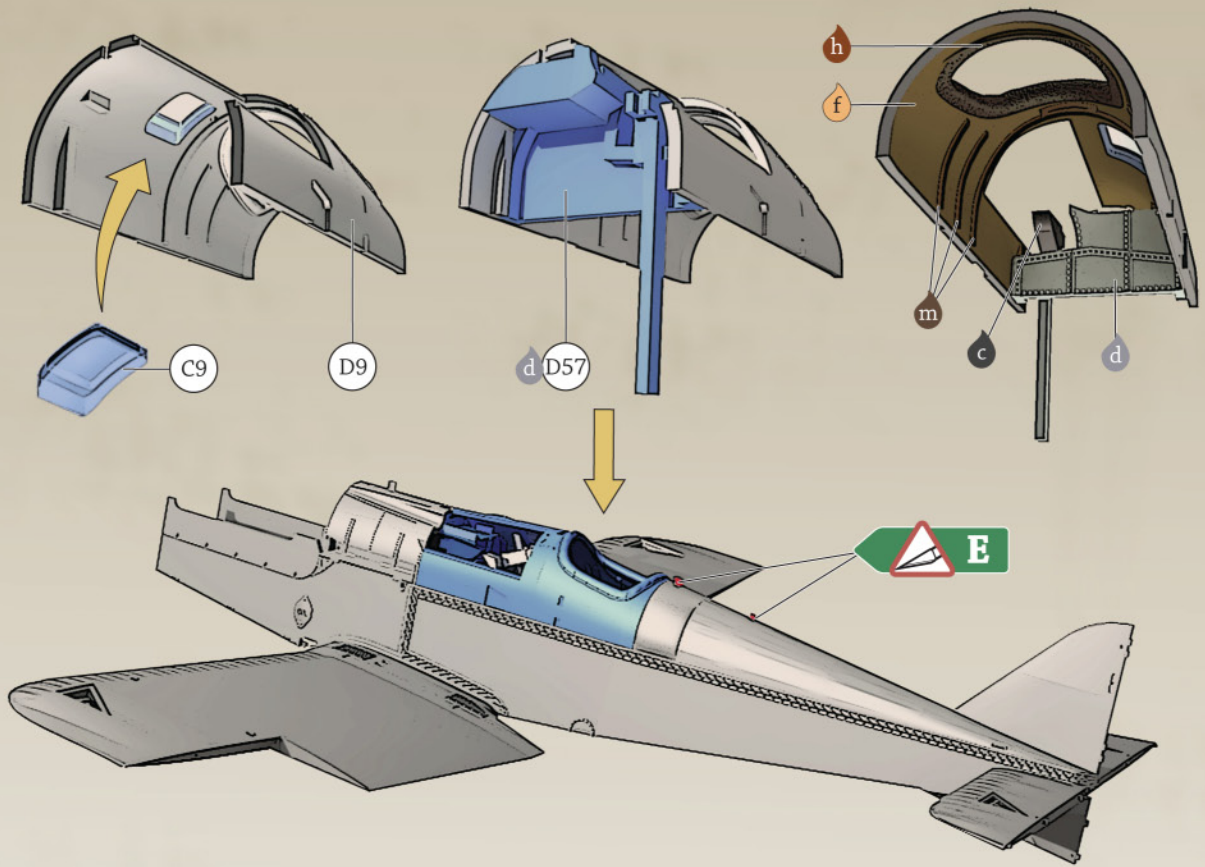

Cockpit and exhaust detail from B4897 showing the hinged locker to the rear of the exhaust. Note that the Aldis sight is not fitted in this photo.



More detail from WA19 showing Aldis sight front mount, Vickers gun magazine hatch and window to help illuminate the instrument board.



Exhaust detail from WA19. Note the subtle variations in the cockpit padding and windshield fairings from B4897.

9 FUSELAGE DETAILS continued

ACDE

Vickers Gun

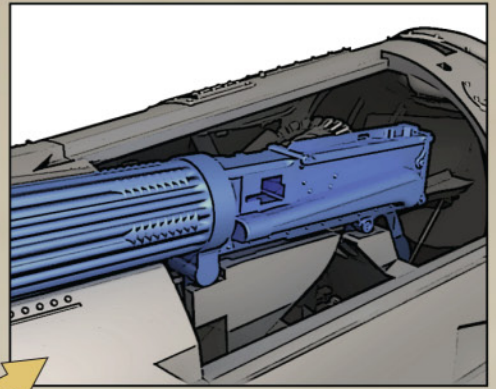
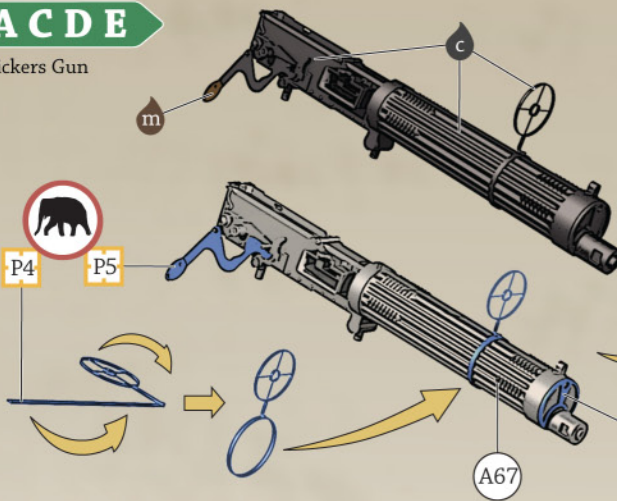

Vickers Mk.1* showing the brass breech block, muzzle details and air vents cut into the cooling jacket. Note that this gun features a Hyland type B loading handle of a different design to the Hyland type E commonly fitted to the SE.5a and featured in our model.

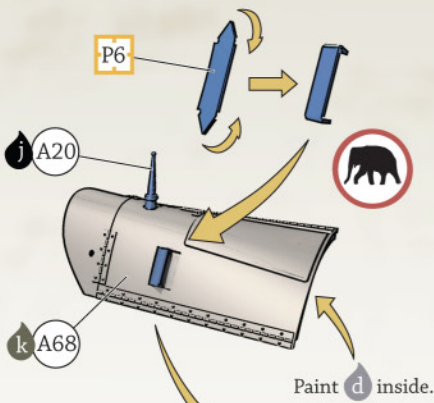

Headrest showing leather padding details. Note the four point Sutton safety harness, not usually seen on wartime aircraft.



The new owners of B574 inspect the controls of their recent acquisition.

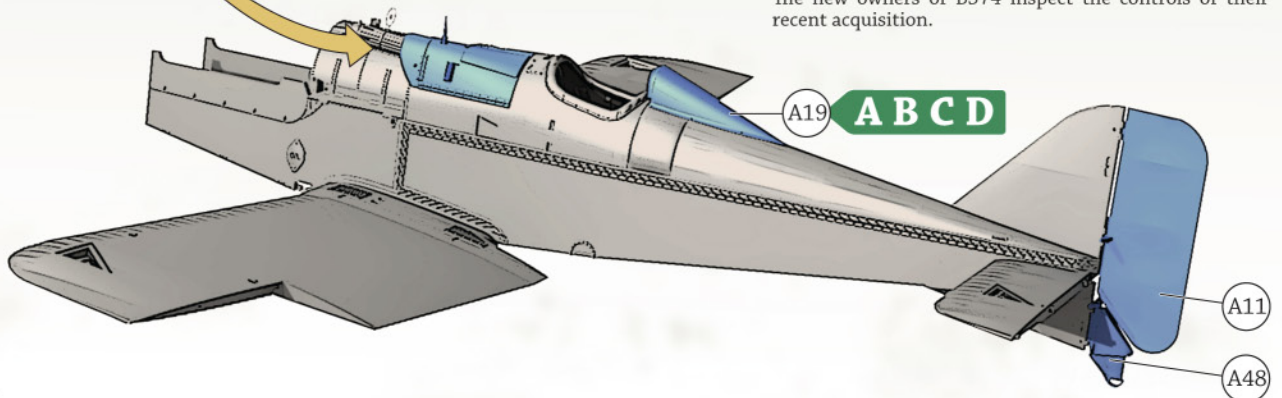

10 STRUTS AND DETAILS

ACDE

Aldis Sight

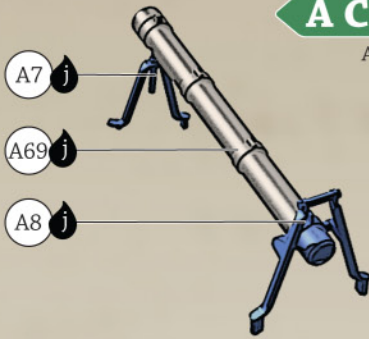

Aldis sight and windscreen details from WA19. Note the brass ends of the Aldis optical sight, the ring and bead sights and method of attaching the Foster mount brass rail to the Aldis sight bracket.

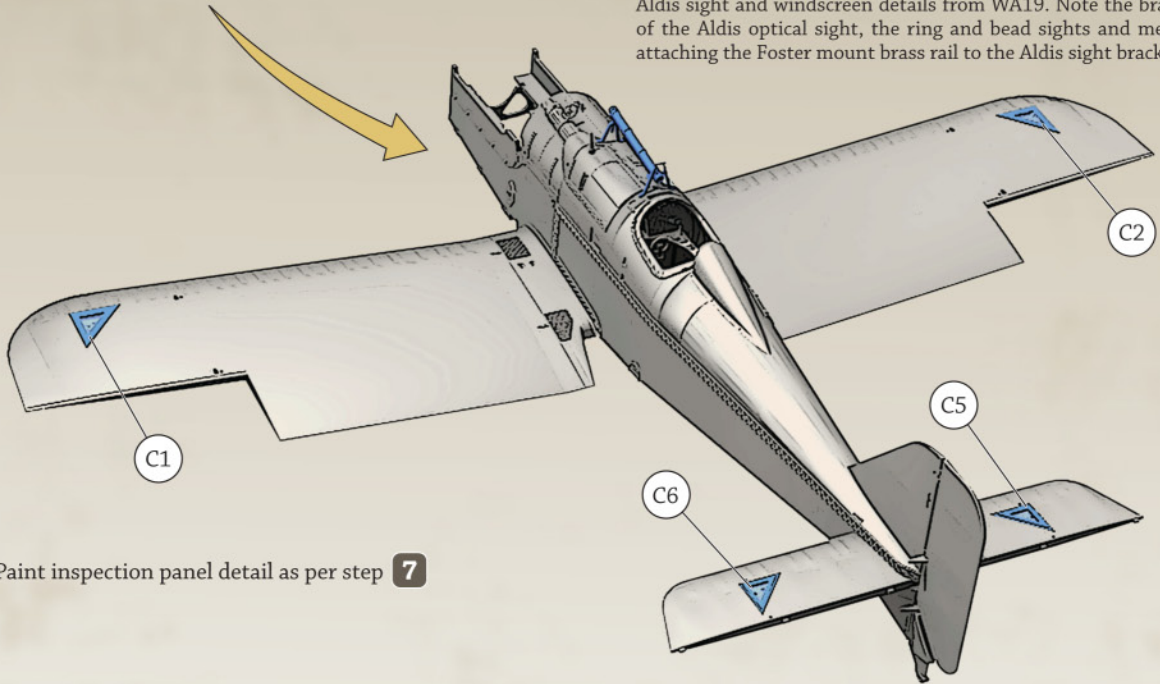

Paint inspection panel detail as per step **7**

ABD

C7



CE

Choice of Windscreens

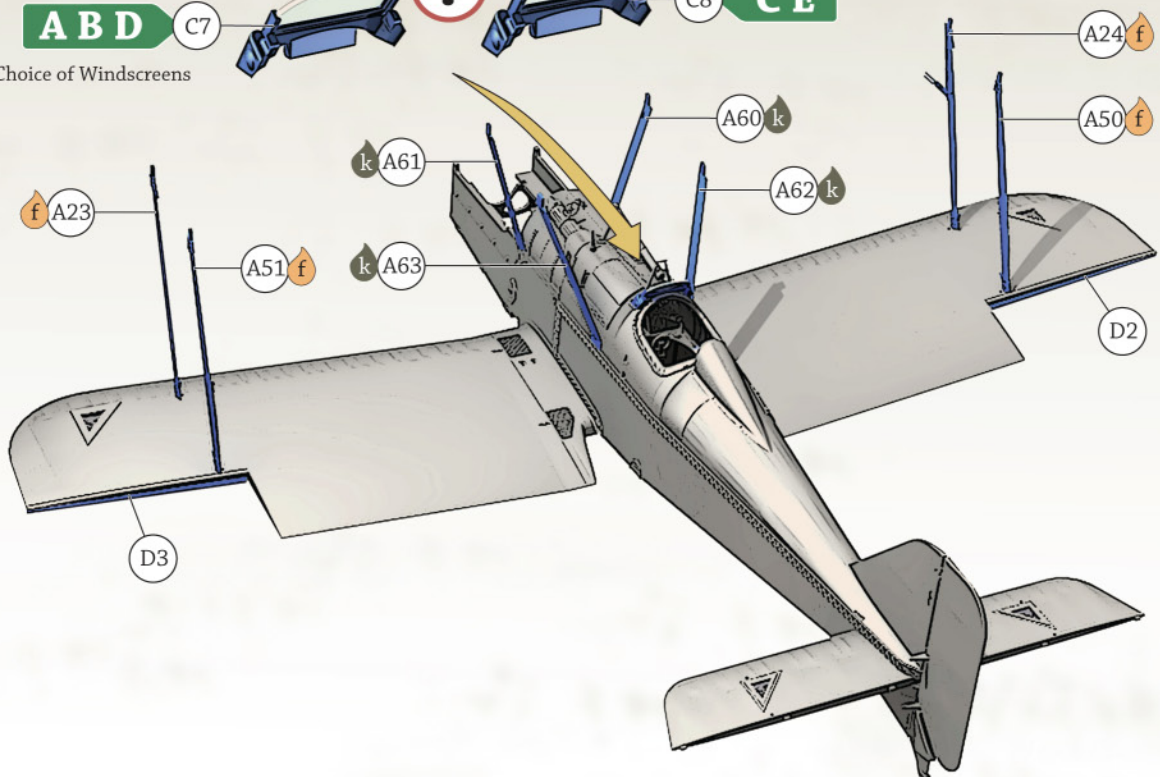

11 UNDERCARRIAGE

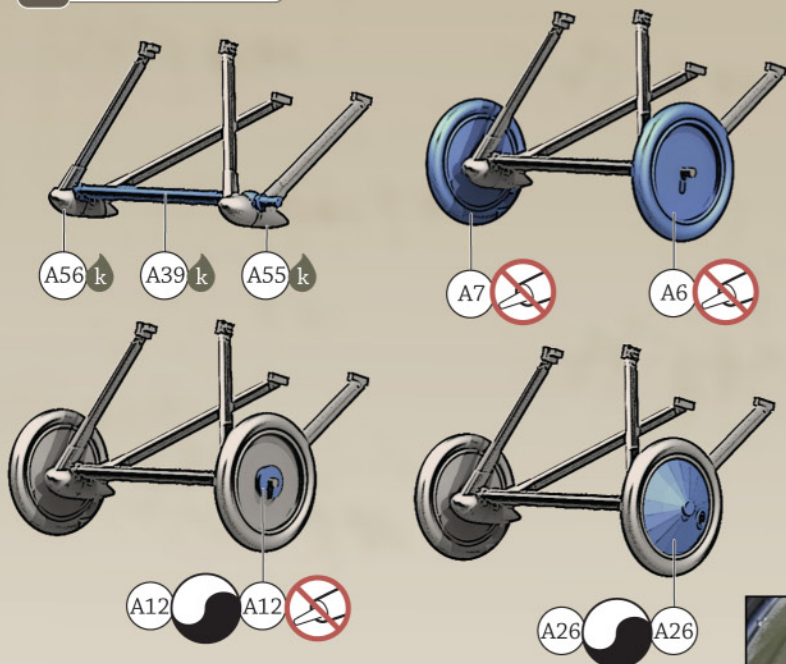

Early steel undercarriage leg from C1057. The bullet shaped bungee cord fairing has been removed, possibly to prevent an excessive build up of mud restricting movement.



Detail from WA19 showing late style wooden undercarriage legs with bungee cord bullet fairing. >

< Detail from B4897 showing an early attempt to strengthen the steel undercarriage, Palmer Cord Aero tyre and bullet shaped bungee cord fairing.



12 UPPER WINGS

Paint inspection panel detail as per step 7

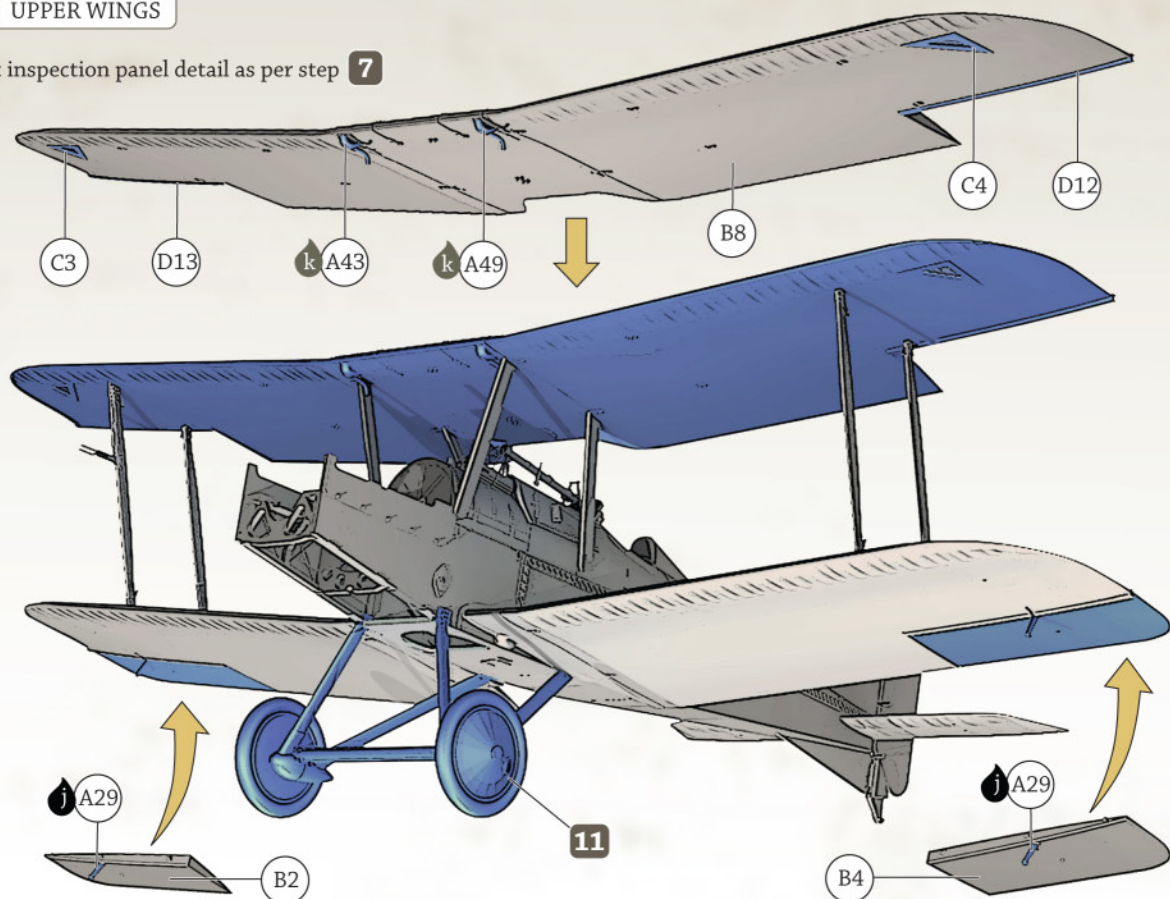

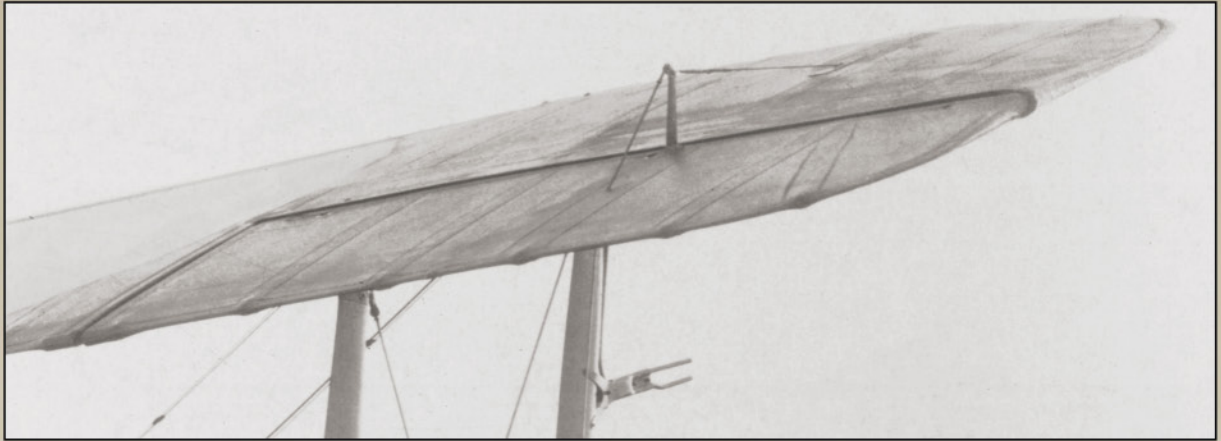

Starboard upper aileron detail from C4897 showing the prominent rib tapes and stitching.



Starboard front cabane strut showing wing fuel tank sump 'bubbles', and fuel line and pitot tube pipes entering the fabric wrapped strut.



Underside view showing rear undercarriage strut attachment brackets, late Viper style baffle plate (firewall) and exit port for spent Vicker gun cartridges.



Front starboard wing strut showing Pitot tube with leads running into the upper wing, strut end bracket and double RAF wire.



Rigging details at top of front left strut.



Undercarriage front strut attachment bracket. Note the two pairs of RAF flat profile rigging wire.



13 LEWIS GUN & FOSTER MOUNT

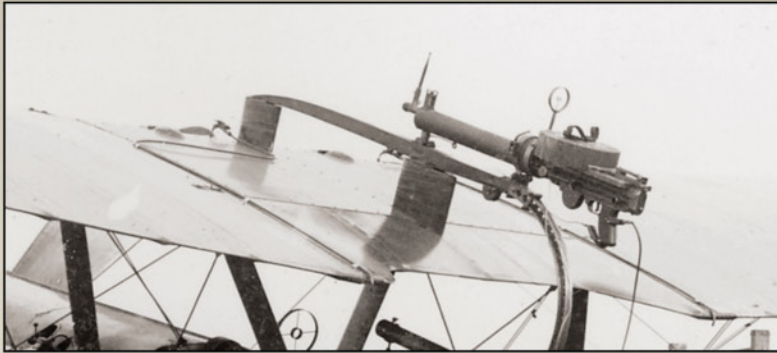
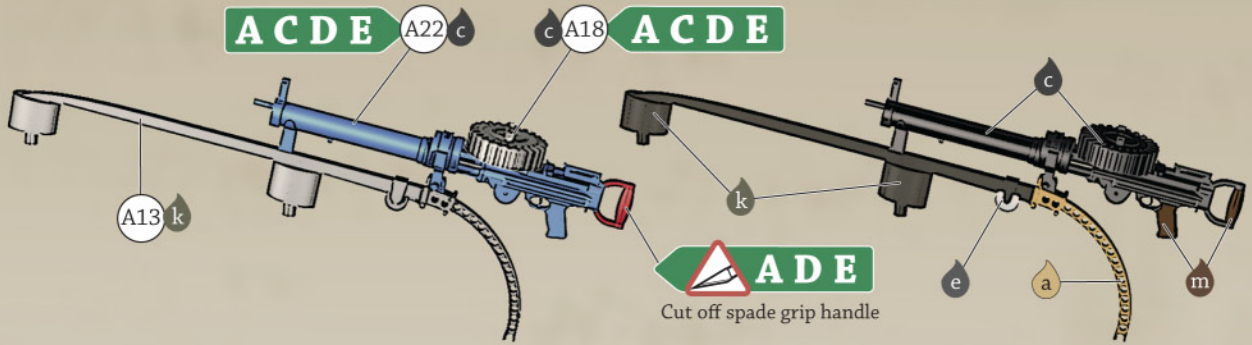

Lewis Mk.II and raised Foster mount on B574. Note the gun sight details, leather handle on the 97 round drum magazine and Bowden cable to remotely pull the trigger from the control column. The higher propeller resulting from a geared engine meant the Foster mount needed to be raised with spacers to allow the Lewis gun to fire over the top.



Foster mount and Lewis gun from TVAL WA19. While WA19 is direct drive powered, it retains the raised Foster mount of a geared engine SE.5a. Many direct drive SE.5a continued to be equipped with raised Foster mounts, even though they no longer required the spacers.

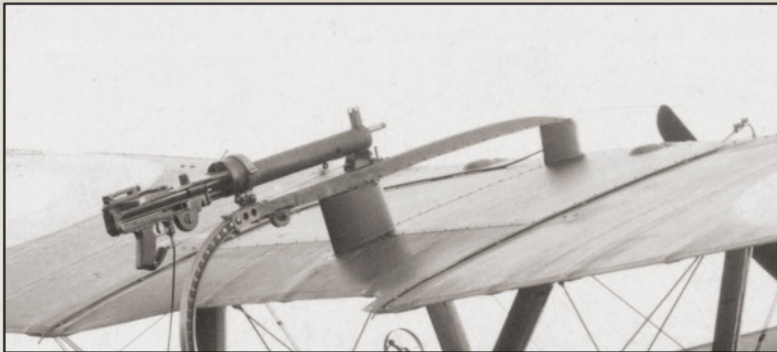

Raised Foster mount and Lewis Mk.II from B4897. Note the different Bowden cable attachment and that the Lewis gun magazine has been removed. Eventually most geared engine aircraft were updated with direct drive power plants and in turn most of these eventually had the now redundant spacers removed from their Foster mounts.



Changing a Lewis Gun magazine in flight can seriously hinder your ability to dogfight.



Note the holes in the end of the lightened casing to aid the flow of air to cool the barrel.



Lewis Mk.II (RFC pattern with lightened barrel casing). Note the dark wooden hand grips and the leather strap on the 97 round drum magazine.

14 AILERONS AND ELEVATORS

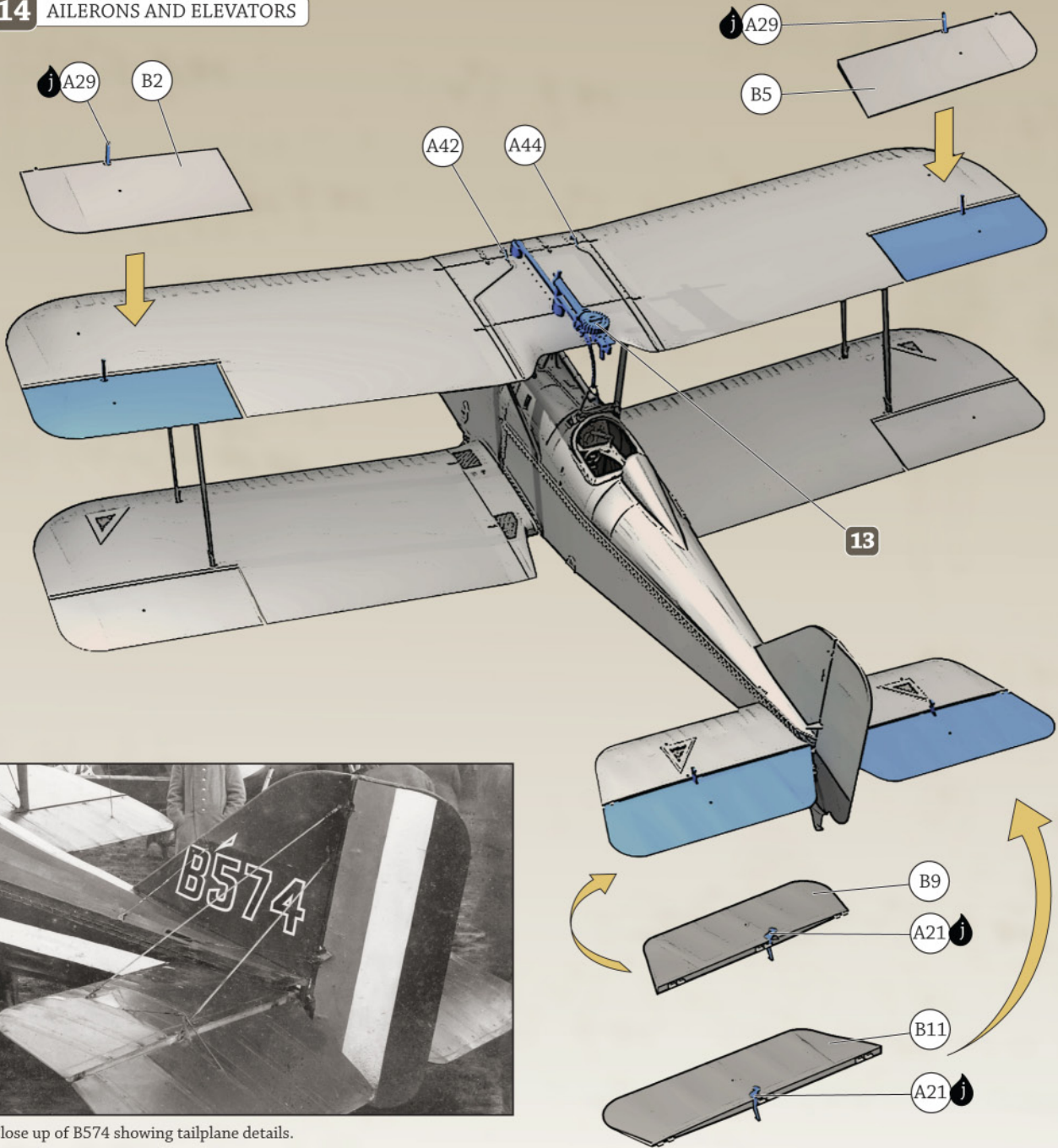

Close up of B574 showing tailplane details.



Aileron view from WA19.



Tailplane and elevator from WA19, note the clear pulley inspection panel and prominent rib tape stitching.

15 HISPANO-SUIZA GEARED ENGINE



Painting Guide

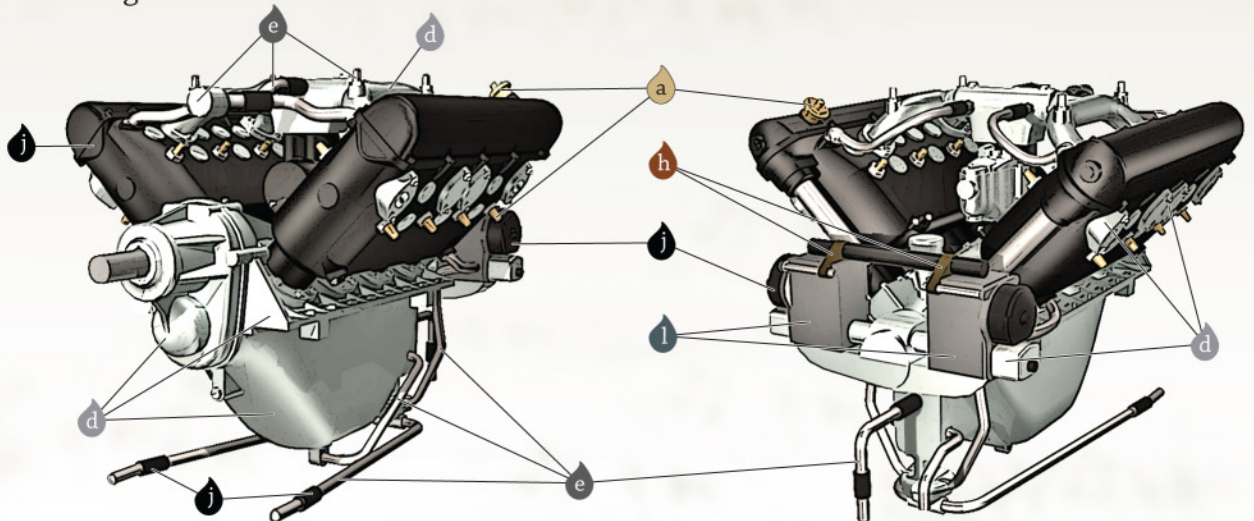

16 RADIATORS AND EXHAUST

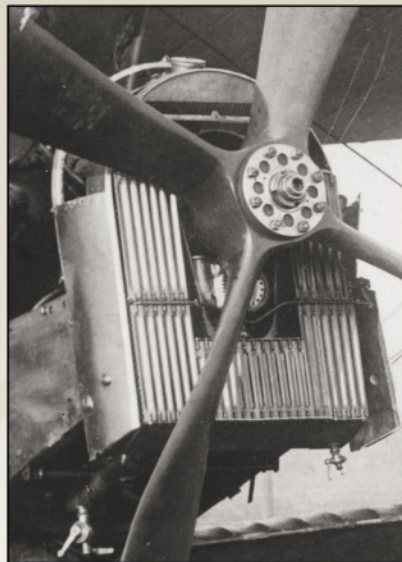
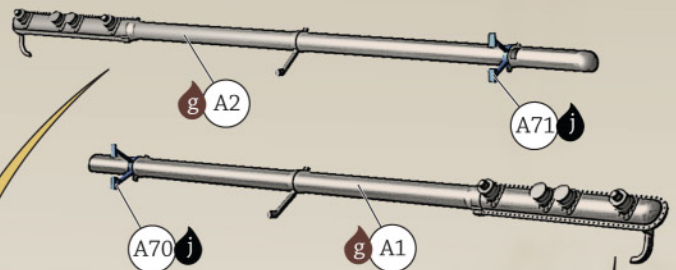
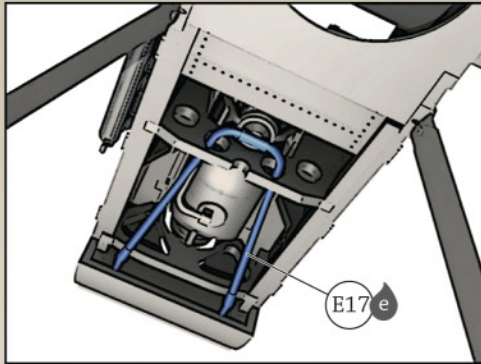
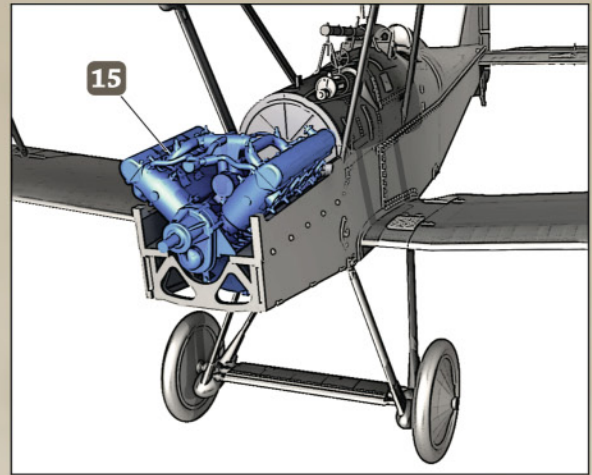
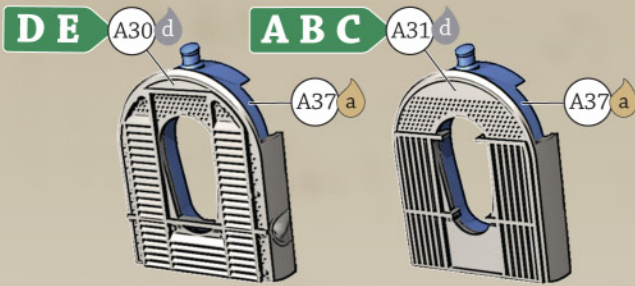

The gears of the Contantinesco synchronizer (interrupter) gear for the Vickers gun are visible under the propeller in this close up of C1057.

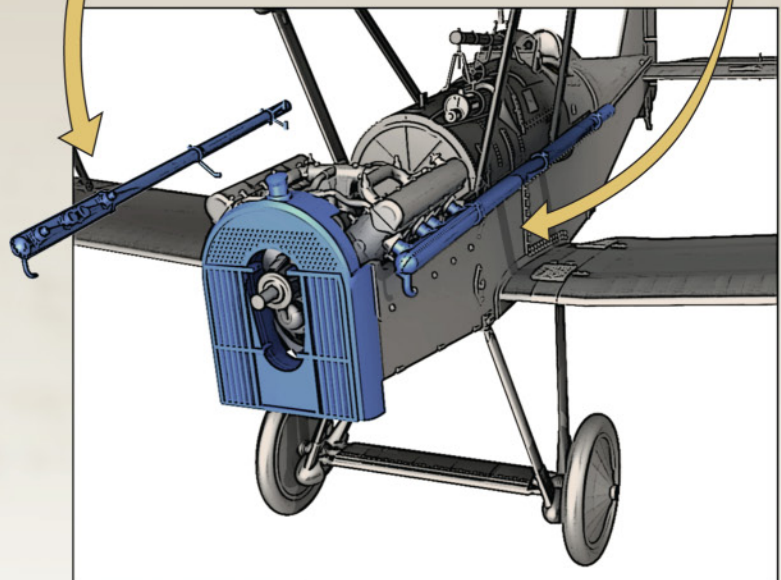

Note the fuel tank details, various brackets and fabric wrapped cabane struts visible in this shot of WA19. This aircraft is powered by a genuine Hispano-Suiza engine, though it is one of the direct drive types and doesn't have the fairing details of our geared engine model.

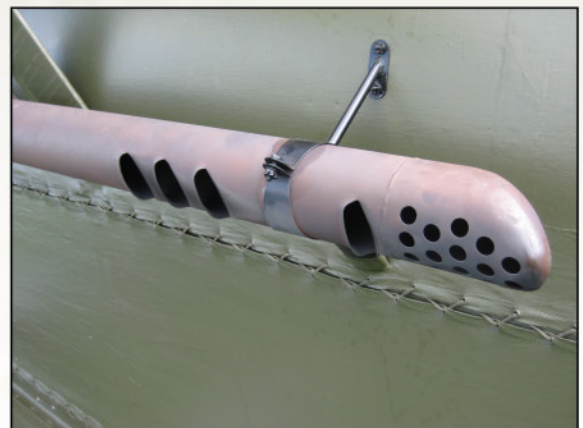

Exhaust detail from WA19.

17 PROPELLERS



Close up view of propeller and nose details.

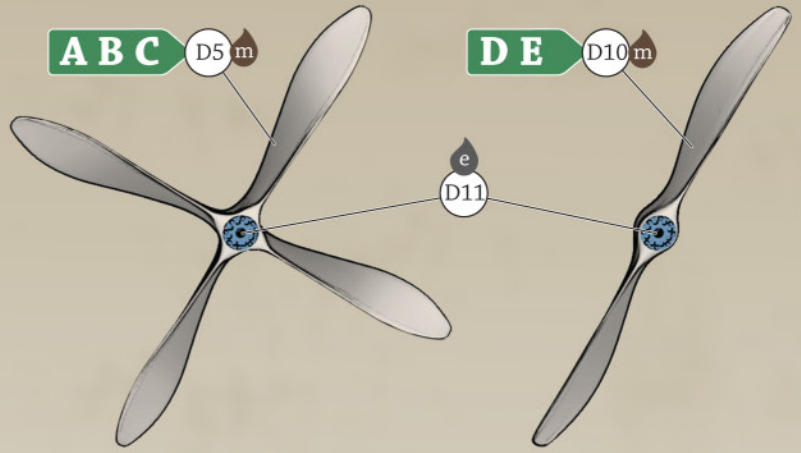

18 FINAL ASSEMBLY



Nose detail from B4897 showing round cutouts in the cowling for the engine priming cups and rigging details.

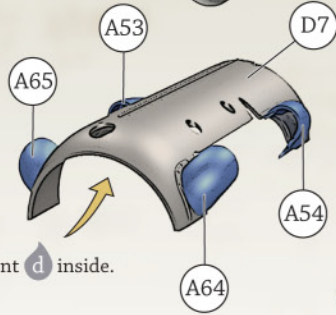

Paint **d** inside.

We recommend leaving off the cowling to better display the engine detail.

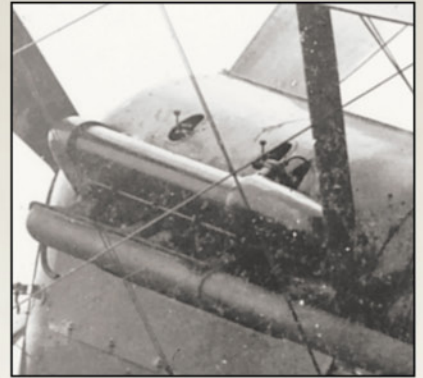

This view of B574 shows the aerodynamic fairings at the front and rear of the protruding cylinder banks, a feature typical of geared engines SE.5as. Note the bleeder pipe at the front of the exhaust.

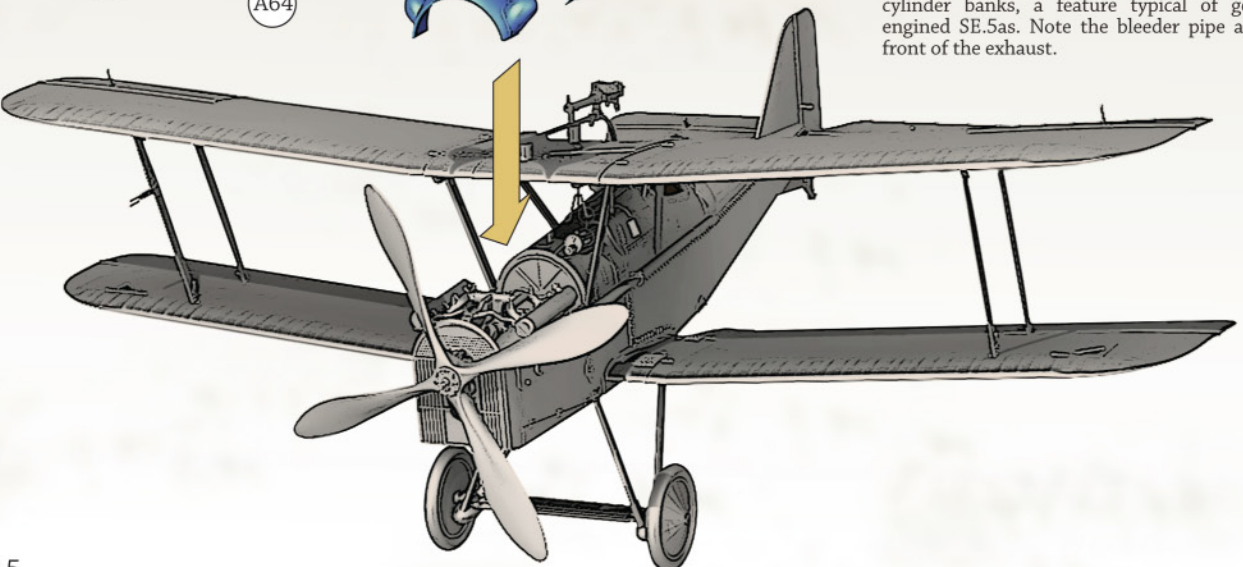

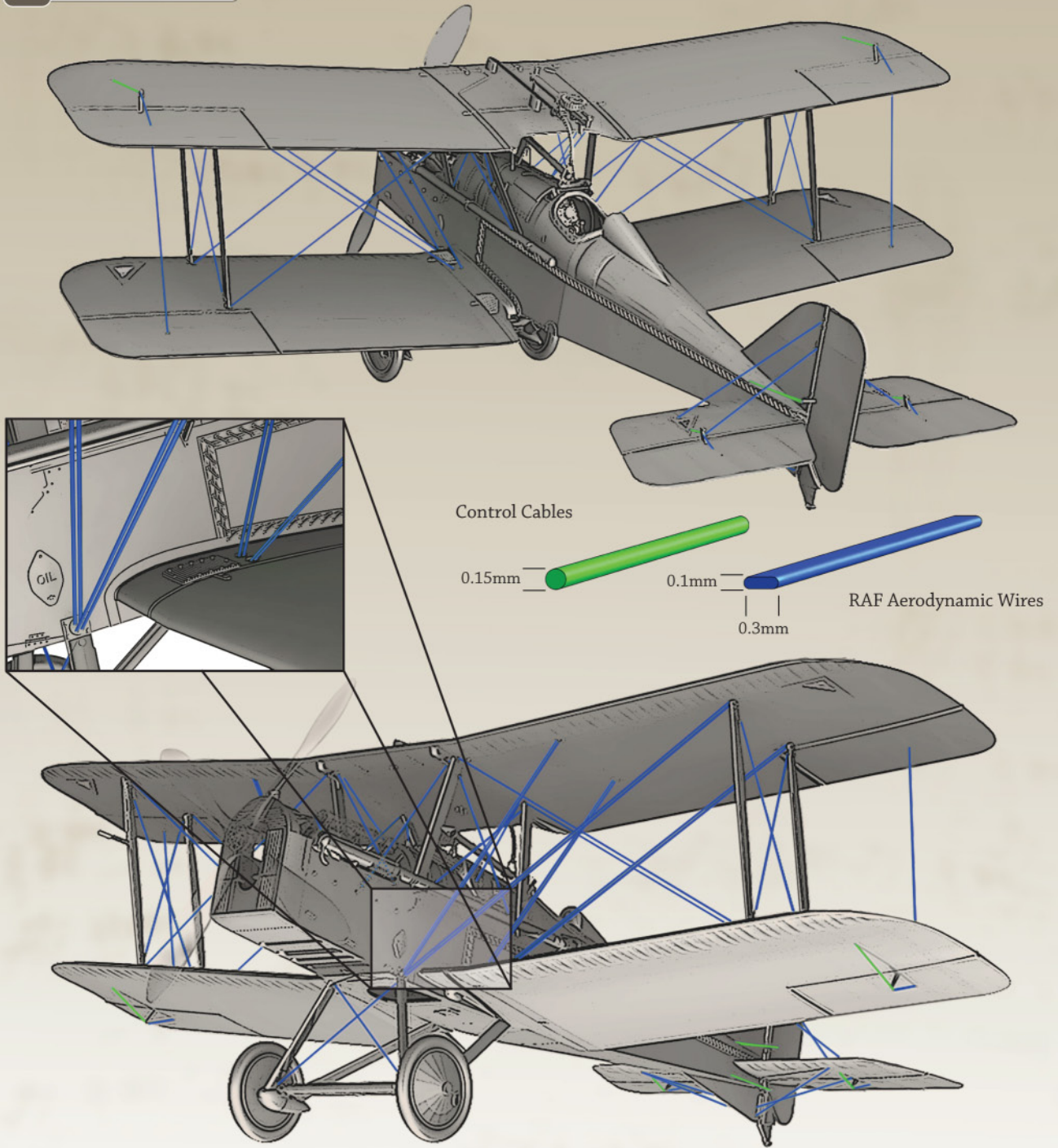

SE.5A-1 WA19 Hispano Suiza direct drive, built by The Vintage Aviator Ltd and completed in March 2007.

A B574 'F', Vickers Built, 84 Sqn, 2nd Lt T.V. Lord, October 1917

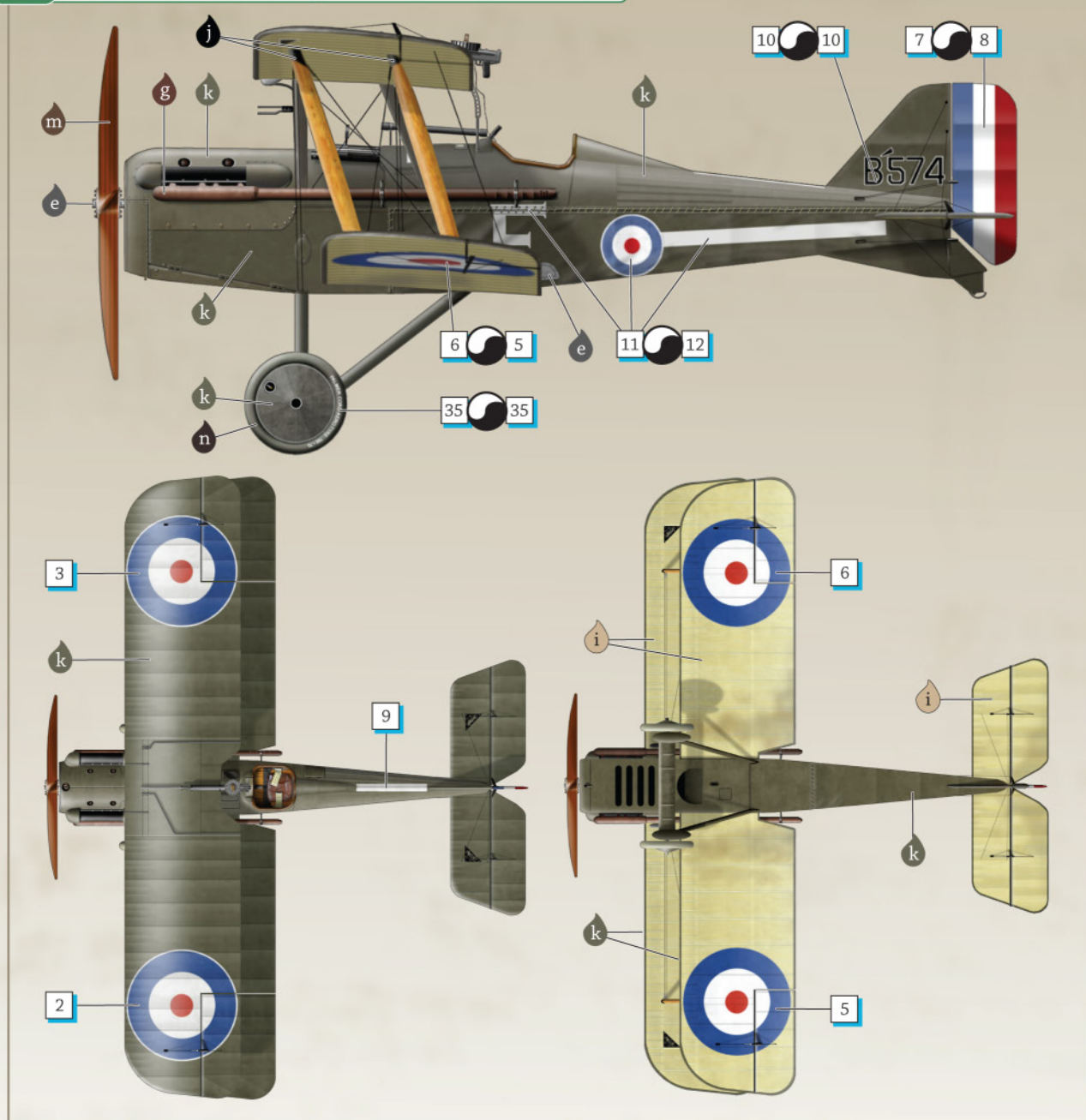

B B603 'Niada Gana', Vickers Built, UK training unit, 1917-18

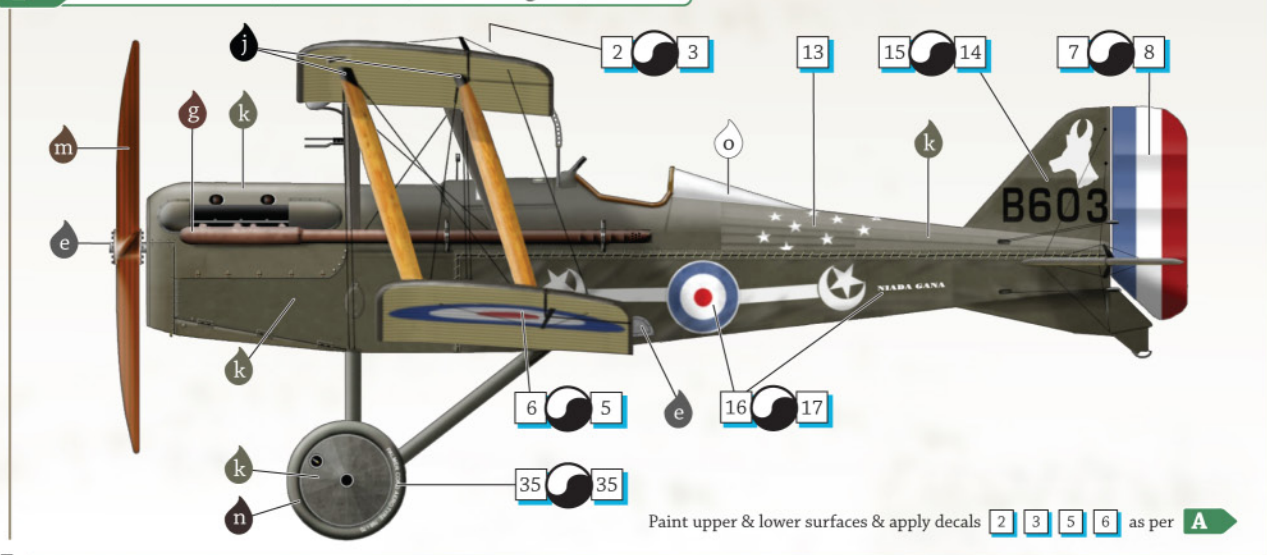

Paint upper & lower surfaces & apply decals 2 3 5 6 as per **A**

C C1057 'C', RAF built, 24 Sqn, 2nd Lt A.P.C. Wigan, March 1918

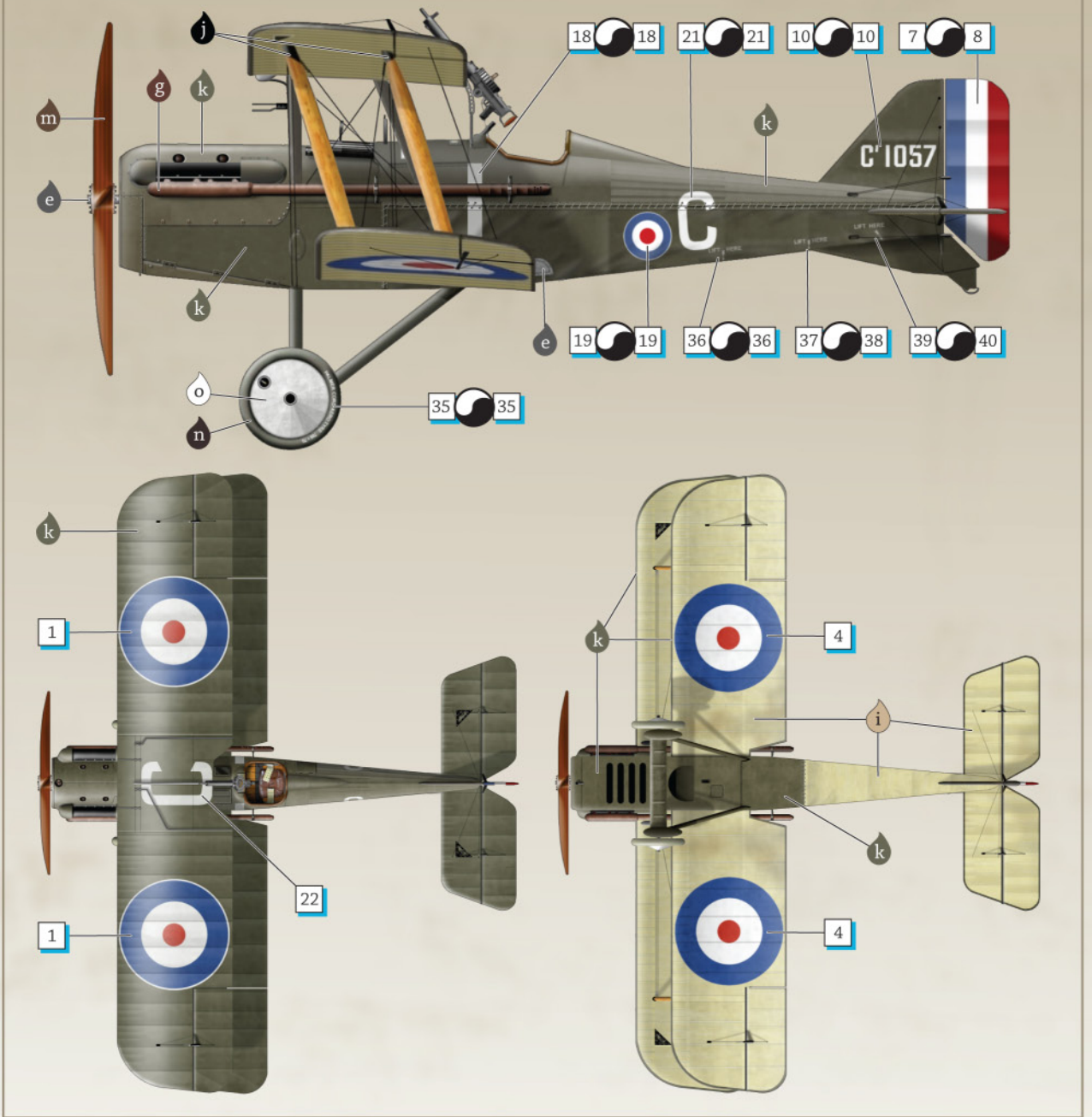

D D351 '4', Vickers built, 6th Training Sqn AFC, October 1918

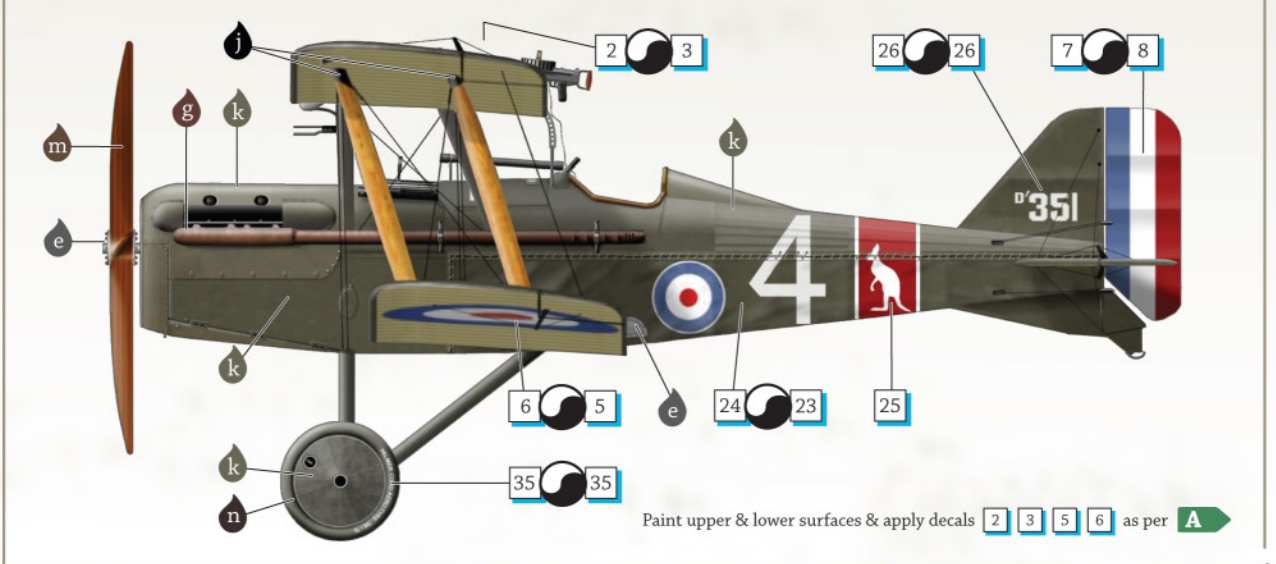

E D3540 'K', Vickers Built, 40 Sqn, Capt G.H.Lewis, April-May 1918

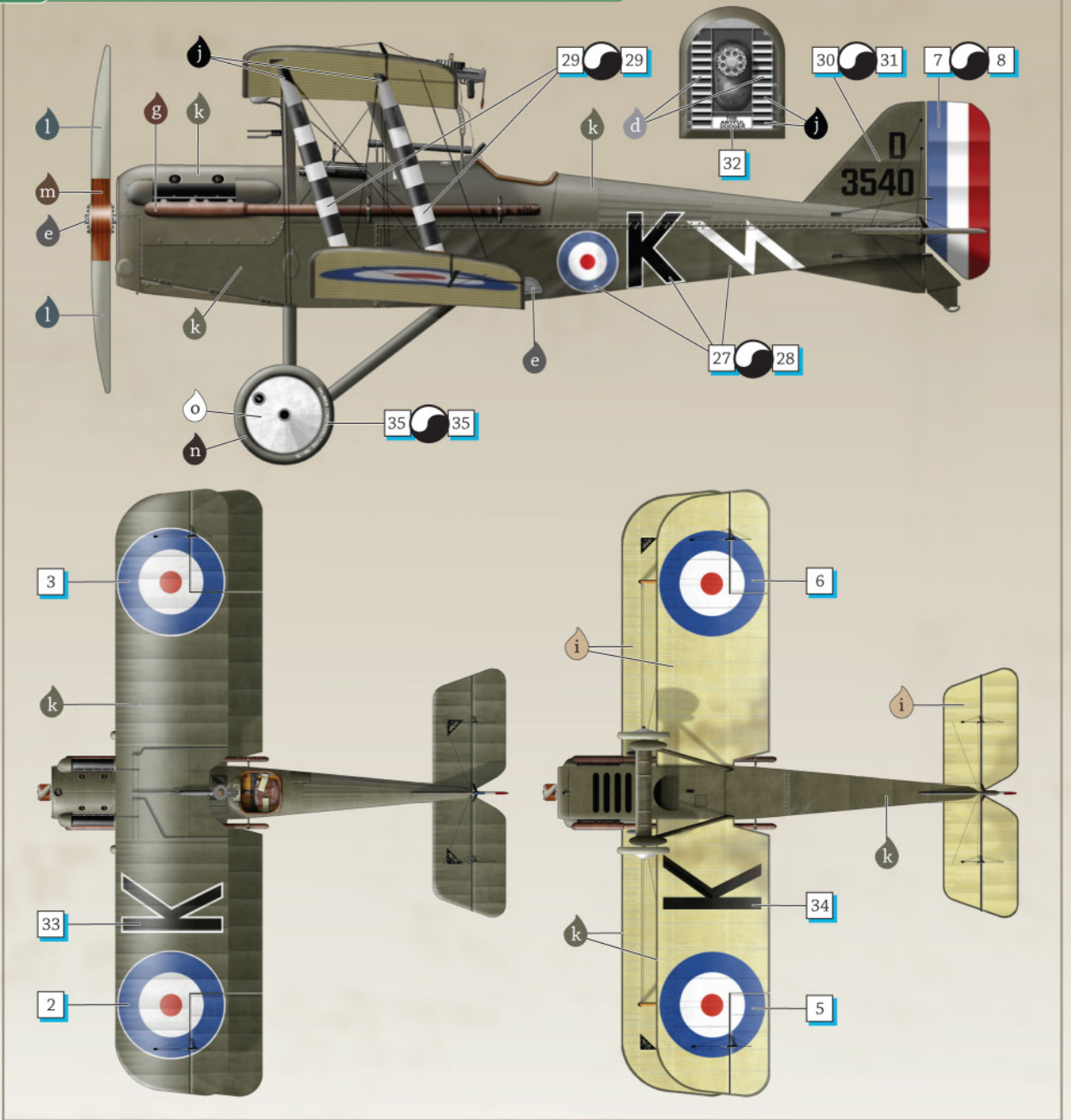

SE.5A-1 WA19 built by The Vintage Aviator Ltd.



SE.5a B4897 Hispano Suiza geared, built by the Royal Aircraft Factory and completed in November 1917. Lt AW Morey of 60 Sqn was flying this aircraft when it collided with a Jasta 7 Albatros of Ltn d R Moebius at 12,000ft on 24 January 1918. Both pilots were killed.



SE.5a C1057 Hispano Suiza geared, built by the Royal Aircraft Factory and completed in December 1917. 2nd Lt A.P.C.Wigan of 24 Sqn was made POW after being shot down by Hpt Adolf Ritter von Tutschek (shown here), CO of JG2 on 6 March 1918.



SE.5a B'574 Hispano Suiza geared, built by Vickers Ltd and completed in Sept 1917. 2nd Lt T.V.Lord of 84 Sqn made POW after a fight with Jasta 15 on 15 October 1917.



SE.5a B'574 October 1917. An OAW built Albatros D.III and a Pfalz D.III can be seen in the background.



3-D Modelling by Jose Samson

Jose Samson is a 3D modeler for film and television. He developed an interest in aircraft at an early age, going to air shows as a military brat. His first model kit was an F-14 Tomcat from the famed VF-84 Jolly Rogers Squadron.

After a foray into civil engineering, just long enough to realize it was not the field for him, he decided that 3D animating for film would be a way to combine all his interests into a career.

Building 3D representations of real world and science fiction became his passion and his career, leading him to work for Weta Digital in New Zealand. Working at Weta on this project has been a great experience for Jose who can now say he modeled a 3D representation of a famous World War 1 aircraft. He hopes that many people will appreciate the effort it took to get this model kit into your hands. This model is really for you...



Box Art by Steve Anderson

Steve Anderson is an avid historian of military aviation, with a special interest in the many beautiful biplanes and triplanes of World War I. The aircraft and battles of famous World War I aces such as Baron Manfred von Richthofen (better known as the "Red Baron"), James McCudden, Raoul Lufbery, Ernst Udet, Werner Voss, and other pioneers of dogfighting are among Steve's favorite subjects.

An Artist Fellow of the American Society of Aviation Artists, Steve creates works that reflect scrupulous attention to historically accurate detail, from the colorful markings on the fuselages to the time of day of an actual battle.

Visit Steve's website at: www.anderson-art.com.



Profile Art by Ronny Bar

Ronny Bar developed a keen interest in airplanes from an early age, living close at the El Palomar Air Force Base in Buenos Aires. He first flew in the back seat of a T-34 Mentor trainer at the age of ten, and was soon drawing airplanes and

building models: Spitfires and Messerschmitt first... Camels and Fokkers later.

He became a successful bass player with a career lasting over 35 years in several Rock bands, recording ten albums (one of them being a National hit selling more than 100,000 copies) and performing countless concerts, TV shows and tours all over Argentina.

Now retired from the R'n'R scene, his interest returned to his early passion: Aviation Artwork. Visiting the WW1 aircraft collection at Hendon focused his already growing interest for that historic period. His artwork is regularly appearing in journals and publications like Windsock Worldwide, Windsock Datafiles, Cross & Cockade and Over the Front.

You can contact Ronny at: ronibares@yahoo.com.ar
See artwork at: www.wwi-models.org/Images/Bar/Art/index.html



Project Co-ordinator, Richard Alexander

A native of Wellington New Zealand, Richard Alexander has a long term interest in military history, race cars & local drivers from motor sports golden era of the '60's. Other interests include mountain biking, scotch and cigars.

An accomplished modeller Richard's models have twice been awarded Best Overall in Show at IPMS(NZ) National Conventions and earned him the inaugural TamiyaCon(NZ) Master Modeller award (along with the associated trip to Japan) in 2001. Many of his works are in private collections around the world, though he no longer accepts commissions.

Richard has been in the model and hobby industry since 1991 and brings with him a keen eye for detail and a passion for ensuring our models are enjoyable to build. So if there is anything you don't like about this model, you can blame him.

If you do have comments, requests or suggestions, Richard is contactable at richard@wingnutwings.com



32003	1/32 SE.5a 'Hisso'	Qty
0132003A	A parts	1
0132003B	B parts	1
0132003C	C parts	1
0132003D	D parts	1
0132003P	Photo-etched metal parts	1
132E0002	E parts Hispano-Suiza Engine	1
7132003	Instructions	1
9132003	Decals	1



32001 - 1/32 Junkers J.1



32002 - 1/32 LVG C.VI



32004 - 1/32 Bristol F.2b Fighter

Available now from
www.wingnutwings.com

© Wingnut Wings Ltd. PO Box 15-319 Miramar, Wellington 6243 New Zealand.
 All rights reserved. Designed in New Zealand - Manufactured in China.