

1/32 SCALE

ITEM NO.:03204

F/A-18E Super Hornet

F/A-18E 超级大黄蜂战斗机

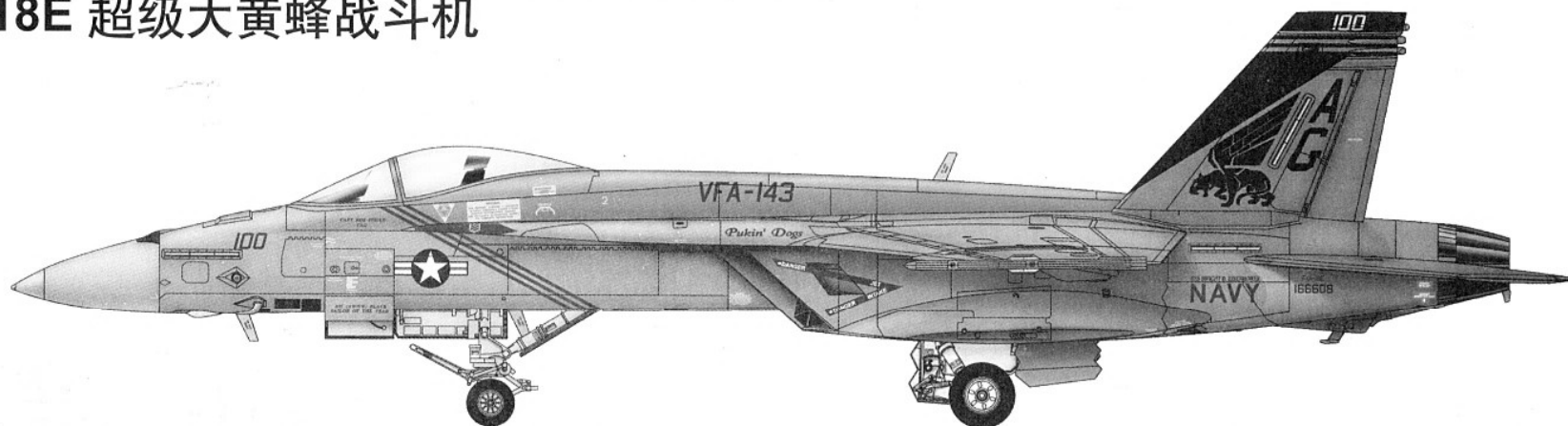

READ BEFORE ASSEMBLY:

- Study and understand these instructions thoroughly before beginning assembly
- When needed, remove photo-etch parts carefully using a modeling knife or photo etch sprue cutter, being careful not to damage or lose small parts.
- Take extra care in handling photo etch parts in order to avoid injury
- Apply instant cement sparingly to photo etch parts where instructed

- Tools recommended(not included in kit):Plastic and instant cements,sprue cutters,long nose pliers,modeling knife, small files, tweezers, pin vise & scissors. Soft cloth and sandpaper will also assist in construction
- Glue and paint are not included in the kit. Use plastic cement and hobby paints only. Color guide for purchasing paint is included in the kit.

装配之前仔细阅读

- 小心用模型锉刀锉平所有零件表面的注射浇口。
- 小心用刀片切下蚀刻片零件，不要遗失小零件。
- 用强力快干胶水粘合蚀刻片零件和金属轴。过量的快干胶水使用可能导致可动零件会粘住，小心涂胶。
- 取蚀刻片时应特别注意安全，防止利边划伤手指。
- 某些零件表面需贴水上贴纸，请选择在装配的同时进行。
- 推荐模型工具(自备)：胶水，水口剪刀，长咀钳，刀片，锉刀，镊子钳，钻，剪刀，瞬间快干胶。
- 软布同砂纸同时也应该是必备工具。
- 请使用塑料胶水和油漆，模型内不含。

水贴纸的使用:

1. 从水贴纸上剪下印花;
2. 将印花放入温水中浸10秒, 然后放在干净布上。
3. 拿着印花纸板将印花移到模型上;
4. 手指蘸水将印花移到适当的位置;
5. 用软布轻压印花直至水干, 气泡消失。

DECAL APPLICATION:

1. Cut decals from sheet as needed
2. Dip the decal in warm water for about 10 seconds and then place on soft clean cloth.
3. Hold the decal backing sheet edge and gently slide the decal onto the model in its proper position.

4. While still wet,decal can be adjusted for better fit on model by dampening it gently with your finger.
5. When placed in the proper position,gently press decal down with a soft cloth until excess water and air bubbles are gone.
6. Allow decal to dry completely before handling model



部品图 Parts

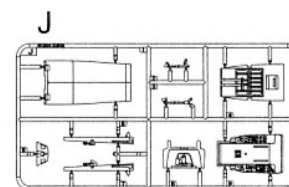
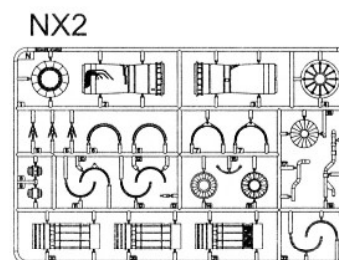
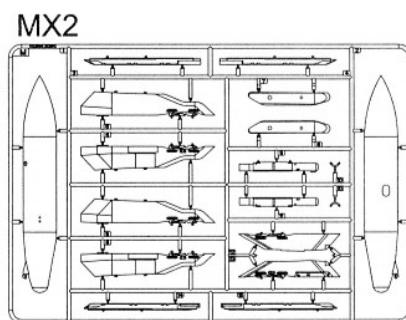
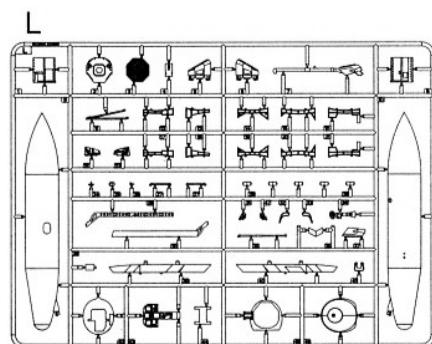
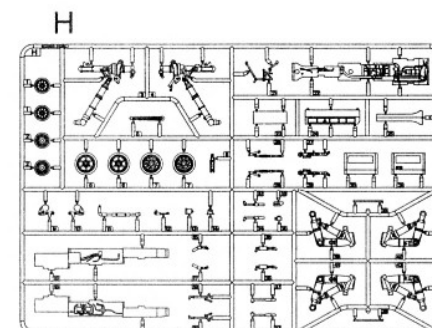
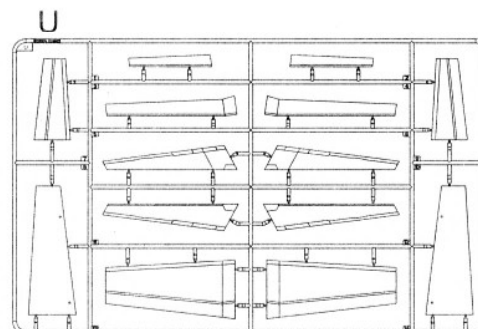
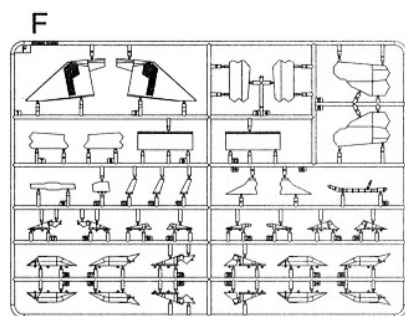
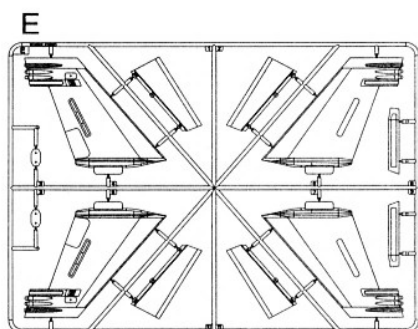
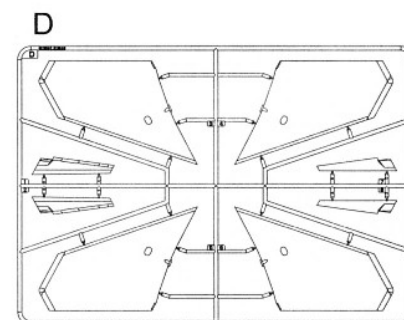
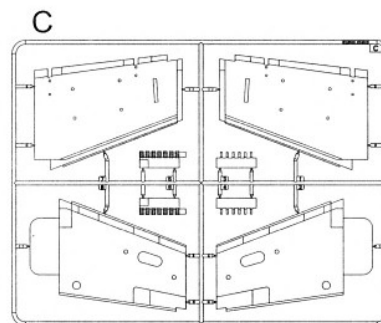
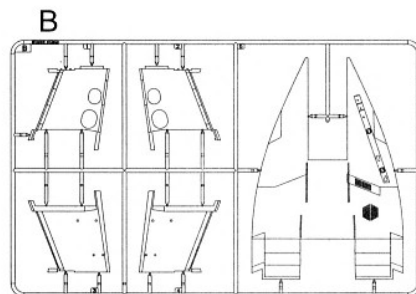
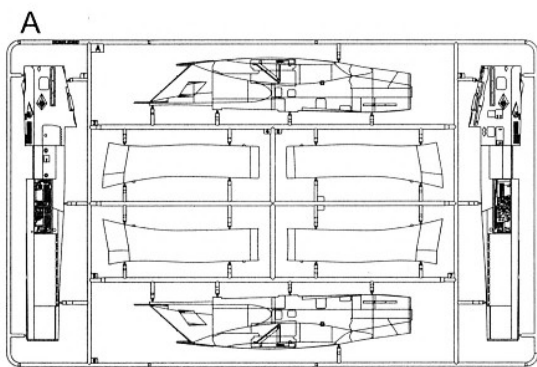

部品图 Parts

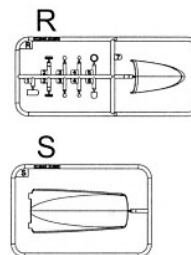
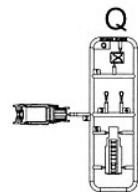
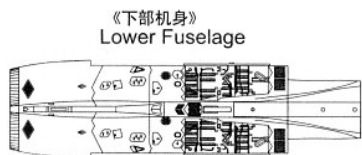
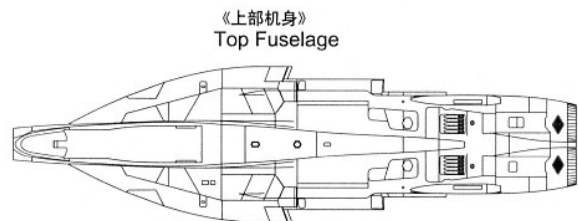

WD X4

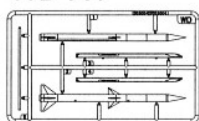

WN1 X2

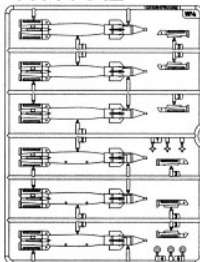

WN2 X2

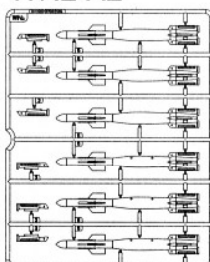

WU1 X2

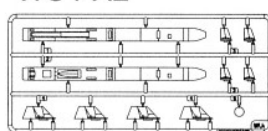

WU3 X2

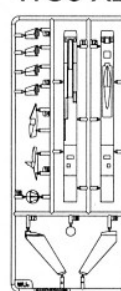

WE X2

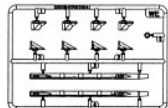

WU2X2

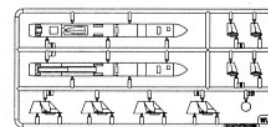

《蚀刻片》
Photo etched part(PE)

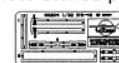

WV X2

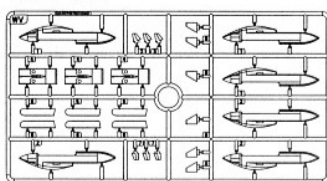

WJ

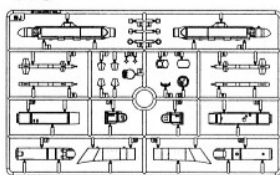

WX2 X2

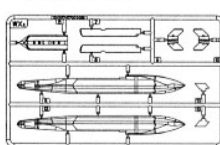

《水贴》
Decal A

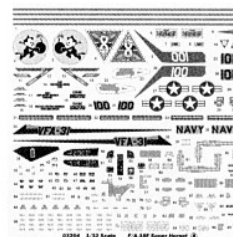

《水贴》
Decal B



《水贴》
Decal C

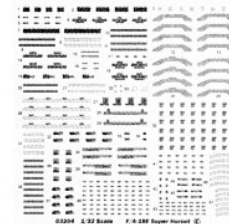

WY

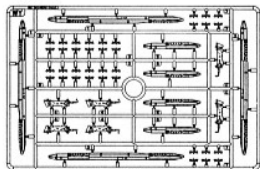

《金属部件》
Metal parts



不用的部件: L44 M7 M9 M11 M14 M15 Q4 WJ1 WJ4
Unused parts WJ12 WJ17 WJ18 WJ19 WJ20 WZ7

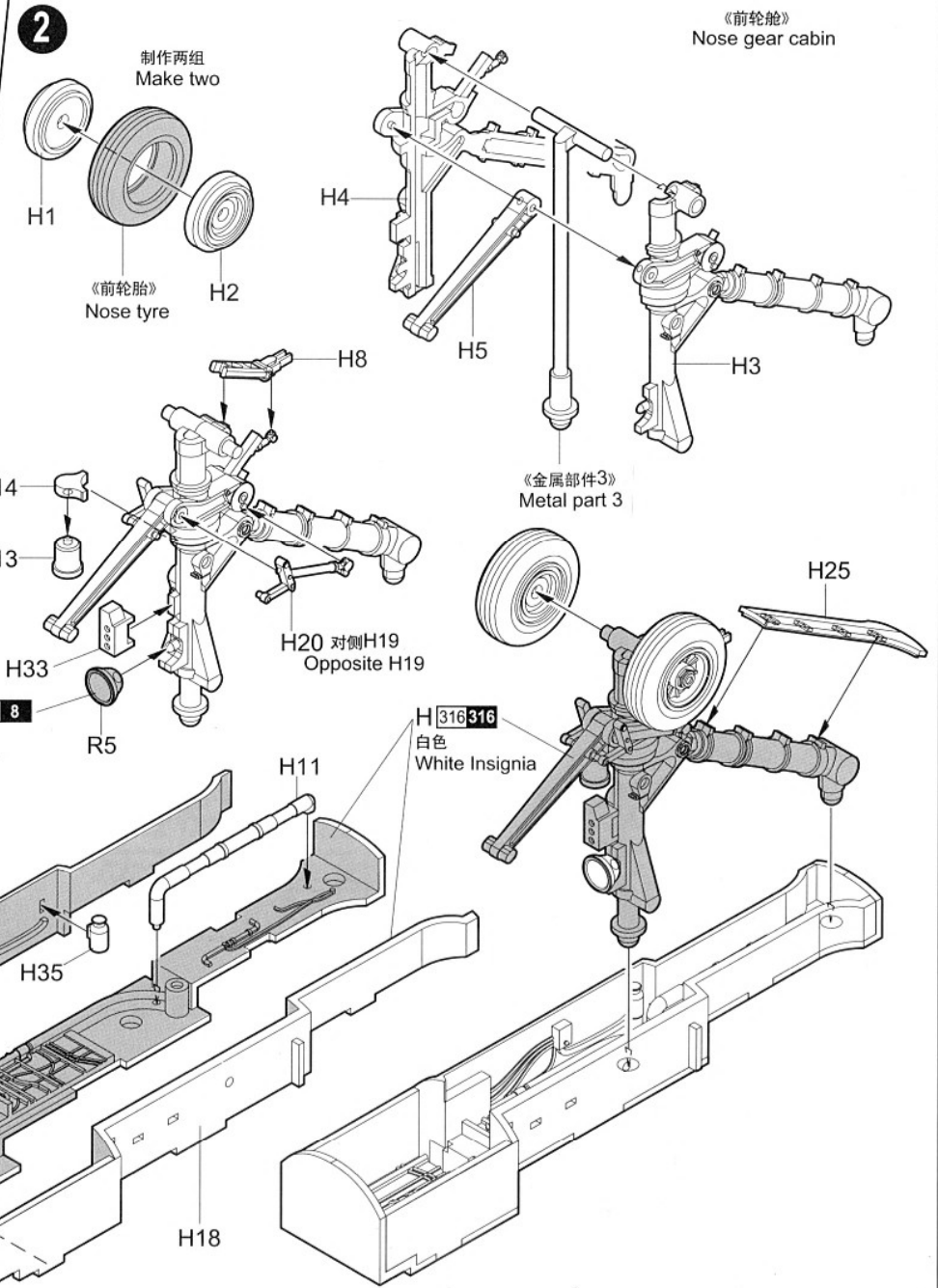
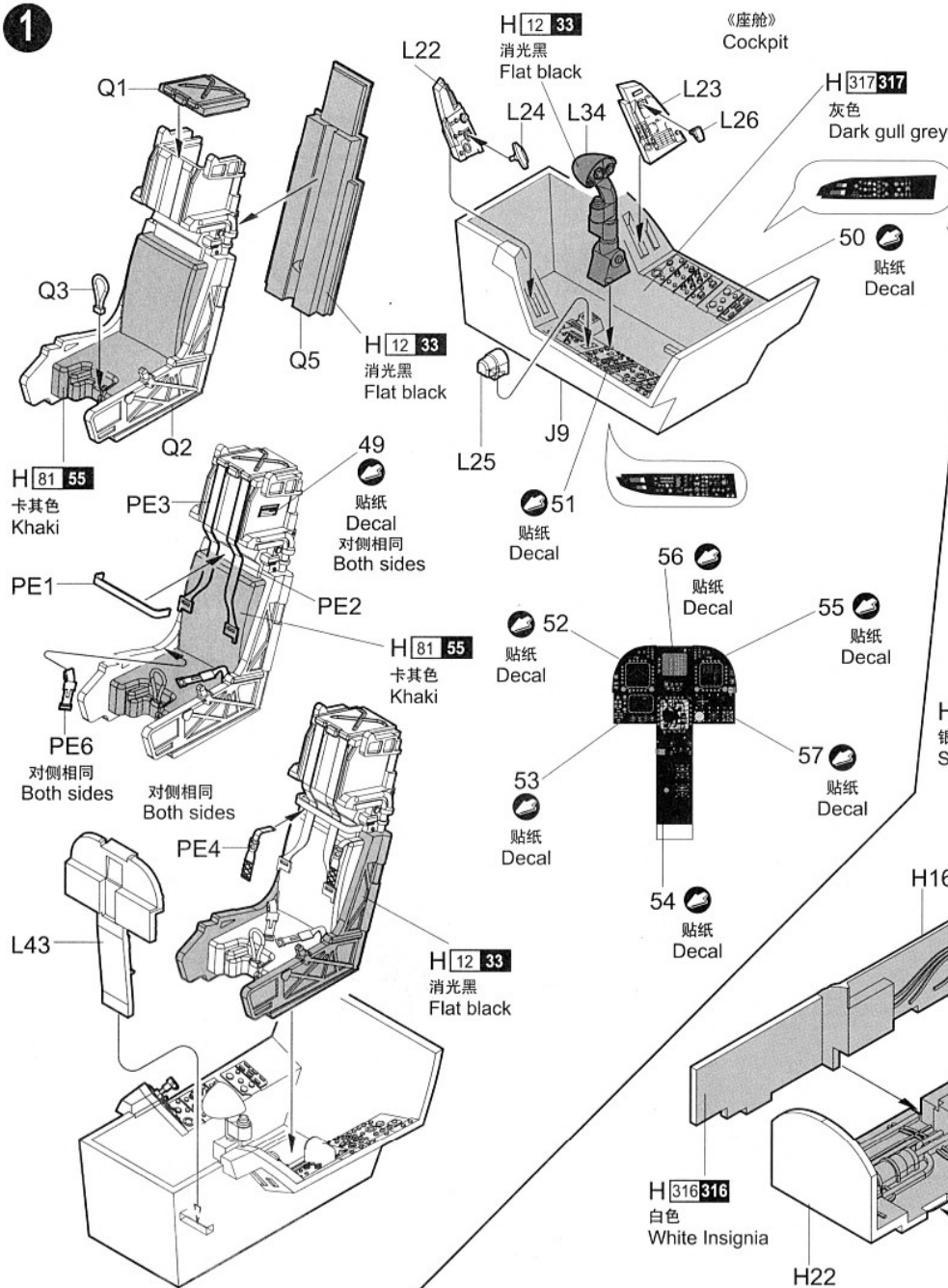

3

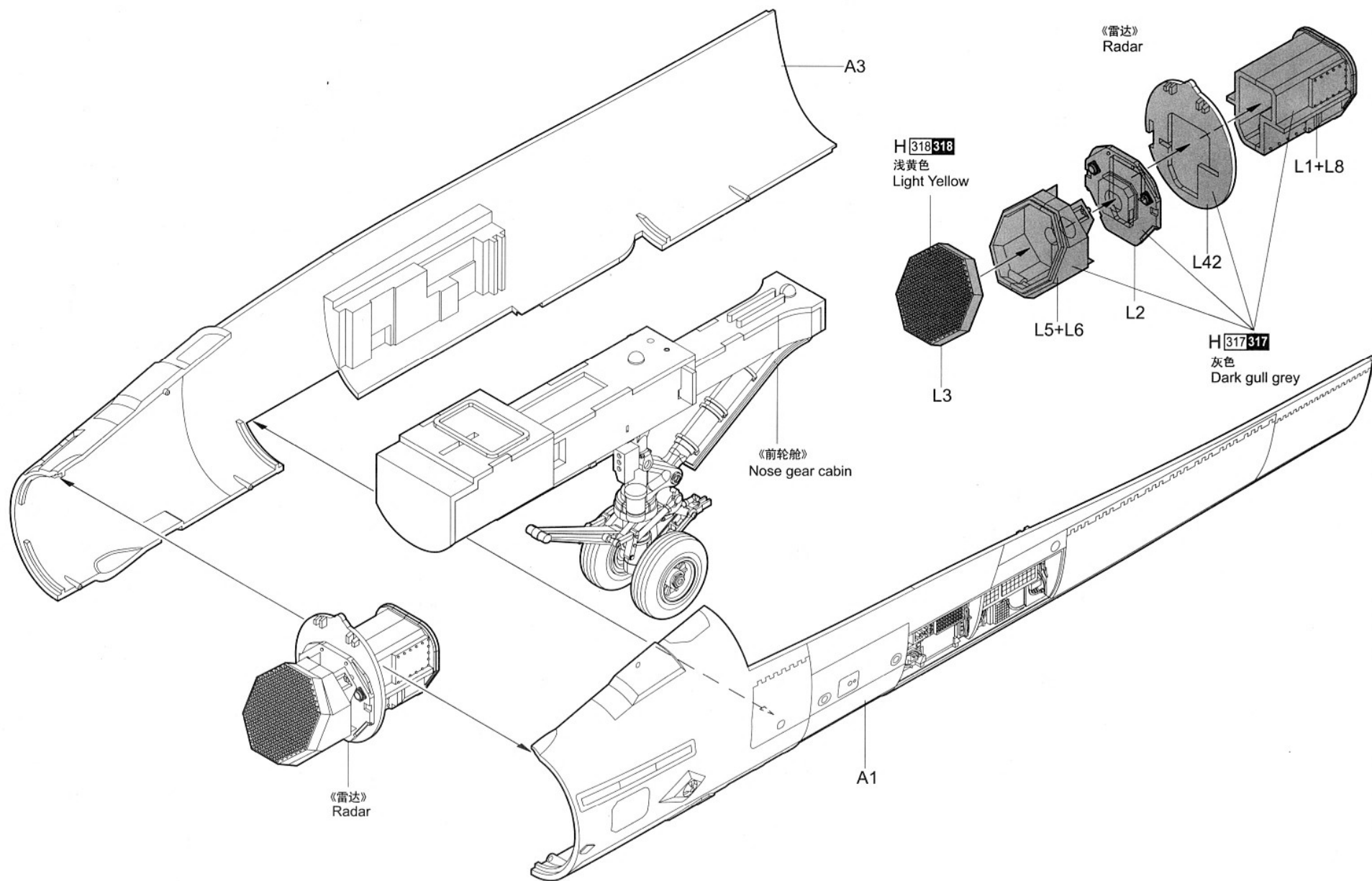

4

《发动机》
Engine

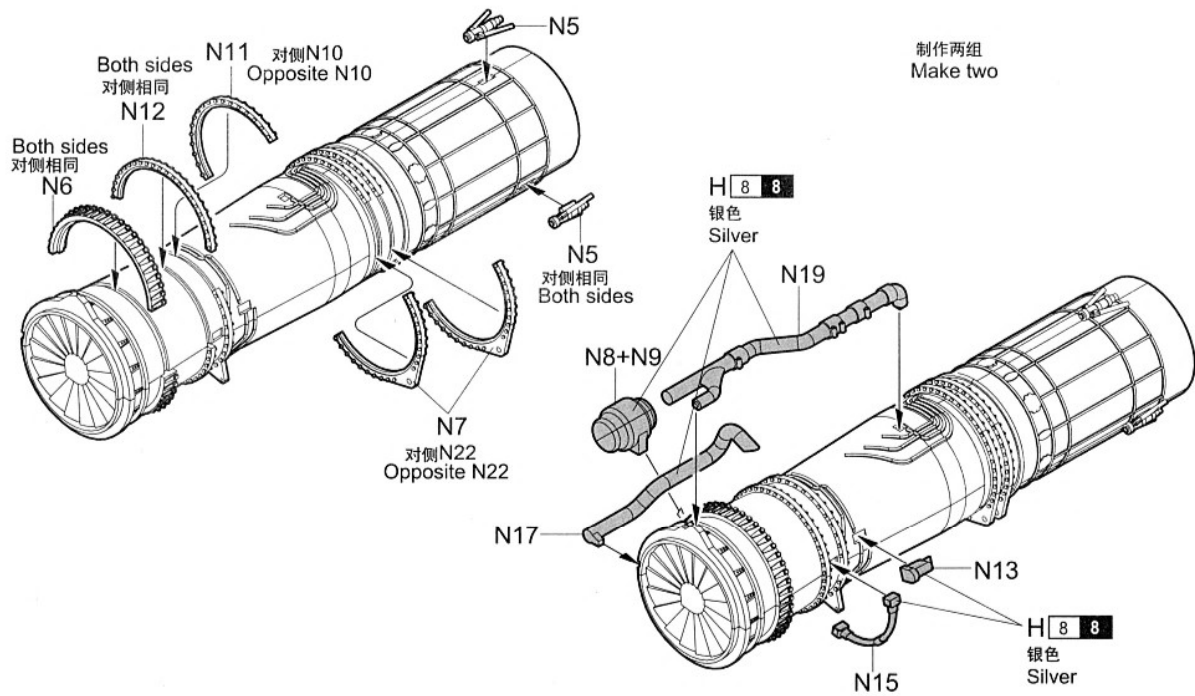
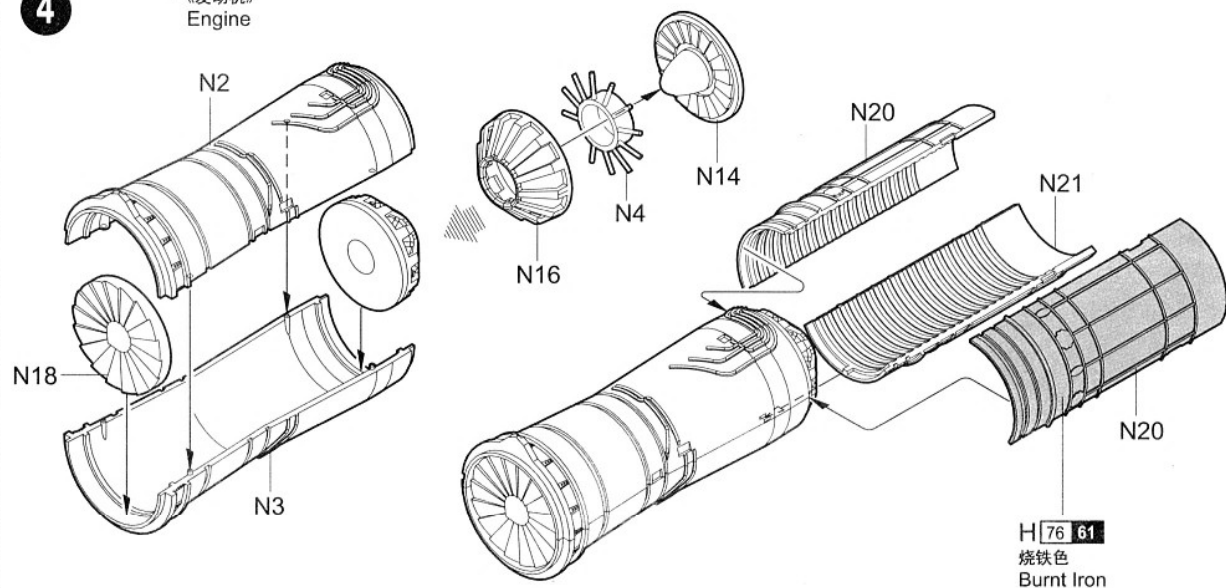

5

《左侧起落架》
Left undercarriage

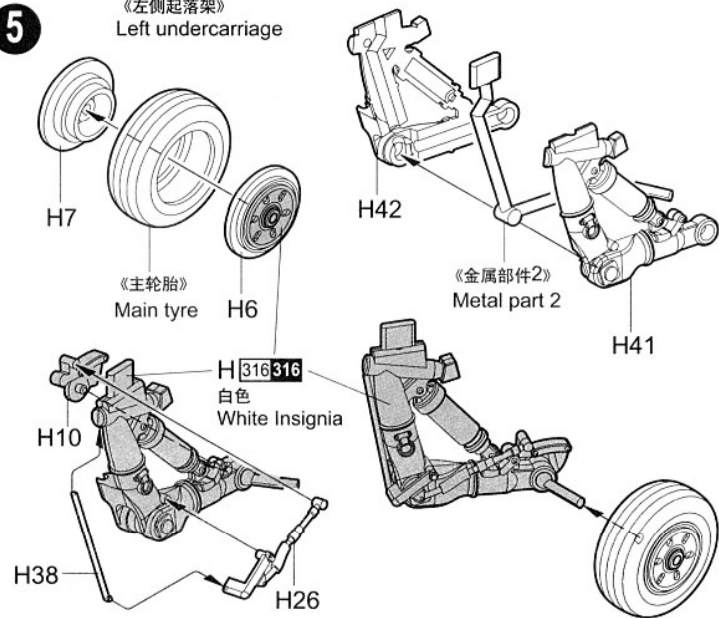

6

《右侧起落架》
Right undercarriage

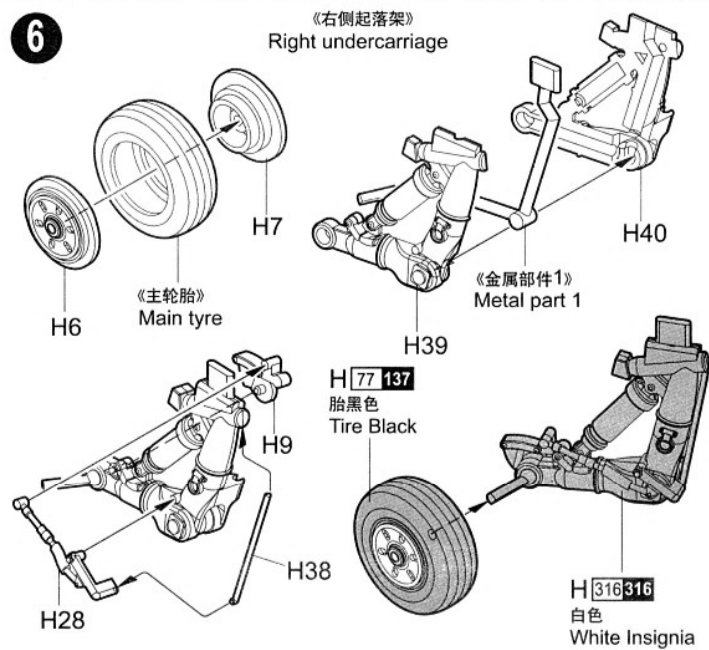

7

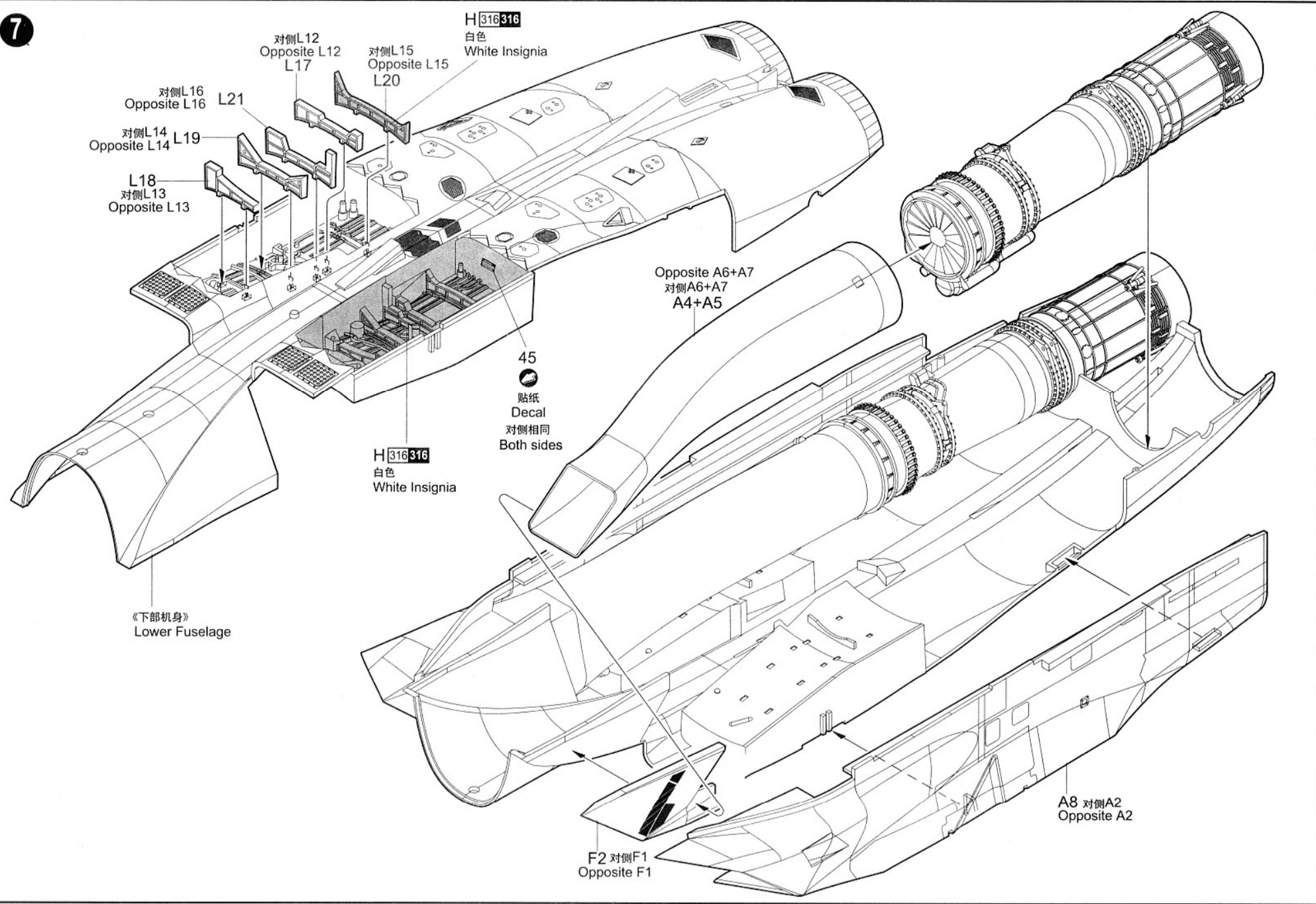

8

《左侧机翼》
Left wing

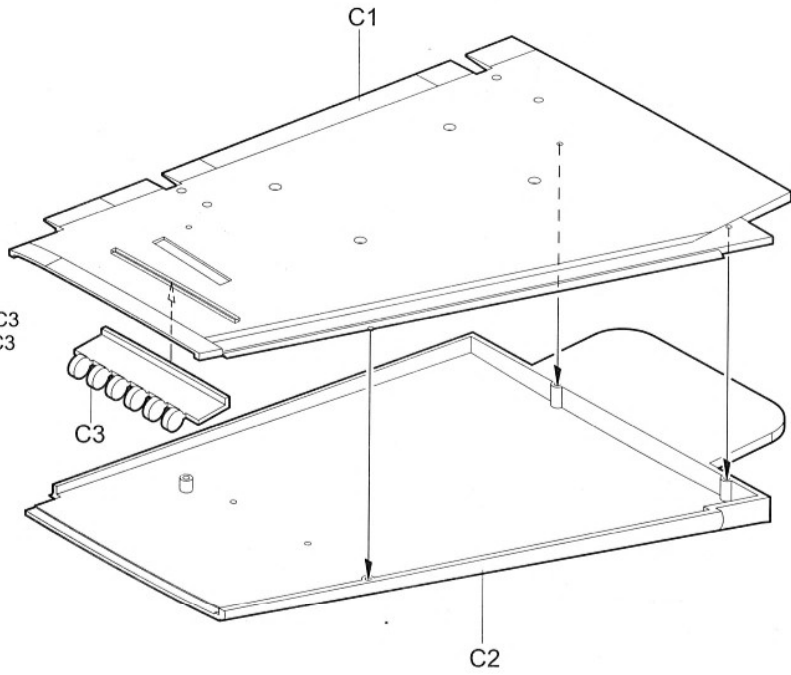
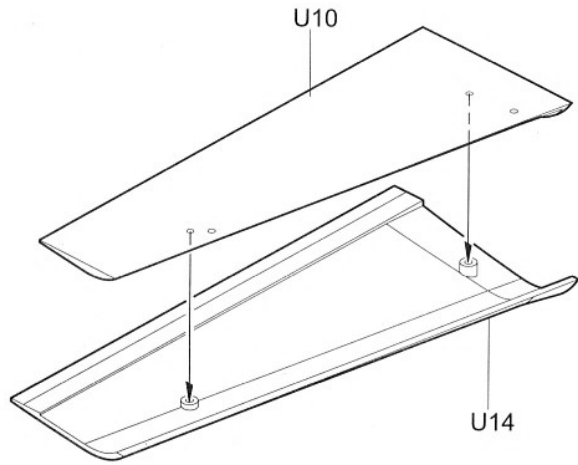

折叠状态时装C3
Attaching C3
when fold

C3

C2

C1

03204

9

《展开状态》
Expanding

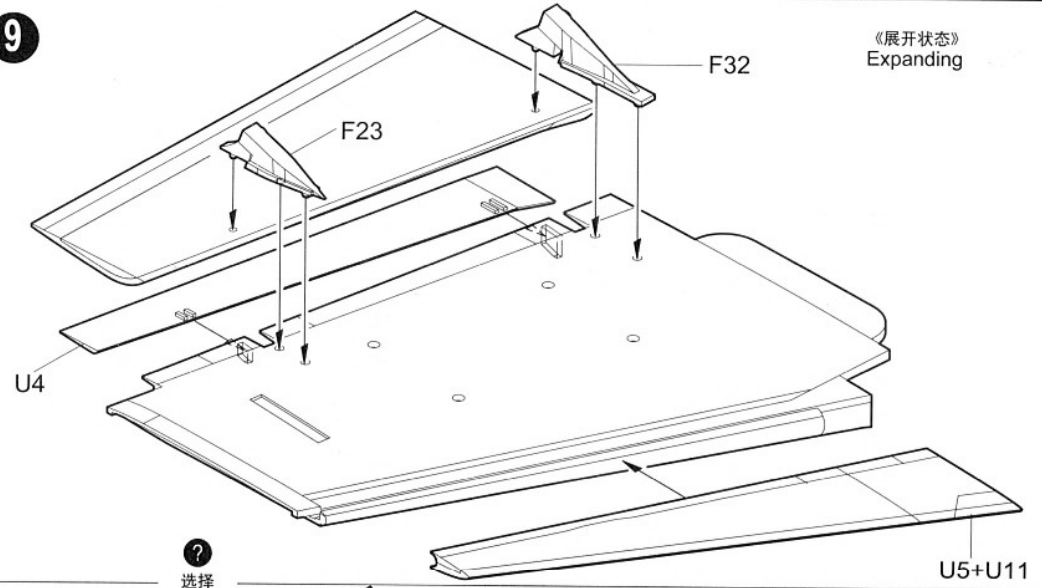

选择
Option

U5+U11

《折叠状态》
Folding

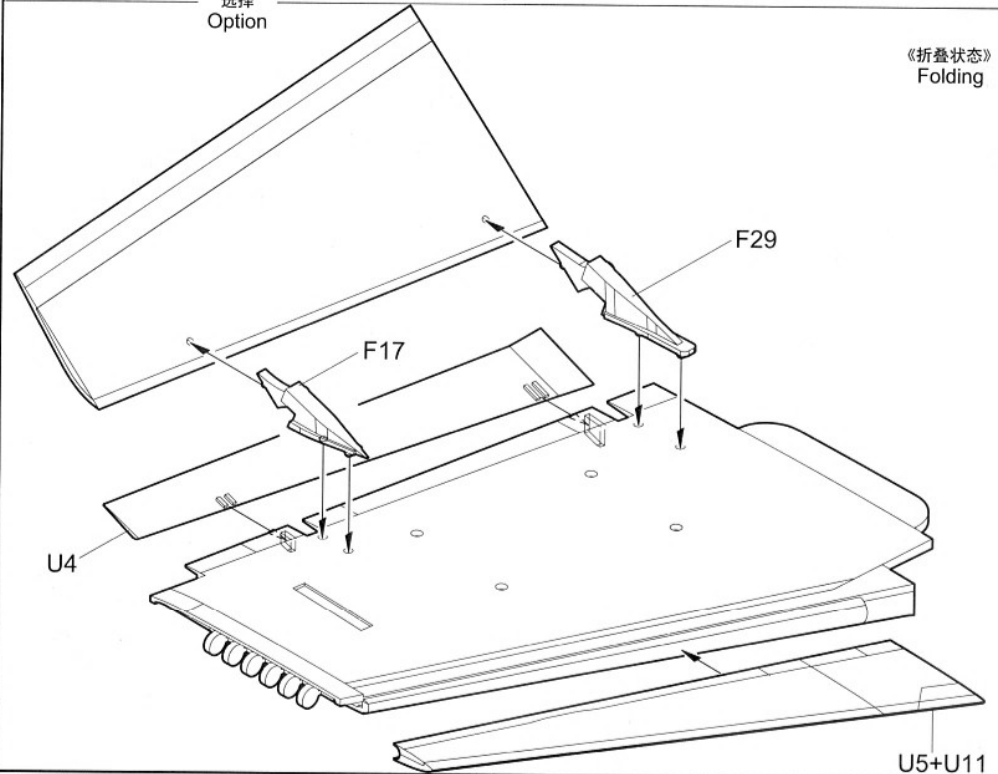

U5+U11

8

10

《左侧机翼》
Left wing

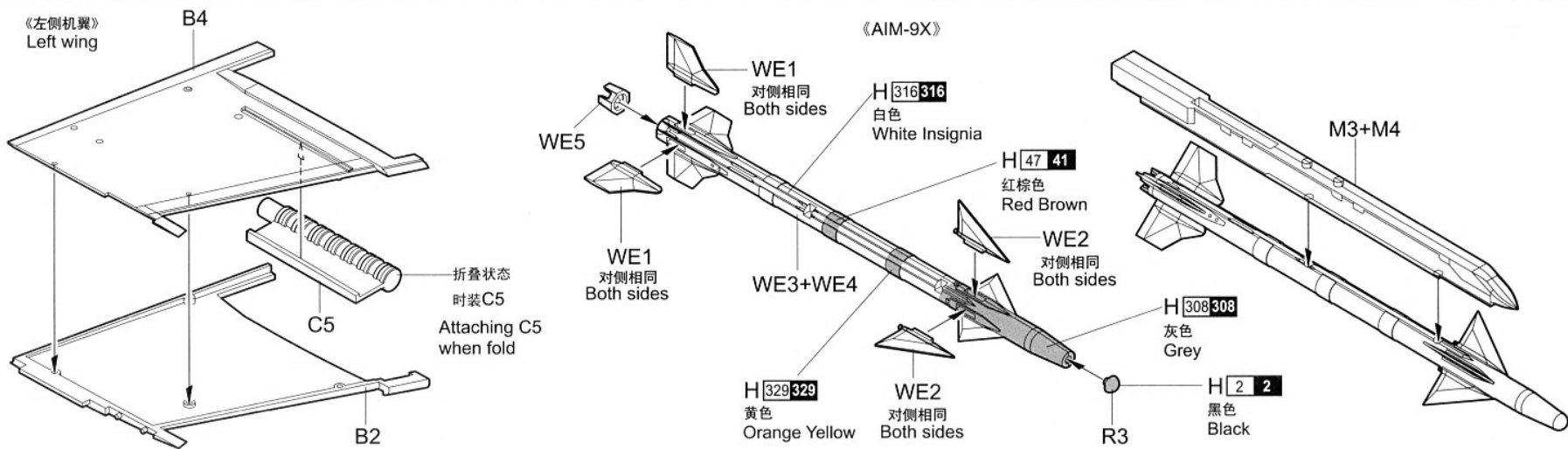

11

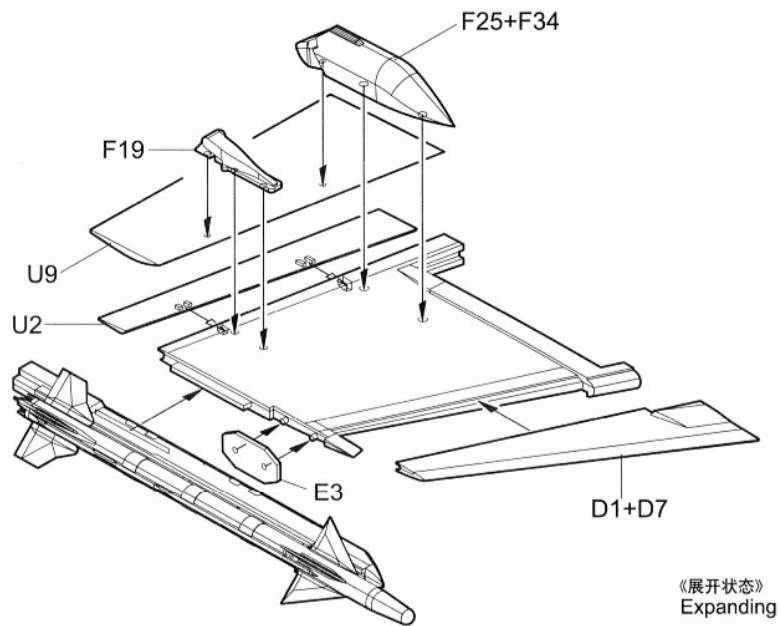

选择
Option

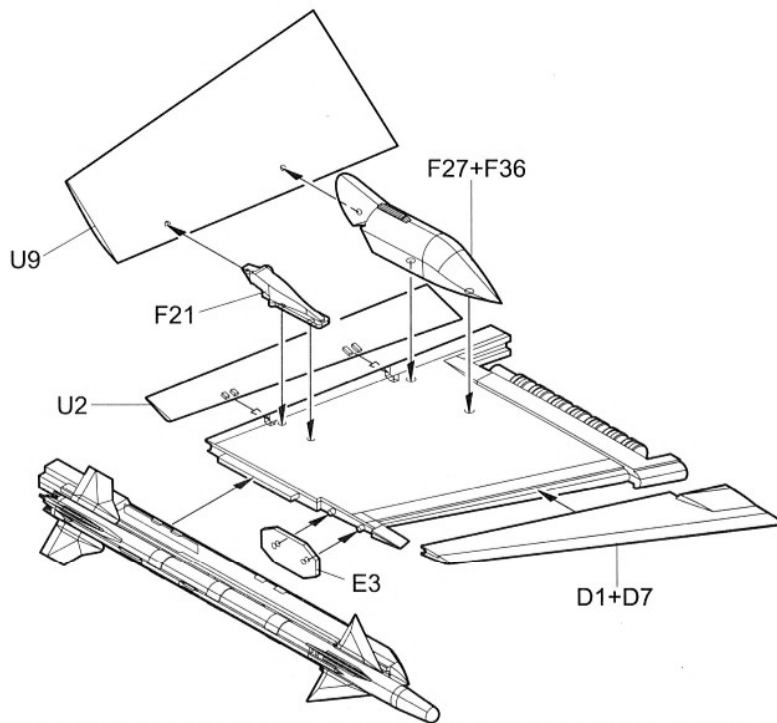

12

《右侧机翼》
Right wing

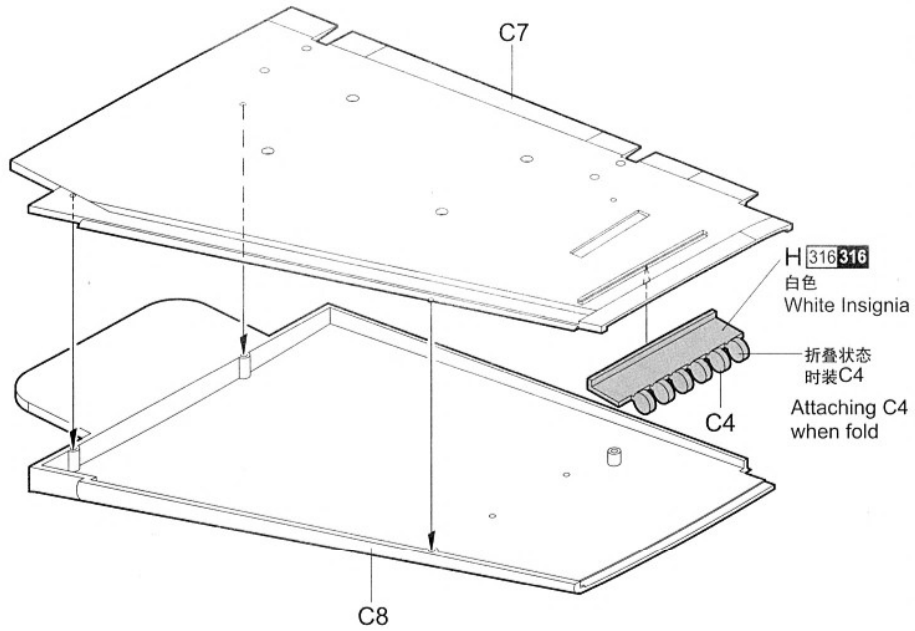
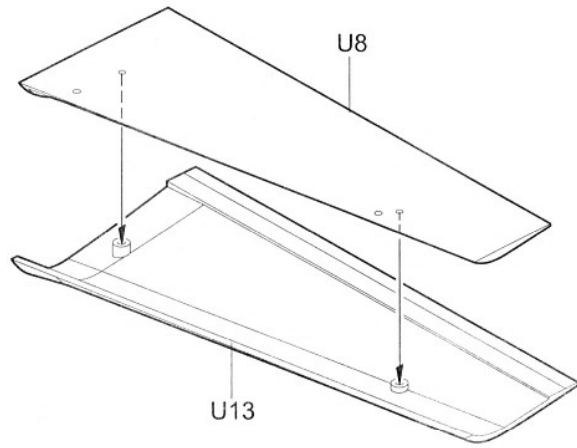

13

《展开状态》
Expanding

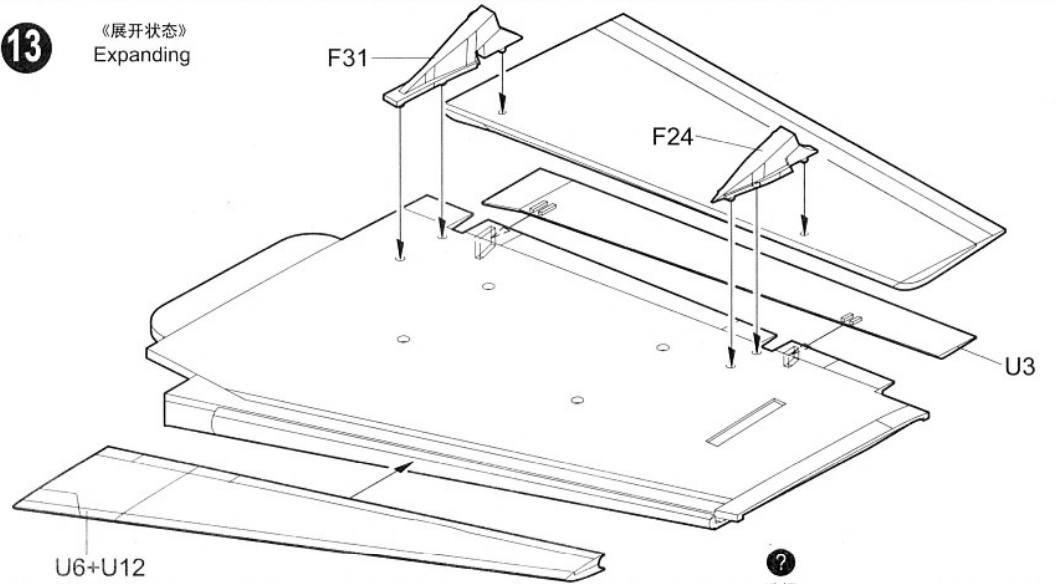

选择
Option

《折叠状态》
Folding

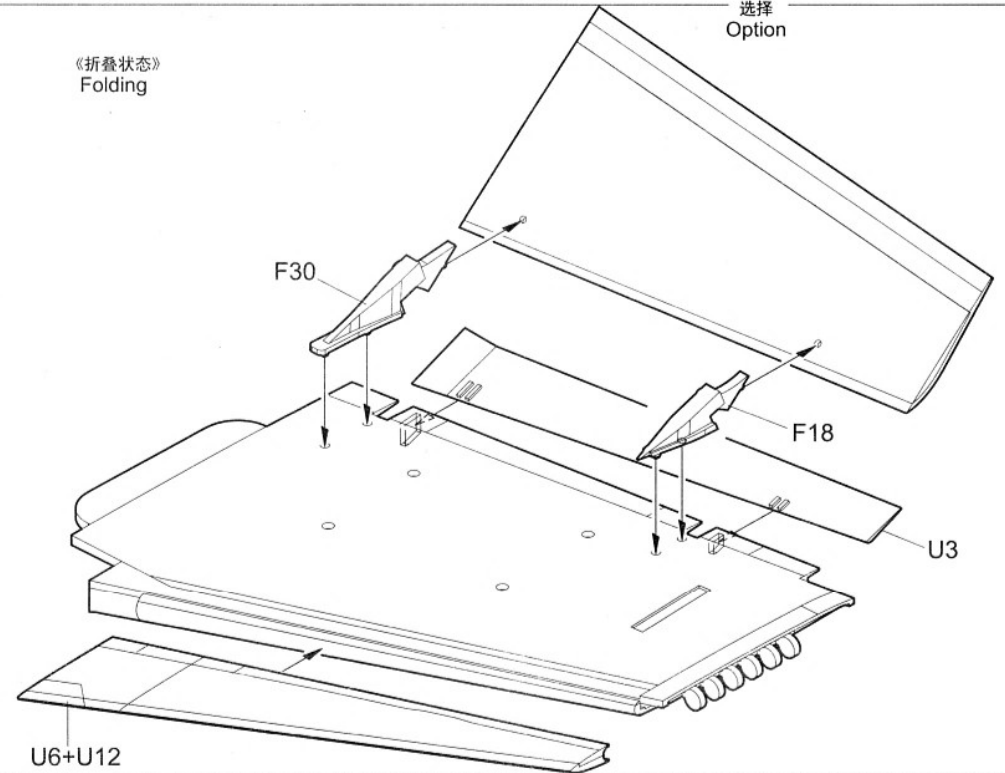

14

《右侧机翼》
Right wing

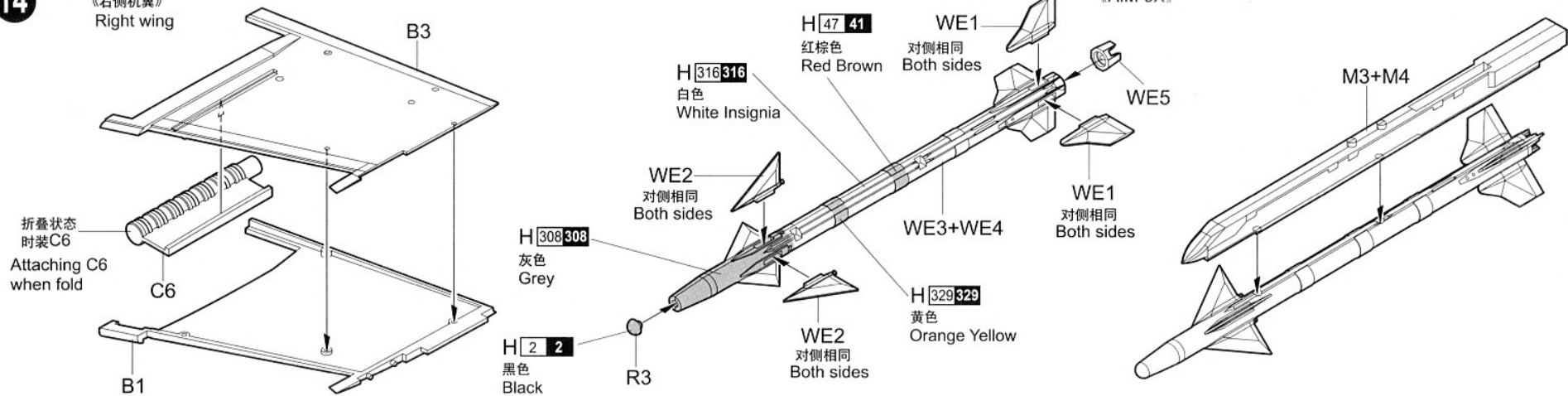

15

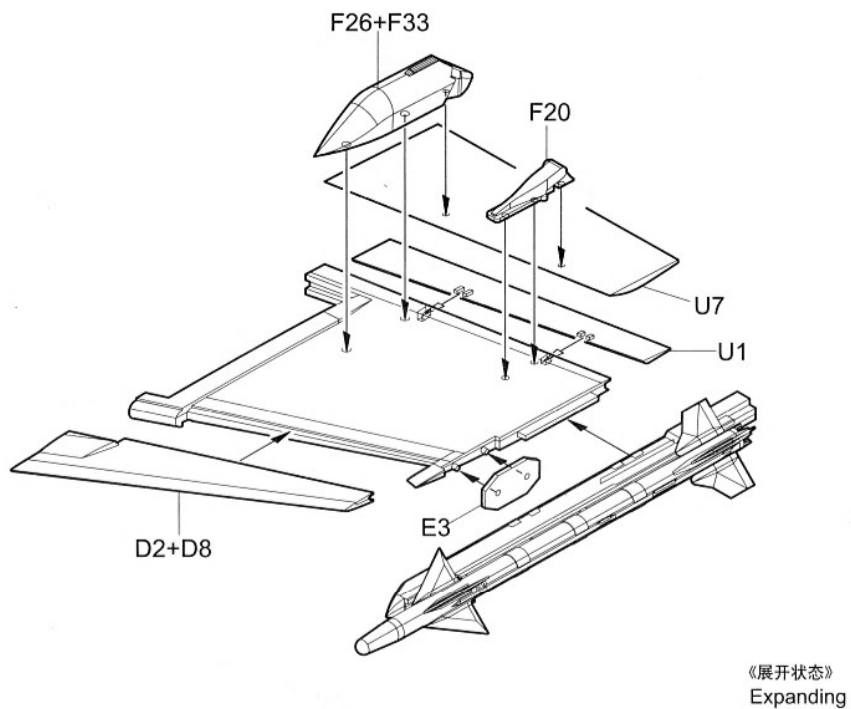

?
选择
Option

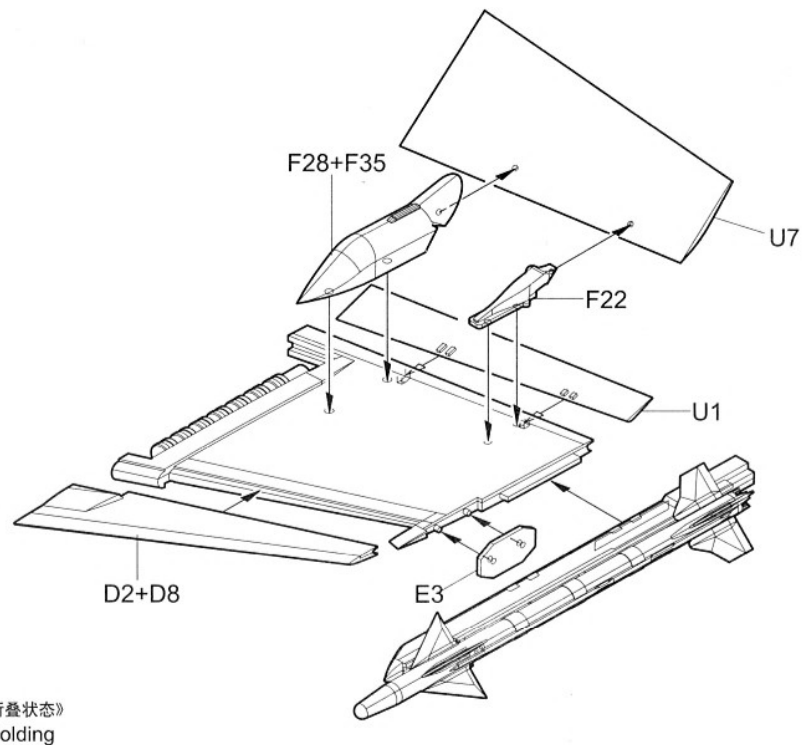

16

《左侧机翼》
Left wing

E9

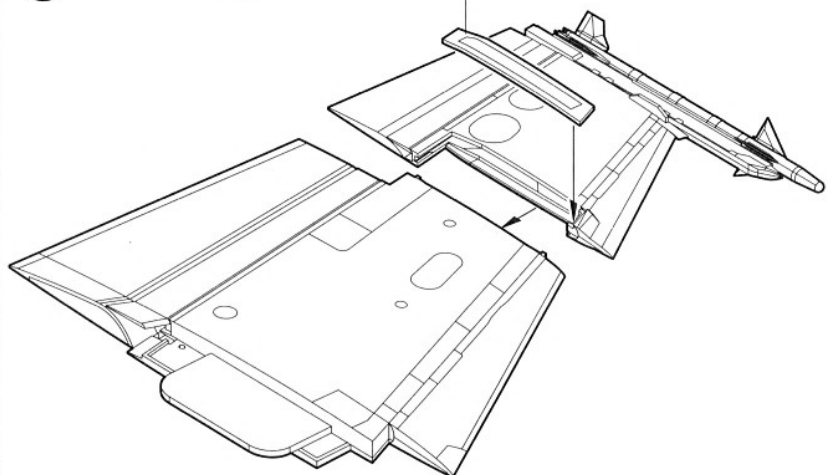

《展开状态》
Expanding

ⓧ
选择
Option

《折叠状态》
Folding

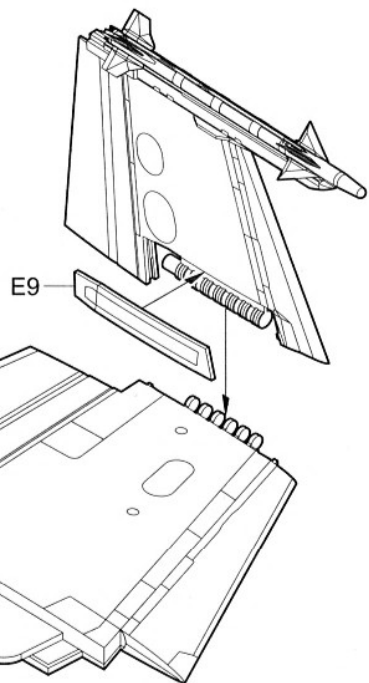

17

《右侧机翼》
Right wing

E8

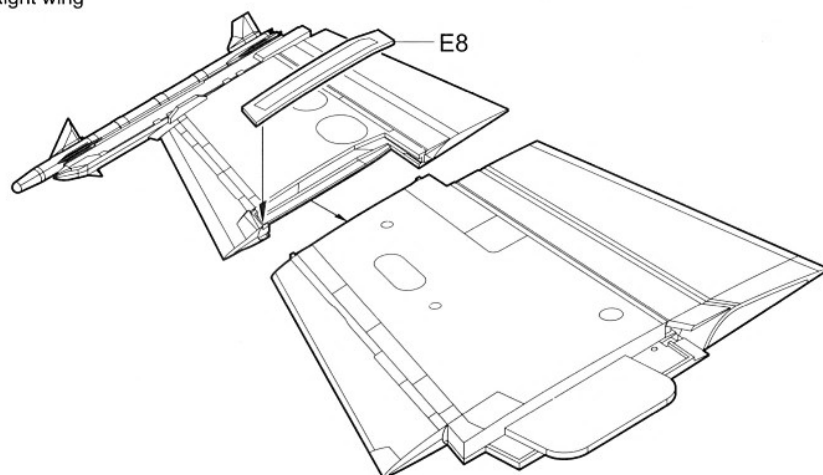

《展开状态》
Expanding

ⓧ
选择
Option

《折叠状态》
Folding

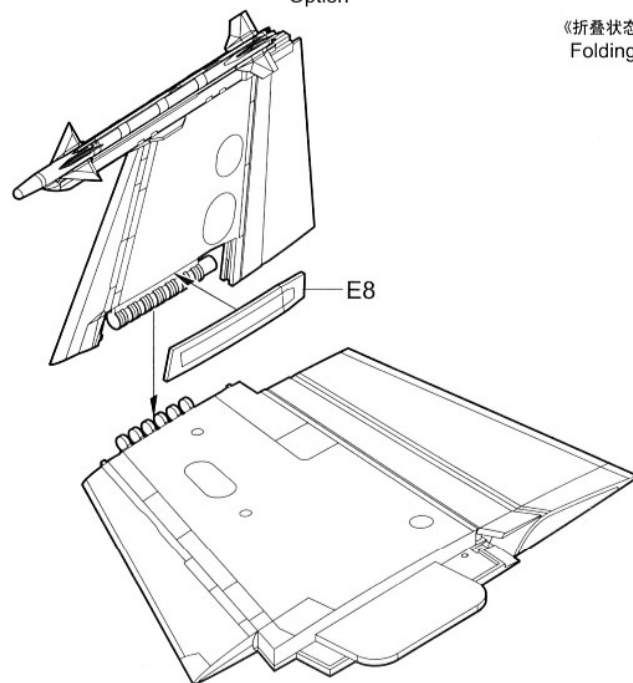

18

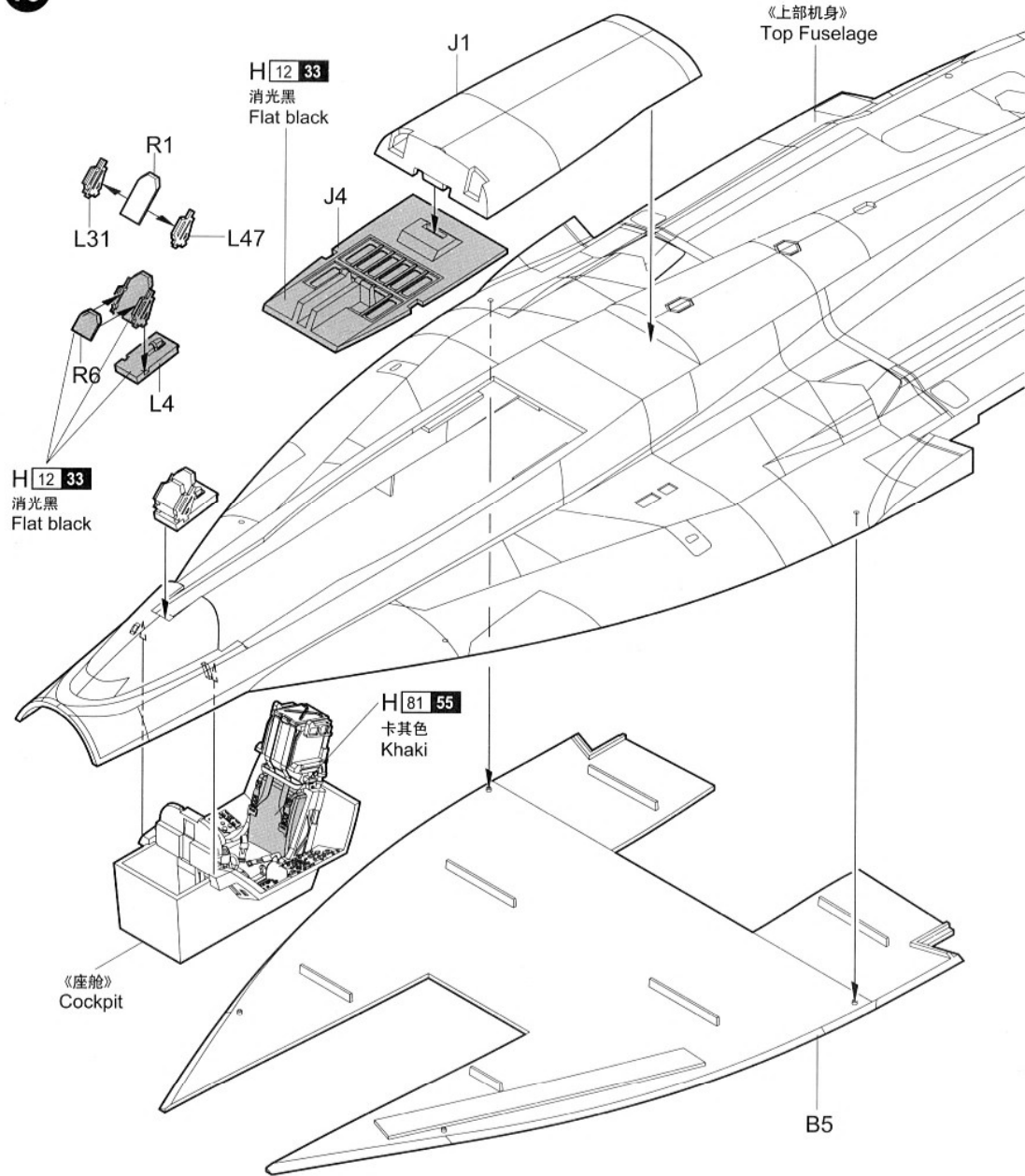

19

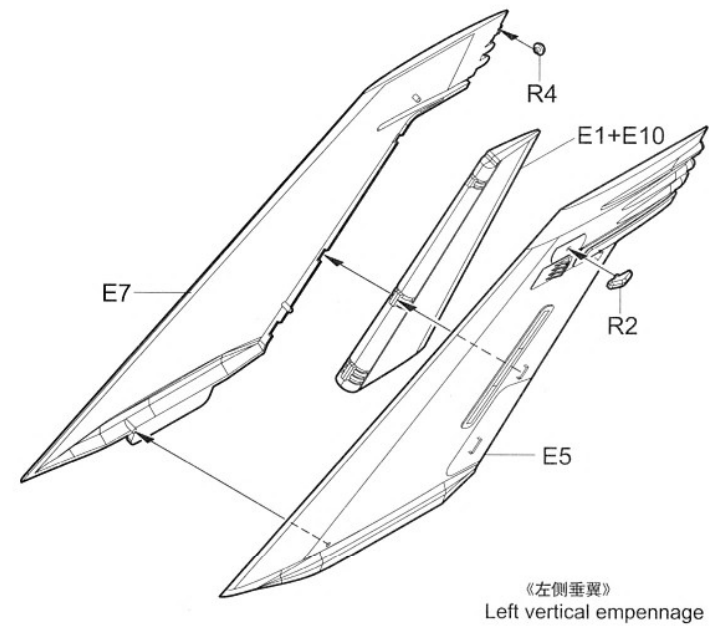

20

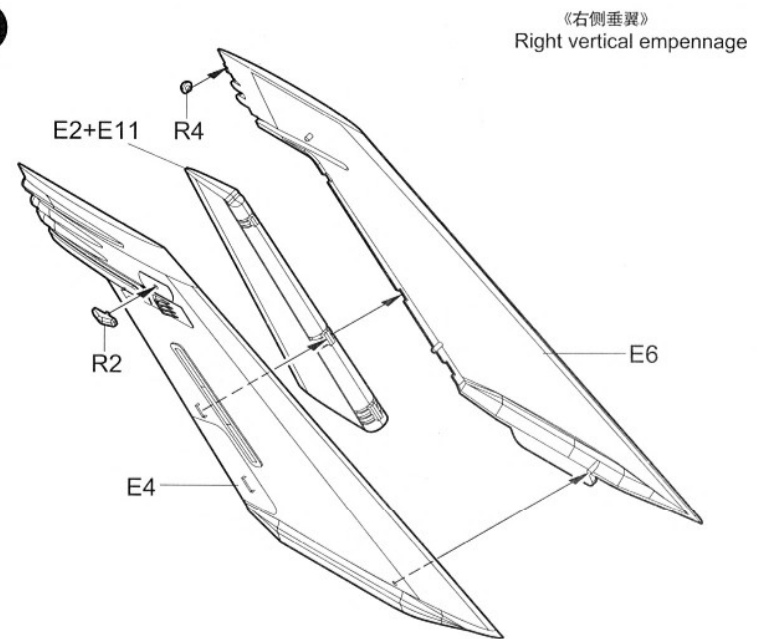

21

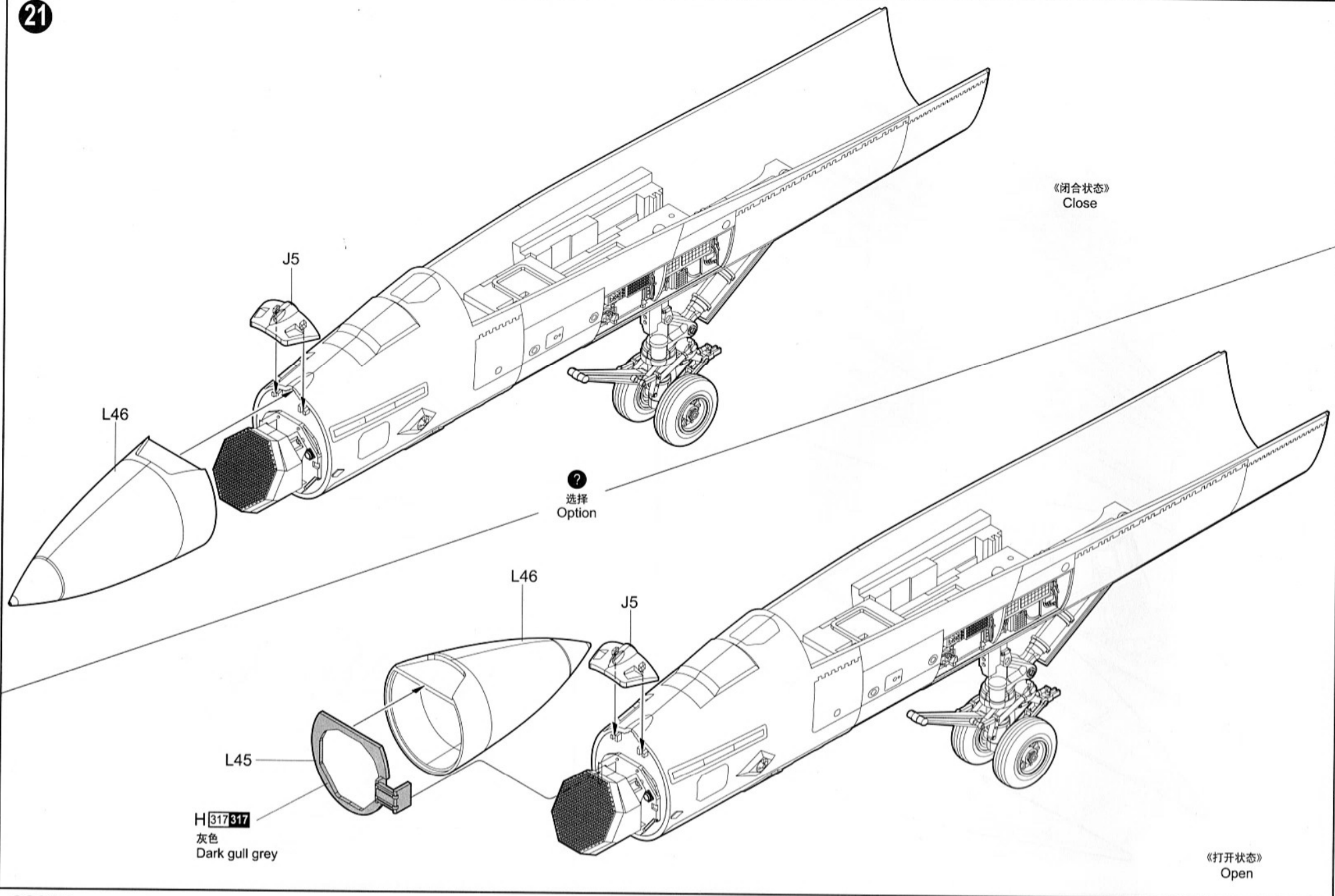

03204

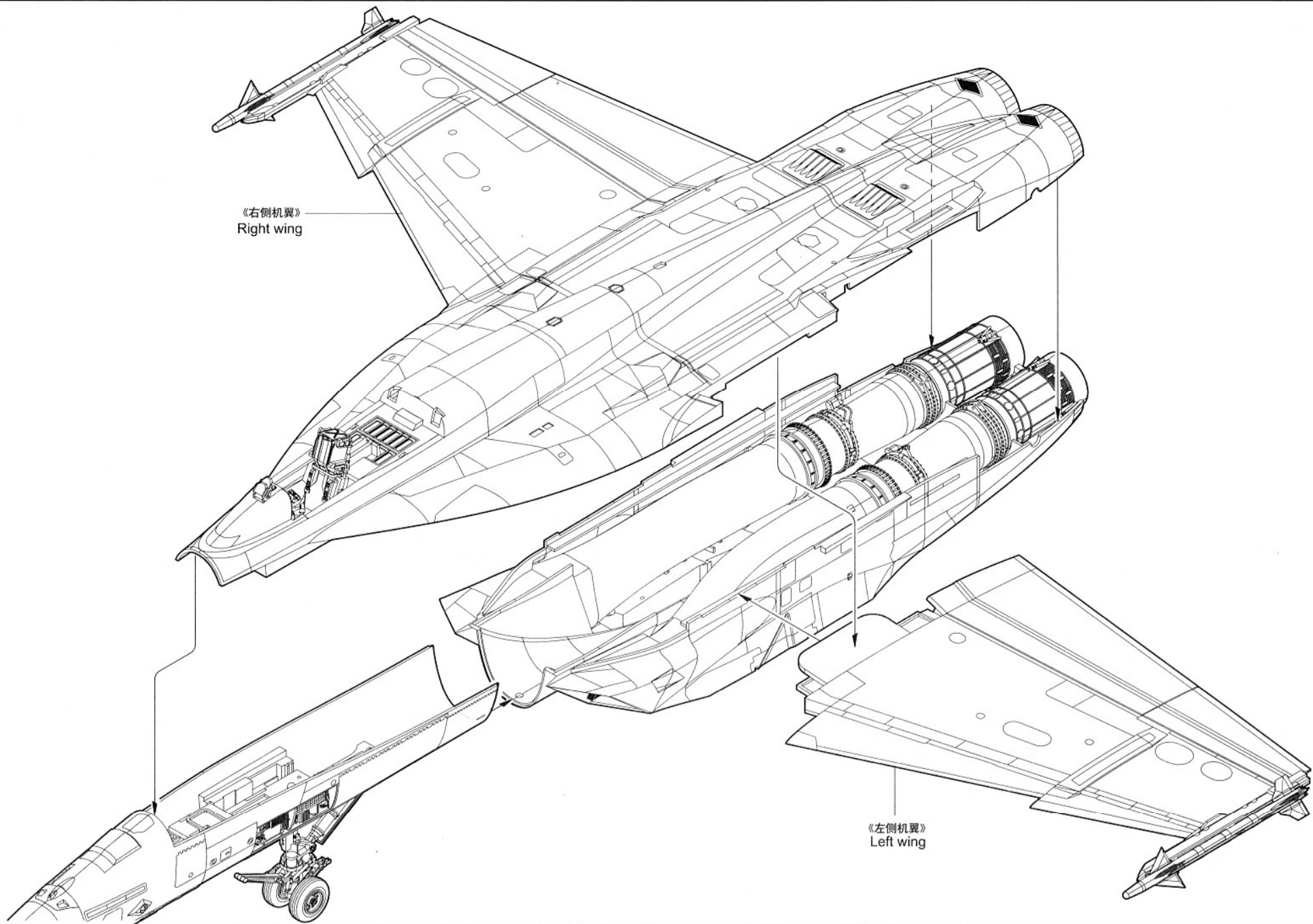

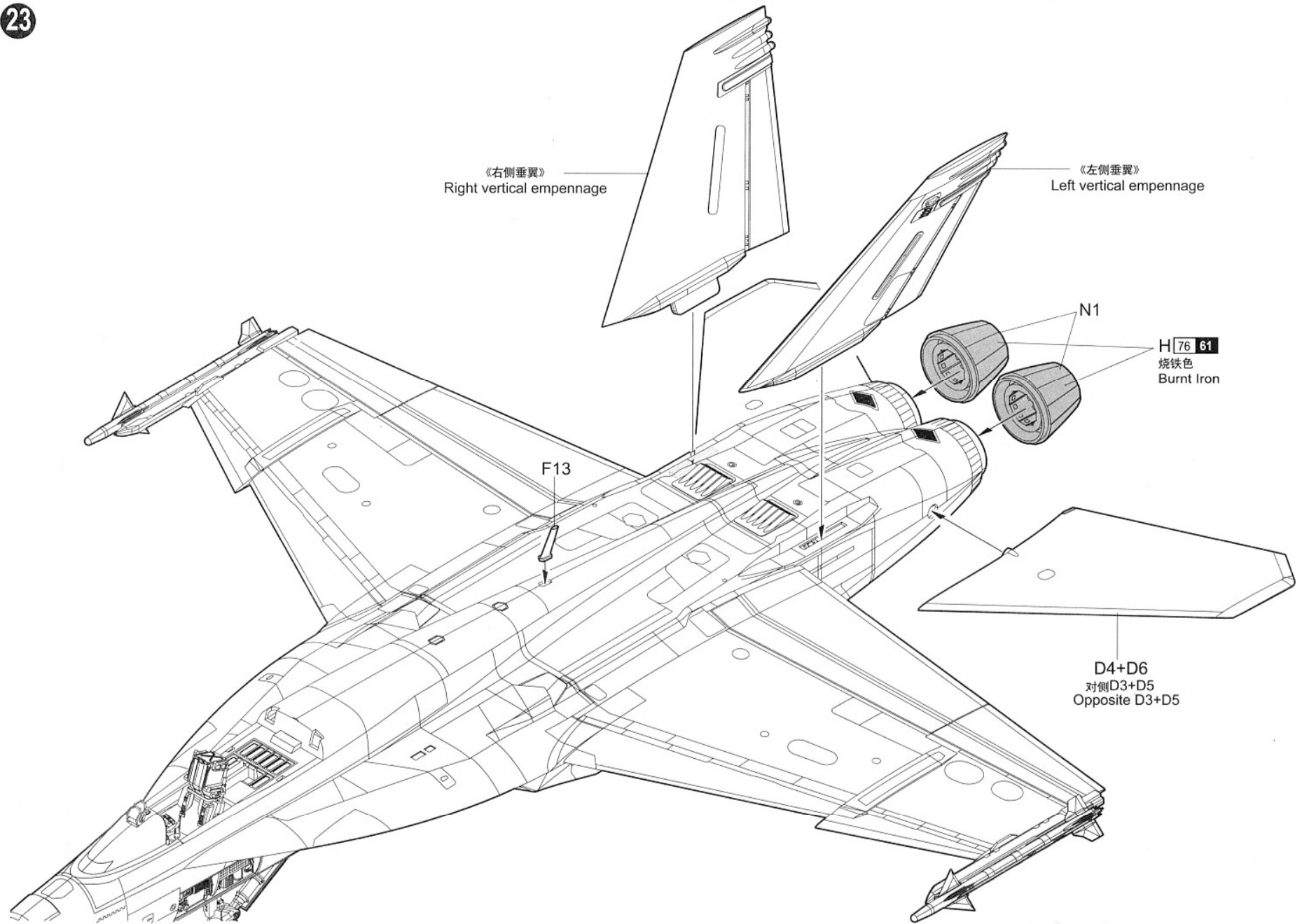

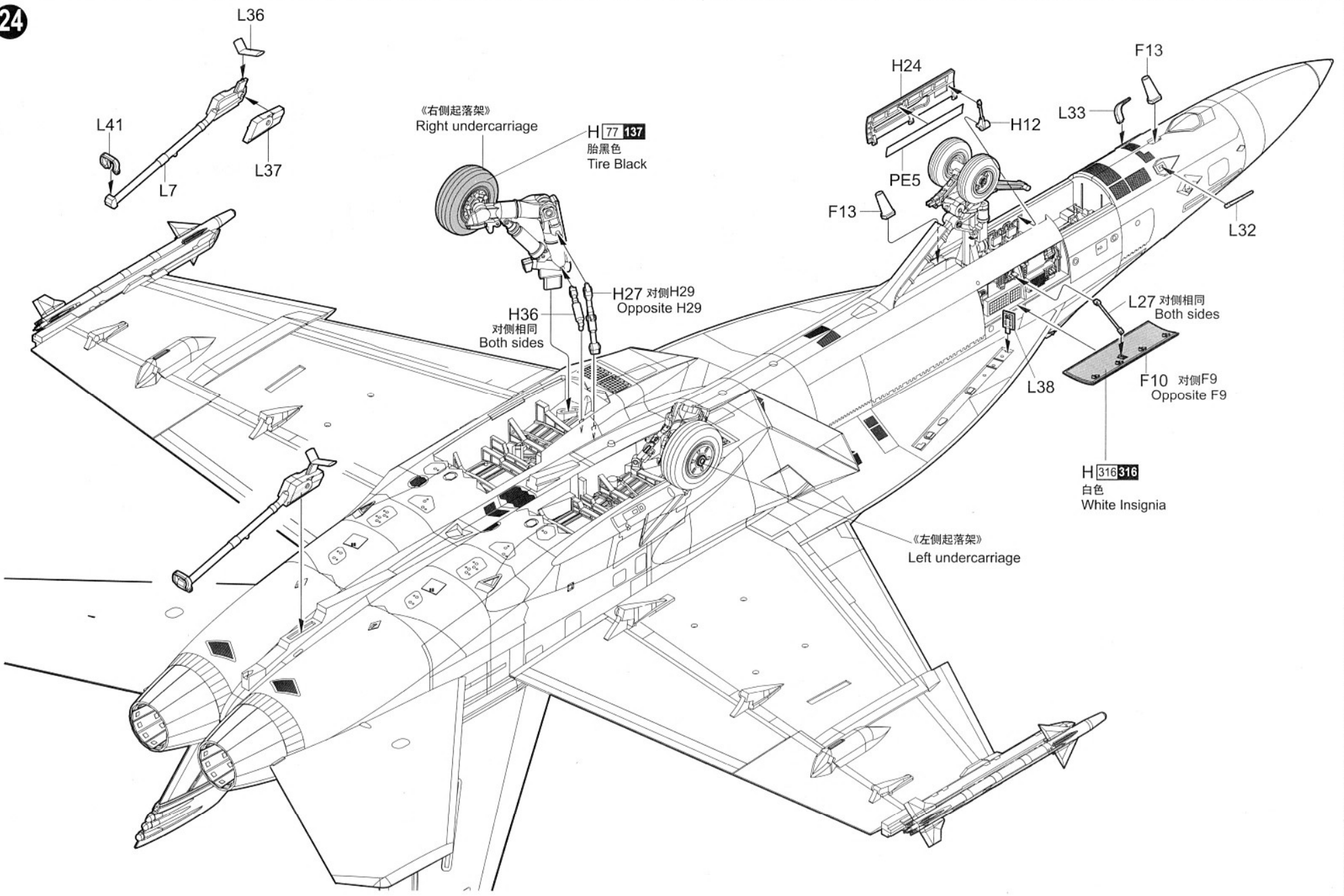

《右侧起落架》
Right undercarriage

H 77 137
胎黑色
Tire Black

《左侧起落架》
Left undercarriage

H 316 316
白色
White Insignia

25

H316316

白色
White Insignia

H30

?
选择
Option

H31

H23

H21

Opposite F7
对侧F7

F5 对侧F6
Opposite F6

Opposite F15
对侧F15

F14

Opposite F4
对侧F4

F3

H32 对侧H34
Opposite H34

H17 对侧H15
Opposite H15

H37
对侧相同
Both sides

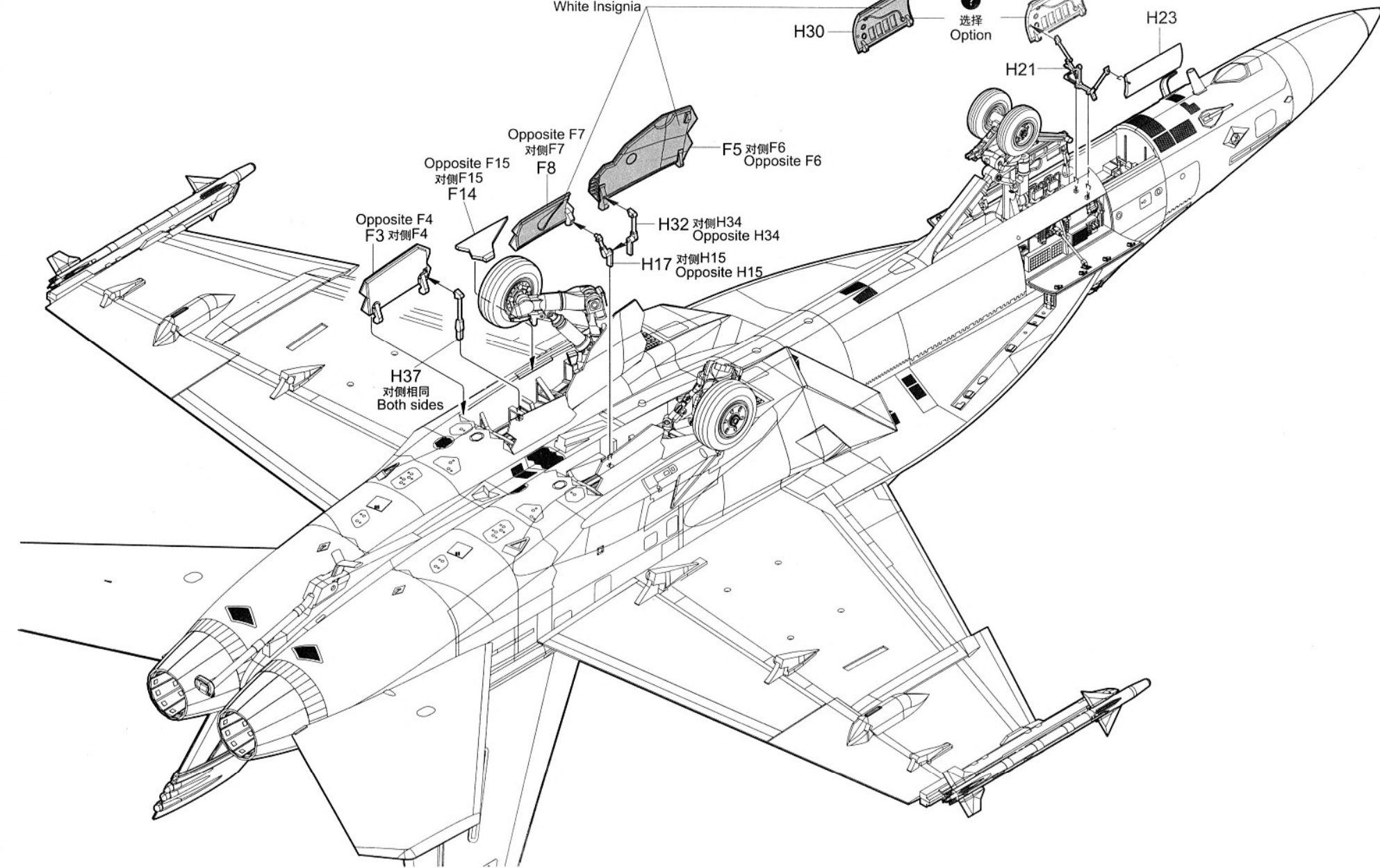

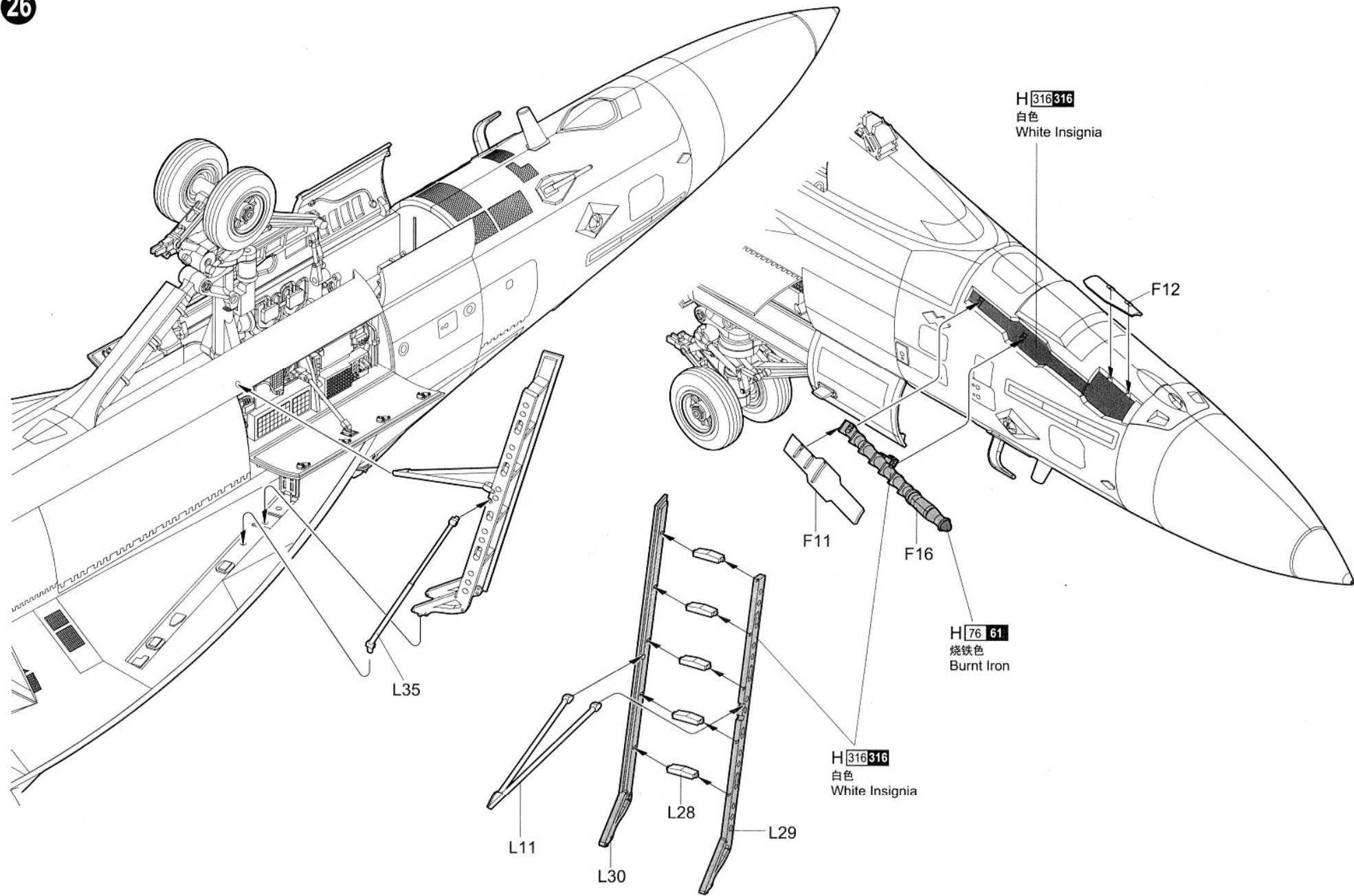

27

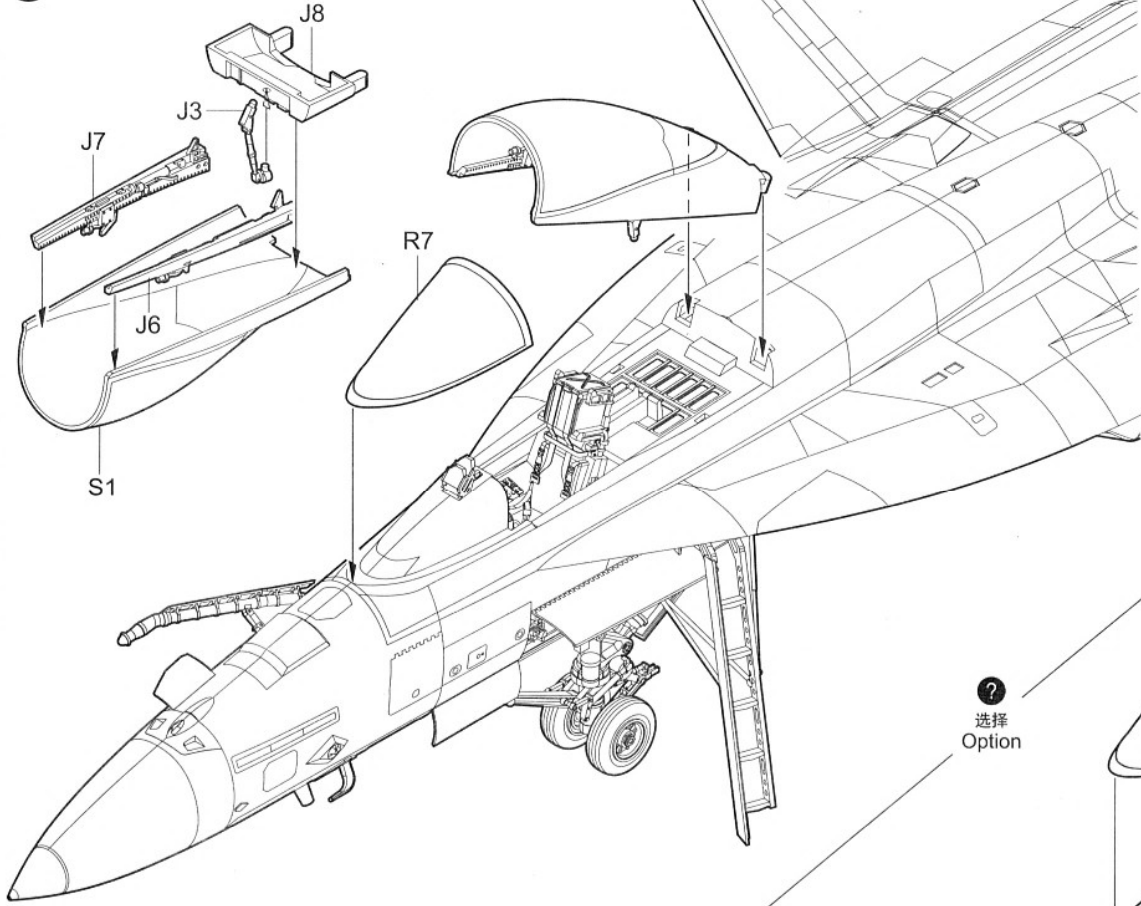

《打开状态》
Open

《闭合状态》
Close

②
选择
Option

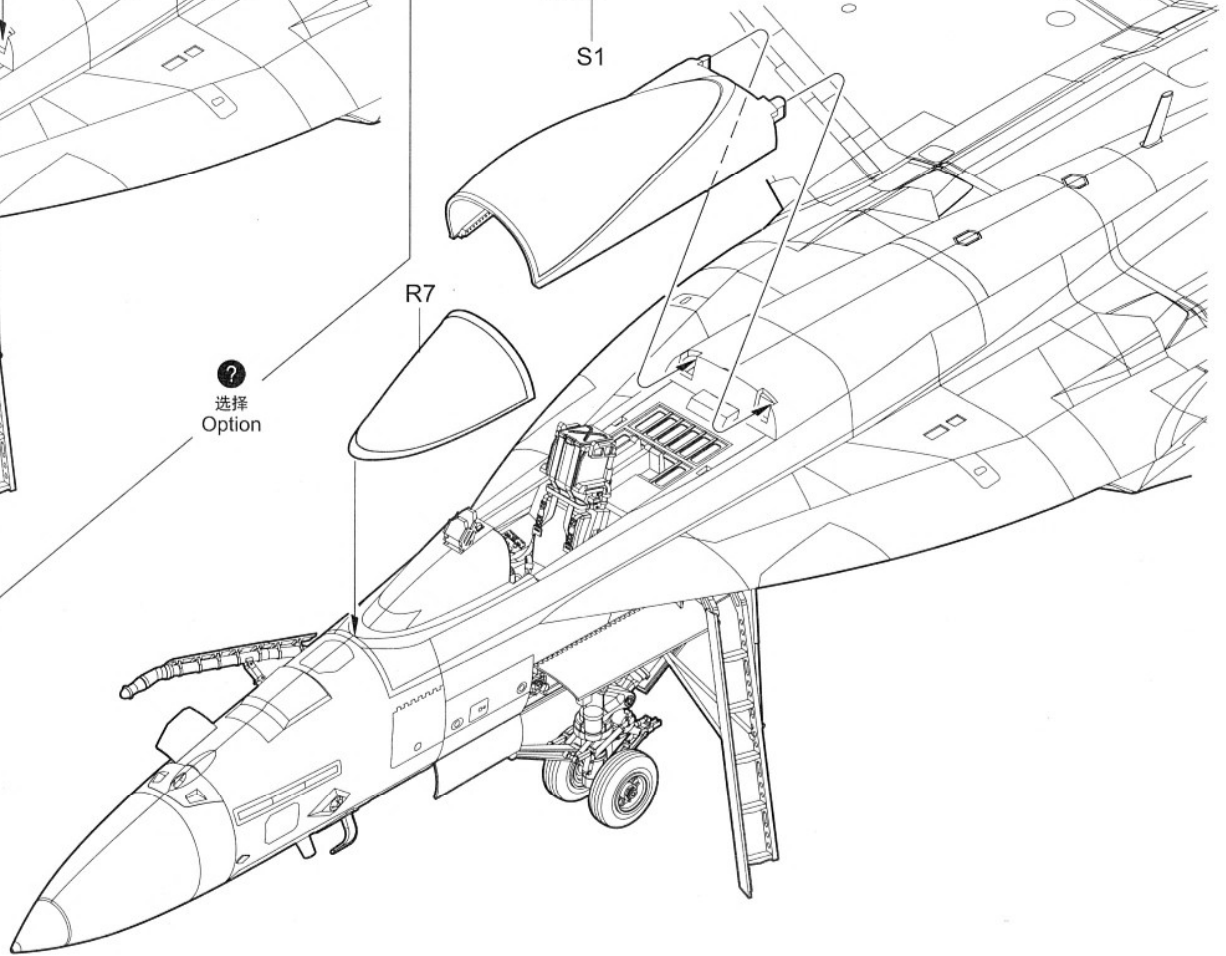
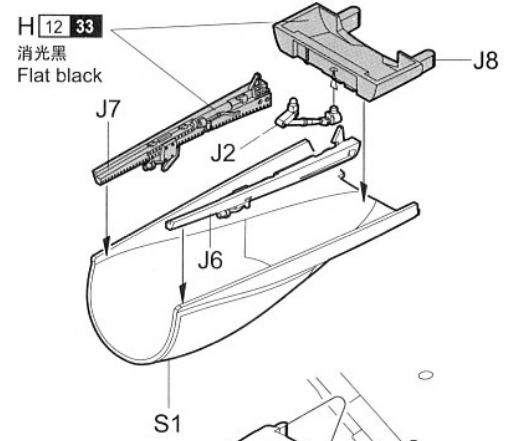

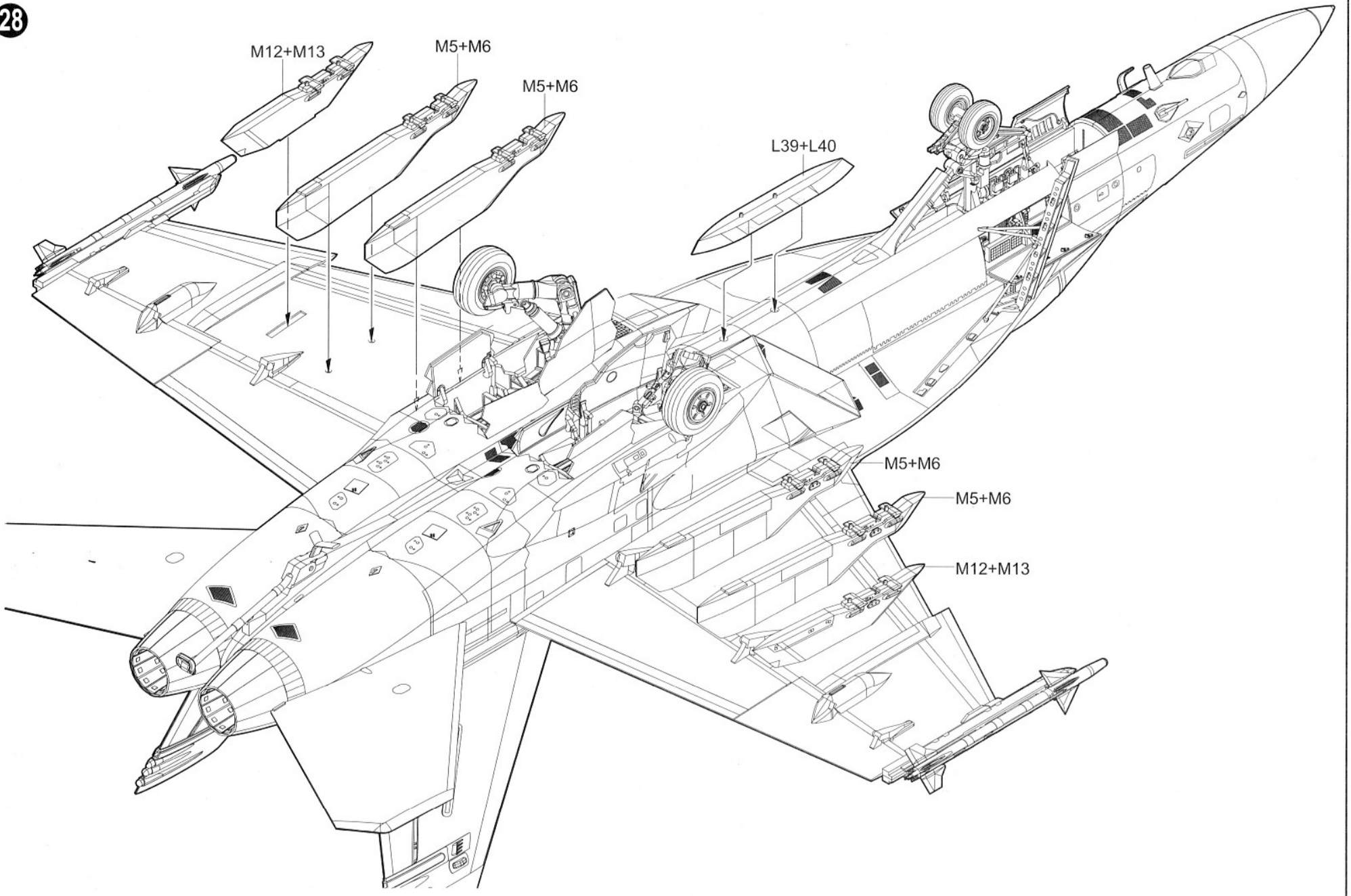

《Fuel Tank》

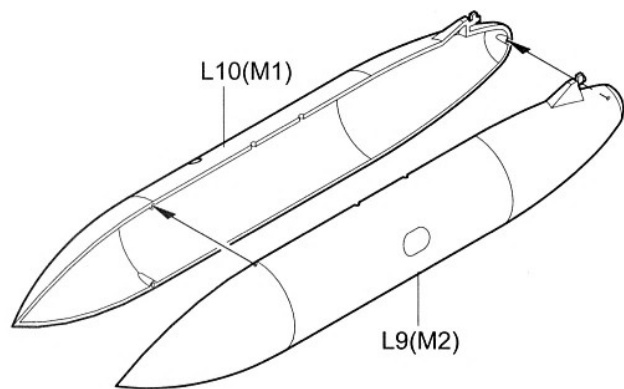

制作三组
Make three

《AIM-120》-A

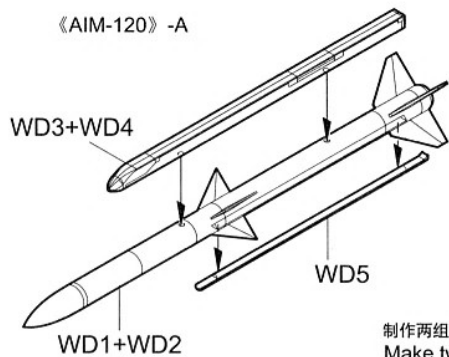

制作两组
Make two

《AIM-120》-B

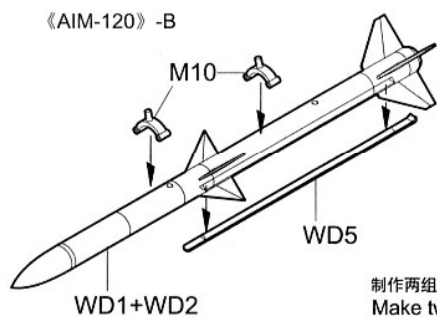

制作两组
Make two

《AGM-84H》

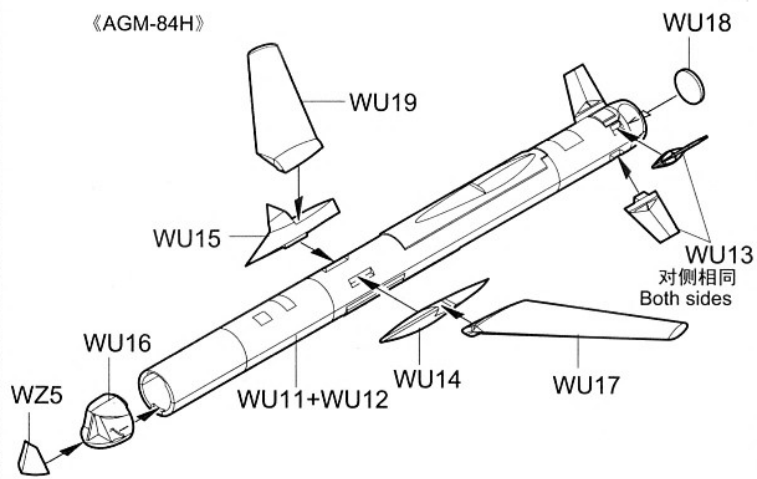

制作两组
Make two

《AGM-154》

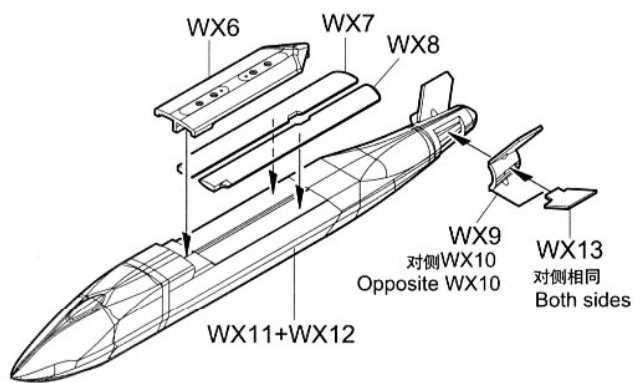

制作两组
Make two

《AGM-84A》

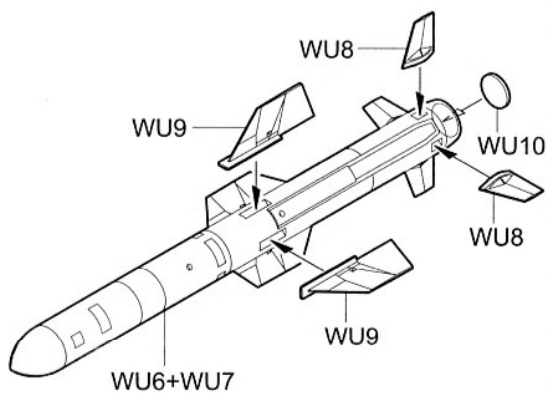

制作两组
Make two

《AGM-84E》

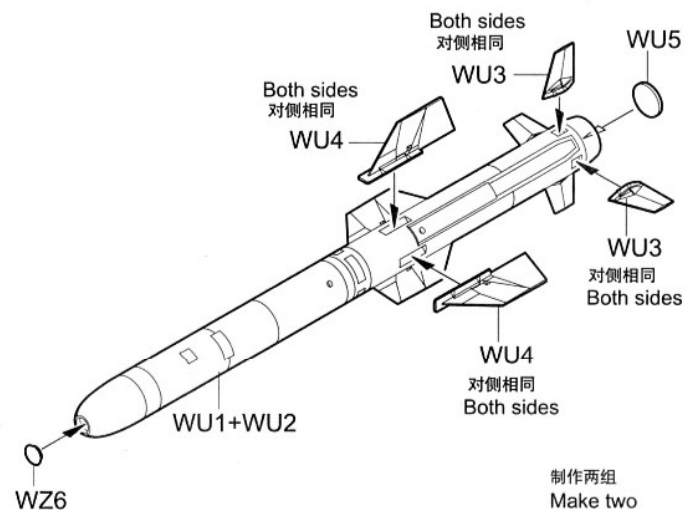

制作两组
Make two

30

《AN/AAQ-25》

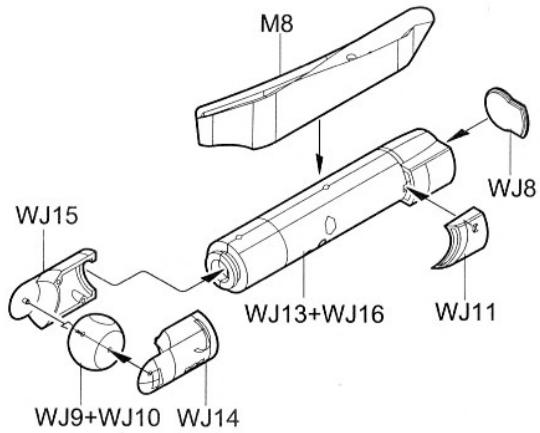

《LGTR》

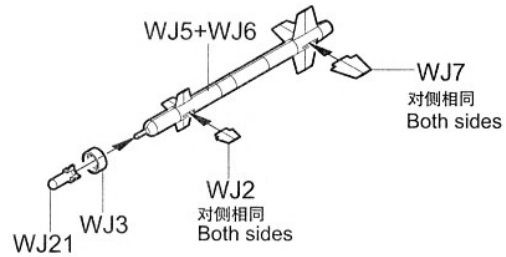

《MER》

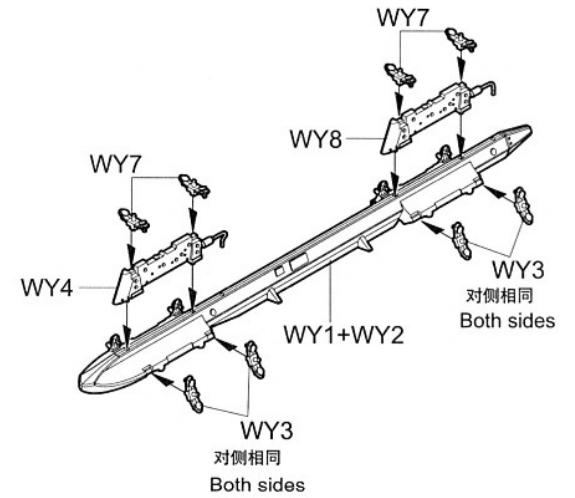

制作两组
Make two

制作两组
Make two

《AMD-141》

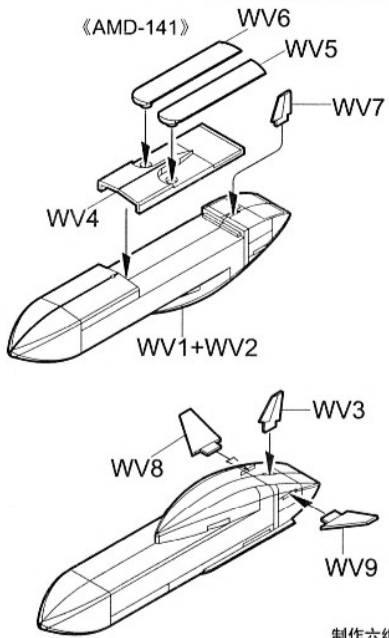

《GBU-22》

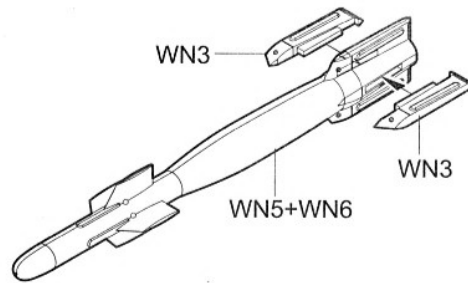

《GBU-12》

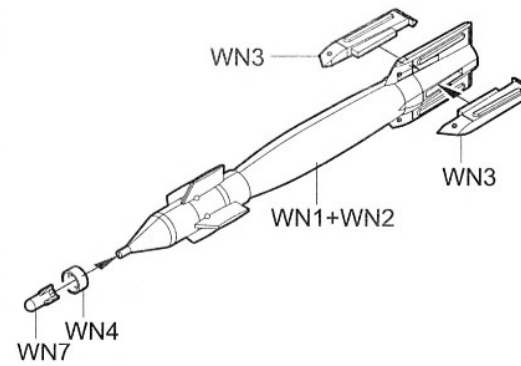

《TER》

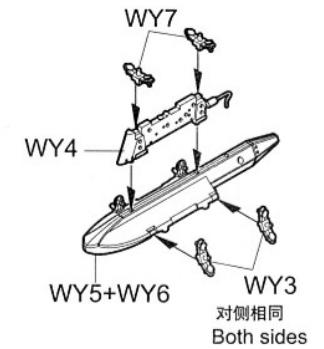

制作六组
Make six

制作六组
Make six

制作六组
Make six

制作两组
Make two

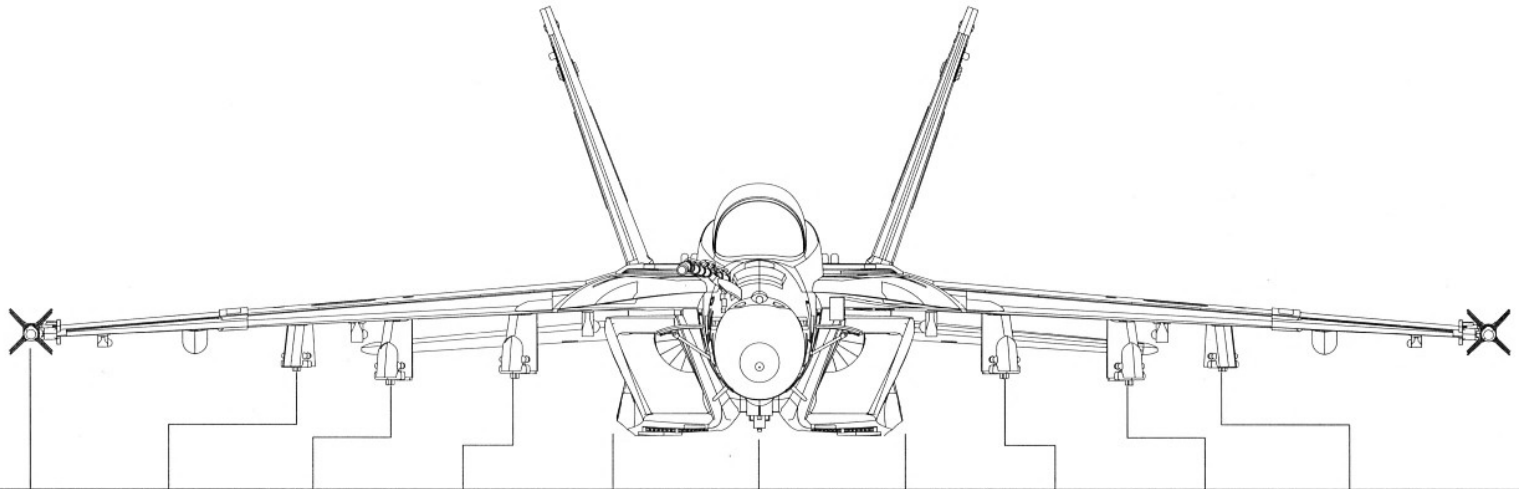

Sta.No.	1	2	3	4	5	6	7	8	9	10	11
Fuel Tank				●		●		●			
AIM-120				●	●		●	●			
AIM-9X	●										●
GBU-12				●●●				●●●			
GBU-22				●●●				●●●			
AGM-84A			●	●				●	●		
AGM-84E			●	●				●	●		
AGM-84H				●				●			
AMD-141			●●●						●●●		
AGM-154			●	●				●	●		
TER			●						●		
MER				●				●			
AN/AAQ-25							●				
LGTR			●	●				●	●		

涂装同标贴指示
Painting & Marking guide

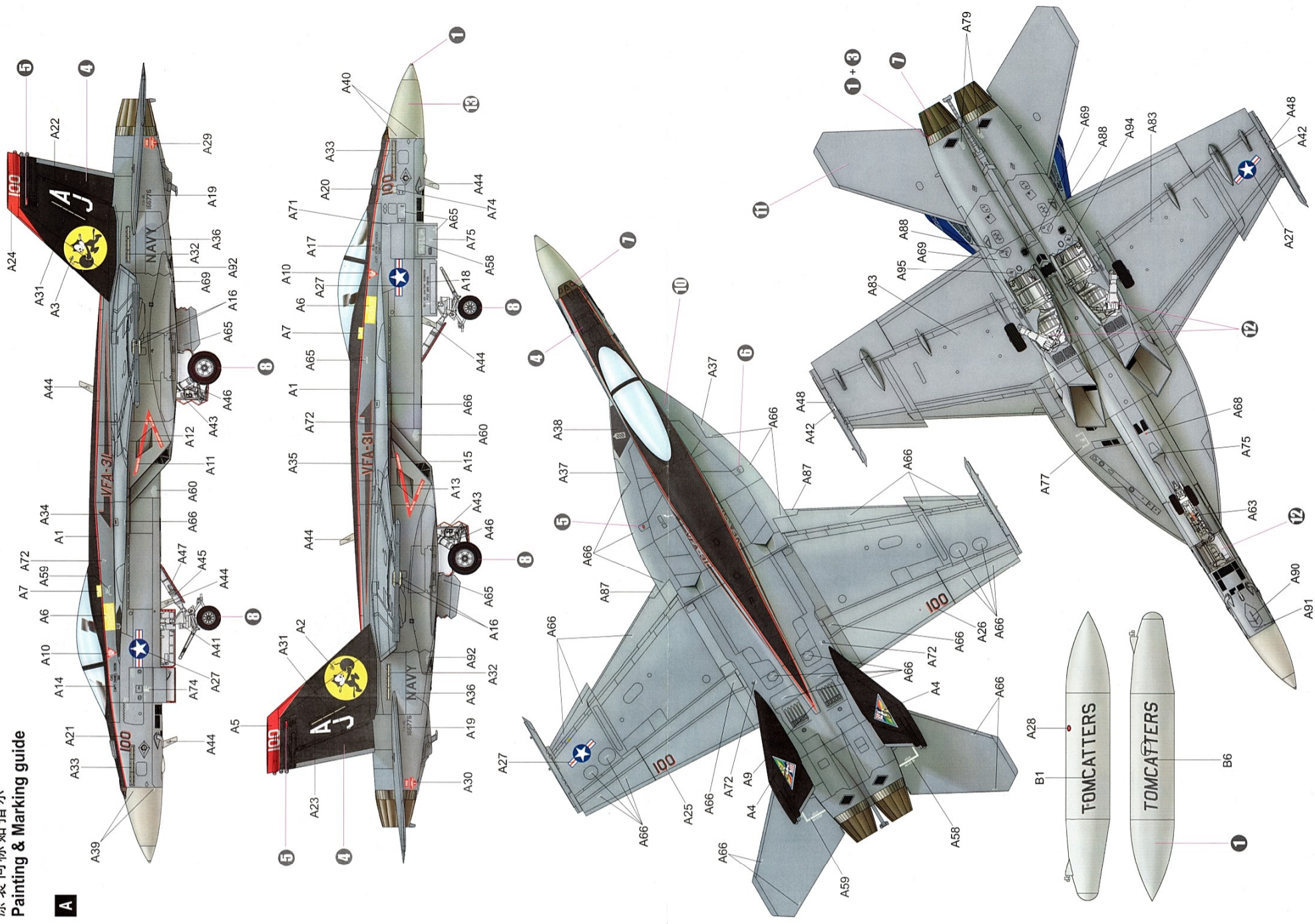

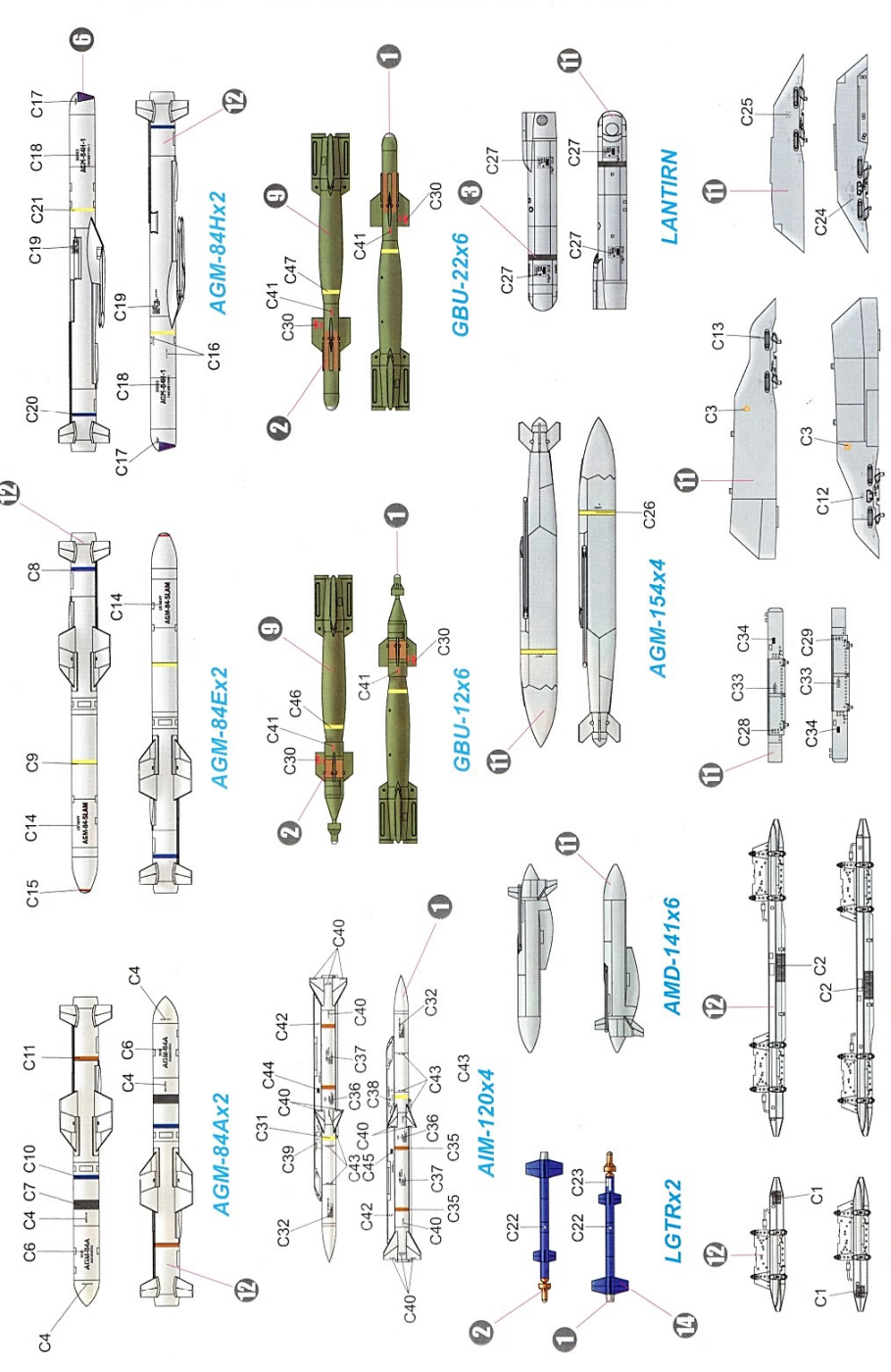
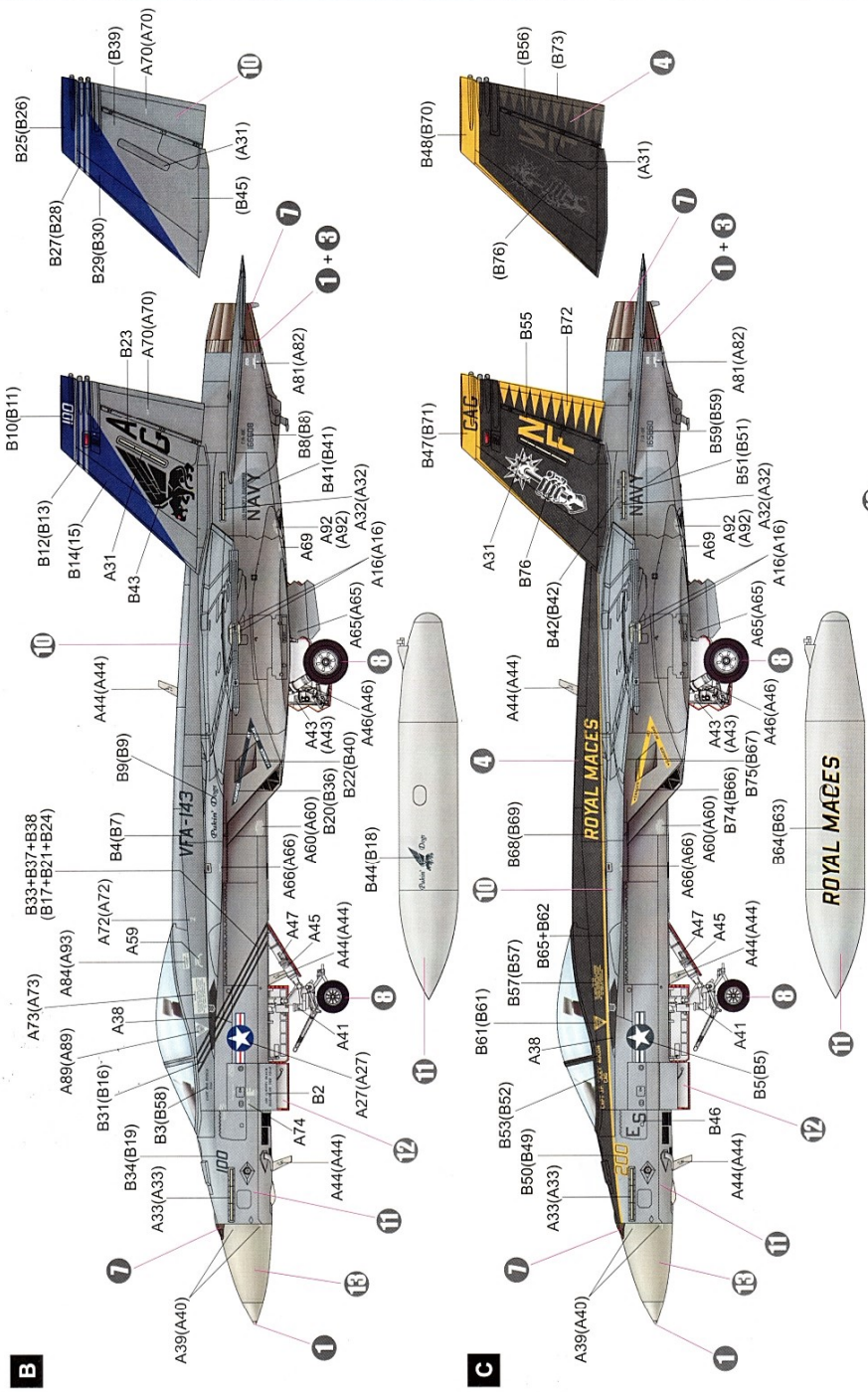

PAINT REFERENCE COLOUR

Color	Mr.Hobby	Vallejo	Model Master	Tamiya	Humbrol
1 Silver 银色	H 18 8	997	1546	X11	11
2 Copper 铜色	H 10 10	999	1551	XF6	12
3 Steel 黑色	H 18 28	864	1402	-	-
4 Flat Black 黑色	H 12 33	950	1749	XF1	33
5 Clear Red 透明红	H 50 47	934	-	X27	-

TERX2

MERX2

Color	Mr.Hobby	Vallejo	Model Master	Tamiya	Humbrol
6 Clear Blue 透明蓝	H 53 50	938	-	X23	-
7 Burned Iron 锈棕色	H 78 61	863	1795	X10	53
8 Tyre Black 轮胎黑	H 77 47	-	-	-	-
9 Olive Green 橄榄绿	H 50 504	887	1711	XF62	155
10 Ghost Grey 幽灵灰	H 50 507	-	1741	XF22	128

AQUEOUS HOBBY COLOR

Color	Mr.Hobby	Vallejo	Model Master	Tamiya	Humbrol
11 Grey 灰色	H 526 505	990	1728	XF19	127
12 White Insignia 白色	H 316 316	991	1745	X2	22
13 Light Blue 浅蓝色	H 318 318	917	1709	-	148
14 Light Blue 浅蓝色	H 326 326	-	1719	XF17	189

Mr. COLOR