

Churchill Mk III TLC Laying Device and Carpet (Type D)

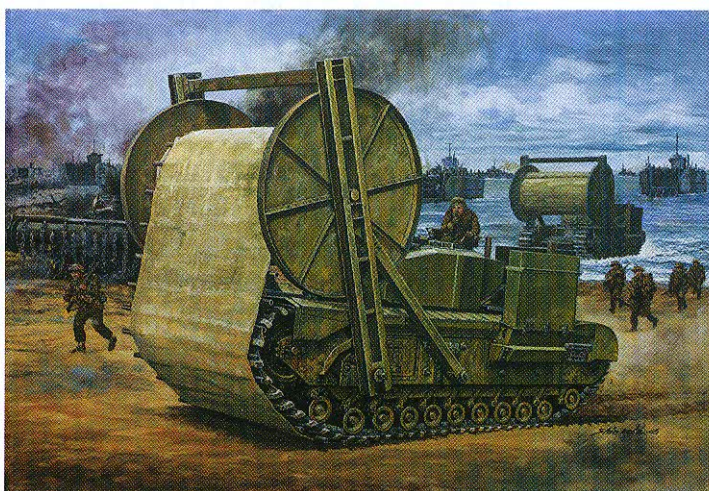

** Special thanks from the bottom of our heart to:
Mr. Ossie Orsourn · Mr. Robin Buckland

August in 1942, to relieve pressure of USSR on the Eastern Front. A ground force consisted of Canadian Army, Royal Navy and Royal Air force. They chose a French port - Dieppe to attempt an experimental landing. This operation was originally set as "regional scale". The whole landing troops were less than 10,000 people, including the Calgary Regiment consisted of 29 Churchill infantry tanks.

To overcome the shingles all over the Dieppe beach, this operation they were accompanied with AVRE tanks modified from Churchill tanks. 5 of Churchill tanks were equipped with "Bobbin" supported by a frame of steel pipes in the front of the tanks. The Bobbin was used to lay carpet made from coconut fiber. This carpet could disperse pressure that tanks made onto the ground. Let the tanks pass without being bogged down in the soft shingle beach. However, the structure of these steel pipe frames were too fragile. They were damaged during shipping and later combat. They didn't work out as they were expected. This failed landing operation provided precious experience for creating the second front on the west. The main objective was to prevent landing troops from being stuck on the beach by obstacles and enemy fire.

In the march, 1943, the British Chief of Defense Staff approved the proposal of Army Major General Percy Hobart. His project was to design special AVRE combat support vehicles. This way it can clear minefield in landing operation and lead following troops cross obstacles also providing suppressive fire on German troops.

Development of Churchill tanks with carpet layer device continued in General Hobart's 79th armored division. It had developed many variants. Some of them laid fascine. Some of them used canvas as carpet. Some of them used canvas cloth reinforced with steel poles. On the D Day of Normandy Landing, those Churchill tanks with carpet layer device proved themselves effective and created 7 paths for tanks on the soft ground of Gold Beach. Let the British 7th Armored Division of next wave land successfully.

1942年8月、東部戦線で戦うソビエト軍への圧力を減少させるために、いわゆる第二戦線を展開するべく、カナダ陸軍、英海軍、英空軍から成るひとつの部隊が編成された。彼らは、上陸作戦の経験を積む実験的な戦闘の舞台として、フランスの港町ディエップを選択した。もともとこの作戦は局地的な規模のものとして計画され、上陸軍全体の兵員は一万名以下、カルガリー連隊が29輦のチャーチル歩兵戦車を装備して参加していた。

全体が小石で覆われたディエップの海岸に上陸するために、作戦にはチャーチル戦車を改造した工兵戦闘車 AVRE が随伴した。5輦のチャーチル戦車が、車体前面に鉄パイプ製のフレームに支えられた巨大な糸巻き状のコイル"ボビン"を装着、ボビンに巻かれたココナツ繊維製カーペットを敷く役割を持っていた。このカーペットが戦車の接地圧を低減し、小石の海岸にのめり込むことなく通過させられるはずであった。しかし、鉄パイプ製のフレームが壊れやすく、海上輸送中や戦闘後に損傷してしまい、期待された効果を発揮できなかった。ディエップ上陸作戦での失敗はヨーロッパ西部で第二戦線を構築する上で貴重な教訓をもたらした。上陸作戦の成功のカギは、部隊が障害物や敵の銃火によって海岸で立ち往生するのをいかに防ぐかにかかっていると認識されたのだった。

1943年3月、イギリス国防参謀総長はパーシー・ホバート少将の提案を承認した。彼の計画は、特別な工兵戦闘車を製造するというもので、上陸作戦時に地雷原を排除、障害物を乗り越えながら敵に制圧射撃を加え、後続の上陸部隊を先導するというものであった。

新たなカーペトレイヤー装備のチャーチル戦車の開発は、ホバート少将の第79機甲師団において進められ、多くのバリエーションが開発された。粗朶(そだ)束を装備したもの。カーペットにキャンバスを採用したもの。また鉄のポールで補強されたキャンバスを装備したものなどその形態は様々であった。ノルマンディ上陸作戦 D-Day において、これらカーペトレイヤー装備のチャーチル戦車はその威力を発揮し、ゴールドビーチの軟弱な砂地に7本の戦車上陸路を開拓、後に続く英第7機甲師団の上陸を成功に導いたのであった。

1942年8月，為了緩解德蘇戰線上蘇聯所面臨的嚴峻壓力，以加拿大陸軍為主的地面部隊，配合著皇家海空軍，在法國臨近英吉利海峽的海港第厄普進行了一次試探性的登陸，由於行動的作為在一開始就是被設定是“局部”的，因此參與的登陸部隊規模尚不及萬人，其中包括了一支由29輛邱吉爾步兵戰車所組成的卡爾加里戰車團。為了克服第厄普海灘遍布的卵石，這次作戰有了由邱吉爾戰車所改裝的工兵車輛隨行--五輛邱吉爾在車輛前端以簡單的鷹架鋼管組成骨架支撐著“線軸”，用來鋪設由椰殼纖維製成的地毯，由地毯來分散接地壓力，讓接下來通過的戰車不致於陷入卵石堆之中。但由於這些鋼管骨架的結構脆弱，在海運及稍後的戰鬥中受到損壞，並沒有發揮原先想定的功能。

這次失敗的登陸行動為爾後的開闢第二戰場的行動取得了許多寶貴的經驗，為避免登陸部隊一上岸便被障礙物及火網困在灘頭之上，1943年3月英國參謀總長批准了陸軍少將霍巴特的建議，計畫研製各式特種工兵支援車輛，以俾使在登陸之時能率先清除雷區，帶領部隊通過障礙物並適時壓制德軍火力。

鋪地毯的邱吉爾戰車在霍巴特少將的第79裝甲師中獲得繼續的發展，並存在著許多不同的形式。有些以木柴鋪墊在地面，有些改採帆布做為地毯的材質，有些更襯以鋼管來增強地毯的強度，在諾曼地登陸時，這種線軸邱吉爾戰車在土質鬆軟的黃金海灘充分的發揮了它的作用，開闢了七條能夠讓戰車在海灘通行的通路，讓稍後第二梯隊的英國第七裝甲師於此處順利登岸。

Illustration:圖示說明



Method For Applying Decals:

1. Clean Model Surface With Wet Cloth.
2. Cut Out Of Decal Sheet And Dip Them In Water For 15 Seconds.
3. Place it on proper position on model.
4. Slide off base paper leaving decals On Model With Wet Finger Tip.
5. Move Decals To Exact Position, Push Out Excess Water Under Decal With Soft Cotton Cloth.
6. When Decals Get Dry Then Complete.

水貼紙使用說明:

1. 將模型表面擦乾淨
2. 將貼紙剪下泡入清水中約15秒
3. 將泡濕之貼紙取出置於欲貼處旁
4. 用指尖輕推貼紙表面使其滑出底紙
5. 將貼紙調整至適當位置並輕擦拭水份
6. 待其自然乾燥後即完成

Color list: 塗料表

Color	Brand	Gunze Sangyo			Humbrol	Revell	Lifecolor
		Hobby Color	Mr.Color	Mr.Color Spray			
Brass	黃銅	H9	C9	J9	54	92	LC75
Flat white	消光白	H11	C62	J62	34	05	LC01
Dark green	深綠	H36	C15	J15	75		UA121
Olive drab(2)	橄欖綠	H78	C38	J38	66	46	UA106
Red	紅	H3	C3	J3	19	31	LC56
Red brown	紅褐	H47	C41	J41	160	383	
Sandy Yellow	沙黃	H66	C119		168		UA020
Steel	黑鐵	H18	C28	J28	53	91	LC76
Tire black	輪胎黑	H77	C33+C62		85	302	LC02
Wood brown	木棕	H37	C43		169		FS12

Variants of Infantry Tank "Churchill"

Shin.ueda
上田 信

3 inch gun carrier Mk.I

It was built to defend mainland United Kingdom against invasion of Nazi Germany.

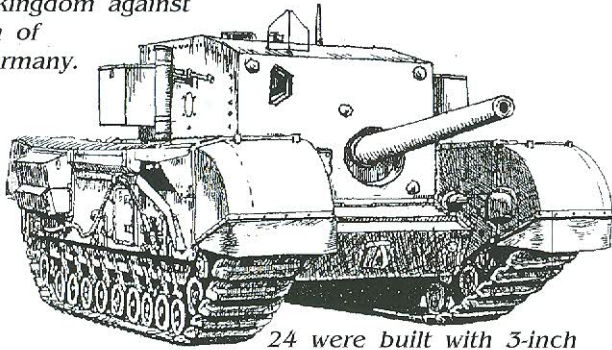

24 were built with 3-inch anti-aircraft gun Mk.III.

Churchill Mk.IV(NA)

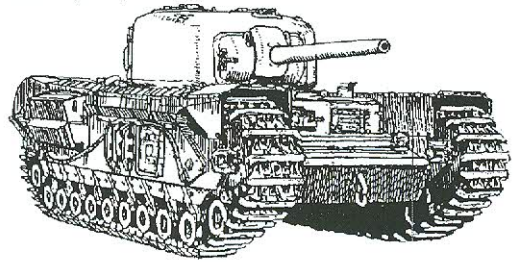

Retrofitted with 75 mm tank gun of M4 Sherman tank to provide better fire power. 120 were modified in maintenance facilities located in North Africa. Used in Italian Campaign.

Churchill AVRE

Armored vehicle used by the Corps of Royal Engineers.

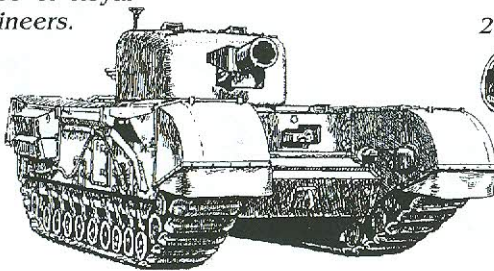

290 mm Petard Mortar

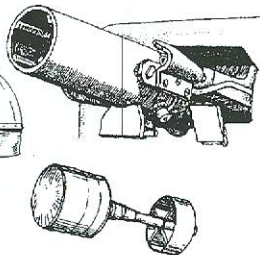

18 kg mortar rounds was used to demolish structures.

Bridge Layer Tank

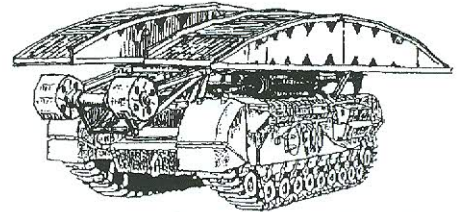

Mounted with 30 ft Tank Bridge No.2.

"ARK" Armored Ramp Carrier

"ARK" Ramp Carrier Usage Examples

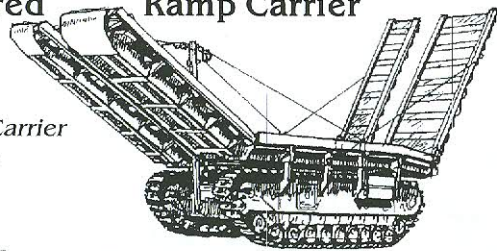
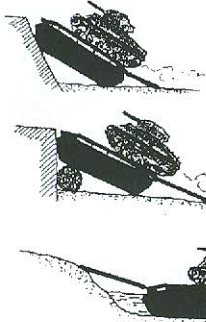

"Fascine"

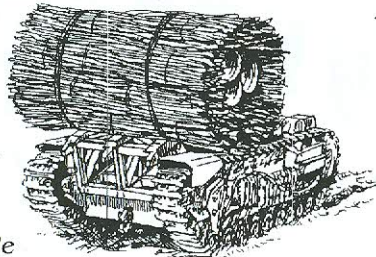

A bundle of wooden poles or rough brushwood tied together with wires was released to fill a ditch or form a step.

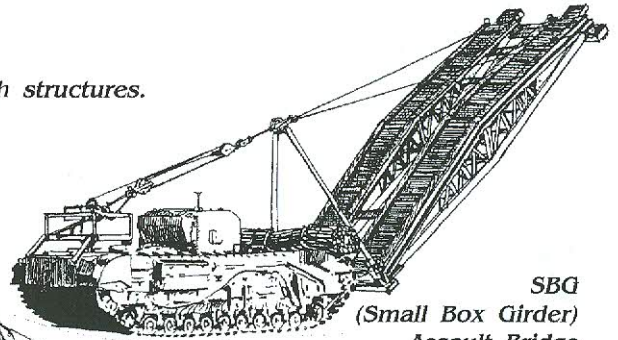

SBG (Small Box Girder) Assault Bridge

"Goat" Demolition Charge Layer

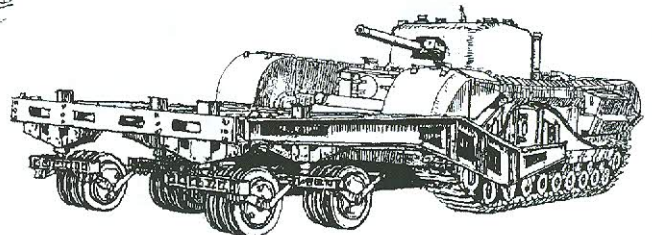
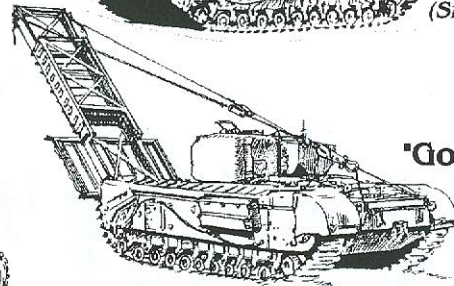

AMRCR Mine-clearing Roller

"Bobbin" Mk.II Carpet Layer

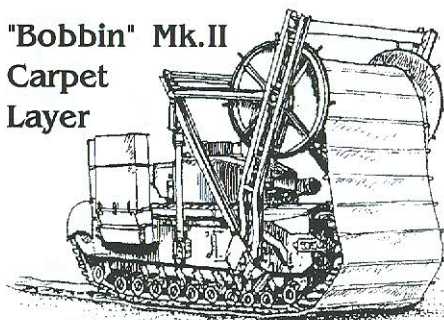

Canvas carpet was laid on soft ground to create a path for vehicles.

Log Carpet Layer (Wooden Pole Carpet)

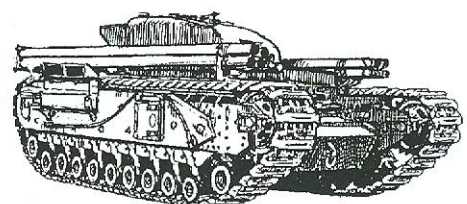
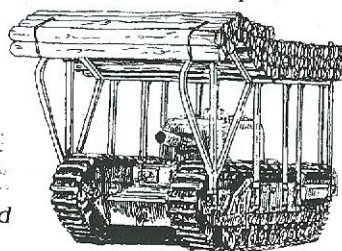

"Snake" Mine-clearing Line Charge Device Carrier

1

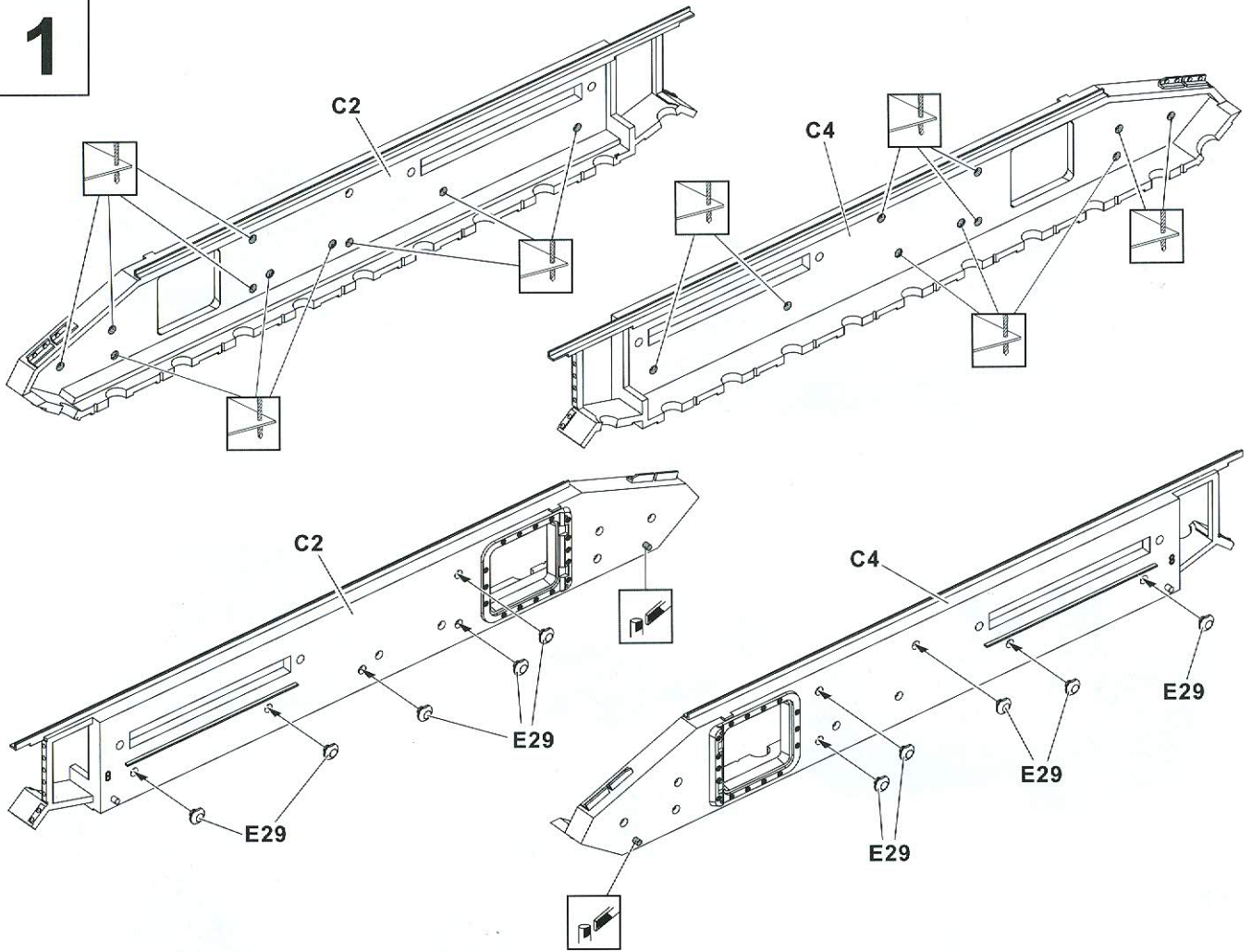

2

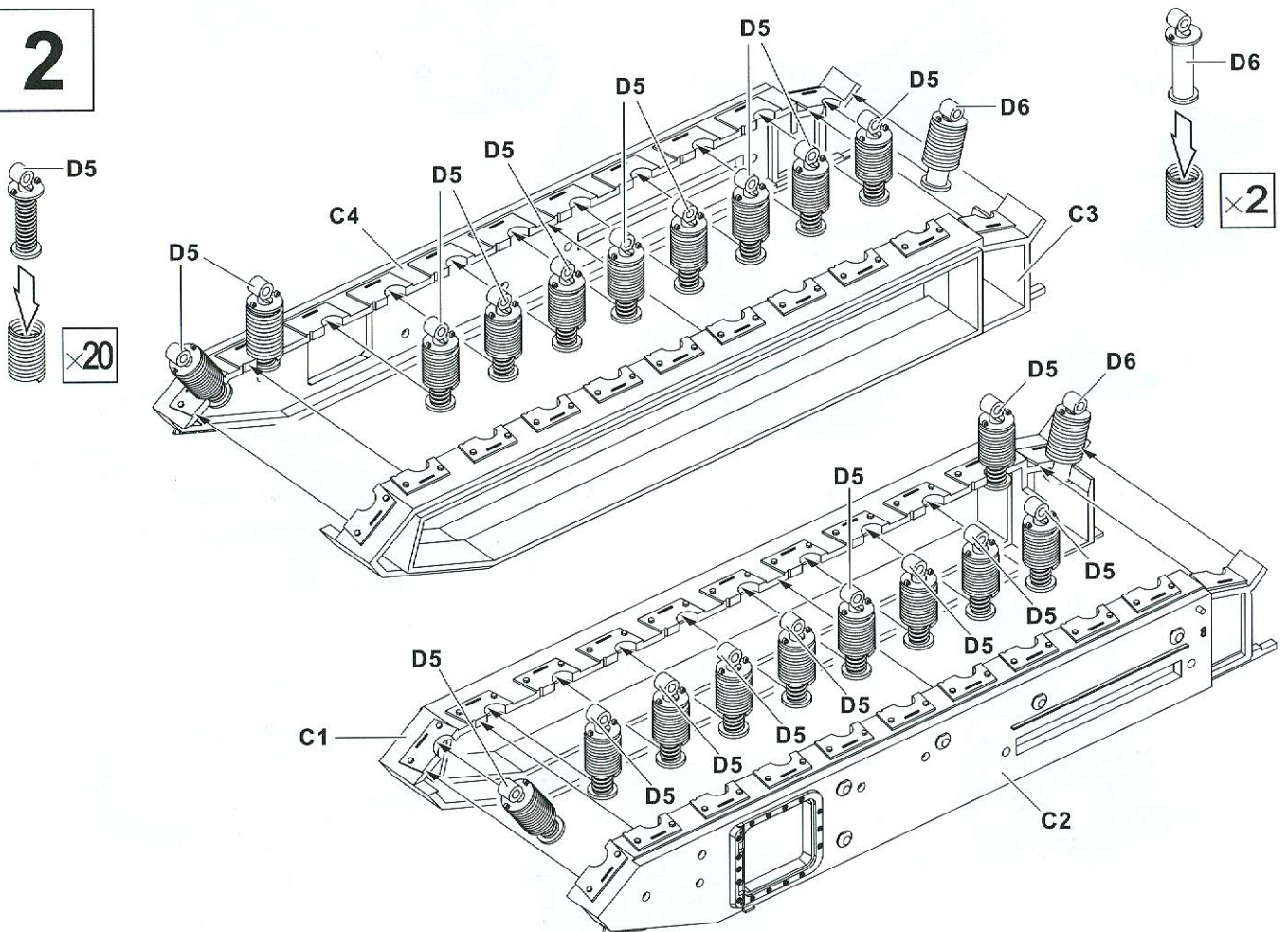

3

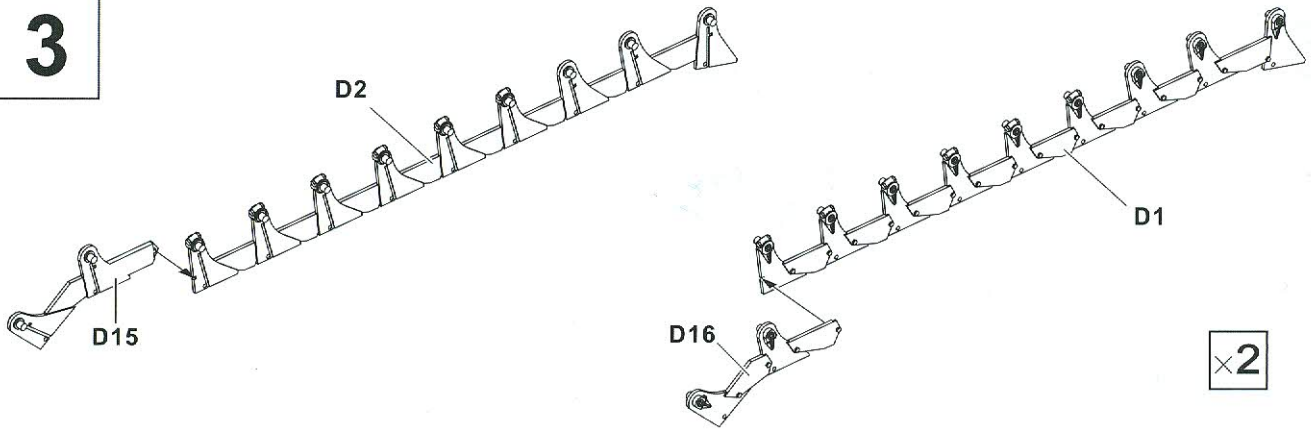

4

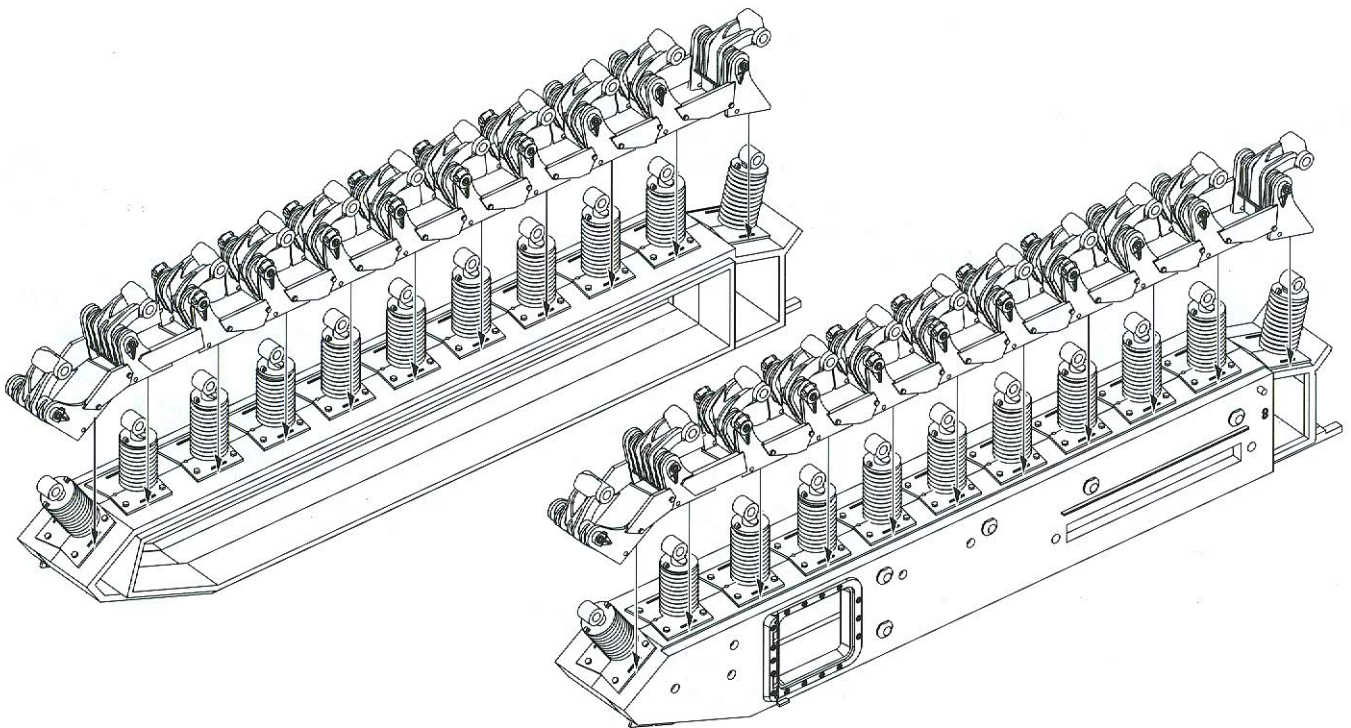
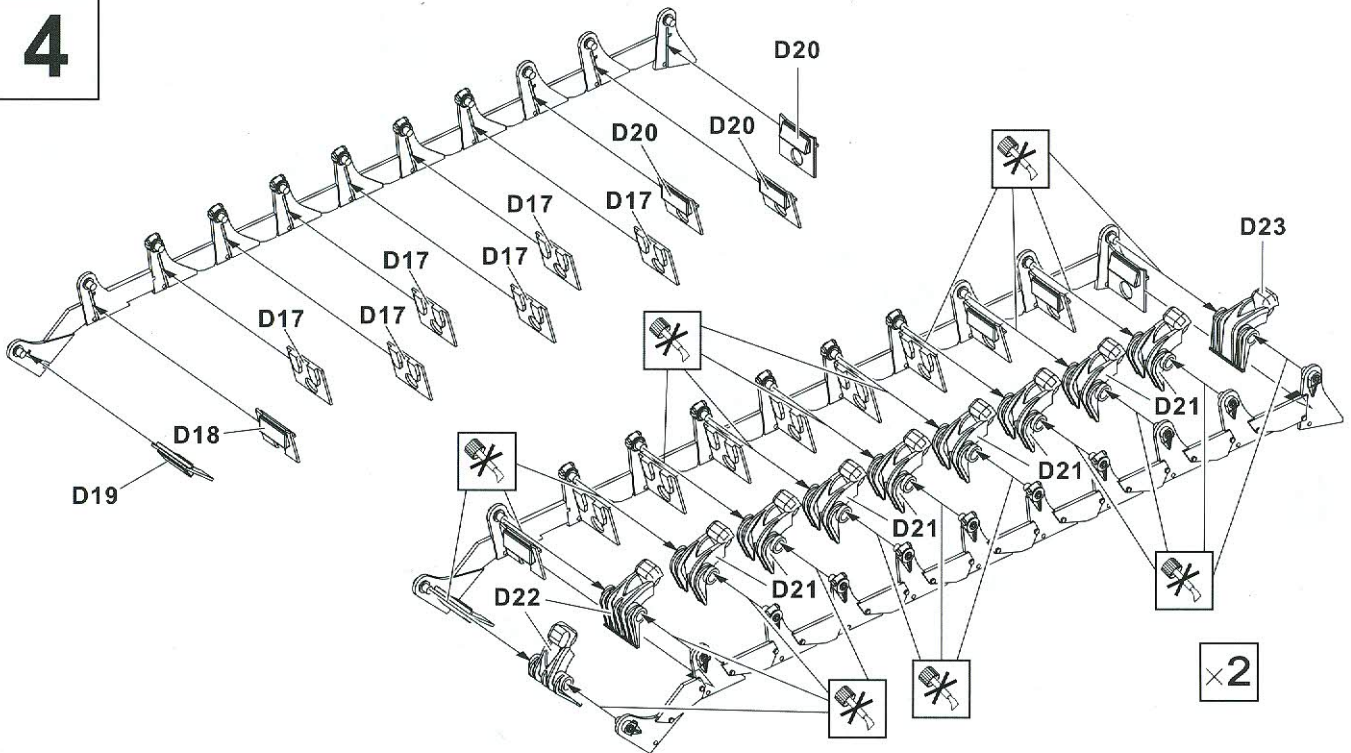

5

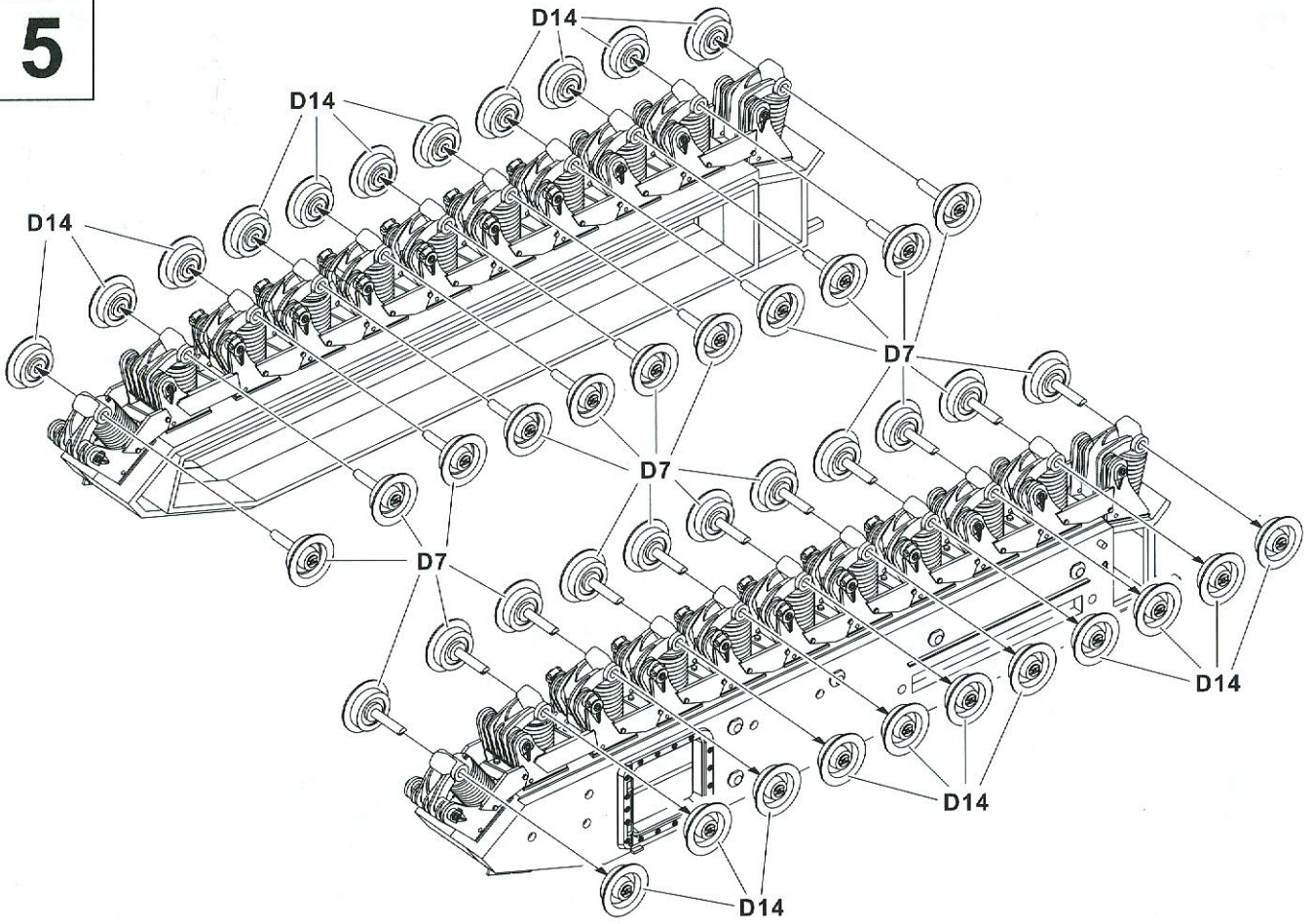

6

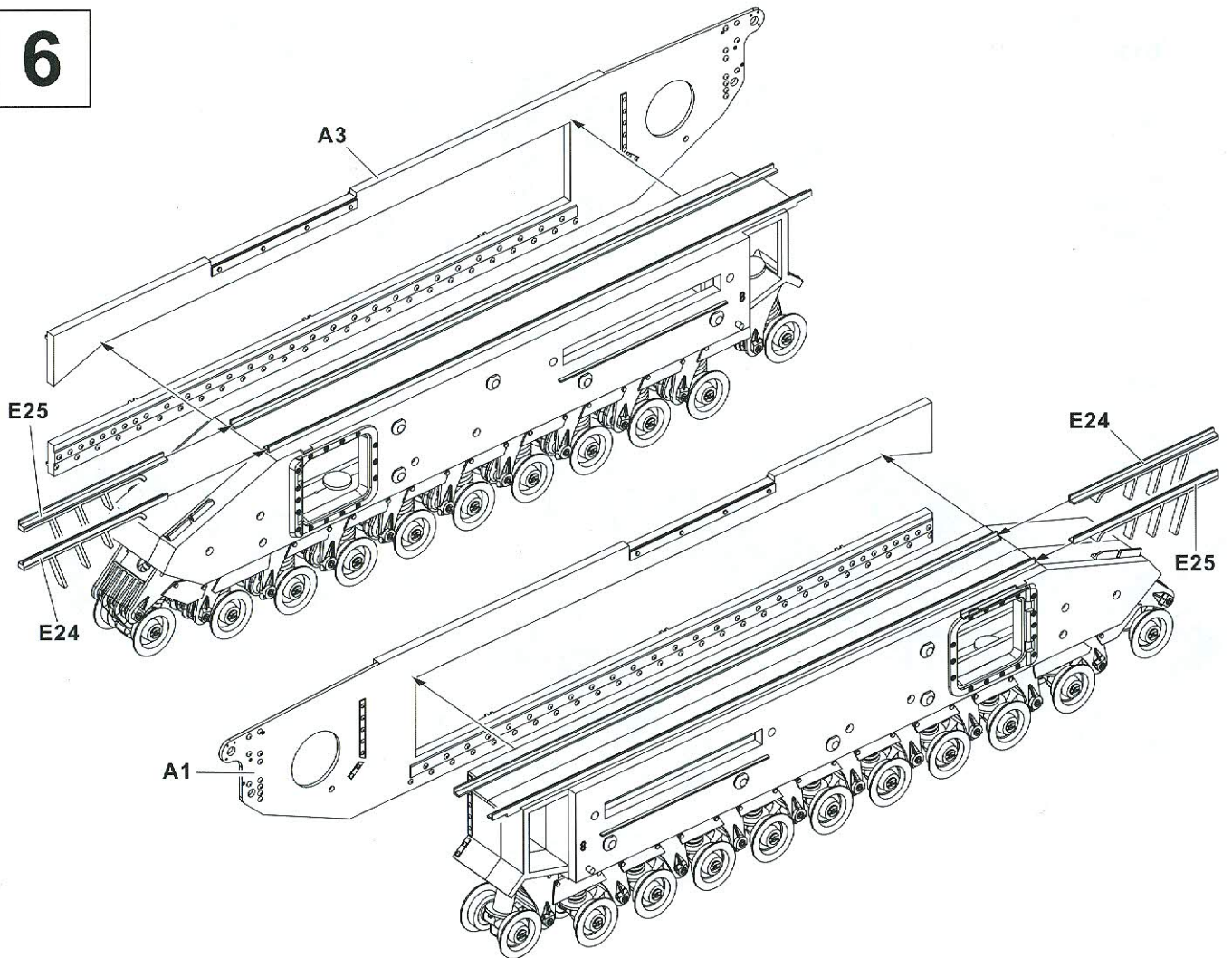

7

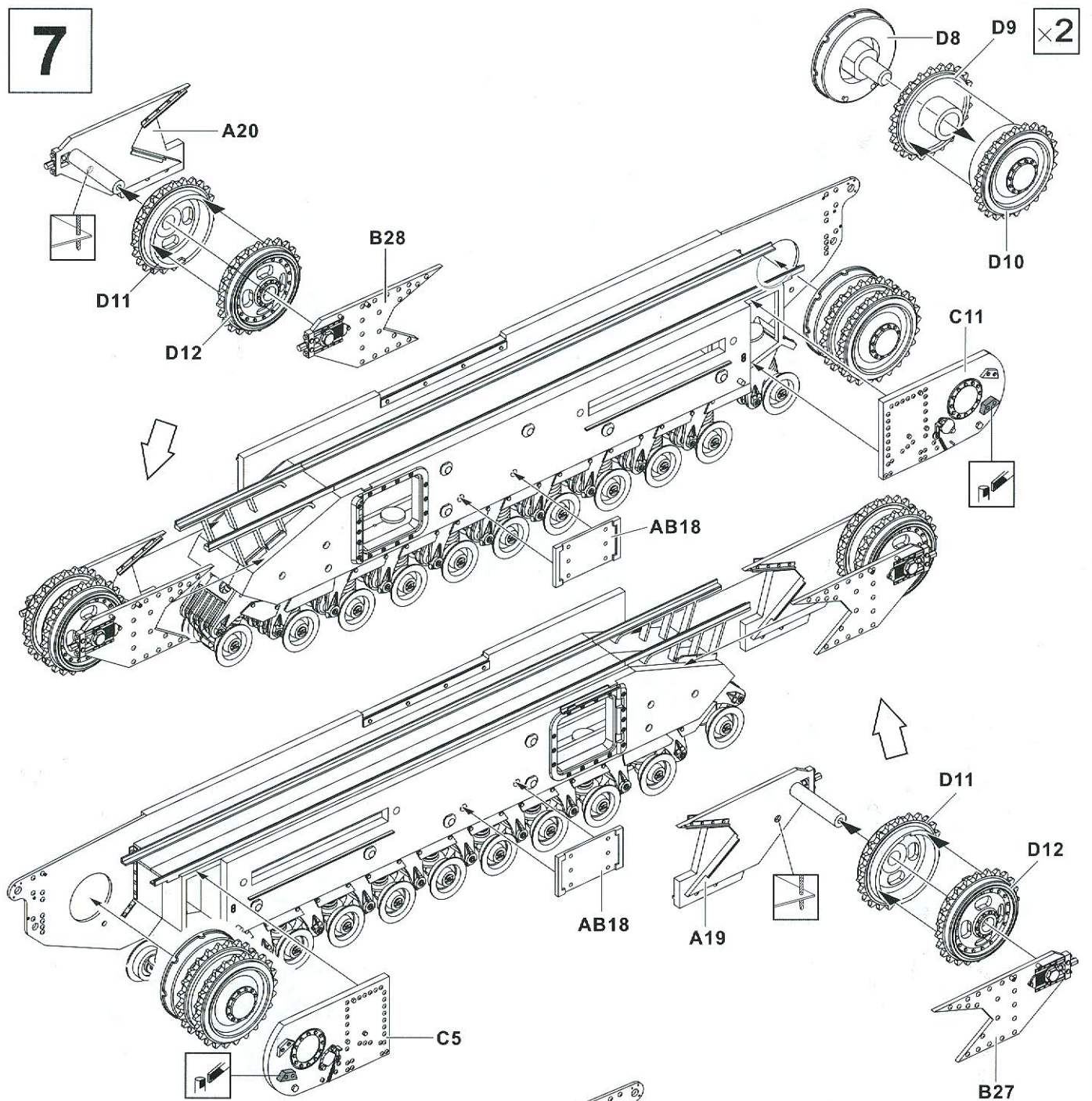

8

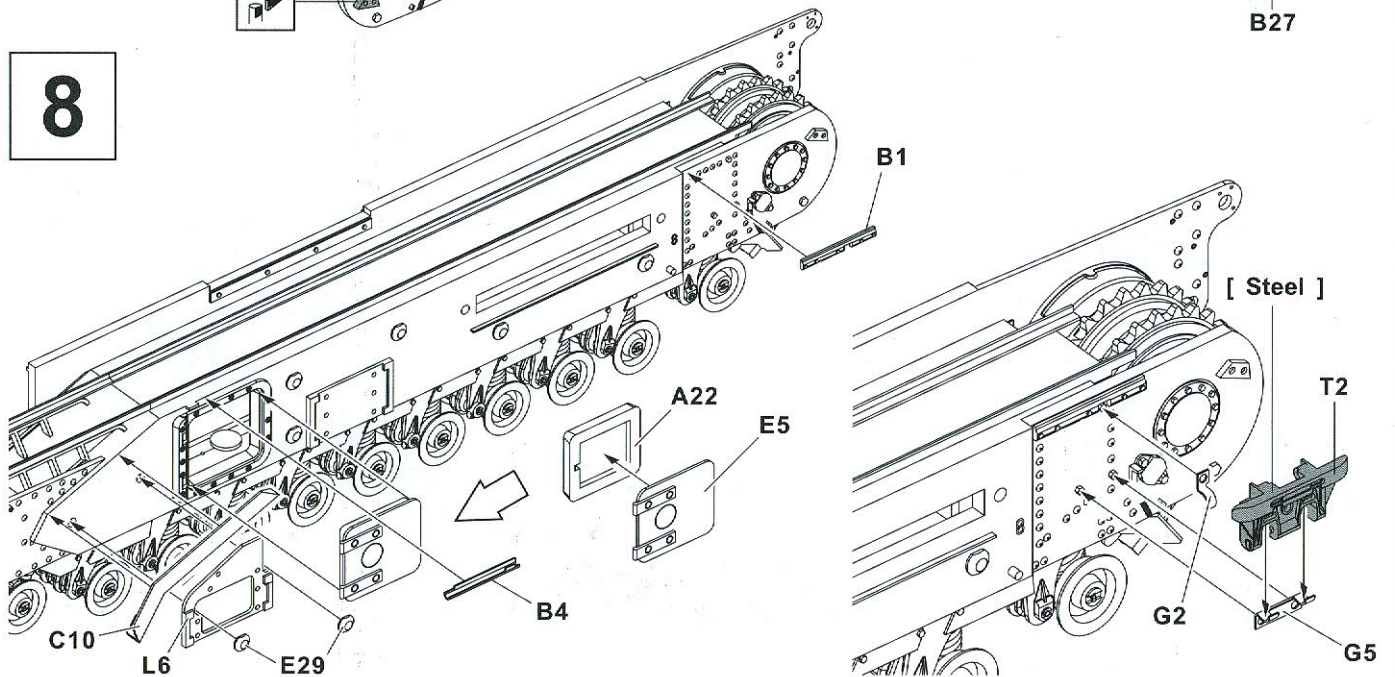

9

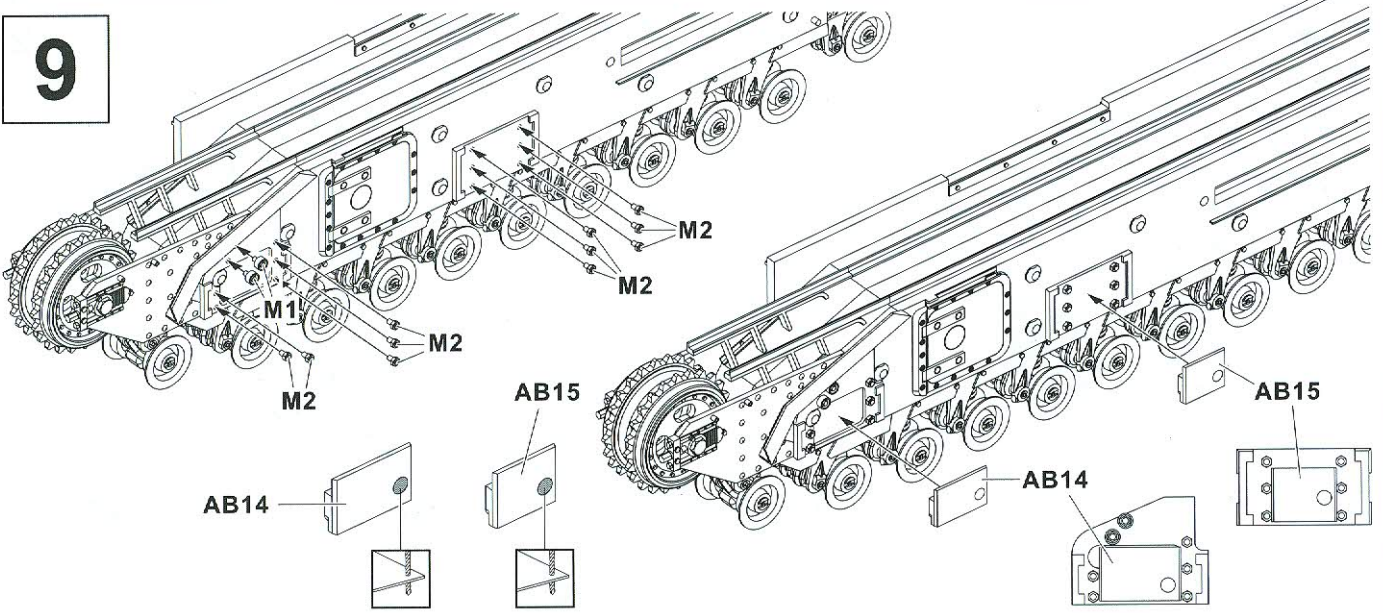

10

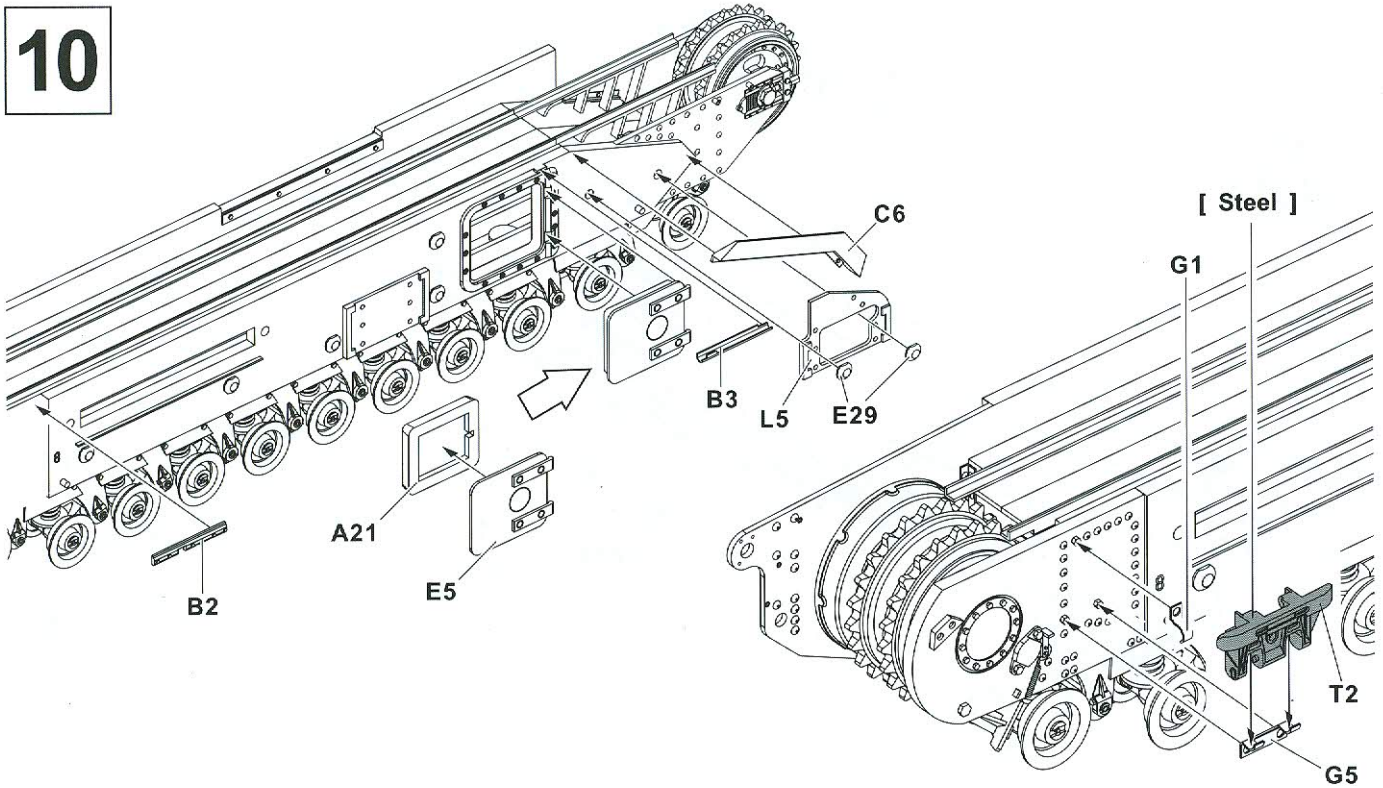

11

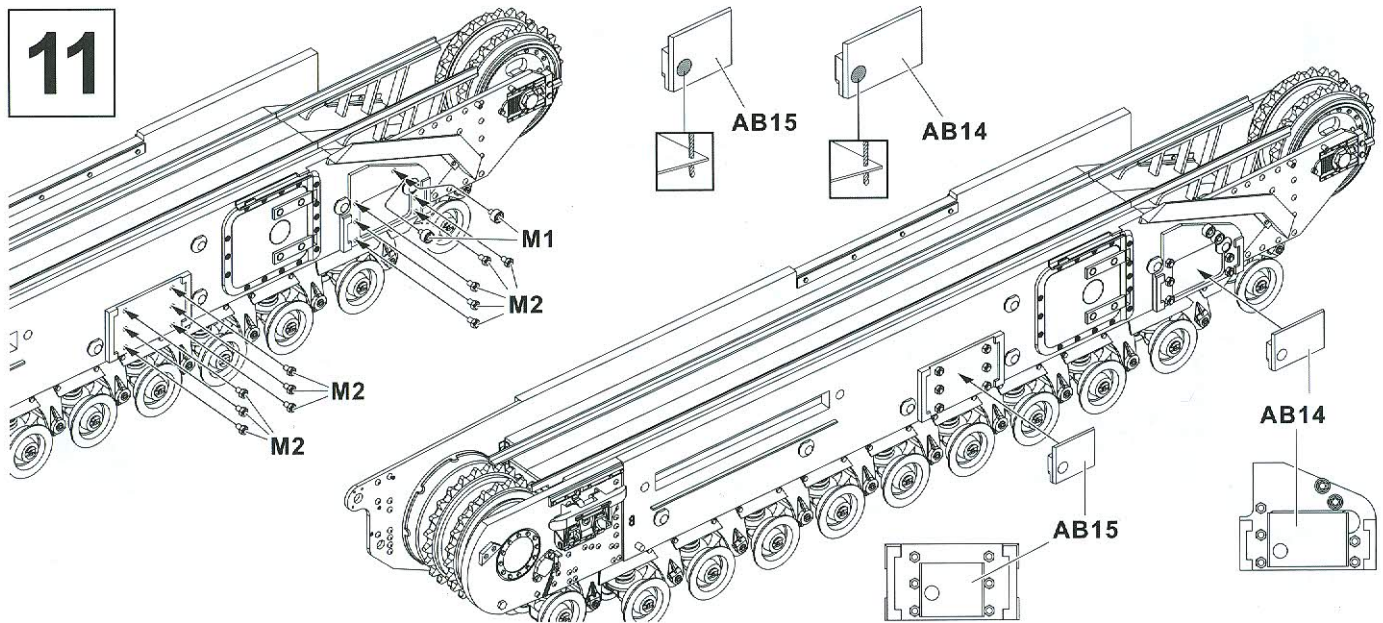

12

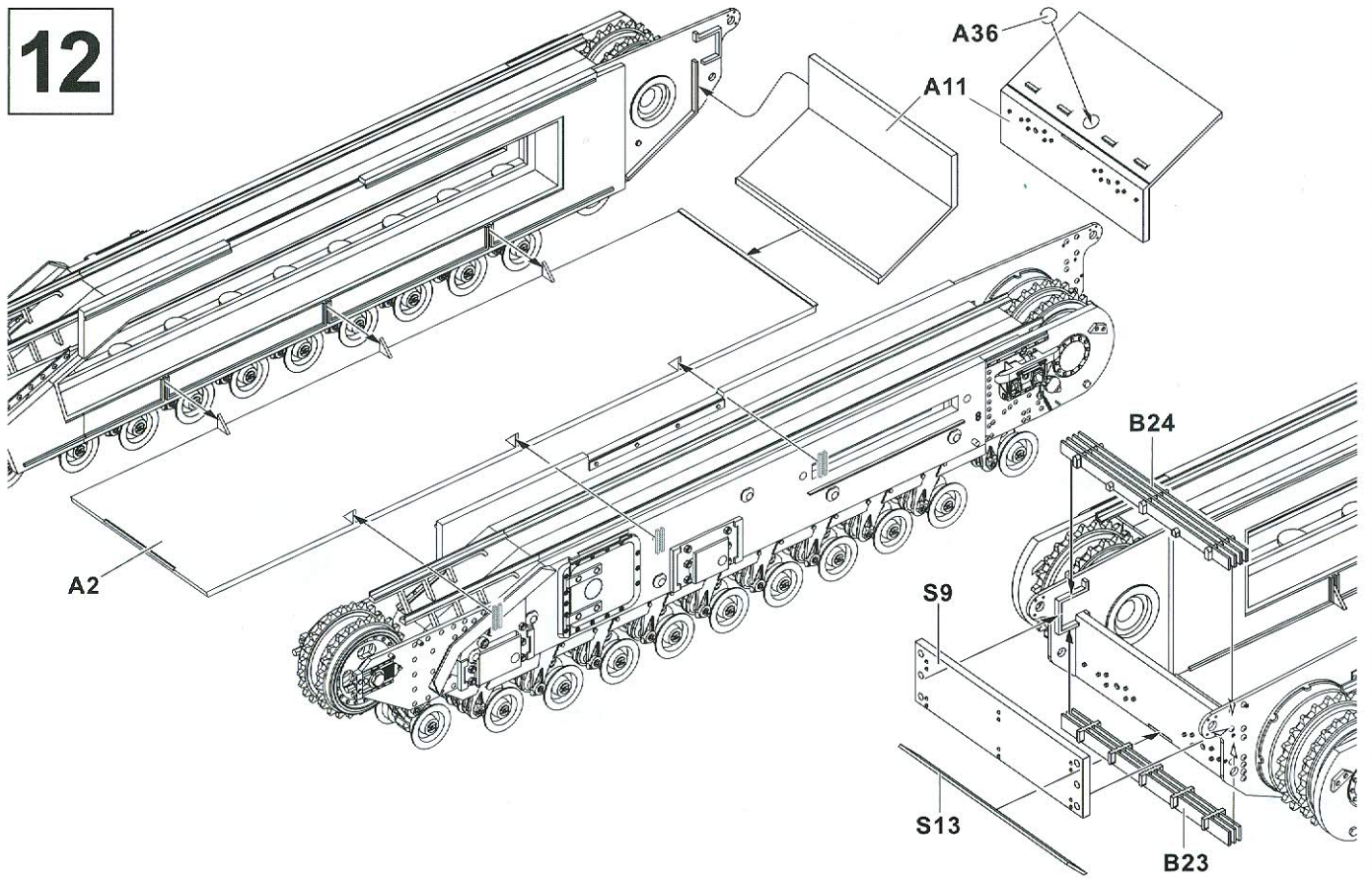

13

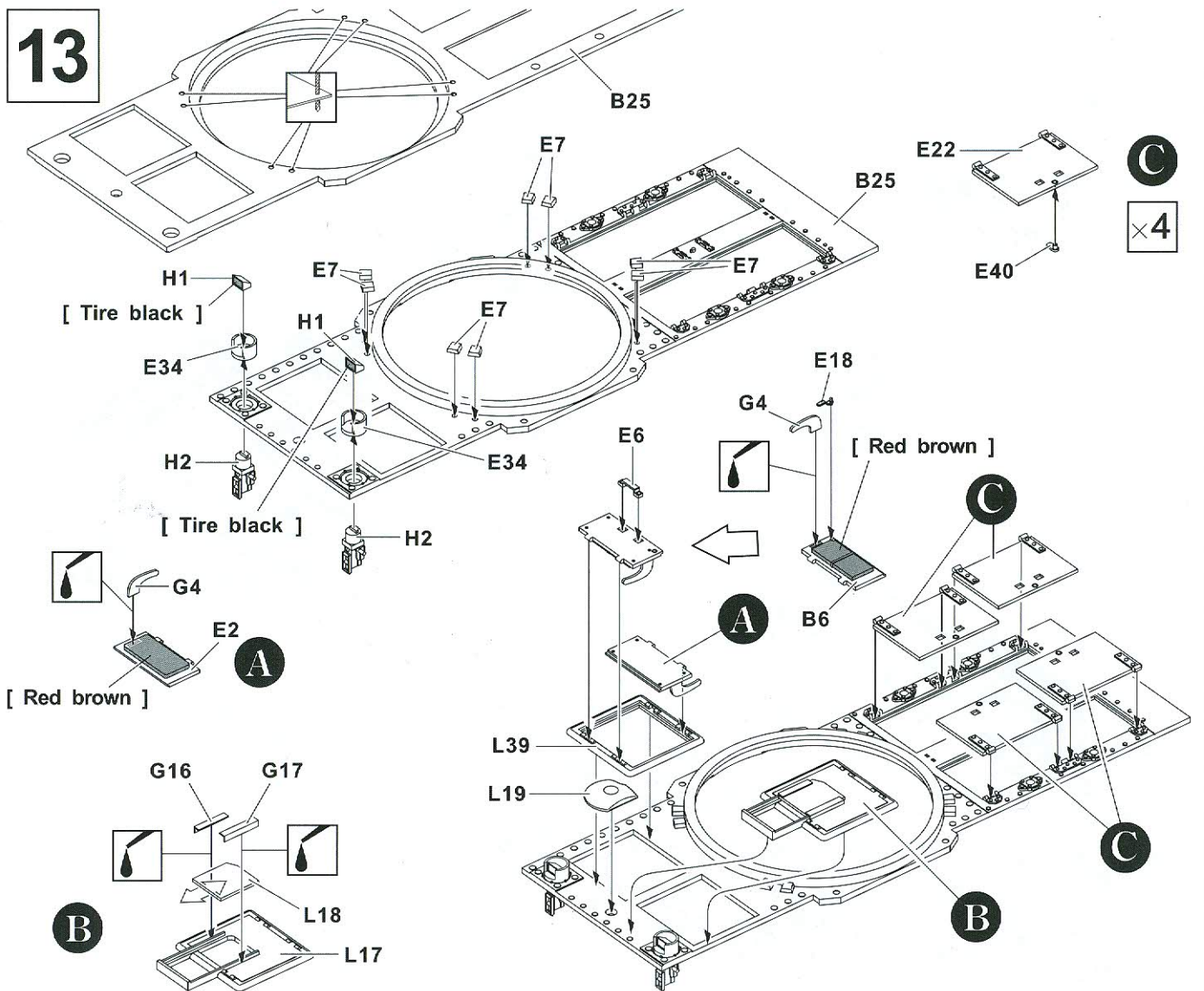

14



15

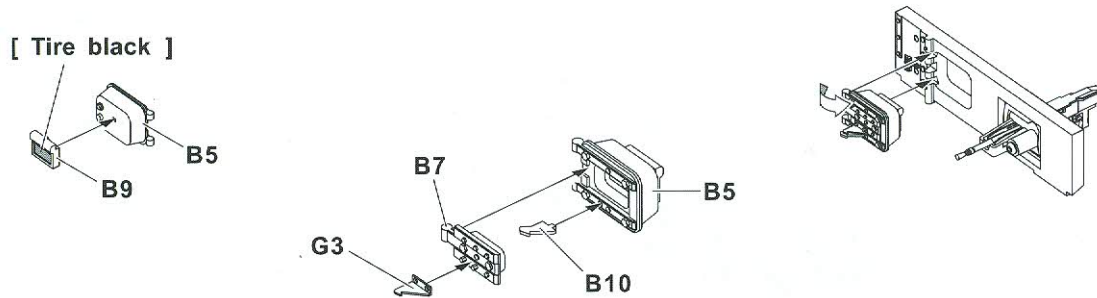

16

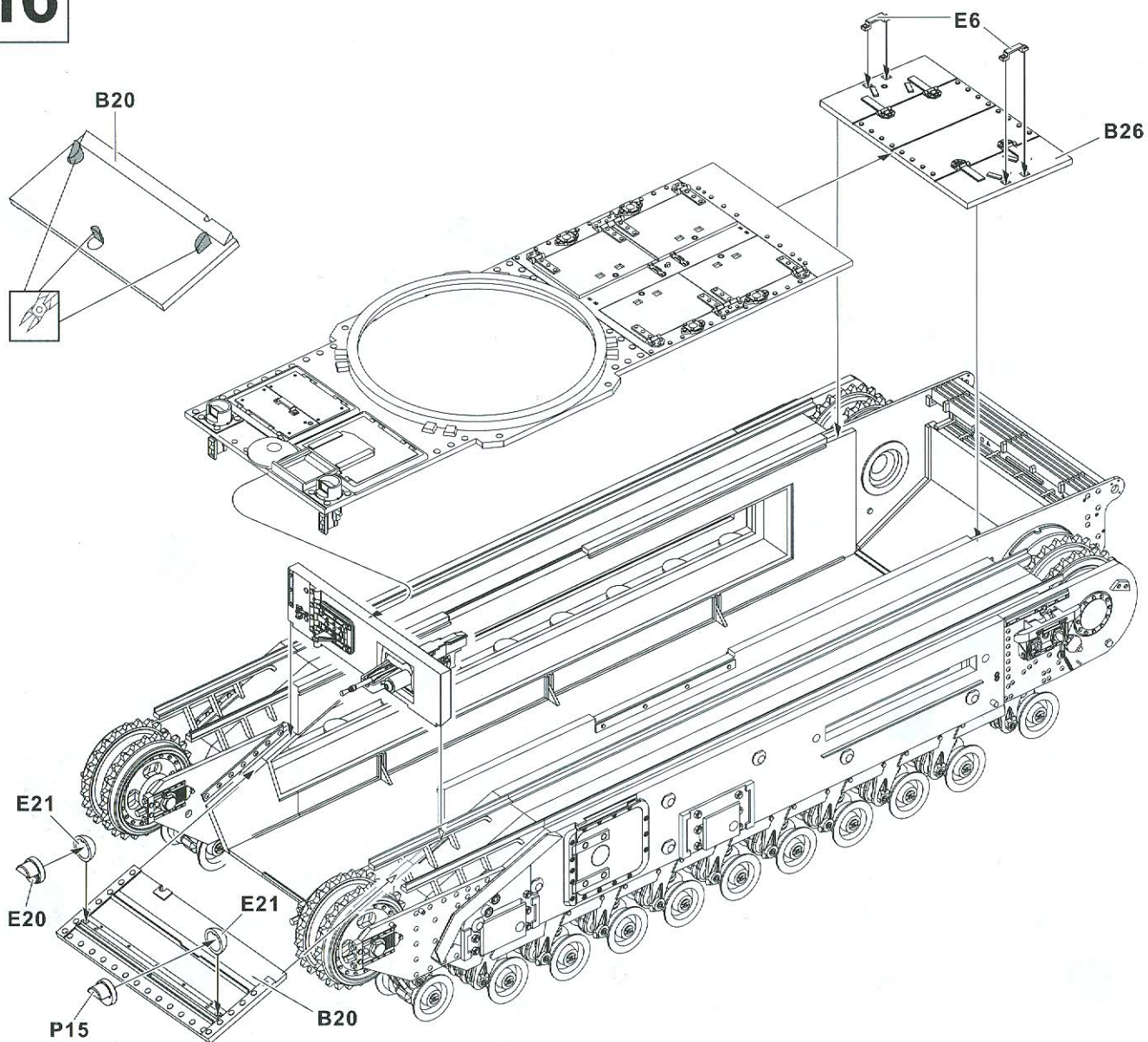

17

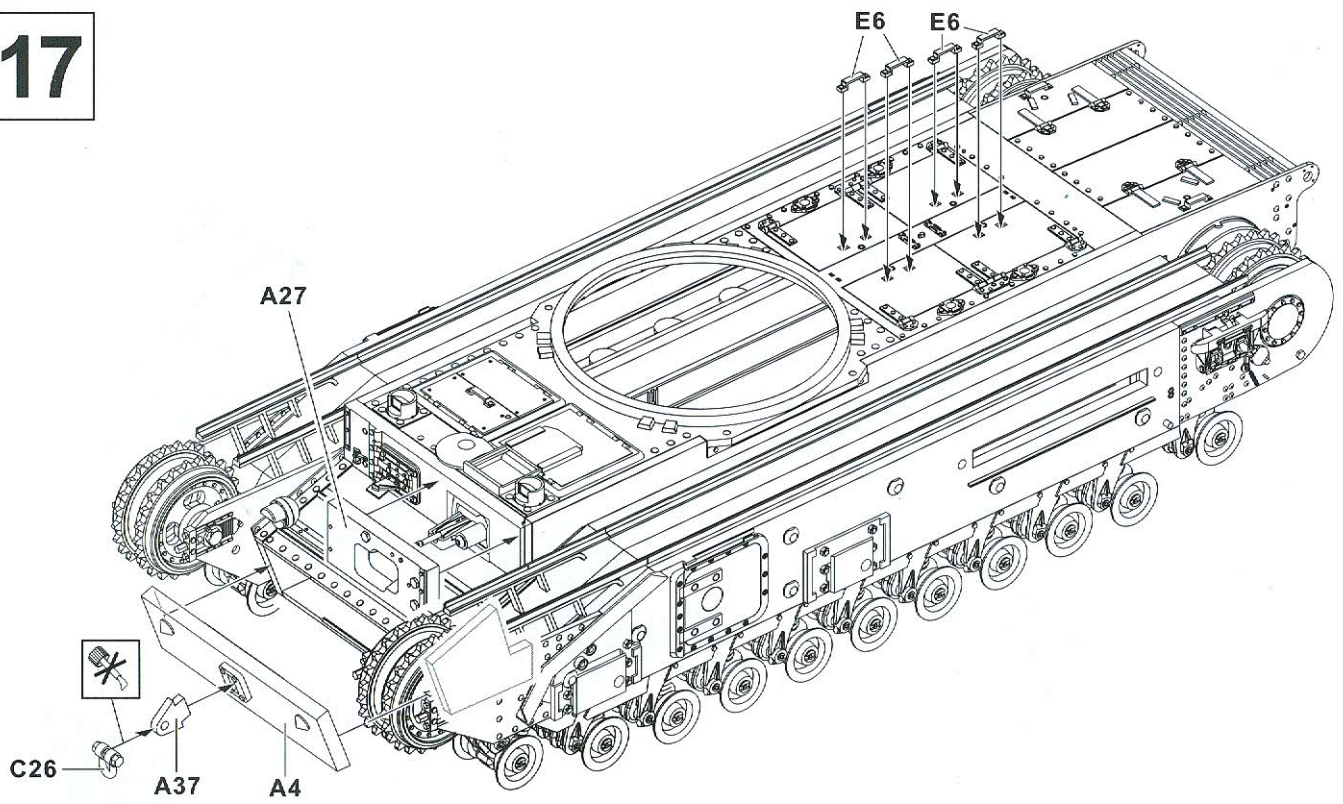

18

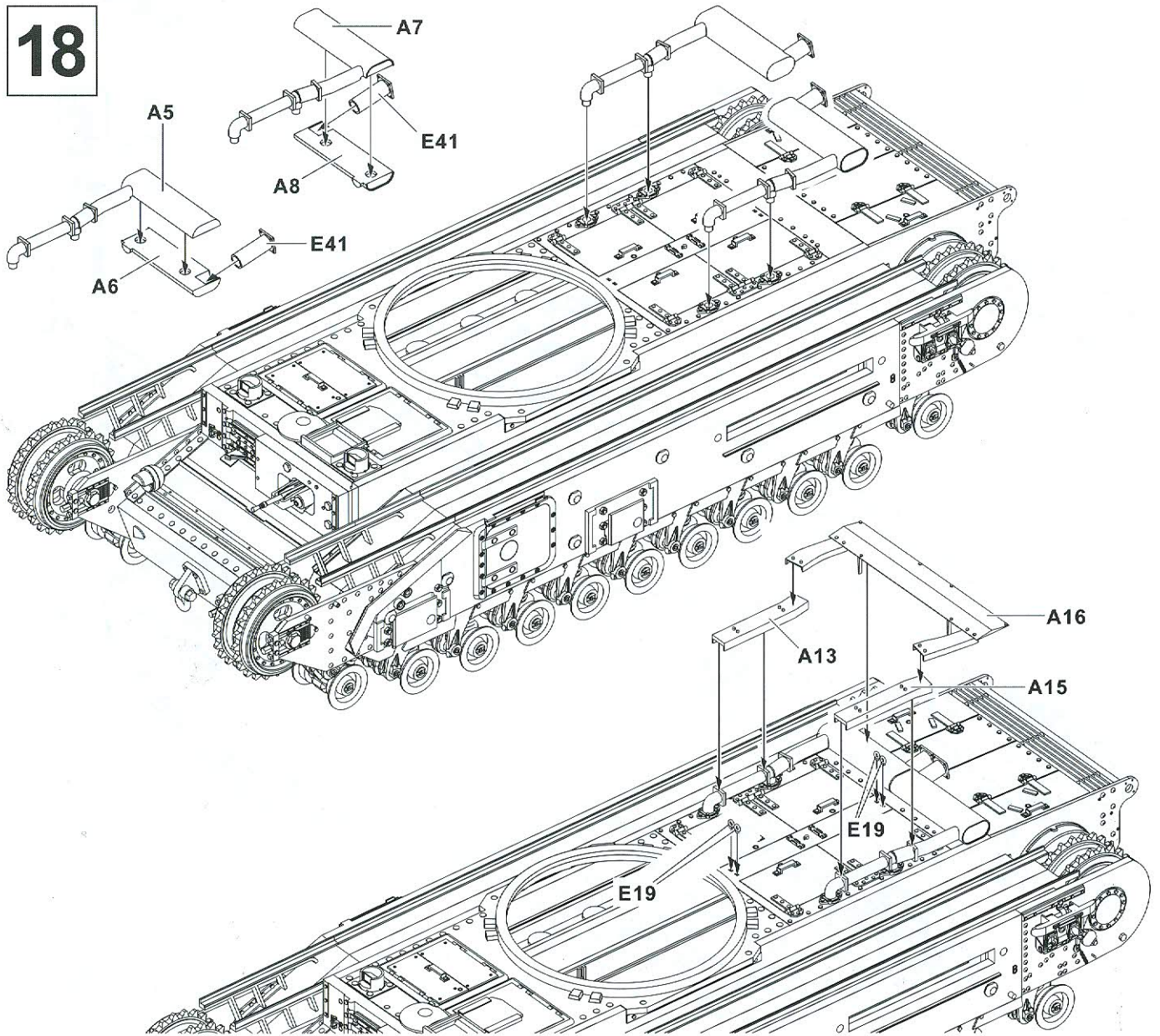

19

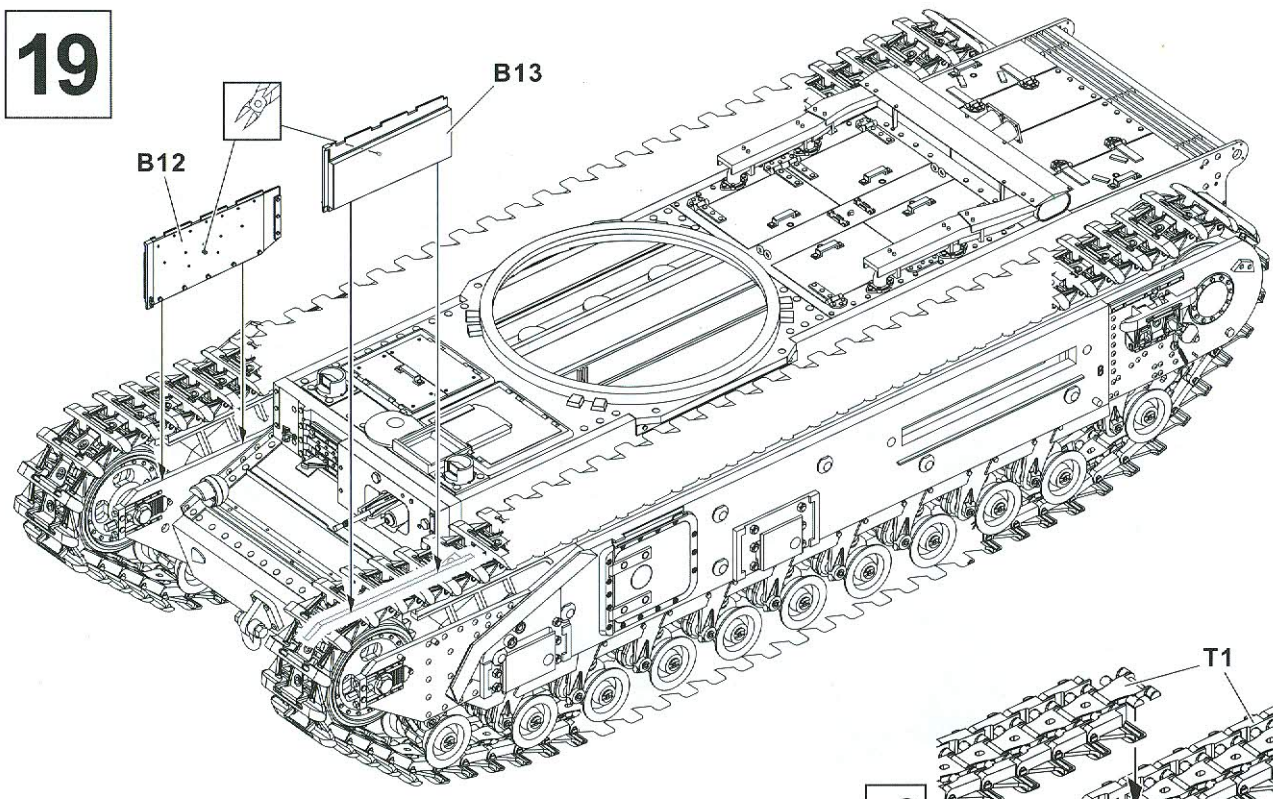

20

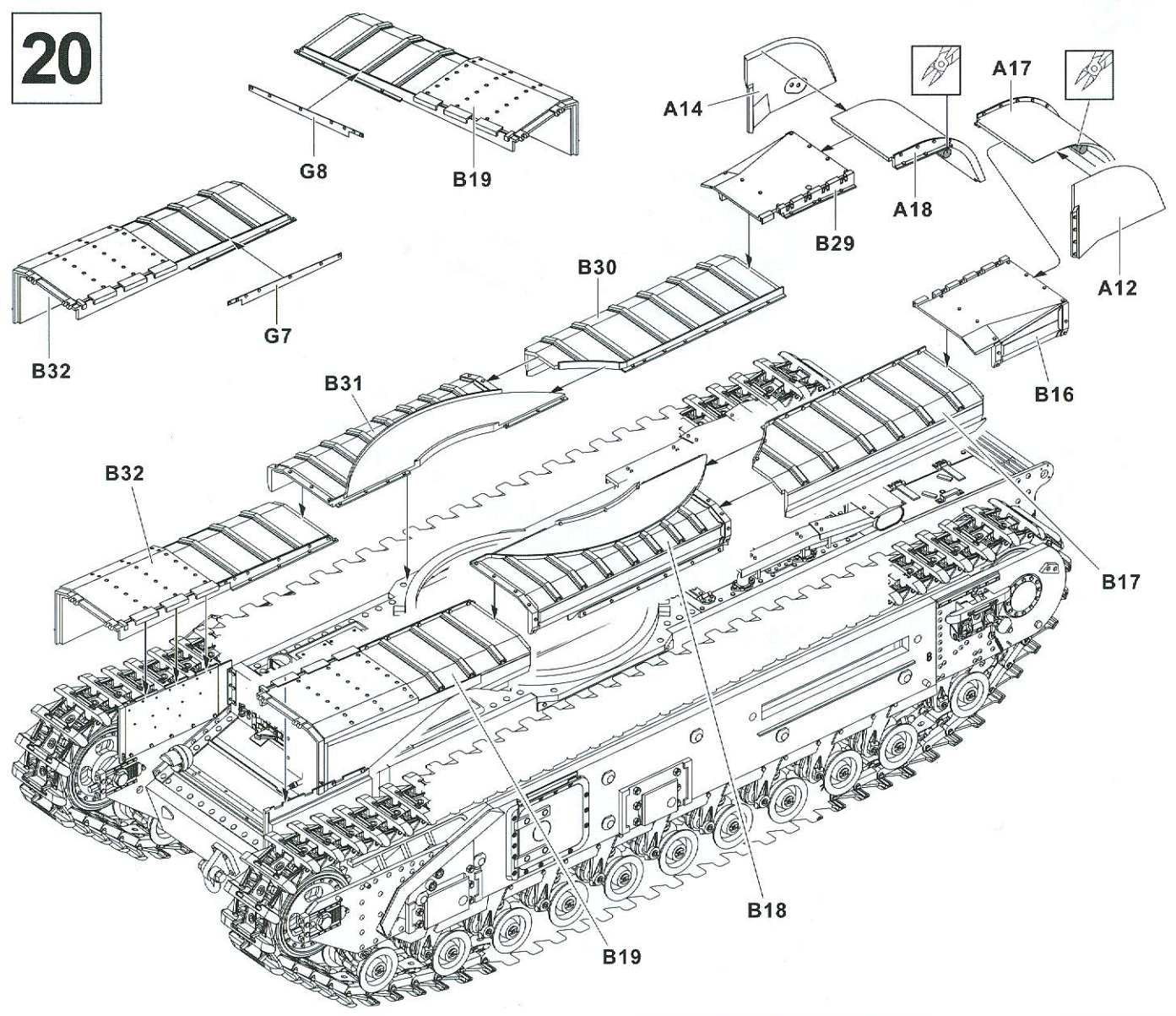

21

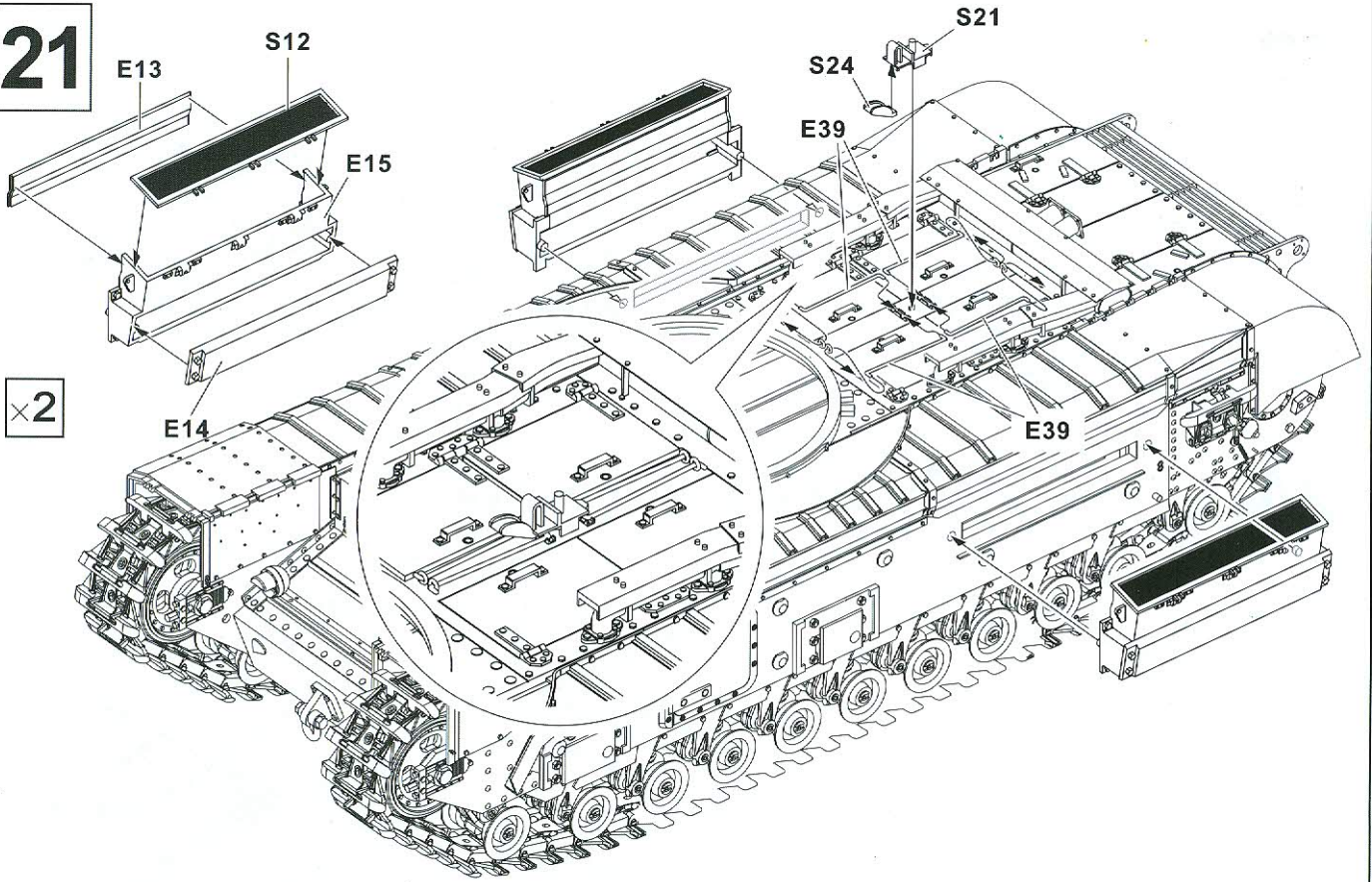

×2

22

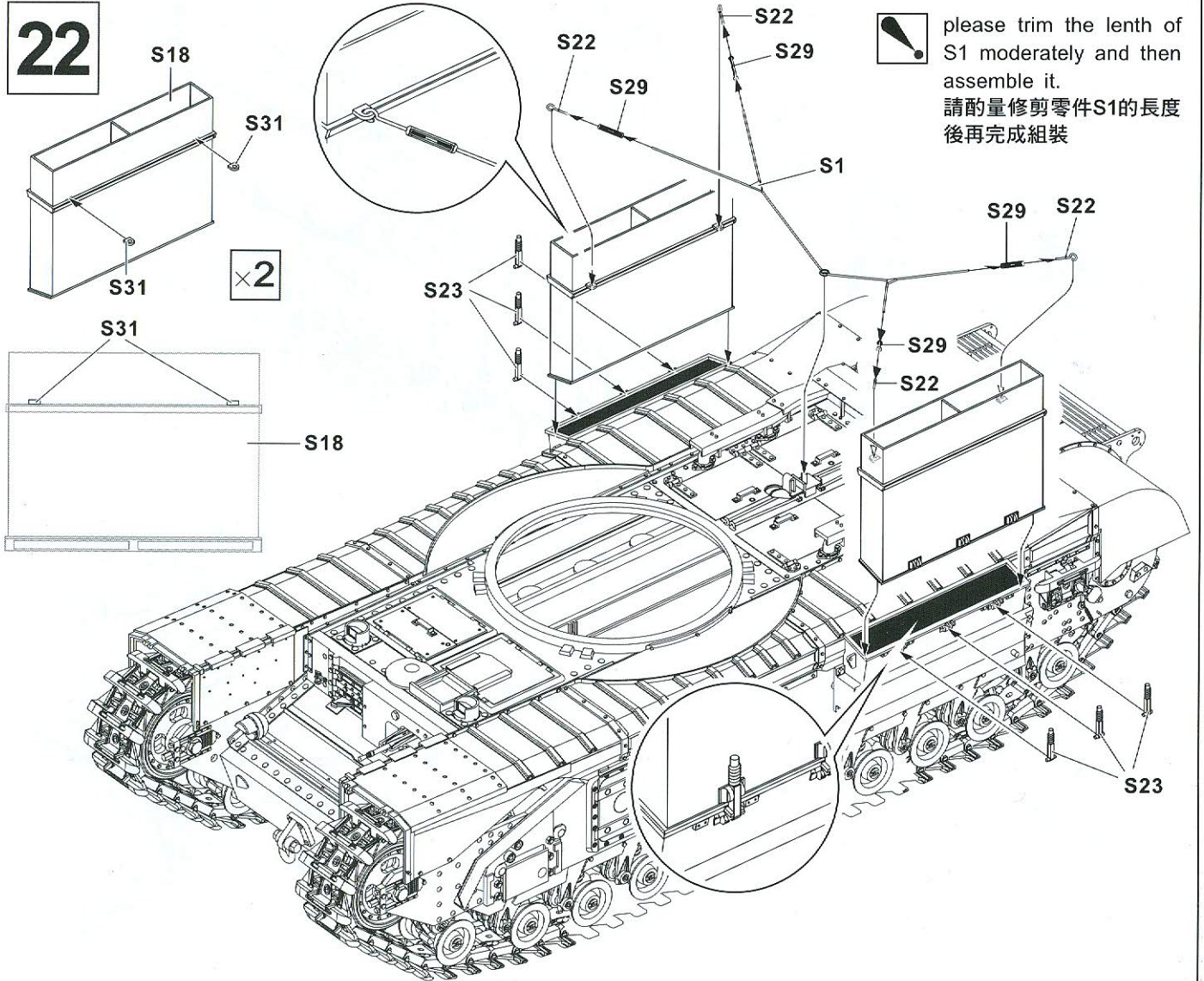

please trim the lenth of S1 moderately and then assemble it.
請酌量修剪零件S1的長度後再完成組裝

×2

23

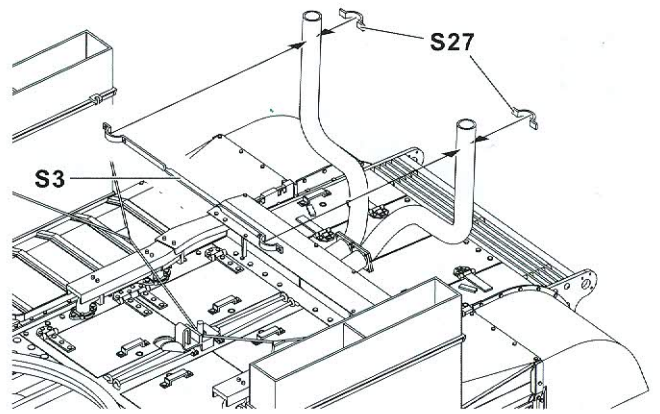
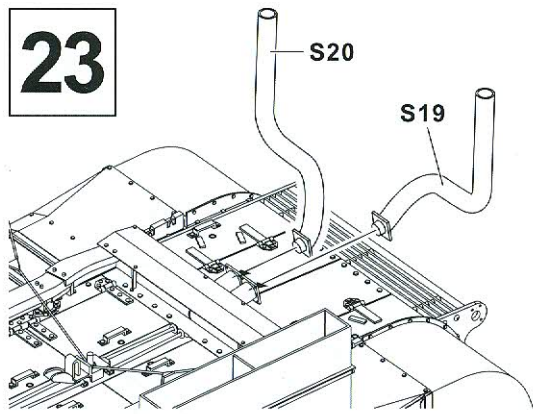

24

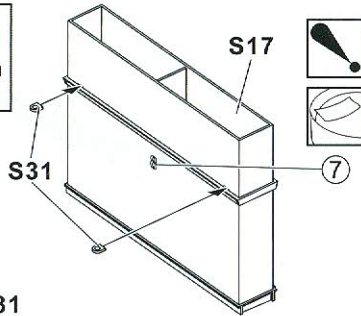

please trim the length of S2 moderately and then assemble it.
請酌量修剪零件S2的長度後再完成組裝

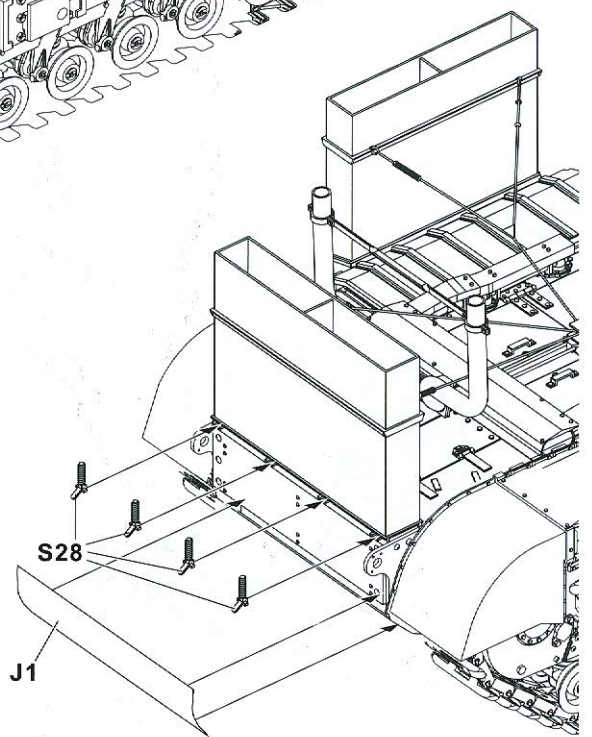
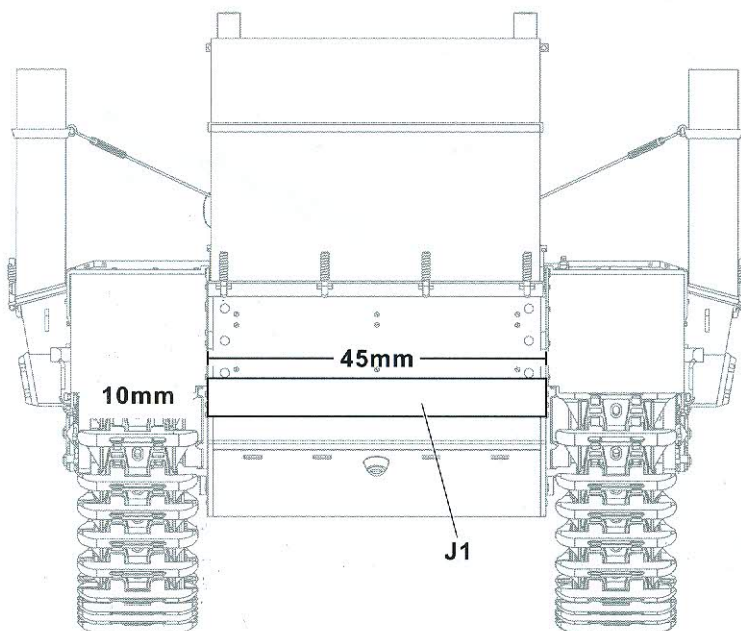
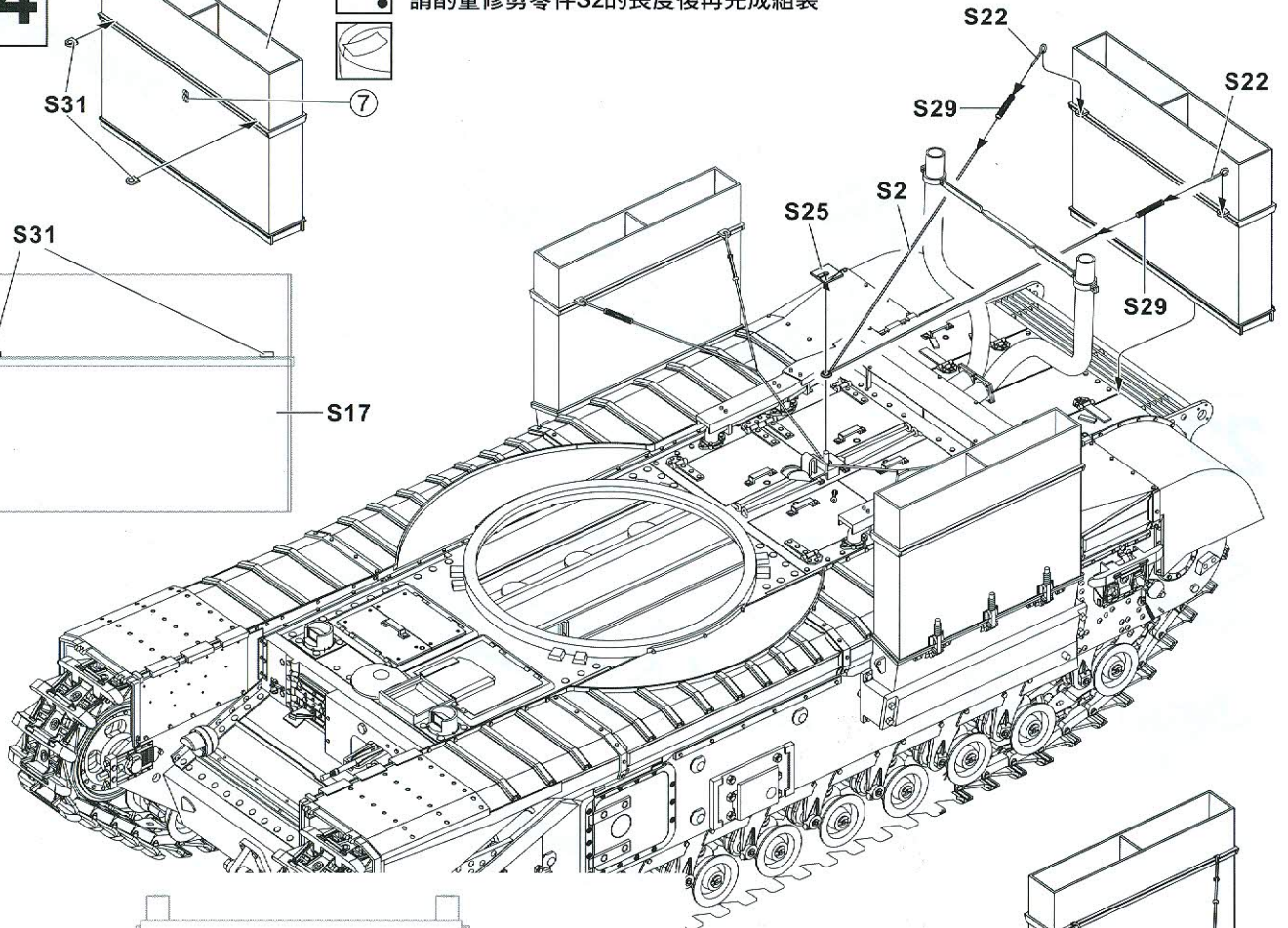
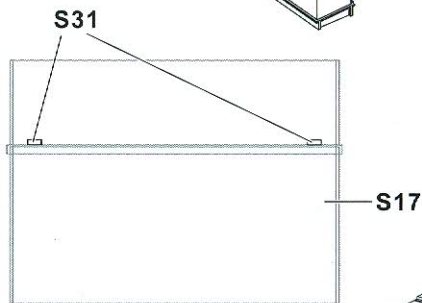

25

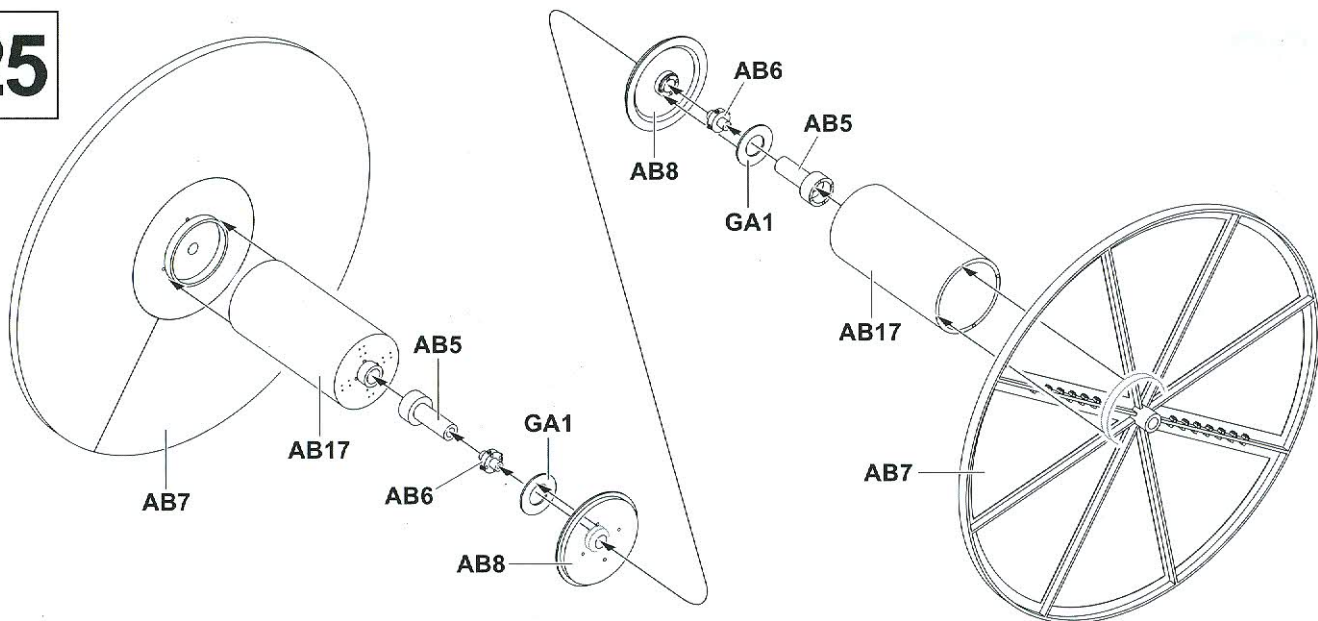

26

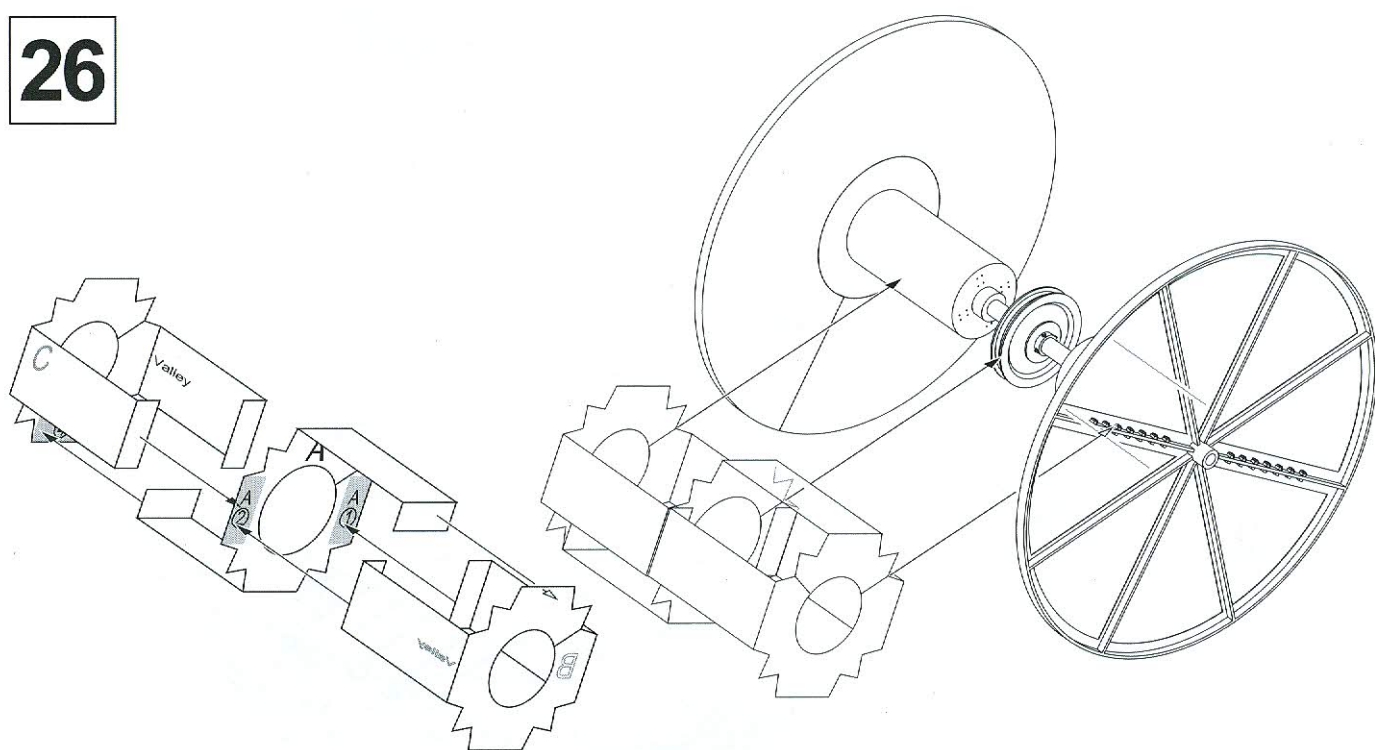

27

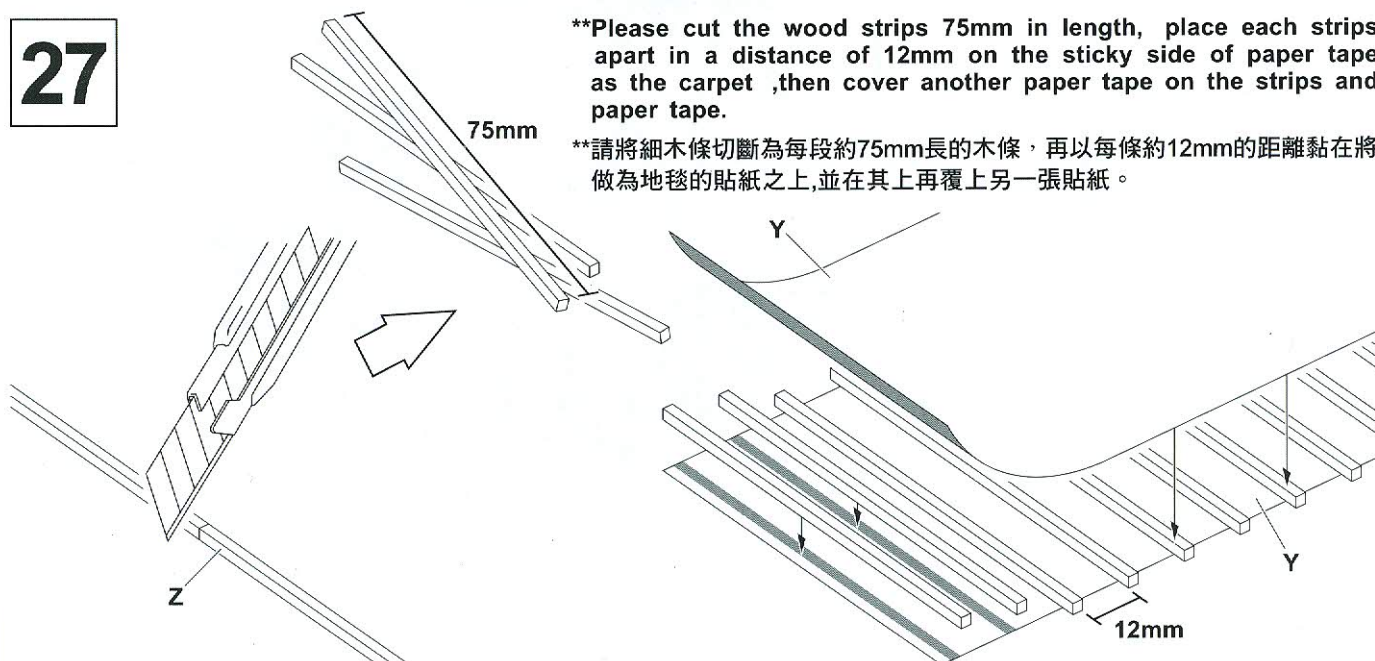

****Please cut the wood strips 75mm in length, place each strips apart in a distance of 12mm on the sticky side of paper tape as the carpet ,then cover another paper tape on the strips and paper tape.**

****請將細木條切斷為每段約75mm長的木條，再以每條約12mm的距離黏在將做為地毯的貼紙之上，並在其上再覆上另一張貼紙。**

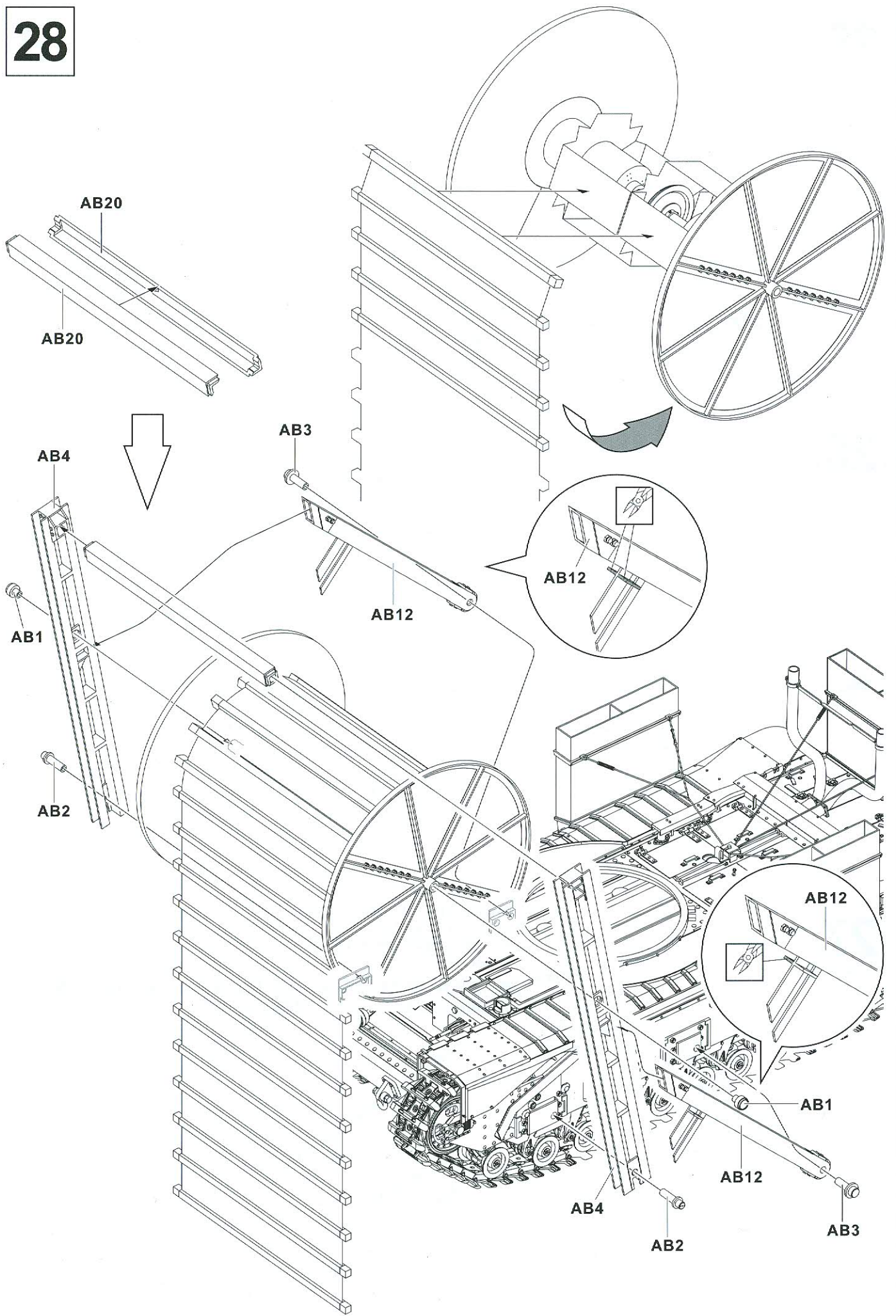

29

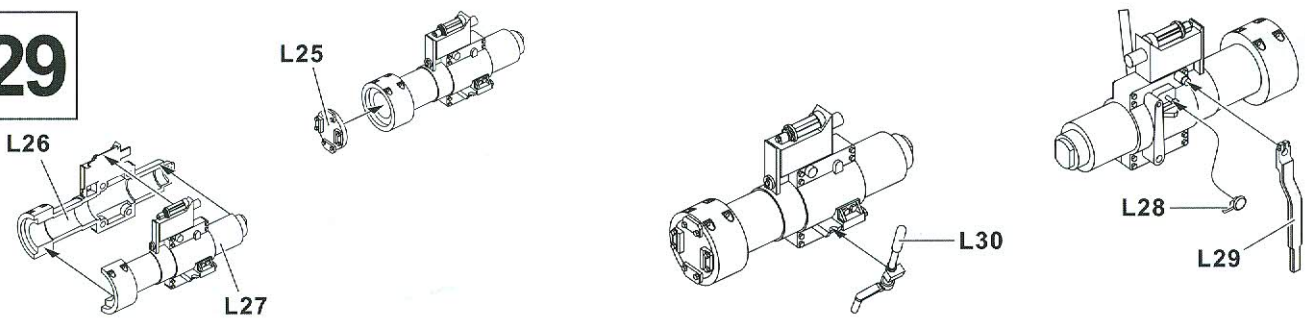

30

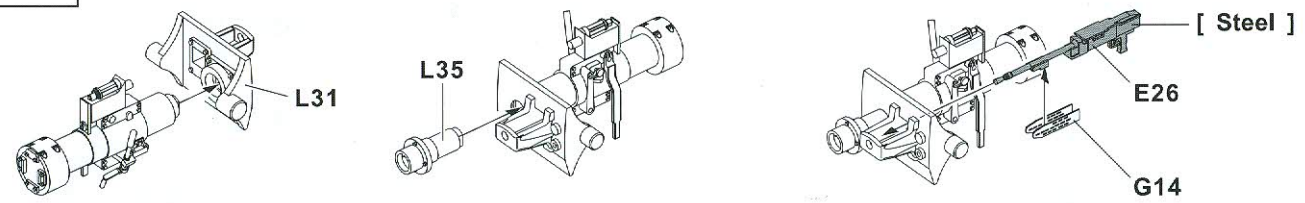

31

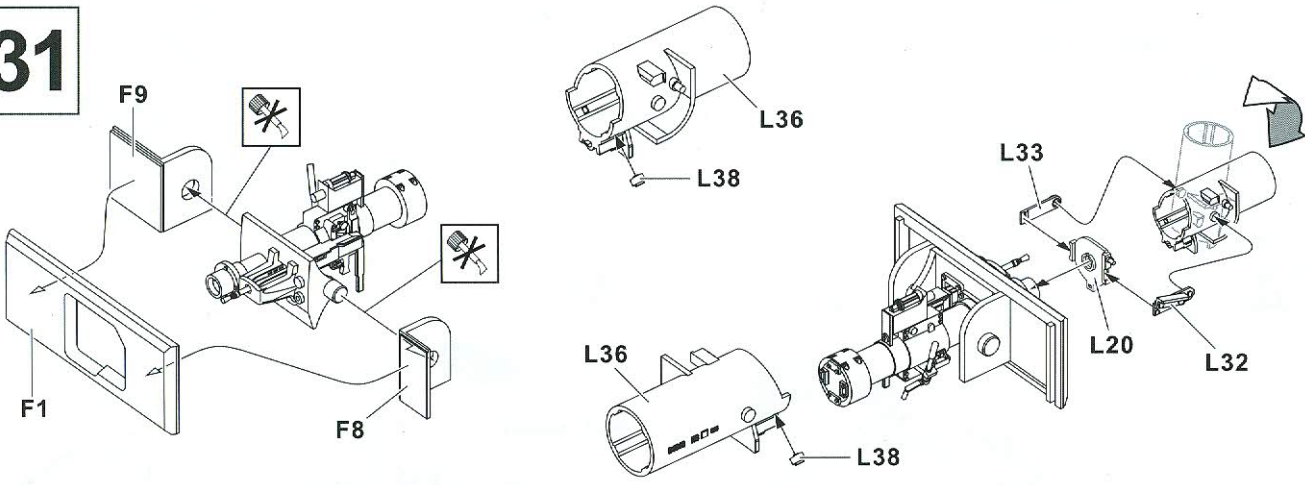

32

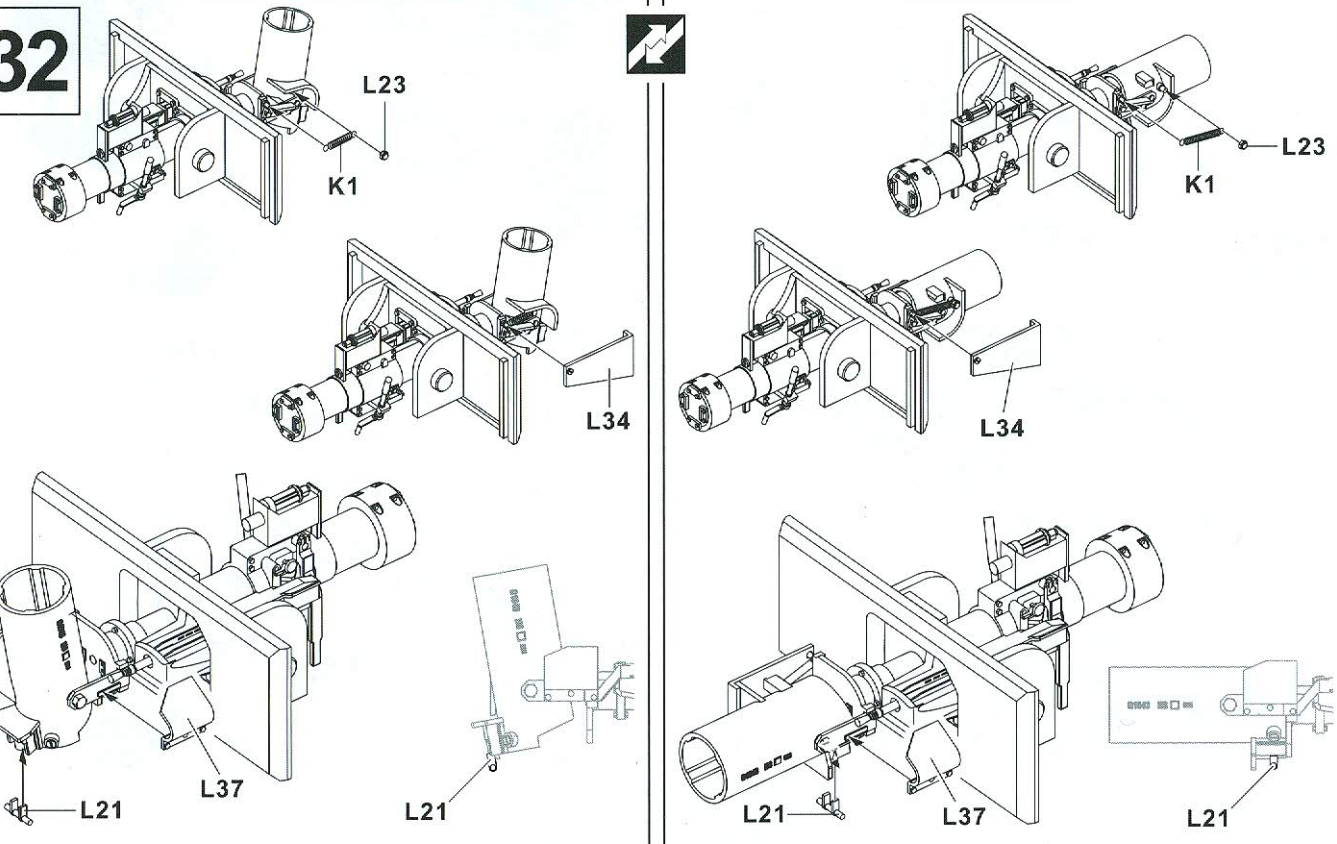

33

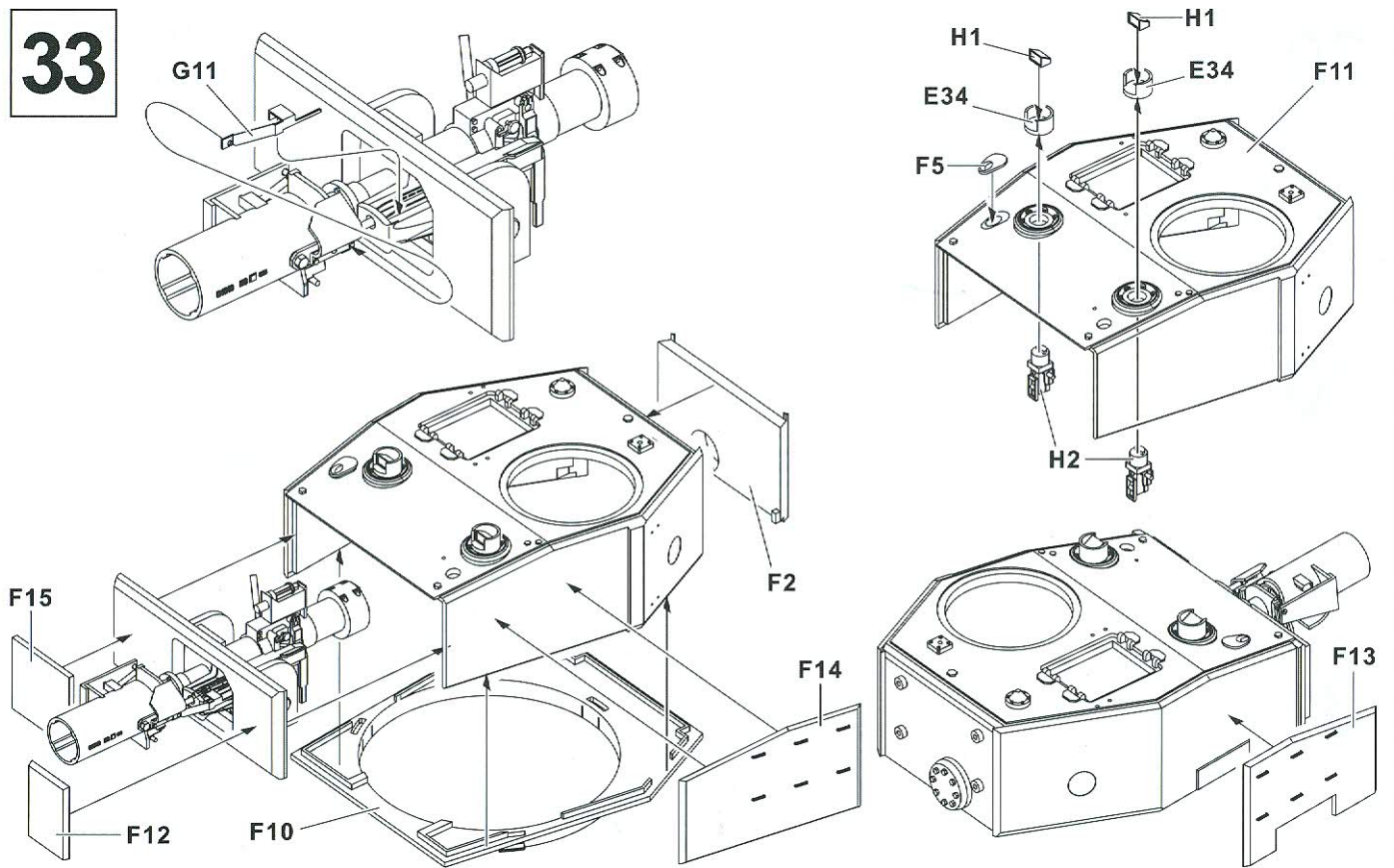

34

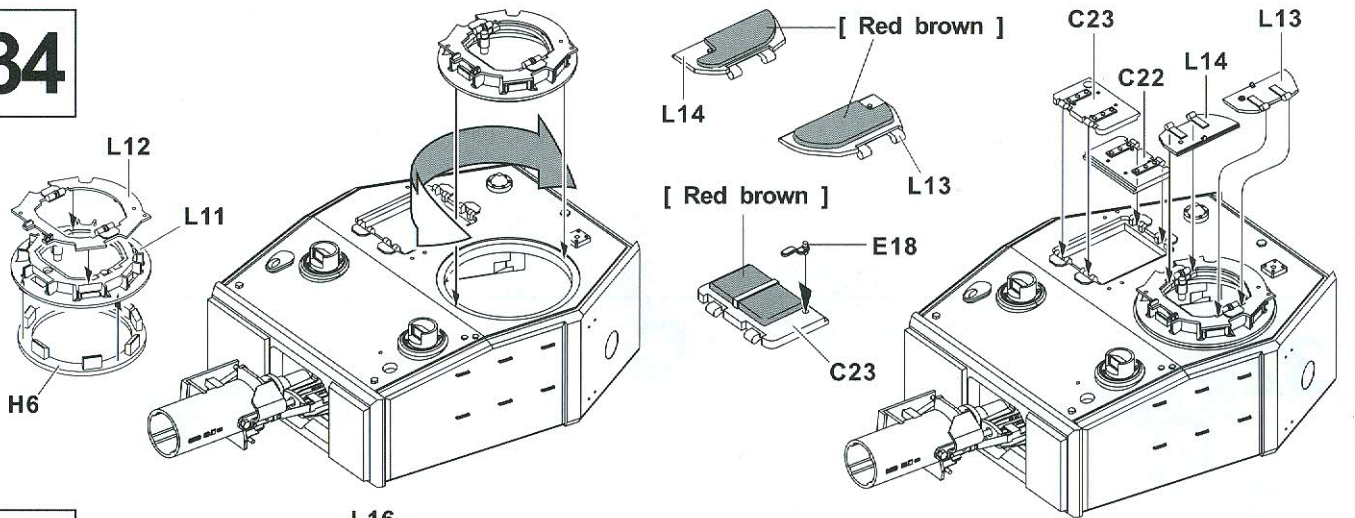

35

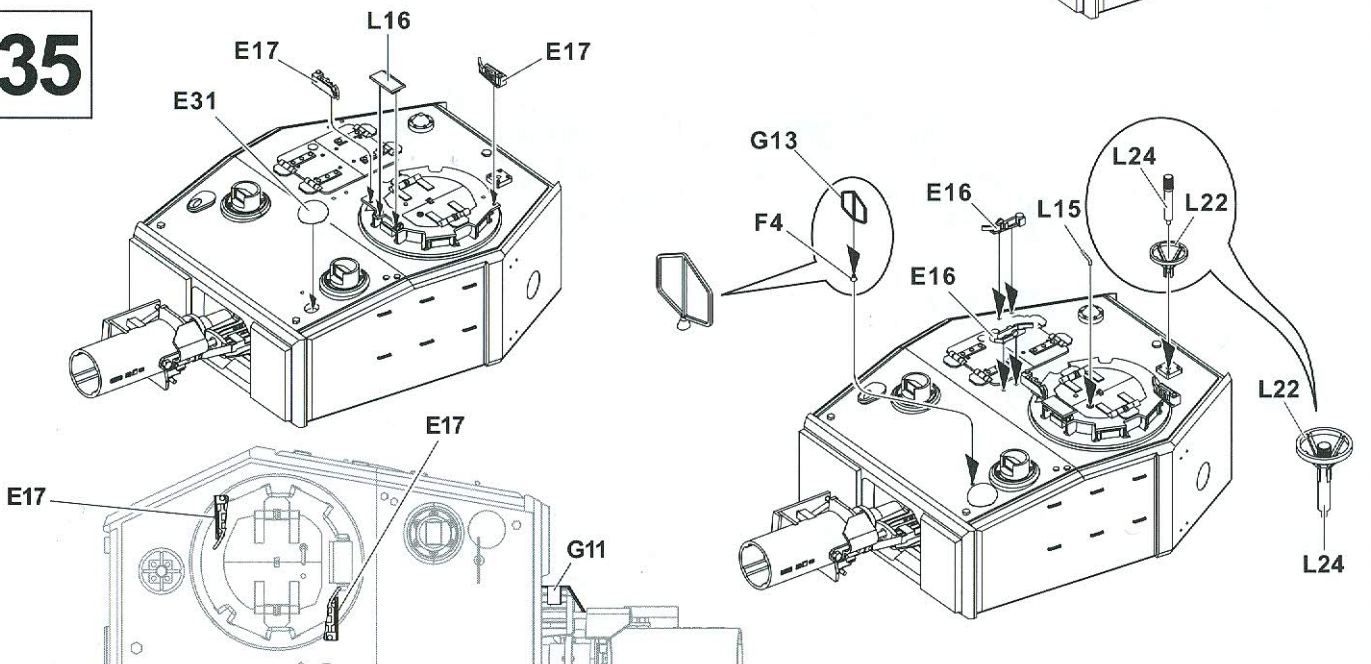

36

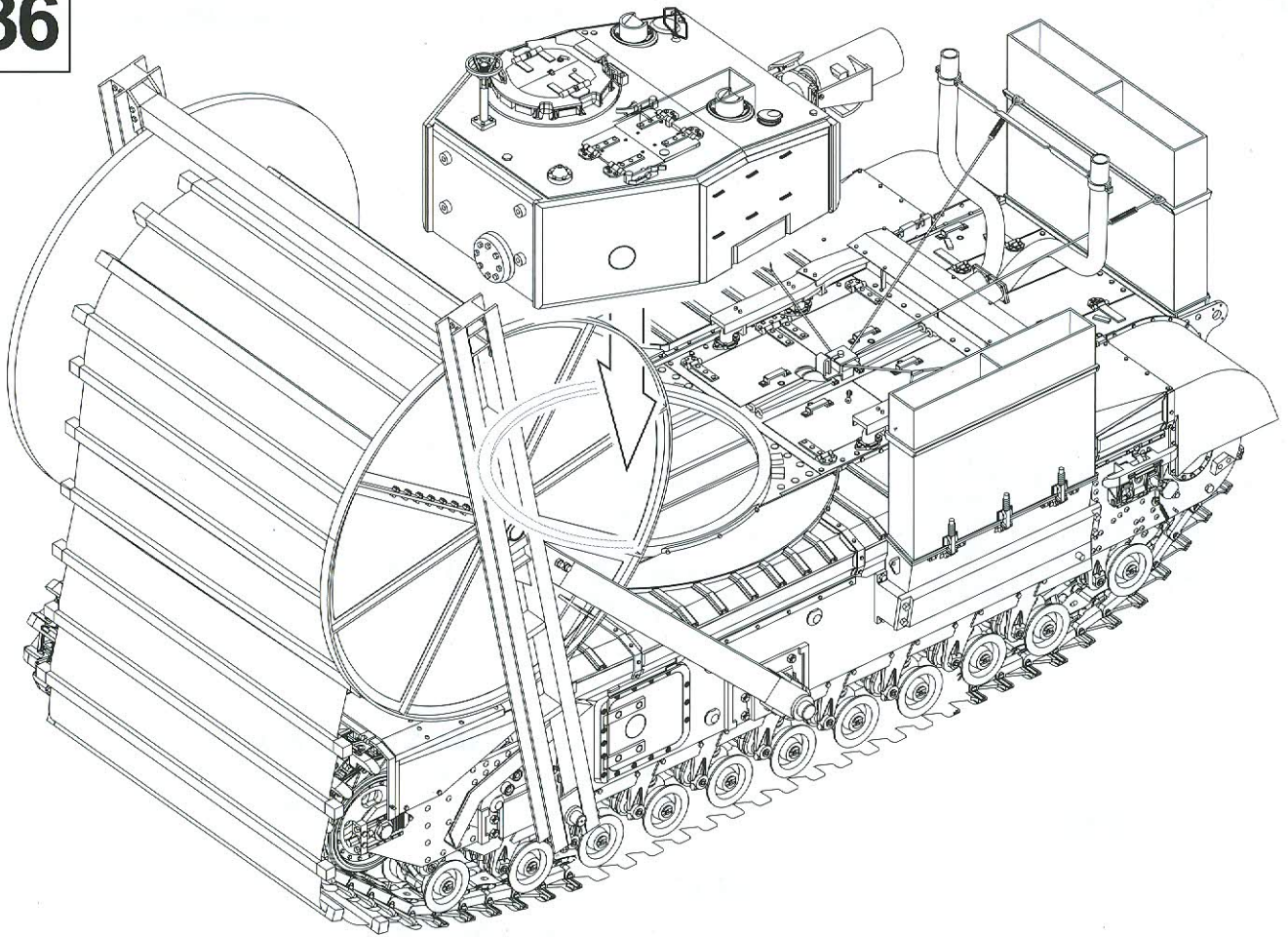

37

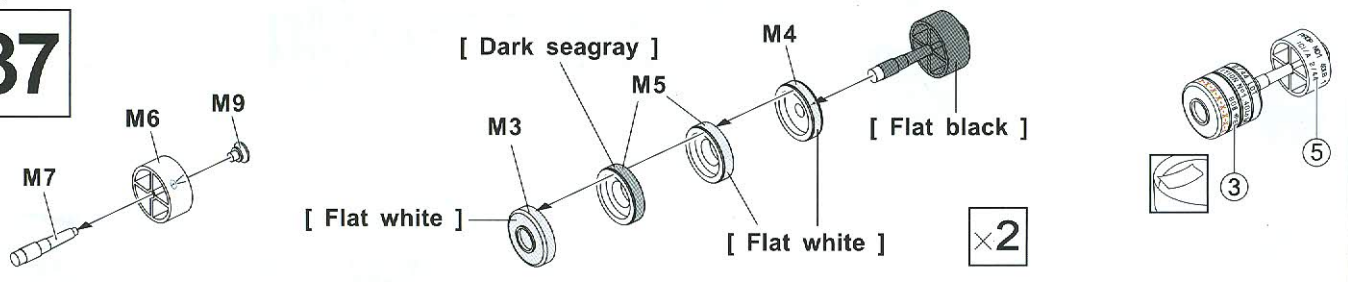

PAINTING

 Body Color: Dark Green 

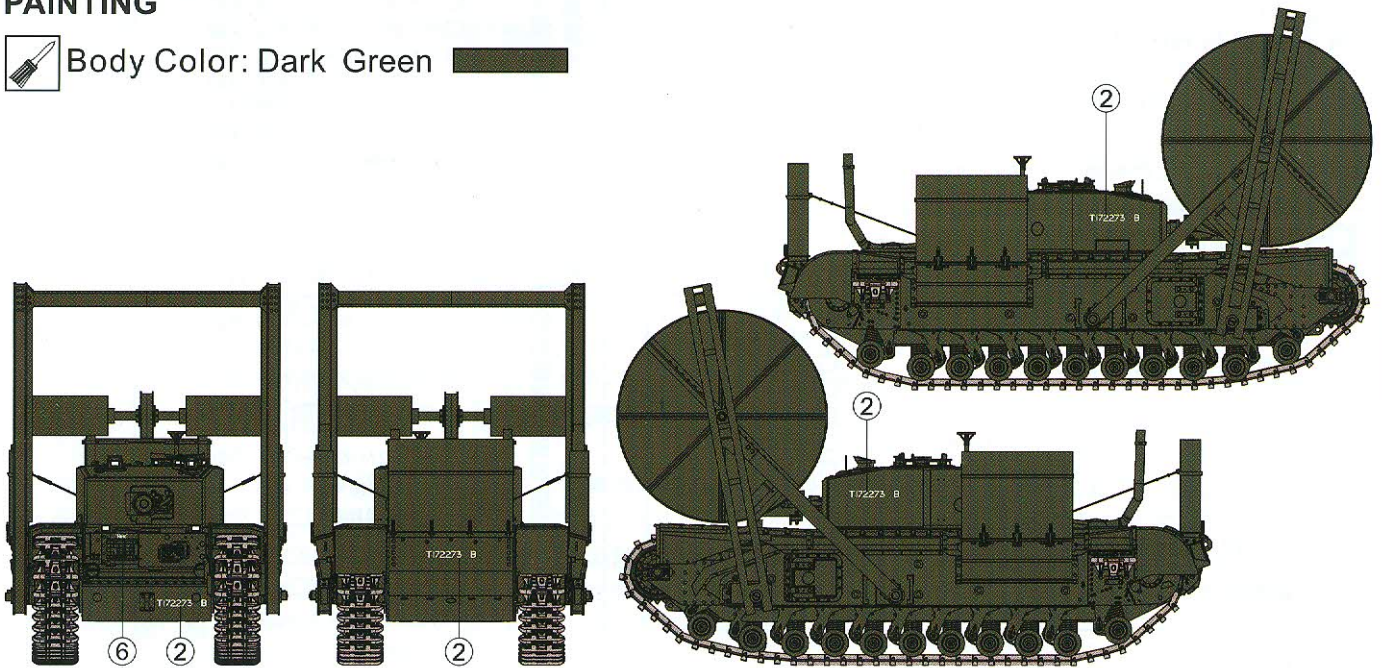

PARTS LIST 零件表

T X1

AF 35153

A X1

AF 35153

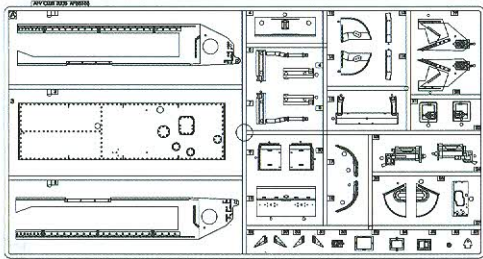

B X1

AF 35153

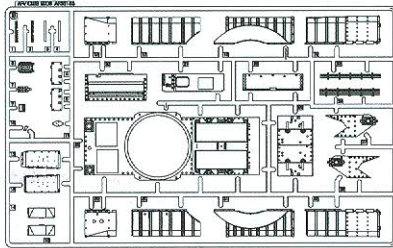

E X2

AF 35153

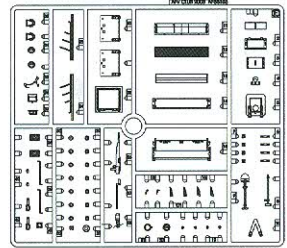

C X1

AF 35153

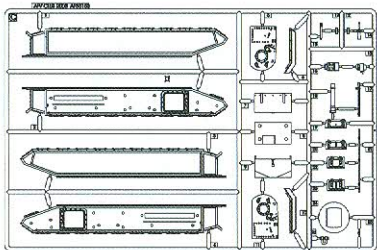

D X2

AF 35153

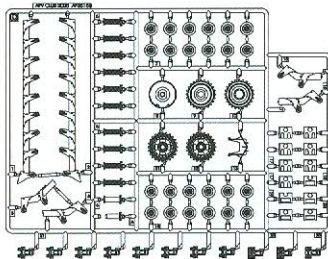

L X1

AF 35167

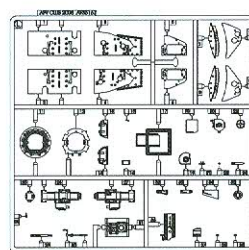

M X2

AF 35167

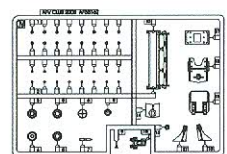

Z X10

AF 35274



G A X1

AF 35274



Y X1

AF 35274



N X1

AF 35167



K X22

AF 35153



F X1

AF 35153

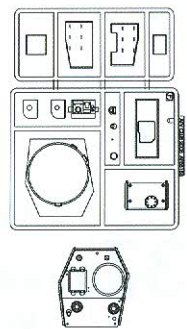

G X1

AF 35167



H X1

AF 35153



J X1

AF 35274



AB X2

AF 35274

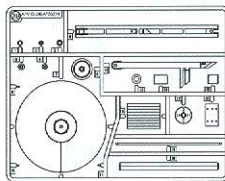

S X1

AF 35176

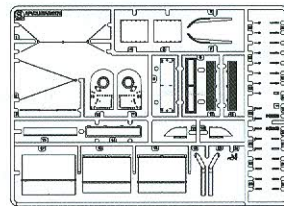

Instructions:

If for some reason, you are not fully satisfied or have questions concerning our product; Please use the form provide, and send it to our nearest representative or mail it directly to our office.

We will deal with that A.S.A.P.

限臺灣地區使用 For Taiwanese use only!



AF 35274
零件補充申請表

申請人
姓名 地址 電話

- AF 35153-A — NTS 280
- AF 35274-AB — NTS 220
- AF 35153-B — NTS 280
- AF 35153-C — NTS 240
- AF 35153-D — NTS 320
- AF 35153-E — NTS 210
- AF 35153-F — NTS 180
- AF 35167-G — NTS 220
- AF 35274-GA — NTS 120
- AF 35153-H — NTS 120
- AF 35274-J — NTS 160
- AF 35153-K — NTS 120
- AF 35167-L — NTS 280
- AF 35167-M — NTS 320
- AF 35167-N — NTS 60
- AF 35176-S — NTS 320
- AF 35153-T — NTS 280
- AF 35274-Y — NTS 160
- AF 35274-Z — NTS 80

+郵寄費 — NTS 80

(請填)總計NT\$ _____

零件補充原因:(請於□打√)

原包裝即 遺失或 毀損,

製作途中 遺失或 毀損,

其他原因 _____

總代理戰鷹企業有限公司收本公司將儘速為您處理。
請將本表與該部品相同金額之郵政匯票一同寄至。



AF 35274
Parts Replacement Form

- AF 35153-A
- AF 35274-AB
- AF 35153-B
- AF 35153-C
- AF 35153-D
- AF 35153-E
- AF 35153-F
- AF 35167-G
- AF 35274-GA
- AF 35153-H
- AF 35274-J
- AF 35153-K
- AF 35167-L
- AF 35167-M
- AF 35167-N
- AF 35176-S
- AF 35153-T
- AF 35274-Y
- AF 35274-Z

Reason for replacement: Missing

Broken

Signature: _____

