

PLASTIC MODEL KITS
LIMITED EDITION
CAT.NO.72123

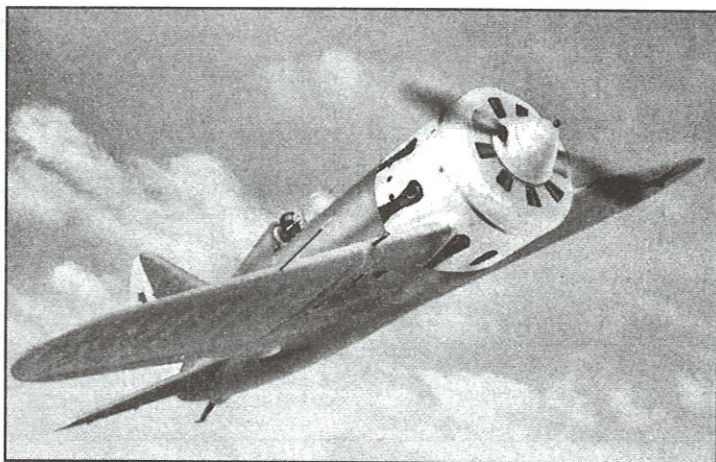

SPAN : 126 mm
LENGTH : 85 mm
PARTS : 34 pieces
SCALE:1/72



I-16 is the major fighter type of Red Army airforce during 1930s. It was built by the experimental design bureau named after N.N. Polikarpov in 1933. The distinguished peculiarity of this type was its high speed and good manoeuvrability for its time. I-16 had wooden fuselage with covering made of thin layers of wood. Wings and empennage were metal with linen cover. During the years of serial production 10292 machines of different modifications were built.

I-16 type 5 has been in serial production since 1935. The aircraft had M25 710 h.p. engine. Armament: 2 guns in the central part of fuselage and 200 kg bombs on external clip. The I-16 type was widely used during the war in Spain (1936-1938), China (1937-1940), Finland (1939-1940). During the war in Mongolia (May-September 1939) the fighters I-16 were the first in the aviation history to use rocket missiles. The I-16 aircraft took active part in the military actions of the initial stage of Great War.



И-16 - основной истребитель ВВС РККА в 30-е годы был построен в ОКБ Н. Н. Поликарпова в 1933 году. Его характерной особенностью являлась высокая для того времени скорость и хорошая маневренность. И-16 имел деревянный фюзеляж с обшивкой выклеенной из тонких слоев древесины. Крылья и оперения были металлическими с полотняной обшивкой. За годы серийного производства построено 10292 машины в различных модификациях.

Вариант И-16 тип 5 выпускался серийно с 1935 года. На самолете был установлен двигатель М25 мощностью 710 л.с. Вооружение : 2 пулемета в центроплане и 200 кг бомб на внешней подвеске. И-16 широко использовался во время войны в Испании (1936-1938гг.), в Китае (1937-1940гг.), в Финляндии (1939-1940 г.) В период сражений в Монголии (май-сентябрь 1939 г.) впервые в истории авиации истребители И-16 использовали реактивные снаряды. Самолеты И-16 принимали активное участие в боевых действиях первого периода Великой Отечественной Войны.

The model is executed on technology short run and is intended only for experienced modelers
Word-wide distributor for AMODEL kits :
IBG, Warszawa, Poland
Fax: (4822) 842-56-29 ; E-Mail: ibgsc@ibg.com.pl

Модель выполнена по технологии short run и предназначена только для опытных моделистов
Дистрибьютор моделей AMODEL :
IBG, Варшава, Польша
Факс: (4822) 842-56-29 ; E-Mail: ibgsc@ibg.com.pl



USED SYMBOLS / ИСПОЛЬЗУЕМЫЕ СИМВОЛЫ

1STAGES OF ASSEMBLY
ЭТАПЫ СБОРКИNUMBER PARTS
НОМЕР ДЕТАЛИTO PAINT
ОКРАСИТЬ**1**APPLY DECALS
НАНЕСТИ ДЕКАЛЬGLUE
КЛЕИТЬDON'T GLUE
НЕ КЛЕИТЬVERSION
ВАРИАНТMAKE A HOLE
ВЫПОЛНИТЬ ОТВЕРСТИЕDETACH WITH KNIFE
ОТДЕЛИТЬ НОЖОМSHAPE WITH HOT KNIFE
ФОРМОВАТЬ ГОРЯЧИМ
НОЖОМ**2x**QUANTITY OF
OPERATIONS (PARTS)
КОЛИЧЕСТВО
ОПЕРАЦИЙ (ДЕТАЛЕЙ)OPTIONAL
НА ВЫБОР

USED PAINTS / ИСПОЛЬЗУЕМЫЕ КРАСКИ

HUMBROL 11
SILVER
СЕРЕБРИСТЫЙHUMBROL 33
BLACK
ЧЕРНЫЙHUMBROL 53
GUNMETAL
СТАЛЬНОЙ СЕРЫЙHUMBROL 113
RUST
РЖАВЧИНАHUMBROL 64
LIGHT GREY
СВЕТЛО СЕРЫЙHUMBROL 62
LEATHER
КОЖАHUMBROL 65
LIGHT BLUE
СВЕТЛО-ГОЛУБОЙHUMBROL 30
DARK GREEN
ТЕМНО ЗЕЛЕНЫЙHUMBROL 27003
POLISHED STEEL
ПОЛИРОВАННАЯ СТАЛЬHUMBROL 34
WHITE
БЕЛЫЙHUMBROL 147
LIGHT GREY
СВЕТЛО СЕРЫЙHUMBROL 24
YELLOW
ЖЕЛТЫЙHUMBROL 63
SAND
ПЕСОЧНЫЙHUMBROL 186
BROWN
КОРИЧНЕВЫЙ

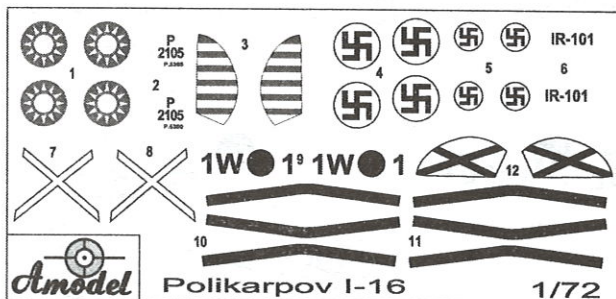

DECALS FOR FIVE VERSIONS OF COLOURING
ДЕКАЛЬ ДЛЯ ПЯТИ ВАРИАНТОВ ОКРАСКИ

34 DETAILS FOR ASSEMBLY OF ONE MODEL
34 ДЕТАЛИ ДЛЯ СБОРКИ ОДНОЙ МОДЕЛИ

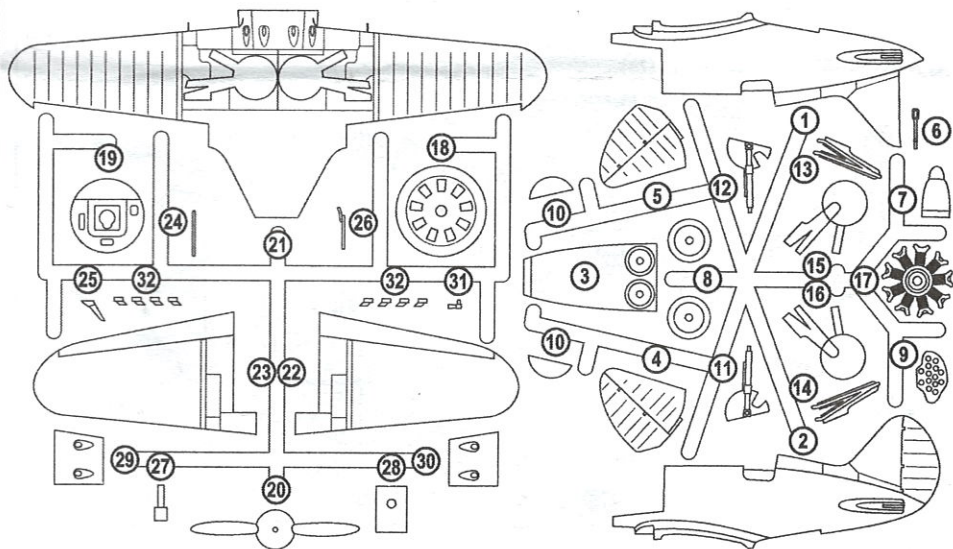

1 **3** **6** **7**

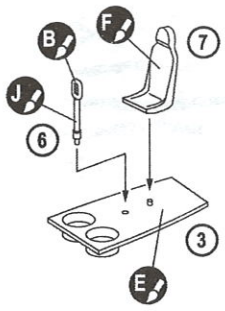

2 **1** **2** **4** **5** **9** **19** **31**

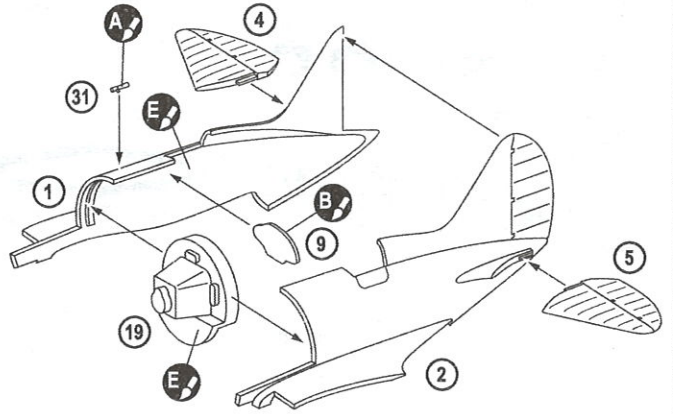

3 **17** **18** **20** **21** **22** **23** **27** **28** **29** **30** **8x** **32** **1** **2**

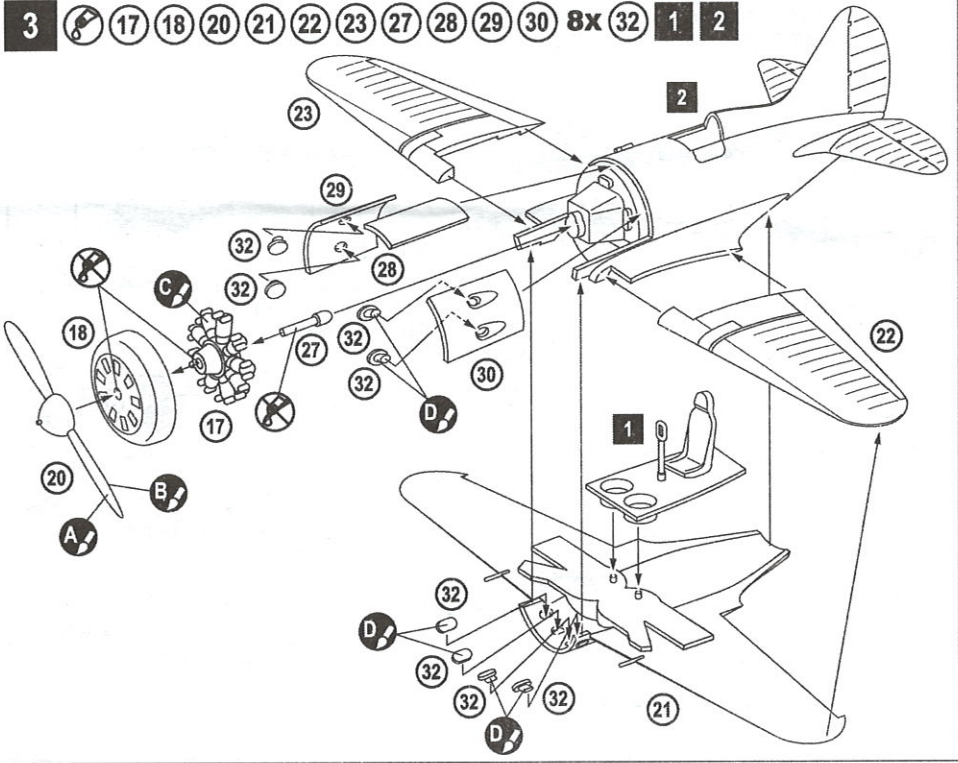

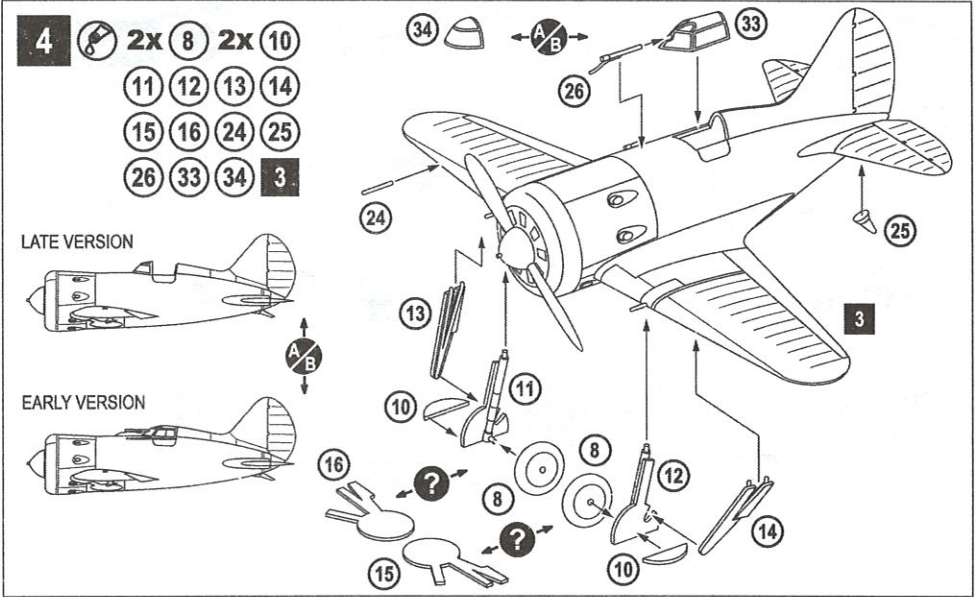

THE SCHEME OF COLOURING / СХЕМА ОКРАСКИ

I-16 type 5, Air Force USSR, summer 1941
И-16 тип 5, ВВС СССР, лето 1941 года

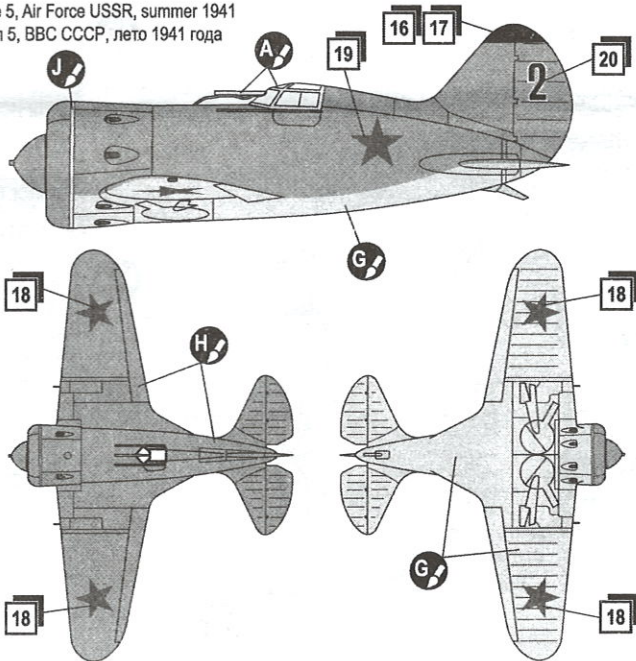

HUMBROL 11
SILVER
СЕРЕБИСТЫЙ



HUMBROL 65
LIGHT BLUE
СВ.-ГОЛУБОЙ



HUMBROL 30
DARK GREEN
ТЕМ. ЗЕЛЕНЫЙ



HUMBROL 27003
POLISHED STEEL
ПОЛИР. СТАЛЬ

I-16 type 5, Air Force USSR, Baltic, summer 1941
 И-16 тип 5, ВВС СССР, Балтика, лето 1941 года

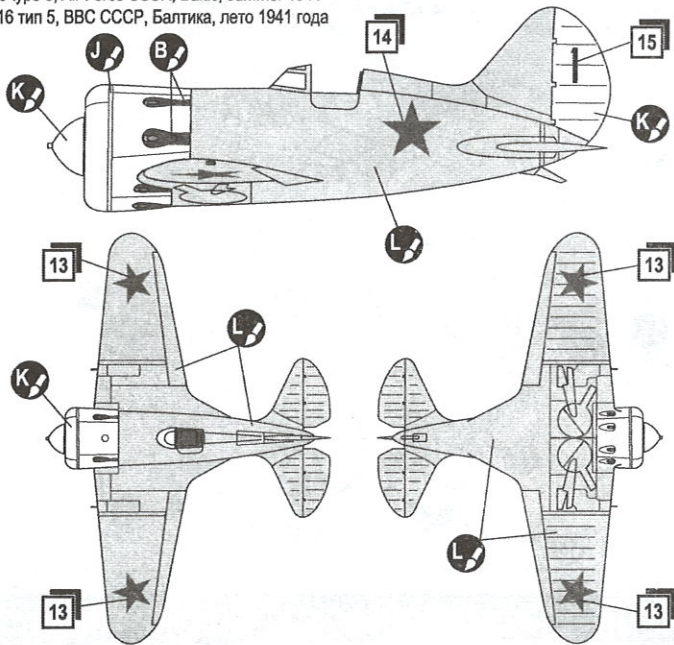

- B**  HUMBROL 33
BLACK
ЧЕРНЫЙ
- J**  HUMBROL 27003
POLISHED STEEL
ПОЛИР. СТАЛЬ
- K**  HUMBROL 34
WHITE
БЕЛЫЙ
- L**  HUMBROL 147
LIGHT GREY
СВЕТЛО СЕРЫЙ

I-16 type 5, Chinese Air Force, 1938
 И-16 тип 5, Китайские ВВС, 1938 год

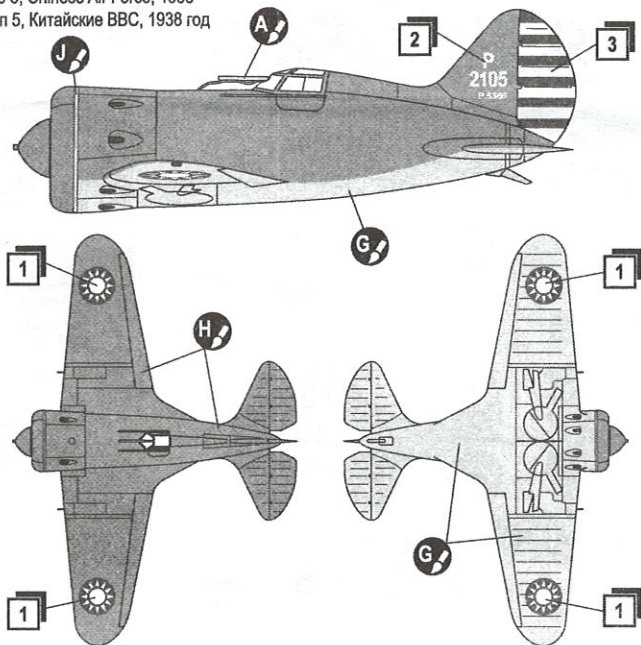

- A**  HUMBROL 11
SILVER
СЕРЕБИСТЫЙ
- G**  HUMBROL 65
LIGHT BLUE
СВ.-ГОЛУБОЙ
- H**  HUMBROL 30
DARK GREEN
ТЕМ. ЗЕЛЕНЫЙ
- J**  HUMBROL 27003
POLISHED STEEL
ПОЛИР. СТАЛЬ

I-16 type 5, Finland Air Force, 1942
И-16 тип 5, Финские ВВС, 1942 год

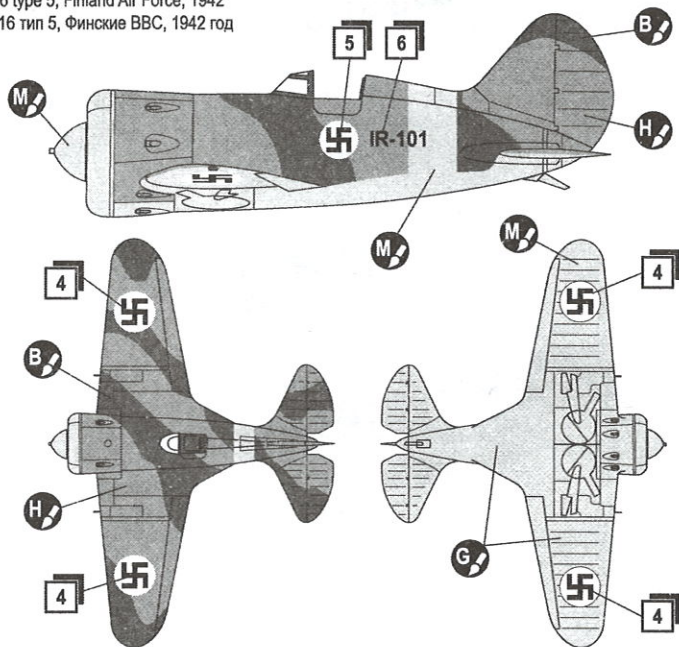

B 
HUMBROL 33
BLACK
ЧЕРНЫЙ

G 
HUMBROL 65
LIGHT BLUE
СВ.-ГОЛУБОЙ

H 
HUMBROL 30
DARK GREEN
ТЕМ. ЗЕЛЕНЬКИЙ

M 
HUMBROL 24
YELLOW
ЖЕЛТЫЙ

I-16 type 5, Spanish Air Force, 1939
И-16 тип 5, Испанские ВВС, 1939 год

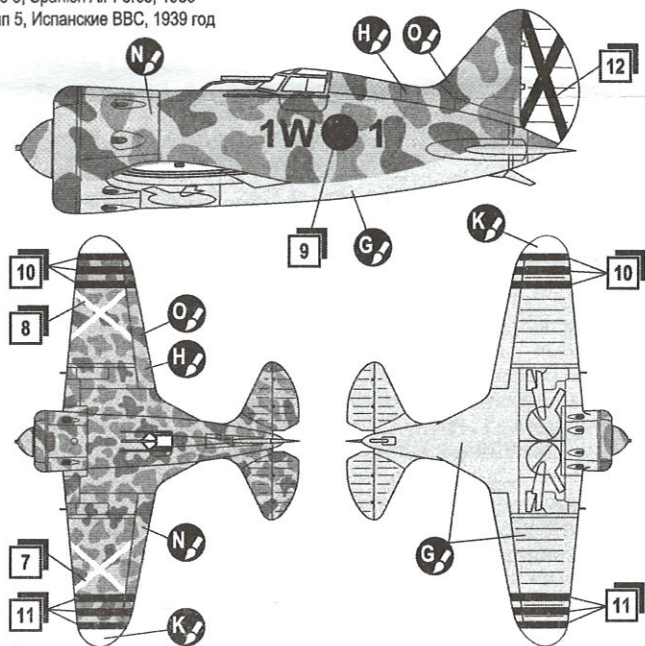

G 
HUMBROL 65
LIGHT BLUE
СВ.-ГОЛУБОЙ

H 
HUMBROL 30
DARK GREEN
ТЕМНО ЗЕЛЕНЬКИЙ

K 
HUMBROL 34
WHITE
БЕЛЫЙ

N 
HUMBROL 63
SAND
ПЕСОЧНЫЙ

O 
HUMBROL 186
BROWN
КОРИЧНЕВЫЙ

