

- 11 Remove the flexible tracks from the runners. Place the pins on one end through the holes in the opposite end. Using a heated blade, melt the end of each pin to secure the track. Slide the track over the wheels as shown. Cement parts 26 and 27 to hull sides.

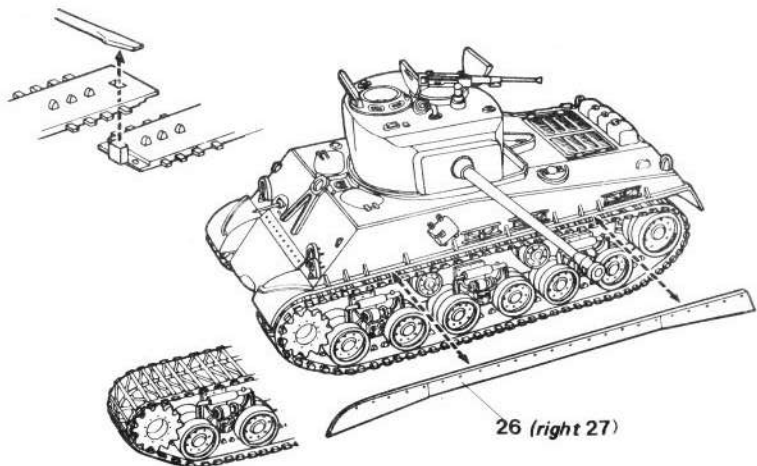

**PART DRAWINGS AND PART NUMBERS**  
(Before Assembling Your Kit)

Read these instructions carefully before assembling your model and check the exact fit of the parts before cementing. Clean off excess plastic, if any, with a sharp knife or a file. Since many tiny parts are included, check them with the assembly drawing before assembling. Do not tear off parts from the stem, but cut them off carefully with a knife or clippers. Do not cut off all of the parts at the beginning, but cut each part to be assembled, one by one, to assure each part being properly identified. Do not use too much cement since surplus adhesives can spoil the finish.

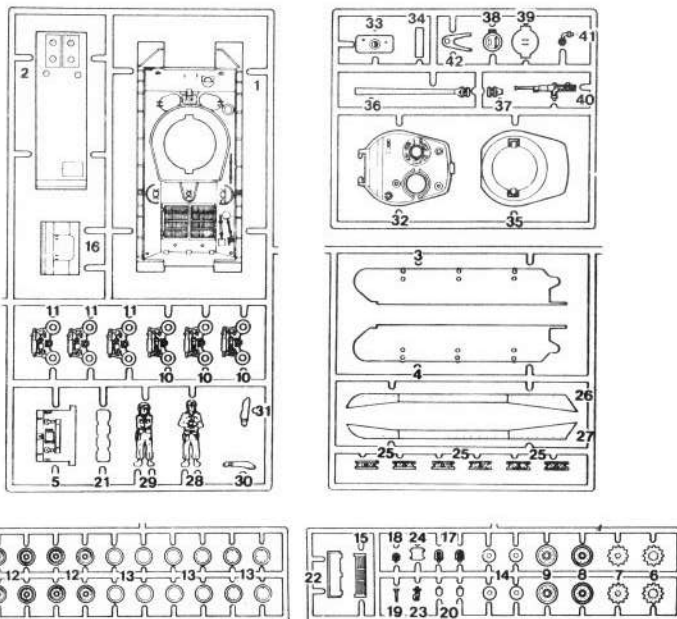

# M-4 A3E8 SHERMAN

1/72 SCALE

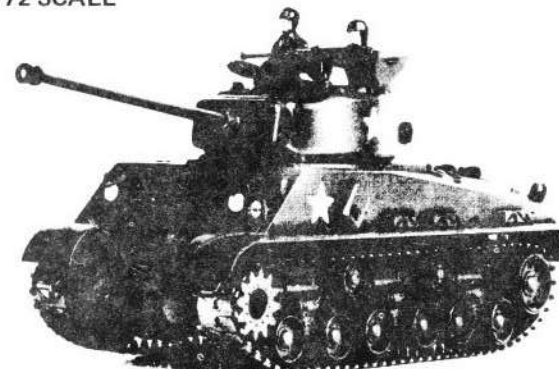

715

The American medium tank known as the M4 Sherman has the distinction of being the most famous and the most widely produced tank in the history of mechanized warfare. Total production of all versions of this versatile armored vehicle amounted to the staggering sum of 53,962 units. Of these the M4A3 subtype was built in greater quantities than the other nine versions, 11,424 being constructed. No less than eleven factories were involved in assembling Sherman tanks during World War II. Despite the variety of manufacturers and model types, the M4's differed only in engines and minor details.

First tested in October, 1941, the M4 was placed in production as a replacement for the M3 Lee/Grant type and had its first taste of combat one year later at Second Alamein in British service. The M4 was found on all combat fronts from Asia to Europe by the conclusion of the War. Several thousand Shermans were sold to Britain and Russia under Lend-Lease terms and a few even found their way into German hands where they were used against the Allies.

Technically, the medium-weight Shermans could not combat the heavier German Tiger or Panther tanks, but due to carefully planned tactics, aerial support, sufficient reserves and an overwhelming quantity, the M4 played a major role in defeating the Axis war machine.

The M4 remained an effective weapon even after World War II had faded into the past. In 1967 Shermans were called into action again during the Israeli-Egyptian Six-Day War, where once again it emerged victorious.

**SPECIFICATIONS**

- Loaded Weight: 71,175 lbs
- Length: 24 feet 8 inches
- Engine: Ford GAA 500 hp V-8 (Some Shermans were powered by Continental aircraft engines or various diesels.)
- Maximum Road Speed: 26 mph
- Armament: 76 mm High Velocity gun  
Two .30 Cal Machine guns  
One .50 Cal Anti-Aircraft gun



1510 W. 228TH STREET, TORRANCE, CAL 90501

**PAINTING SUGGESTIONS**

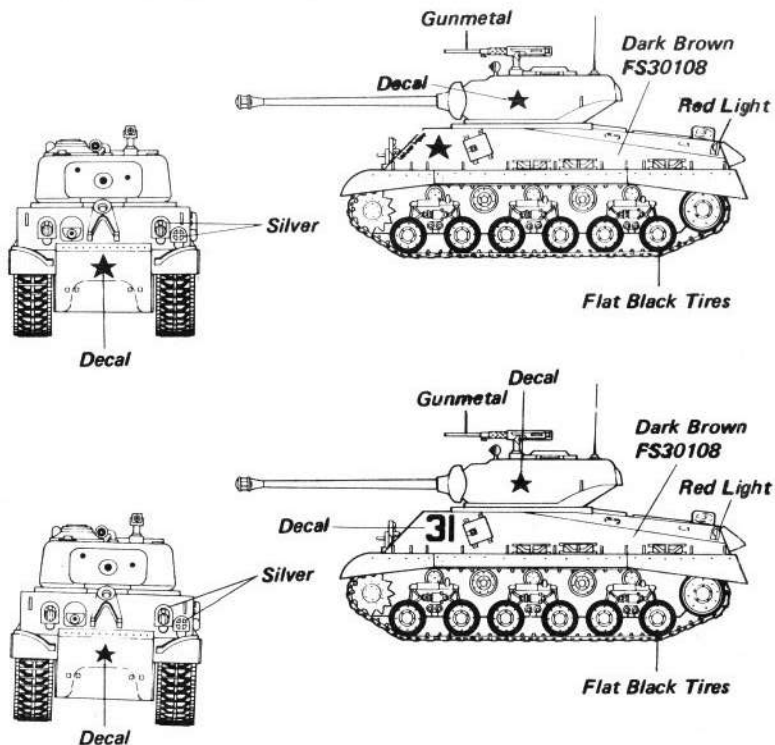

- 1** Make six sets of bogies by sliding axles on 12 through holes in 10 then cement pins on 13 to holes in axles on 12.

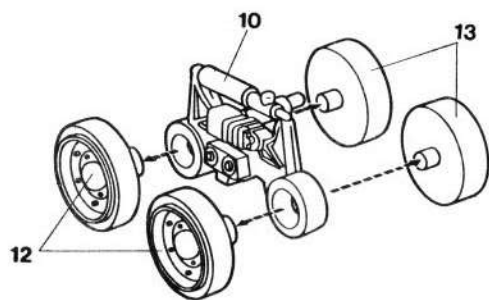

- 2** Cement 15 and 23 to 5.

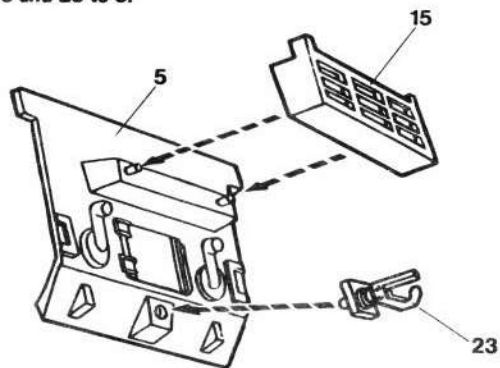

- 3** Cement hull bottom 2 to 4 (Locate by placing pins on 2 to pins on 4 as shown by arrows.) Cement assembly from STEP 2 in place as shown then cement side 3 to hull bottom.

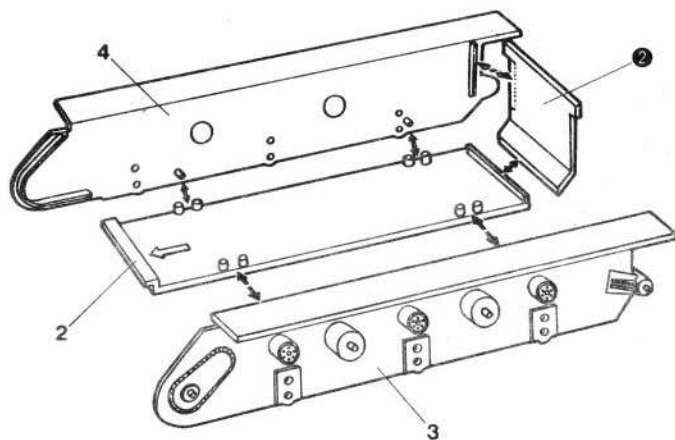

- 4** Cement assembled bogies to hull sides as indicated. Cement two 14's to round pads on each side. Cement 8 and 9 together then to rear pins on hull, one set to each side. Cement 6 and 7 together then cement one set to forward pins on each hull side. Cement 1 to top of assembly then cement 16 to the hull front.

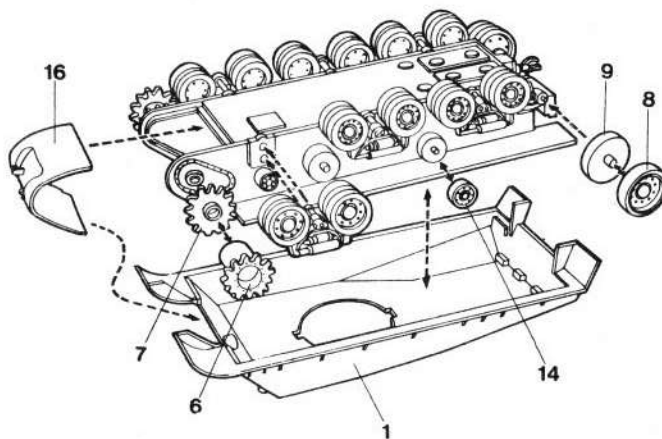

- 5** Cement two 17's to front as shown, then cement 18 and 19 in place. Cement 42 in front as shown. Cement 24 and three 25's to side in positions shown.

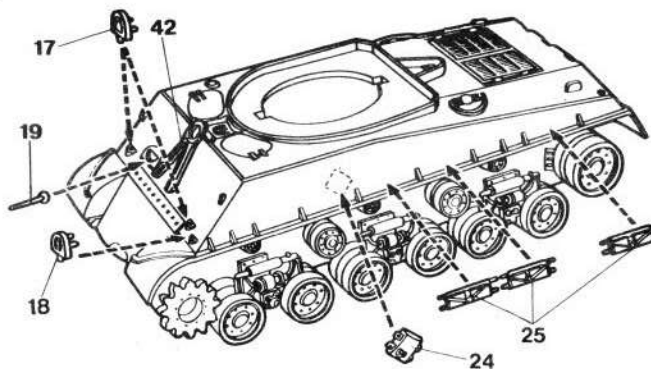

- 6** Cement two 20's in place then cement 21 and 22 as indicated. Cement three 25's to side.

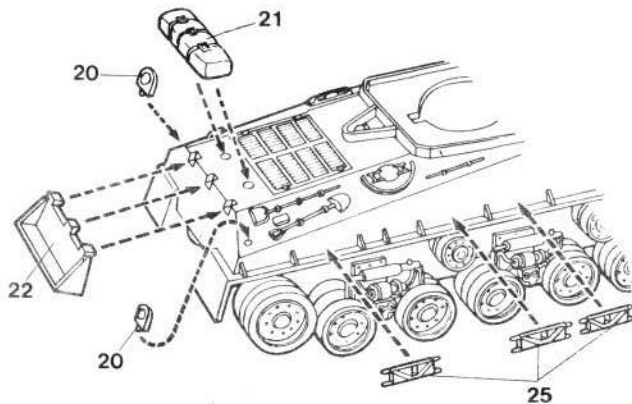

- 7** Place ribs inside 33 over pins in front of 32 then carefully cement 34 to 33. (33 should swivel!) Cement 35 to 32.

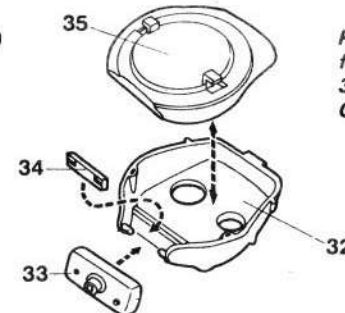

- 8** Cement 37 to 36 then cement 36 to turret front. Hatches, 38 and 39 may be cemented open or closed. (39 must be cut in half if opened position is desired.) Cement 40 and 41 in place.

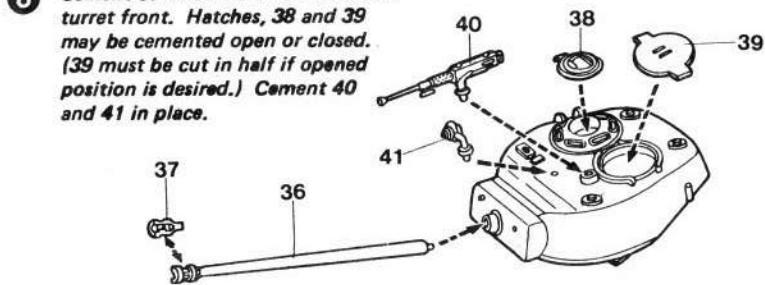

- 9** Cement 30 and 31 to 29. If hatch is open figure may be cemented inside. If 28 is to be placed in turret his legs must be cut off as shown by dotted lines.

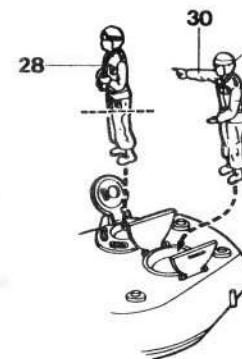

Uniforms are Tan FS30372  
Inside of hatches are White

- 10** Place turret assembly from STEP 8 on hull assembly. Place tabs on turret in slots on hull and twist to lock turret.

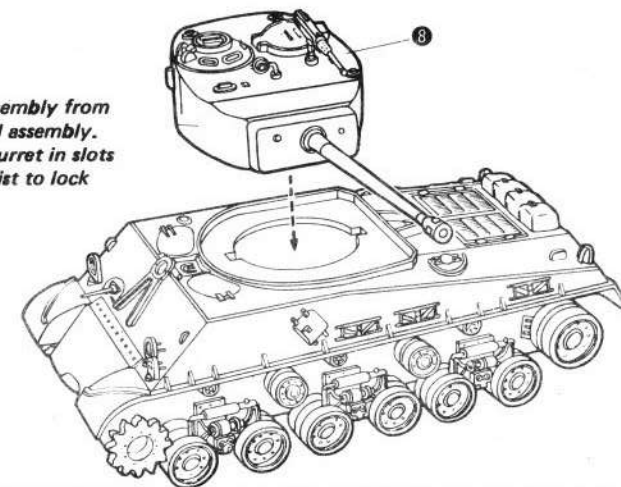

31



31



INTERNATIONAL  
FRANCHISES



**MADE IN JAPAN**