

KIT 5206

1/72 SCALE MASSTAB 1:72 ESCALA 1/72  
SCHAAL 1:72 1/72 ECHELLE SKALA 1/72 SCALA 1/72

MONOGRAM MODELS, INC. Morton Grove, Ill. Copyright © 1983. All rights reserved. Made in U.S.A. 5206-0200

The F-16XL represents an evolutionary advancement over the design of the supersonic F-16 "Fighting Falcon." Visually, the new aircraft is distinguished by a revolutionary wing design that was developed by General Dynamics engineers with the assistance of NASA aerodynamicists. This unique "Cranked Arrow" design provides improved handling characteristics throughout the flight envelope, while the increased surface area of the wing increases combat range and payload capability.

Due to the results of preliminary design work, General Dynamics decided to proceed with the de-

velopment of a full-size prototype during November of 1980, and this aircraft first rolled out in July of 1982, less than two years after work began. Although this new design was not developed specifically for an Air Force program, the military is obviously quite interested in the F-16XL.

Your model portrays the prototype F-16XL. It is armed with two "Sidewinder" air-to-air missiles and four AMRAAM missiles. The actual aircraft is powered by a Pratt and Whitney F100 engine, and a 20 millimeter gun is fitted internally.

### READ THIS BEFORE YOU BEGIN

- Study the assembly drawings.
- Each plastic part is identified by a number.
- Check the fit of each piece before cementing in place.
- Do not use too much cement to join parts.
- Use only cement for polystyrene plastic.
- Model may be painted to match photos on box.
- Allow paint to dry thoroughly before handling parts.
- Scrape paint from areas to be cemented.
- For better paint and decal adhesion, wash the plastic parts in a mild detergent solution. Rinse and let air dry.

### ALLGEMEINE HINWEISE

- Die Anordnung der Bauteile ist aus den Zeichnungen der Anleitung ersichtlich.
- Jedes Plastikteil ist durch eine Nummer gekennzeichnet.
- Die Teile vor dem Verkleben ungeleimt zusammenhalten, um ihren Passitz zu prüfen.
- Klebstoff nicht zu dick auftragen.
- Nur Modellbaukleber für Polystyrol verwenden.
- Man kann das Modell nach den Fotos auf der Schachtel anstreichen.
- Bemalte Teile vor der Weiterverwendung gut trocknen lassen.
- Die Farbe muss von allen späteren Klebestellen abgeschabt werden.
- Damit die Farbe und die Abziehbilder besser kleben, sind die Plastikteile in einer milden Seifenlauge zu waschen. Dann abspülen und an der Luft trocknen lassen.

### LEA ESTO ANTES DE EMPEZAR

- Estudie los dibujos de ensamble.
- Cada pieza de plástico se identifica por un número.
- Verifique que cada pieza encaje bien antes de pegar en posición.

- No use demasiado pegamento para unir las piezas.
- Use únicamente pegamento para plástico de poliestirena.
- El modelo puede pintarse de acuerdo con las fotografías de la caja.
- Permita que se seque la pintura completamente antes de tocar las piezas.
- Raspe la pintura de las superficies que serán pegadas.
- Para una mejor fijación de la pintura y de las calcomanías, lávase las piezas plásticas en una solución de detergente suave. Enjuáguese y déjense secar al aire.

### LEES DIT ALVORENS TE BEGINNEN

- Bestudeer de bouwtekening.
- Elk plastic onderdeel is genummerd.
- Controleer de passing van elk deel voor het lijmen.
- Gebruik niet te veel lijm.
- Alleen lijm voor polystyreen plastic gebruiken.
- Men kan model verven zoals aangeduid op de doos.
- Laat de verf van de te verwerken delen steeds goed drogen.
- Verwijder de verf van te lijmen oppervlakken.
- Zodat de verf en etiketten beter zullen plakken, was de plasticke delen in een milde seep oplossing. Spoel en laat in de openlucht opdrogen.

### LISEZ CE QUI SUIT AVANT DE COMMENCER LE MONTAGE

- Etudiez les schémas d'assemblage.
- Chaque pièce plastique porte un numéro d'identification.
- Contrôlez que chaque pièce soit bien conforme avant de la coller à sa place.
- N'utilisez pas trop de colle pour réunir les pièces.
- Utilisez uniquement une colle spéciale pour polystyrène.

- Le modele peut être peint conformément aux photos sur la boîte.
- Laissez sécher la peinture complètement, avant de manipuler les pièces.
- Grattez la peinture sur les surfaces devant être collées.
- Pour assurer la meilleure adhesion possible de la peinture et des décalcomanies, lavez les pièces de plastique avec une légère solution savonneuse. Rinses et laissez sécher à l'air.

### LAS DET HAR INNAN DU BORJAR BYGGA

- Studera monteringskisserna.
- Alla plastdelar har identifikationsnummer.
- Kolla noga att delarna passar före limningen.
- Stryk inte för mycket lim på delarna.
- Använd endast lim för polystyren-plast.
- Modellerna kan målas enligt fotona på kantomterna.
- Lat färgen torka ordentligt före limningen.
- Skrapa bort färgen på de ytor som ska limmas.
- För bättre vidhäftning av färg och dekalmarken rengör plastdelarna i en mild tvättmedelslösning. Skölj och låt lufttorka.

### DA LEGGERE PRIMA DI INIZIARE

- Studia le illustrazioni.
- Ogni pezzo è identificato da un numero.
- Controlla l'incastro di ogni pezzo prima di incollarlo.
- Non usare troppa colla per unire i pezzi.
- Adopera solamente colla per materie plastiche.
- Il modello si può dipingere seguendo la fotografia sulla scatola.
- Aspetta che la vernice sia completamente asciutta prima di maneggiare le parti.
- Asporta la vernice dai punti dove applicherai la colla.
- Per una migliore aderenza di vernice e decalcomanie, lavare le parti in plastica in soluzione detergente non abrasiva. Risciacquare e lasciar asciugare all'aria.



REPEAT SEVERAL TIMES  
ARBEITSSCHNITT MÖHNERALS WIEDERHOLEN  
REPTA VARIAS VECES  
ENIGE KEREN HERHALEN  
A REPTER PLUSIEURS FOIS  
ARBEITSMOMENT SOM IPPREPAS  
RIPETI DIVERSE VOLTE



REMOVE AND THROW AWAY  
ENTFERNEN (ABFALL)  
DUIE Y THE  
VERWILDEREN EN WEGDOOEN  
A RETNER ET BETER  
AVLAGNAS OCH MAKULERAS  
RIMUOVI ED ELIMINA



OPTIONAL PARTS  
BAUTEILE NACH WAHL  
PEZAS OPCIONALES  
KEUZE-ONDERDELEN  
PRECES EN OPTION  
VALFRÅ DELAR  
PARTI FACOLTATIVE



DECAL (DIP IN WATER)  
ABZIEHBILD  
DECALCOMANIA (MOJE CON AGUA)  
TRANSFERS (IN WATER DOPEN)  
DECALCOMANIE (A PLONGER DANS L'EAU)  
OSKAL (DOPPAS I VATTEN)  
DECALCOMANIA (IMMERGI IN ACQUA)

A	RED	ROT	ROJO	ROOD	ROUGE	RÖD	ROSSO
B	WHITE	WEISS	BLANCO	WIT	BLANC	VIT	BIANCO
C	BLUE	BLAU	AZUL	BLAUW	BLEU	BLA	BLU
D	DARK GRAY	DUNKELGRAU	GRIS OSCURO	DONKER GRIJS	GRIS FONCE	MÖRKGRA	GRIGIO SCURO
E	GRAY	GRAU	GRIS	GRIJS	GRIS	GRA	GRIGIO
F	LIGHT GRAY	HELLGRAU	GRIS CLARO	LICHT GRIJS	GRIS CLAIR	LJUSGRA	GRIGIO CHIARO
G	DARK GREEN	DUNKELGRÜN	VERDE OSCURO	DONKERGRÖEN	VERT FONCE	KÖPPARGRÖEN	VERDE SCURO
H	FLAT BLACK	GLANZLOSES SCHWARZ	NEGRO APAGADO	GLANZLOOS ZWART	NOIR TERNE	MATTSVART	NERO OPACO
J	METALLIC	METALLIC	METALICO	METALLIEK	METALLIC	METALLGLANS	METALLICO

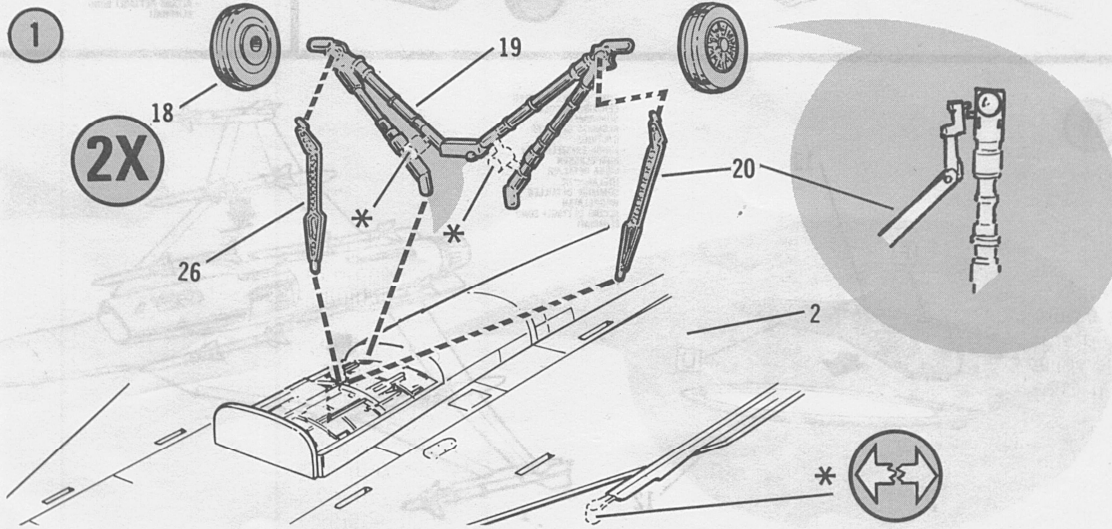

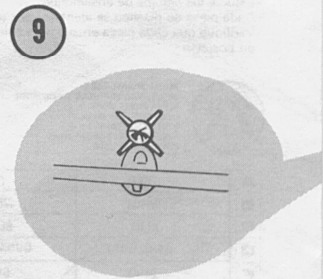
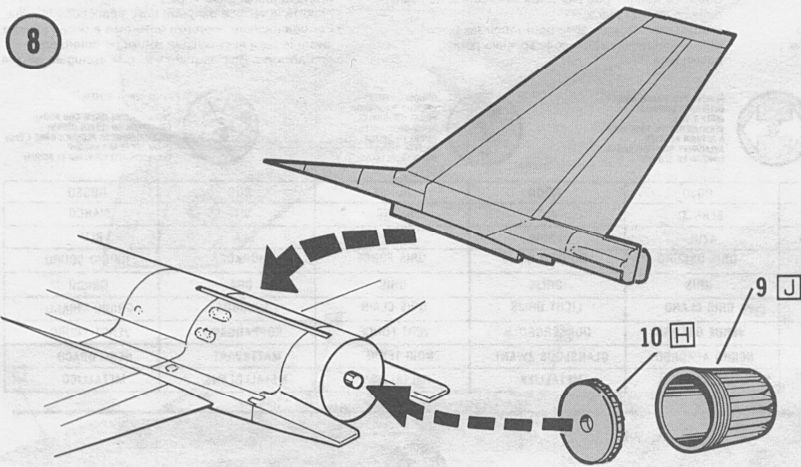
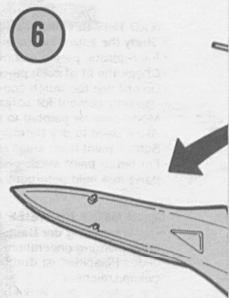
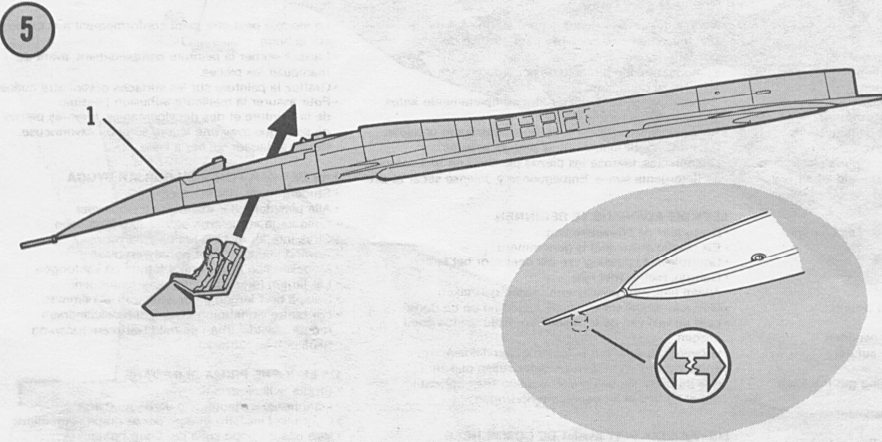
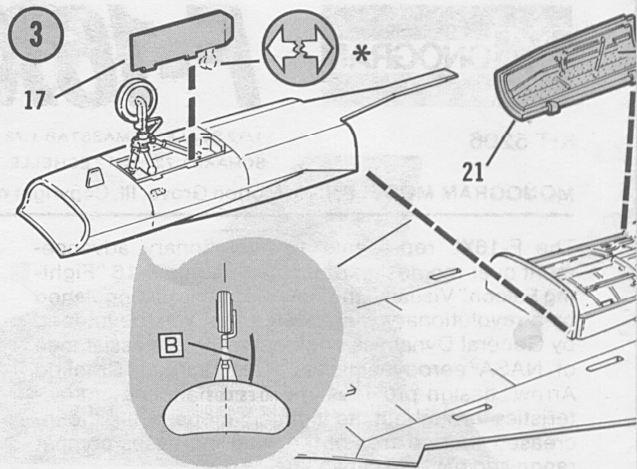
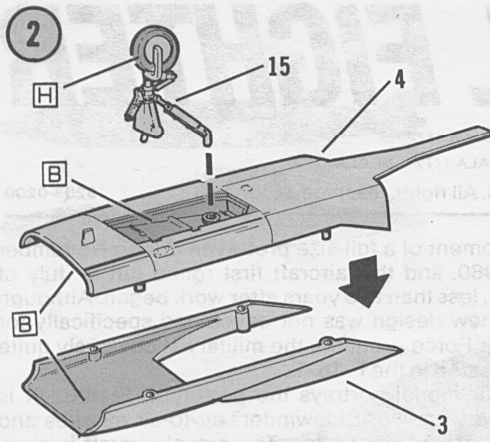

• SOME DETAILS OMITTED  
 • CERTAINS DETAILS SUPPRIMÉS  
 • ALGUNOS DETALLES OMITIDOS  
 • ENIGE EINSZELHEITEN AUSGELASSEN  
 • VISSA DETALJER UTELÄMNADE  
 • SOMMIGGE DETAILLES WEGGELATEN  
 • ALCUNI DETTAGLI SONO ELIMINATI

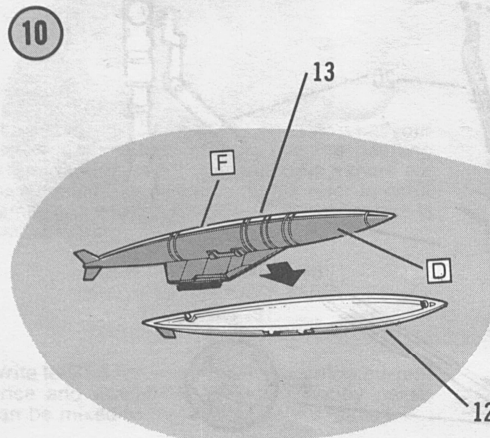

• SOME DETAILS OMITTED  
 • CERTAINS DETAILS SUPPRIMÉS  
 • ALGUNOS DETALLES OMITIDOS  
 • ENIGE EINSZELHEITEN AUSGELASSEN  
 • VISSA DETALJER UTELÄMNADE  
 • SOMMIGGE DETAILLES WEGGELATEN  
 • ALCUNI DETTAGLI SONO ELIMINATI

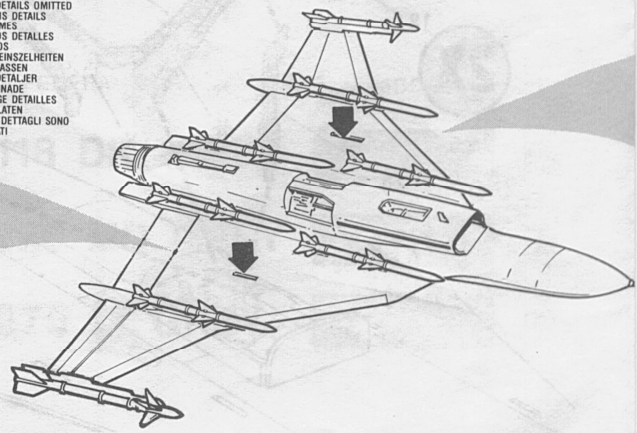



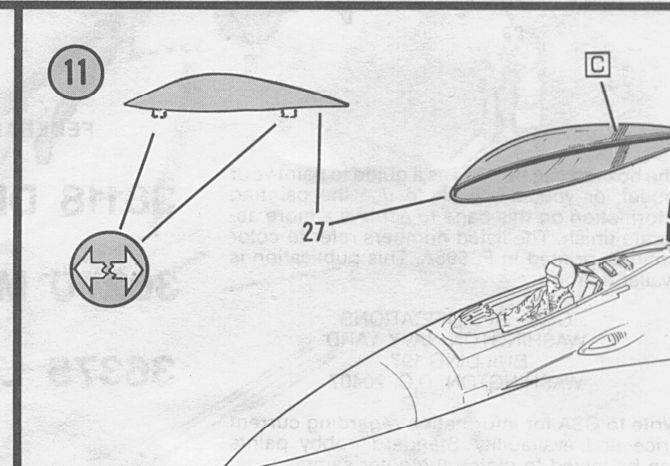
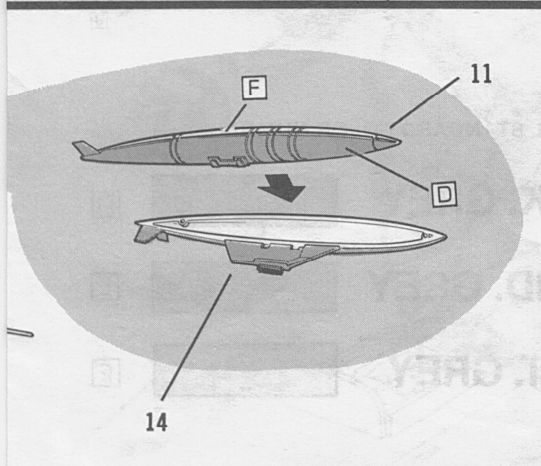
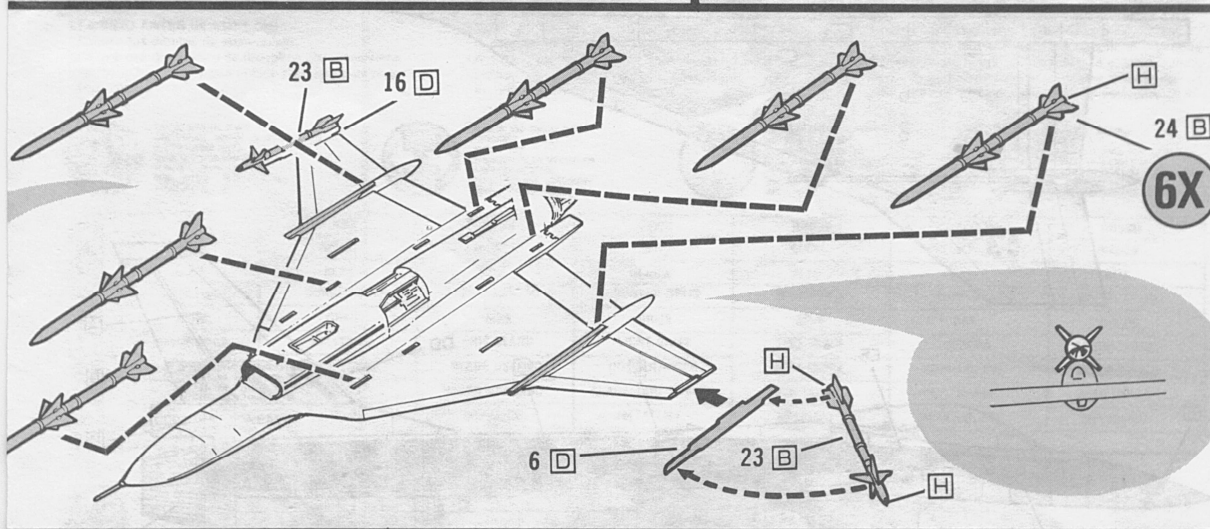
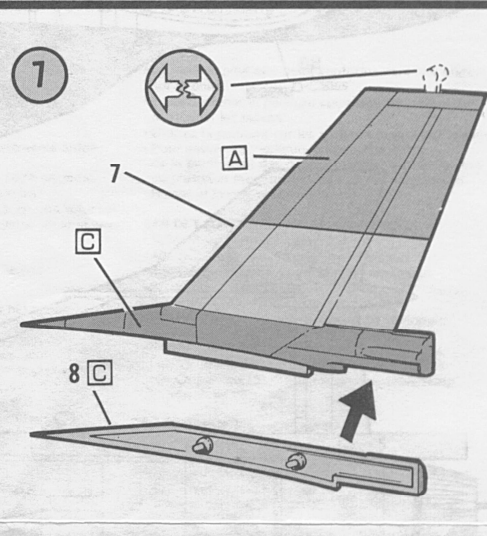
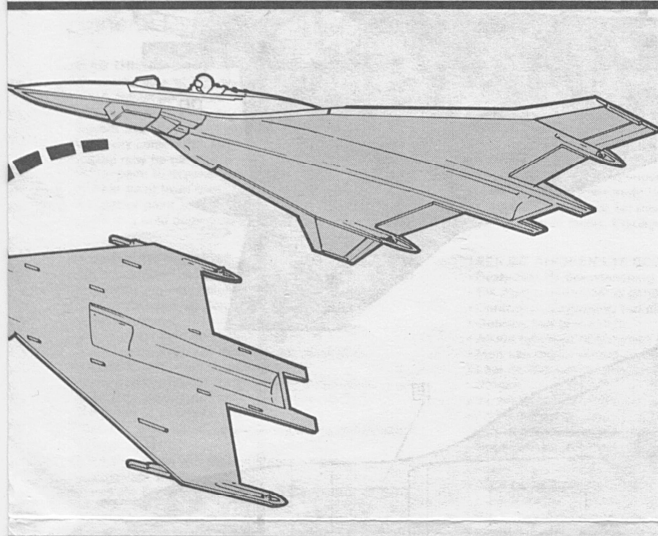
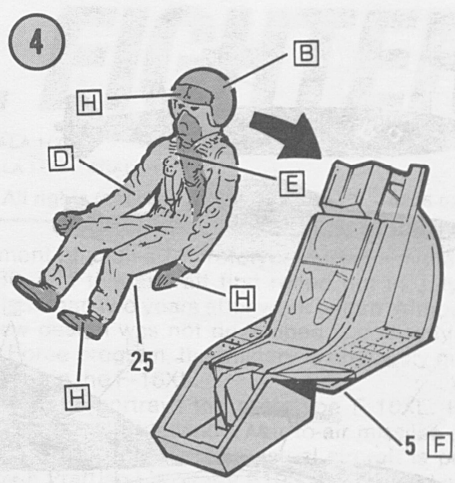
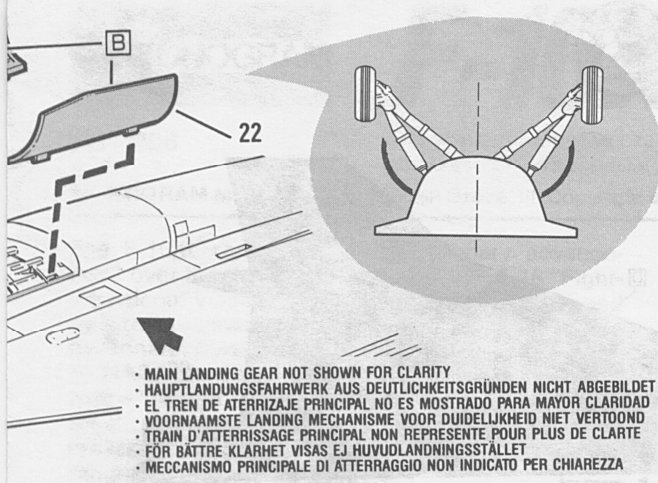

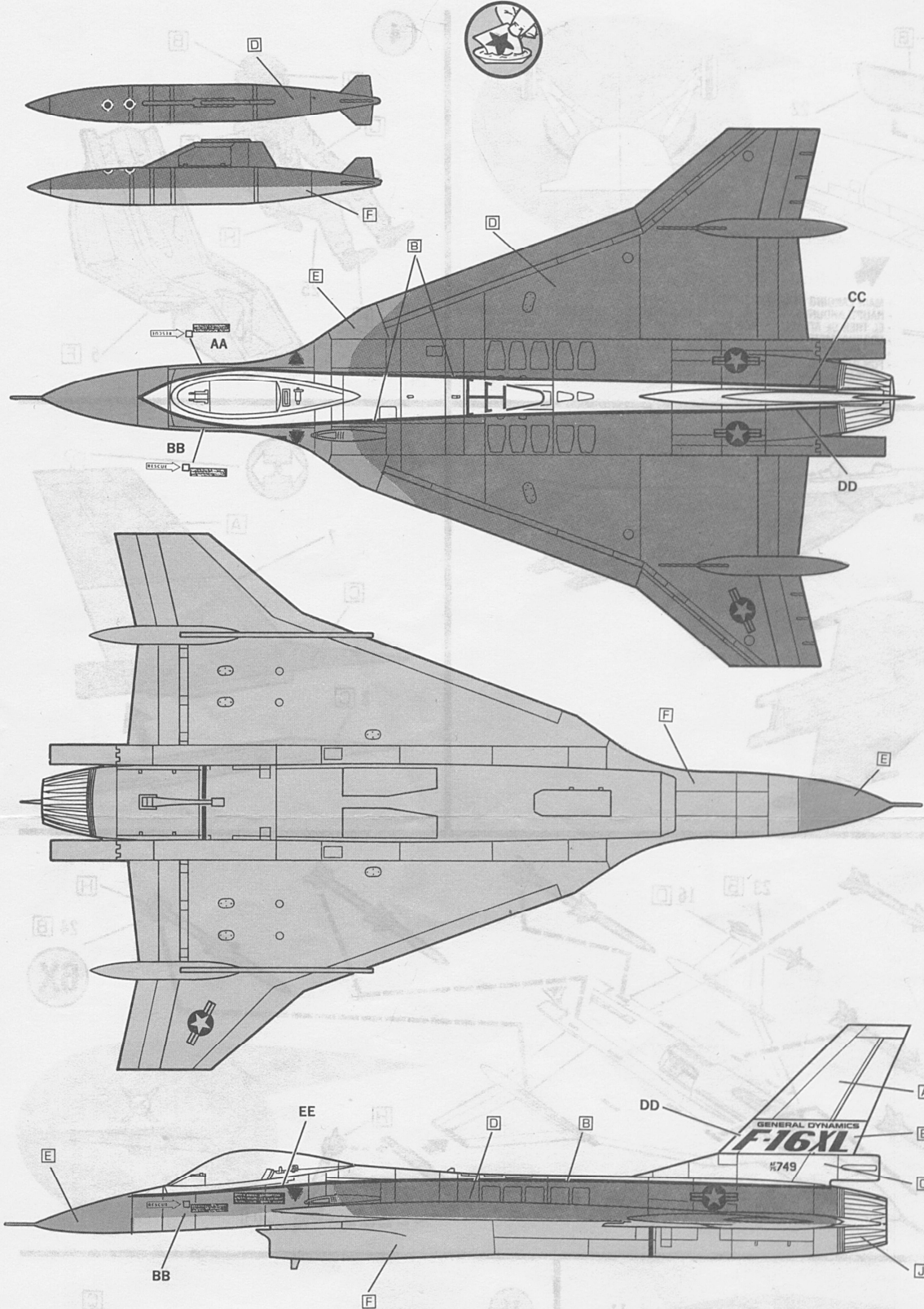

FEDERAL STANDARD COLOR NUMBERS

The box top can be used as a guide to paint your model, or you may wish to use the painting information on this page to achieve a more accurate finish. The listed numbers refer to color samples printed in FS595A. This publication is available from:

GSA - SPECIFICATIONS  
 WASHINGTON NAVY YARD  
 BUILDING 197,  
 WASHINGTON, D.C. 20407

Write to GSA for information regarding current price and availability. Standard hobby paints can be mixed to match the color samples.

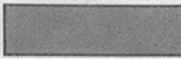
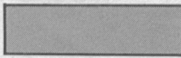
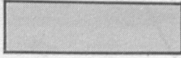
<b>36118 DK. GREY</b>		<b>D</b>
<b>36270 MD. GREY</b>		<b>E</b>
<b>36375 LT. GREY</b>		<b>F</b>