



1/72 SCALE MODEL CONSTRUCTION KIT

# HAWKER HURRICANE Mk I

Together with the Spitfire, the Hawker Hurricane made up the front line equipment of RAF Fighter Command, during the Battle of Britain in 1940. This famous single seat fighter made its first flight in November 1935 and production Mk 1s were delivered to the Royal Air Force in 1937. At the time of the Battle of Britain, 32 RAF squadrons were equipped with Hurricanes. Powerplant, one 1,030 h.p. Rolls-Royce

Merlin II or III engine giving the aircraft a maximum speed of 324 m.p.h. at 18,000ft. Armament, eight .303in machine guns. Wing span 40ft, length 31ft 4in. Markings are provided for the Hurricane Mk 1 flown by Flying Officer A.V. Clowes, D.F.M., of 1 Sqn, based at RAF Wittering, in September/October 1940.

Le Hawker Hurricane constituait, avec le Spitfire, l'équipement de front du Fighter Command de la RAF, en 1940, durant la bataille de Grande-Bretagne. Ce célèbre chasseur monoplace effectua son vol inaugural en novembre 1935 et des Mk 1 de série furent livrés à la Royal Air Force en 1937. A l'époque de la bataille de Grande-Bretagne, 32 escadrilles de la RAF étaient équipées de Hurricanes. Bloc

moteur: un moteur Rolls-Royce Merlin II ou III 1030 CV, donnant à l'appareil une vitesse maximale de 521 km/h à une altitude de 5,486. Armement: huit mitrailleuses de 7,7mm. Envergure: 12,34m; longueur: 9,55m. Les décalcomanies fournies dans ce kit sont celles du Hurricane Mk 1 piloté par Flying Officer A.V. Clowes, D.F.M., de l'Esc. 1, base de la RAF à Wittering, en septembre/octobre 1940.

Zusammen mit der Spitfire bildete die Hawker Hurricane die Frontlinienustrüstung des RAF-Jägerkommandos in der Luftschlacht um England im Jahr 1940. Dieser berühmte einsitzige Jäger führte seinen ersten Flug im November 1935 durch und 1937 wurden dann Serienflugzeuge vom Typ Mk 1 an die Royal Air Force geliefert. Zur Zeit der Luftschlacht um England waren 32 RAF-Staffeln mit Hurricanes ausgerüstet. Das 1030 PS Triebwerk vom Typ Rolls-Royce Merlin II oder

III ermöglichte dem Flugzeug in einer Höhe von 5486m eine Höchstgeschwindigkeit von 521 km/h. Bewaffnung: acht 7,7mm Maschinengewehre. Spannweite 12,34m Länge 9,55m. Die mitgelieferten Kennzeichen sind für die Hurricane Mk 1 gedacht, die von Flying Officer A. V. Clowes, D.F.M., der Staffel 1, RAF Wittering, im September/Oktober 1940 geflogen wurde.

Junto con el Spitfire, el Hawker Hurricane constituyó el equipo de primera línea del Mando de Caza de la RAF durante la Batalla de Inglaterra en 1940. Este famoso caza de un solo asiento realizó su primer vuelo en Noviembre de 1935 y la RAF recibió los primeros Mk 1 de producción en 1937. Durante la Batalla de Inglaterra, 32 escuadrillas de la RAF estaban equipadas con Hurricanes. El equipo de propulsión,

un motor Rolls-Royce Merlin II o III de 1.030CV, proporcionaba al avión una velocidad máxima de 521 km/h a 5.486m. Armamento: ocho ametralladoras de 7,7mm. Envergadura: 12,34m; longitud: 9,55m. Se proveen marcas para el Hurricane Mk 1 que utilizó el Oficial de Vuelo A.V. Clowes, D.F.M., de la Escuadrilla 1, RAF, con base en Wittering, en Septiembre/Octubre de 1940.

Unitamente allo Spitfire, l'apparecchio Hawker Hurricane costituiva la barriera antinamica dei caccia della RAF durante la storica Battaglia d'Inghilterra nell'estate del 1940. Questo famoso caccia monoposto volò per la prima volta nel novembre del 1935: nel 1937, poi, la Royal Air Force ricevette la prima scorta di Mk 1. All'epoca della Battaglia d'Inghilterra, ben 32 Squadroni della RAF erano dotati di apparecchi Hurricane. Il gruppo propulsore era costituito da un motore Rolls-Royce Merlin II

oppure III da 1030 HP che permetteva una velocità massima di 521 km/h a 5.486m. L'armamentario era costituito da 8 mitragliatrici da 0,303 pollici. Apertura alare 12,34m lunghezza 9,55m. La scatola contiene contrassegni per il modello Hurricane Mk 1 pilotato dall'Ufficiale A. V. Clowes, D.F.M. (Medaglia al Merito) del Primo Squadrone con base al Centro RAF di Wittering, nel settembre/ottobre 1940.

### GENERAL INSTRUCTIONS

It is recommended that exploded views are studied and assembly practised before cementing together. Note: small parts are best painted before assembly. Parts should be as drawn and any moulded tabs adhering to parts removed before assembly. All parts are numbered; assemble in sequence.

### INSTRUCTIONS GENERALES

Il est recommandé d'étudier avec soin les dessins et de s'exercer au montage avant de coller les pièces. On peint plus facilement les petites pièces avant de les assembler. Les pièces doivent coïncider avec les dessins et on doit séparer les supports des pièces avant d'assembler celles-ci. Toutes les pièces sont numérotées et doivent être montées en ordre.

### ALLEGEMEINE BAUTIPS

Anordnung und Vollständigkeit aller Bauteile nach Anleitung, Abbildungen und Deckbild überprüfen. Vor Bemalung und Montage Gussgrate entfernen und Teilpassung ungeleimt probieren. Nur nächstbenötigte Teile von Gussrippen lösen bzw Sichtbeuteln entnehmen. Baufolge entspricht der Teilnummerierung. Einbauteile vorab bemalen.

### INSTRUCCIONES GENERALES

Se recomienda estudiar cuidadosamente los dibujos y practicar el montaje antes de pegar las piezas. Nota: Las partes pequeñas se pintan mejor antes de montarlas. Las piezas deben coincidir con los dibujos y deben quitarse las lengüetas moldeadas adheridas a las piezas antes de montarlas. Todas las partes están numeradas y deben montarse por orden de sucesión.

### ISTRUZIONI GENERALI

Si raccomanda di studiare accuratamente i disegni e di esercitarsi al montaggio prima di incollare i pezzi. Si dipingono più facilmente i piccoli pezzi prima di montarli. I pezzi devono coincidere con i disegni e si deve separare i supporti dei pezzi prima del montaggio. Tutti i pezzi sono numerati e devono essere montati in sequenza.

 CEMENT COLLE KLEBEN PEGAMENTO COLLA	 DO NOT CEMENT NE PAS COLLER NICHT KLEBEN NO PEGAR NON INCOLLARE	 ALTERNATIVE PARTS PIECES ALTERNATIVES WECHSELBAUTEILE PARTES ALTERNATIVAS PEZZI ALTERNATIVI	 TRANSPARENCY TRANSPARENT KLARSICHTTEIL TRANSPARENCIA TRANSPARENZA	 ASSEMBLED SECTION ASSEMBLAGE BAUABSCHNITT SECCION MONTADA MONTAGGIO
---	---	---	---	---

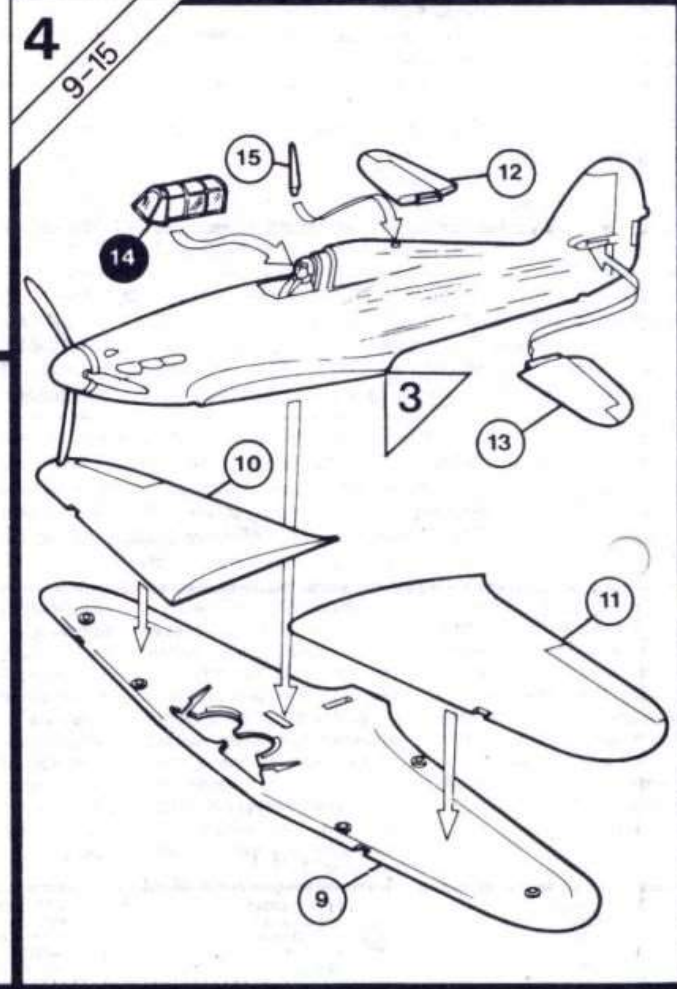
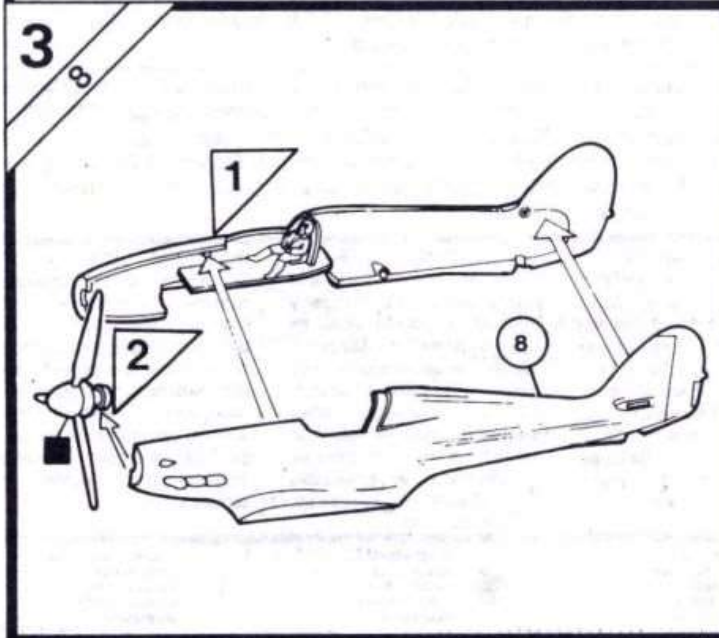
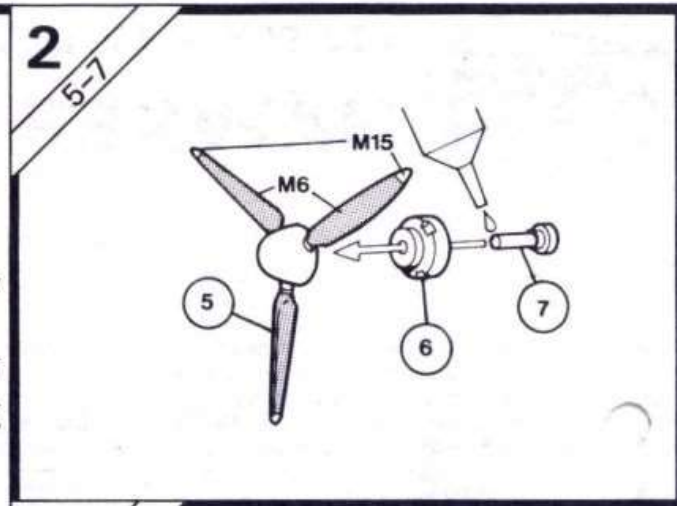
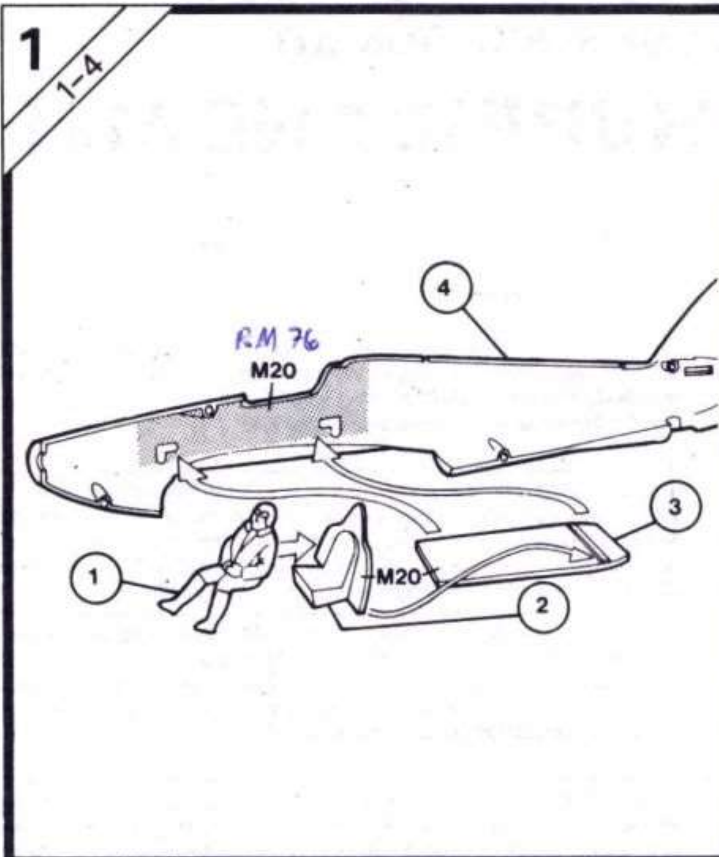

5

16-19

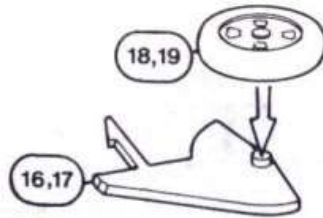

6

18-23

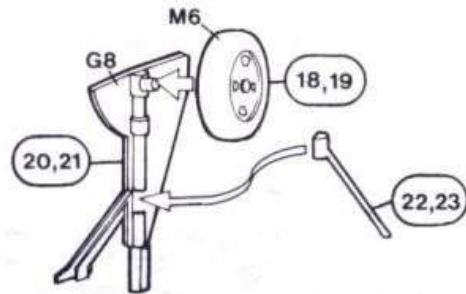

7

24-28

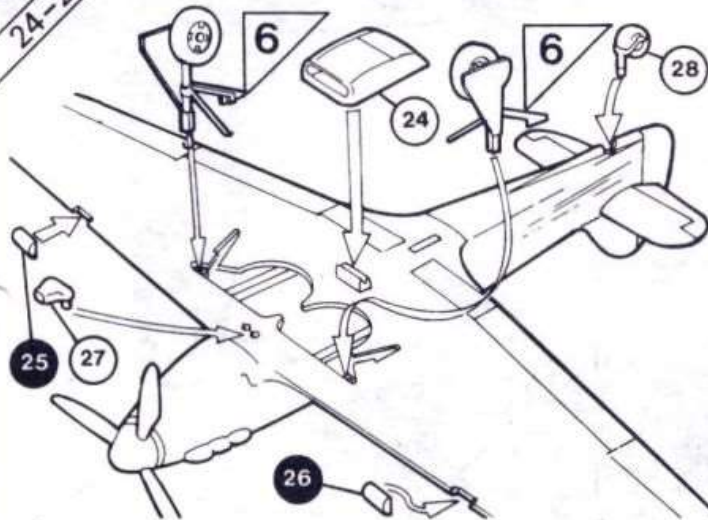

LOWERED UNDERCARRIAGE  
 TRAIN D'ATERRISSAGE  
 AUSGEFAHRENES FAHRWERK  
 TREN DE ATERRIZAJE ABATIDO  
 CARRELLO ABBASSATO

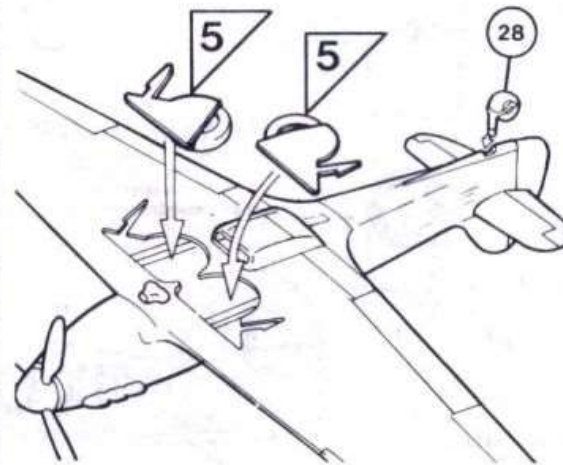

UNDERCARRIAGE RETRACTED  
 TRAIN D'ATERRISSAGE RENTRÉ  
 FAHRWERK EINGEZOGEN  
 TREN DE ATERRIZAJE RETRACTADO  
 CARRELLO RETRATTO

M3 OLIVE GREEN  
VERT OLIVE  
OLIVGRÜN  
VERDE OLIVA  
VERDE OLIVA

M5 LIGHT BROWN  
BRUN CLAIR  
HELL BRAUN  
MARRÓN CLARO  
MARRONE CHIARO

M8 DUCK EGG BLUE  
BLEU DEUF DE CANARD  
ENTENEIBLAU  
AZUL HUEVO DE PATO  
BLU UOVO D'ANITRA

USE IN CONJUNCTION WITH BOX ARTWORK  
UTILISER EN SUIVANT L'ILLUSTRATION SUR LA BOITE  
IN VERBINDUNG MIT DEM DECKELBILD BEACHTEN  
USAR DE ACUARDO CON LA ILUSTRACION DE LA CAJA  
UTILIZZARE SECONDO L'ILLUSTRAZIONE SULLA SCATOLA

PAINT NOS. M1 M3 M5 M6 M8 M15

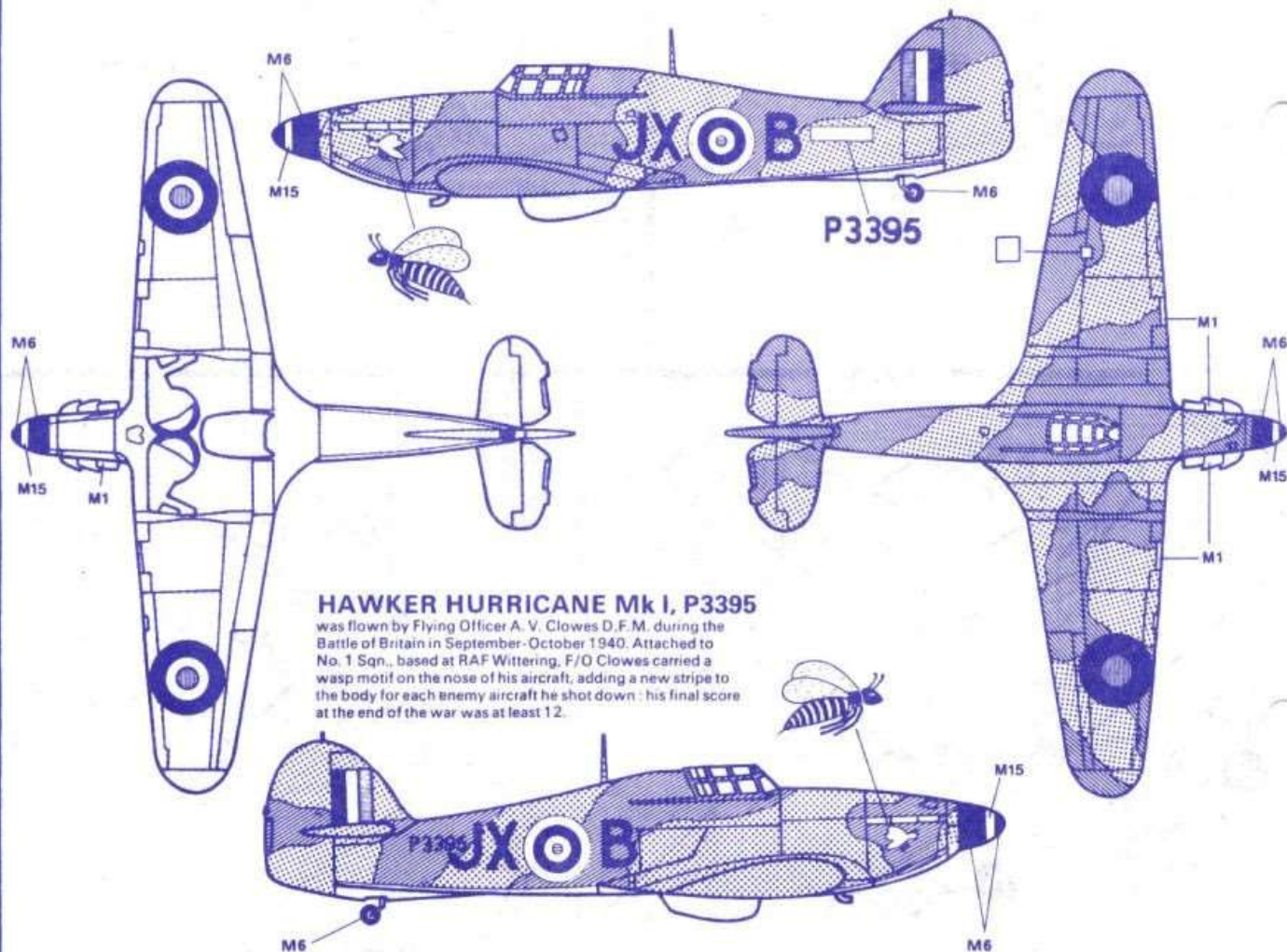

### HAWKER HURRICANE Mk I, P3395

was flown by Flying Officer A. V. Clowes D.F.M. during the Battle of Britain in September-October 1940. Attached to No. 1 Sqn., based at RAF Wittering, F/O Clowes carried a wasp motif on the nose of his aircraft, adding a new stripe to the body for each enemy aircraft he shot down: his final score at the end of the war was at least 12.

Apply transfers, separate into required subjects dip in warm water for a few seconds, slide off backing into position shown in illustration.

Appliquer les décalcomanies, découper les sujets voulus, les tremper dans de l'eau tiède pendant quelques secondes, mettre en place et décoller le dos comme le montre l'illustration.

Dekals aufzukleben, aussortieren, einige Sekunden lang in warmes Wasser tauchen und dann von der Unterlage herunter in die gewünschte Position schieben (siehe Abbildung).

Para aplicar las calcomanías, separar los temas deseados, sumergir en agua tibia durante unos segundos y colocar en posición, despegando el dorso como muestra la ilustración.

Applicate le decalcomanie, ritagliate i soggetti richiesti, immergeteli in acqua tiepida per alcuni secondi, metteteli in posizione staccando il rinforzo come indicato nell'illustrazione.